

350 Realm

Owner's Manual



THE UNSINKABLE LEGEND

350 *Realm*

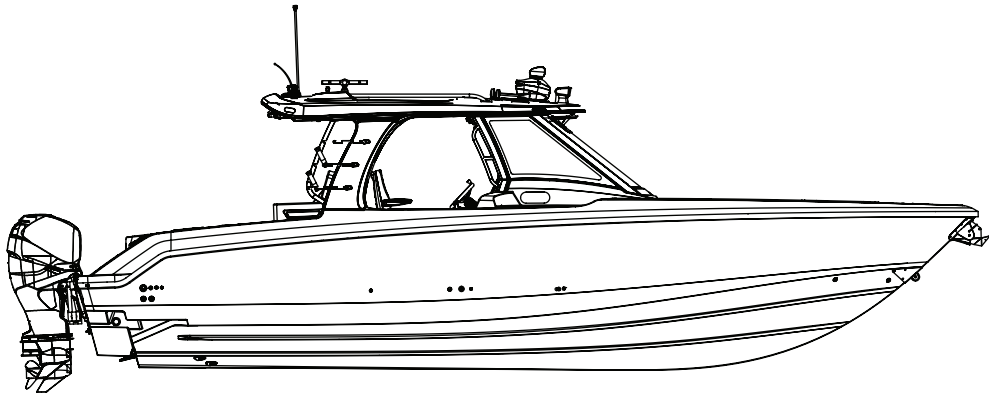

The mission of Boston Whaler® is to provide consumers with the safest, highest quality, most durable boats in the world.

 **WARNING**

Operating, servicing and maintaining a recreational marine vessel can expose you to chemicals including engine exhaust, carbon monoxide, phthalates, and lead, which are known to the State of California to cause cancer and birth defects or other reproductive harm. To minimize exposure, avoid breathing exhaust, service your vessel in a well-ventilated area and wear gloves or wash your hands frequently when servicing this vessel. For more information go to www.P65warnings.ca.gov/marine.



T H E U N S I N K A B L E L E G E N D™

Welcome to the Boston Whaler® family and congratulations on your purchase!

For over 60 years, Boston Whaler has engineered the most reliable and forward-thinking boats on the water. Every chapter of our history starts with a belief in pushing the limits of what's possible, and this heritage is cause for both reflection and celebration.

Standing behind every Whaler is an extremely qualified network of dealers to provide you with a truly exceptional boating experience. Information and assistance is also available at bostonwhaler.com, where you will find customer resources including how-to videos, maintenance tips, and other technical content. While there, don't forget to sign up to receive future issues of Boston Whaler's lifestyle magazine, Whaler.

Since Boston Whaler's inception in 1958, we are committed to providing customers with the safest, highest-quality, most durable boats in the world. We are confident that as a Whaler owner you will love the quality and pride that is built into every boat.

From all of us here at Whaler, thank you for selecting one of our a legendary and innovative boats. May that choice bring you a lifetime of boating enjoyment.

History

Since our founding more than 60 years ago, Boston Whaler® has conceived and built peerless designs that meet boaters' diverse and changing needs. It all began in Braintree, Massachusetts with founder Richard Fisher's inspired new construction method featuring two significant innovations: first, a twin-sponson hull design that resulted in superior stability and a remarkably dry ride, and second, a unique foam-core construction that made the boat not only durable, but unsinkable as well. So for people whose livelihood and lives depend on their boat, Boston Whaler is the right choice because of our seaworthiness, dependability, and the inherent safety of a hull that won't sink even if severely damaged. Plain and simple, Boston Whaler boats are built to last.

In 1961, Fisher's demonstration of that unsinkability was captured by *Life* magazine in photos showing a Whaler® boat being sawed in half and Fisher then motoring away in the remaining half. True to Fisher's vision, Boston Whaler's world-class team has consistently pushed the envelope, furthering advances in manufacturing, design, navigation, and propulsion technologies.

On September 26, 1996, Richard Fisher was posthumously inducted into the National Marine Manufacturer's Association (NMMA) hall of fame for accomplishments made in marine engineering and construction.



In 1958, the legend is born as company founder Dick Fisher demonstrates a Boston Whaler's total unsinkability.

TABLE of CONTENTS

Passenger Areas.....	2-5	Docking	2-36
Recommended Passenger Locations	2-6	Lifting.....	2-36
Location Of Thru-Hull Fittings.....	2-7	Yacht Tender Package (Option)	2-37
General Layout, Exterior	2-9	Out of Water Storage.....	2-38
General Layout, Bow Side Pockets	2-10		
General Layout, Control Station.....	2-11		
General Layout, Bilge.....	2-12	Section 3 • Systems & Operation	
General Layout, Forward Bilge.....	2-13	Bilge Pumps.....	3-1
General Layout, Port Aft Cockpit.....	2-14	Access To The Pumps	3-2
General Layout, Starboard Aft Cockpit.....	2-15	Bilge Pump Maintenance	3-2
General Layout, Prep Station.....	2-16	Float Switch	3-2
General Layout, Hardtop	2-17	Emergency High Water Bilge Pump.....	3-2
General Layout, Cabin Interior, Port	2-18	Fuel & Oil Spillage	3-2
General Layout, Cabin Interior, Starboard	2-19	Gray Water Sump.....	3-3
General Layout, Cabin Interior, Head	2-20	Maintenance	3-3
General Layout, Control Station Seating ..	2-21	Fuel System.....	3-4
Seating.....	2-22	Fuel Tank	3-4
Notable Options	2-23	Fuel Vent	3-5
Helm Switch Panels	2-24	Fuel Distribution System.....	3-5
Joystick Piloting (Option)	2-25	Filling the Tank	3-5
Gear Shift & Throttle Control.....	2-26	Static Electricity and the Fuel System.....	3-6
Digital Throttle/Shift (DTS®).....	2-26	Ethanol-Blended Fuel.....	3-7
DTS Control Pad	2-26	Maintaining a Full Tank	3-7
Dock.....	2-26	Phase Separation.....	3-7
Throttle Only	2-26	Additives.....	3-7
1 Lever	2-27	Fuel Filters	3-7
Shadow Mode Technology	2-27	Fuel/Water Separator.....	3-7
Auto Sync®	2-27	Maintenance	3-7
Transfer	2-27	Storage.....	3-7
Power trim Operation	2-27	Power Steering.....	3-9
Power Trim and Trim Tabs.....	2-28	Filling & Maintenance.....	3-9
Trim Guidelines.....	2-28	Starting/Stopping the Engines.....	3-10
Active Trim (Option)	2-28	Starting The Engines.....	3-10
Theft Deterrent System (TDS)		Parallel Switching.....	3-11
/Whaler Watch	2-28	Warming Up Engines.....	3-11
VesselView.....	2-29	Stopping Engines.....	3-12
System Calibration		Theft deterrent System (TDS)/Whaler Watch .	
(For First Time Use).....	2-29	with Remote Connectivity (Option).....	3-12
VesselView Mobile	2-29	Starting the Engines w/TDS	
Navigation Lighting.....	2-30	Whaler Watch	3-12
Operating The navigation Lighting	2-30	Fresh Water System	3-13
Canvas (Option).....	2-31	Filling the tank.....	3-13
Installation.....	2-31	Freshwater Pump.....	3-14
To Remove Canvas	2-32	Deck Showers.....	3-14
Bow Thruster	2-33	Anchor Locker Washdown	3-15
To Operate Bow Thruster	2-34	Water Heater	3-15
Towing, Docking and Lifting	2-35	Tempering Valve.....	3-15
Bow Tow Eye (Option)	2-35		

TABLE of CONTENTS

Maintenance	3-16	Stowable Cockpit Table (Option).....	3-36
Fresh Water System Maintenance	3-16	To Set Up Tables.....	3-36
Raw Water System	3-17	Prep Station Table	3-36
Full-Fill Livewell	3-17	Electric Grill (Option)	3-37
Full-Fill Livewell Operation.....	3-18	To Access the grill.....	3-37
Raw Water Washdown.....	3-18	To Close the Cover.....	3-37
Maintenance	3-18	Automatic Shut-Off	3-37
Head System	3-19	Removable grease Pan	3-37
Environmental Considerations.....	3-19	Radial Outriggers (Option)	3-38
VacuFlush Head.....	3-19	Operation.....	3-38
Operation.....	3-19	Maintenance	3-38
Macerator & Dockside Discharge.....	3-20	Radial Outriggers (Option)	3-39
Overboard Discharge	3-20	Operation.....	3-39
Dockside Pump-Out	3-21	Maintenance	3-39
Waste System Vent.....	3-22	Fold Down Visibility Platform	3-40
Replacing Old Vent Filter	3-22	Spotlight (Option)	3-40
Air Conditioning	3-22	Bow Table (Option)	3-40
Operation.....	3-22	Thermal Night Vision (Option).....	3-40
Starting The System	3-22	Cabin Convertible Couch	3-41
Automatic Engine Flushing		Electric Windshield Vent.....	3-41
System (Option)	3-24	Windshield Wiper/Washer	3-41
Operation.....	3-24	Electric Sunshade (Option).....	3-41
Generator (Option).....	3-25	Collapsible Swim Ladder	3-42
Starting The Generator	3-26	Upper Control Station (Option).....	3-43
Stopping The Generator	3-26	Station Transfer	3-43
Maintenance	3-26	Entertainment System	3-44
Operation in European Union Member		Stereo	3-44
Countries	3-27	Operating Your Stereo Using	
Raw Water Strainer Maintenance	3-27	a USB Device.....	3-45
Shore Power (Option).....	3-28	Courtesy Lighting	3-45
ELCI (Equipment Leakage Circuit		Cabin Lights	3-45
Interrupter).....	3-28	Television.....	3-45
Shore Power Operation	3-29	iPad with Charging Station	3-46
Single Cord Shore Power	3-30	Hardtop Lighting	3-47
Battery Charging	3-31	Blue Aesthetic Lighting.....	3-47
Shore Power Load Management.....	3-31	Map Light.....	3-47
Isolation Transformer	3-31	Flood Lights	3-47
Fire Suppression System (Option).....	3-31	Underwater Lights (Option).....	3-48
In The Event Of Discharge	3-32	Machinery Space Lighting	3-48
Manual Override System	3-32	Adjustable helm Seat.....	3-48
To Operate	3-32	Trim Tabs.....	3-48
Dive Door	3-33	Operation.....	3-49
Dive Ladder	3-33	Electrolytic Corrosion & Zinc Anodes	3-49
Fishbox With Pump Out Discharge.....	3-34	Maintenance	3-49
Port Fishbox Freezer Plates (Option)	3-34	Auto Glide Boat Control System.....	3-49
Prep Station Freezer Coils (Option)	3-34	Gyroscopic Stabilizer (Option)	3-50
Electric Downrigger Receptacles (Option)	3-35	Propeller.....	3-51
Foldaway Aft bench Seat.....	3-36	Trimming The Engines	3-51

TABLE of CONTENTS

Changing Propellers	3-51
Anchor Windlass	3-52
Operation.....	3-53
Operating From The Helm	3-53
Operating From The Bow	3-53
Operating The Windlass Manually	3-54
Anchoring	3-54
Considerations.....	3-54
Lowering the Anchor	3-55
Setting the Anchor	3-55
Weighing the Anchor	3-55

Section 4 • Electrical

Electrical System	4-1
DC Electrical System	4-1
Batteries.....	4-1
Battery Trays.....	4-1
Standard Battery Locations.....	4-1
Gyroscopic Stabilizer Batteries (Option) .	4-2
Battery Charger.....	4-2
Overload Protection	4-3
Maintenance	4-3
Battery Switches.....	4-3
Remote Battery Switches	4-3
Automatic Charging Relays (ACR)	4-3
Manual Control Override.....	4-3
House Battery Trays	4-5
Battery Maintenance.....	4-5
12 Volt Accessory receptacles.....	4-5
120 Volt Receptacles	4-6
Theft Deterrent System (TDS)/Whaler Watch w/ remote connectivity	4-6
Main DC Breaker Panel	4-7
DC Distribution Panel.....	4-8
Main AC Breaker Panel.....	4-10
AC Electrical System	4-11
Component Breakers	4-11
Fuse Blocks.....	4-11
Ground Fault Interrupter Receptacle (GFI) ..	4-12
Digital Switching	4-13
iPad	4-14
C-Zone WiFi Interface Module	4-15
Transducer.....	4-17
Electrical Schematics & Harnesses	4-18
Wiring Identification Chart	4-18

Section 5 • Care & Maintenance

Routine Care & Maintenance	5-1
Hull	5-1
Waxing the Gel Coat Surfaces	5-1
Hull Maintenance.....	5-2
Hull Blistering	5-2
Prevention	5-2
Bottom Painting	5-2
Zinc Anodes	5-3
Bottom Painting a Bare Hull.....	5-3
Bottom Painting a Pre-Painted Hull.....	5-3
Rubrail care	5-4
Cleaning Fiberglass & Non-Skid	5-4
Stainless Steel Care.....	5-4
Teak Maintenance	5-5
Seats (Mechanical Parts).....	5-5
Aluminum Care	5-5
Cushions.....	5-6
To Clean Your Cushions.....	5-6
Cleaning Your Instrument Gauges	5-6
Powder Coated Surfaces	5-6
Powder Coating Touch-Up	5-7
Touch-Up Procedure	5-7
Canvas Care and Maintenance.....	5-7
Maintaining a Good Appearance.....	5-8
On a Regular Basis.....	5-8
Cleaning stubborn Stains.....	5-8
Maintaining Zippers and Hardware.....	5-8
Maintaining Your Vinyl Windows	5-8
Storing Clear Vinyl.....	5-9
Cleaning Tempered Glass Windshield	5-9
Solid Surface Countertops.....	5-9
Routine Care	5-9
Minor Cuts And Scratches.....	5-9
Heat Damage	5-9
Other Damage.....	5-10
Refurbishing	5-10
Long term Storage & Winterization	5-10
Engine	5-10
Fuel System	5-10
Battery	5-11
Mixing Fresh/New and Used/Dead Batteries..	5-11
Mixing Battery Types.....	5-11
Mixing Battery Brands	5-11
Livewell/Raw Water System.....	5-11
Fresh Water System.....	5-11
After Long term Storage	5-12

TABLE of CONTENTS

Head System.....	5-12	Maintenance Log.....	5-15
Air handling System.....	5-12		
Sump.....	5-12	Attachments	
Electrical System	5-12	Commissioning Checklist	
Deck.....	5-12		
Drainage.....	5-12		
Avoid Loss	5-12		
Cover.....	5-13		
Environment	5-13		
Reinforcement Locations.....	5-13		
Reinforcement Location Diagram	5-14		

Preface

READ AND RETAIN this manual. If the boat is sold, ensure all documentation is transferred to the new owner.

Information in this publication is based on the latest product specifications available at the time of printing. Boston Whaler reserves the right to make changes at any time without prior notice. Boston Whaler is not responsible for specification changes to parts or accessories manufactured by other companies.

NOTE: Equipment may vary depending on options selected.

If needed in connection with selling your boat, service history or warranty records on vessels should be requested from the original selling dealer, the servicing dealer and/or the previous owner (where applicable). Information regarding open safety recalls is maintained by the United States Coast Guard, and can be obtained by visiting uscgboating.org.

Brunswick Corporation registered trademarks: Mercury Marine, Mercury Racing, Optimax, Nautic-On, Skyhook, SmartCraft, Verado, Vantage, VesselView, VesselView Mobile.

Boston Whaler, Inc. registered trademarks: Boston Whaler, Boston Whaler with harpoon and hull logo, Conquest, Dauntless, Montauk, Outrage, Realm, Unibond, Whaler.

All other trademarks listed in this publication are the property of their respective owners.

BOSTON WHALER® • A BRUNSWICK COMPANY

© NOVEMBER 2020 Brunswick Corporation



BOSTON WHALER LIMITED MANUFACTURER WARRANTY (US AND CANADA)

Boston Whaler, Inc. (“Boston Whaler”) provides the following Limited Manufacturer Warranty to the original retail owner of its 2023 model year Boats, if purchased from an authorized Boston Whaler Dealer and operated under normal, non-commercial use, subject to the remedies, exclusions, and limitations set out below.

1. **Ten-Year Structural Hull Limited Warranty:** Any Structural Hull Defect in material or workmanship which is reported within ten (10) years from the date of sale to the original retail owner will be repaired or replaced at Boston Whaler’s sole discretion. The “Hull” shall mean the single fiberglass molded shell and integral structural components. A Structural Hull Defect shall mean a substantial defect in the Boat’s Hull which causes the Boat to be unfit or unsafe for general use as a pleasure craft under normal operating conditions.

2. **Three-Year Limited Warranty on Components Manufactured or Installed By Boston Whaler:** (not applicable to 13 Super Sport or 16 Super Sport models): Boston Whaler will repair or replace, at its sole discretion, any components manufactured or installed by Boston Whaler that are defective in factory materials and/or workmanship, which are reported within three (3) years from the date of sale to the original retail owner, and are not addressed in the specific warranties listed in paragraphs 1 or 4 or set out in the Exclusions paragraph below.

3. **One-Year Limited Warranty on Accessory Components for the 13 Super Sport and 16 Super Sport Models:** Boston Whaler provides the following Limited Warranty to the original retail owner of any factory-authorized accessory for the 2023 model year 13 Super Sport and 16 Super Sport, if purchased from an authorized Boston Whaler Dealer, authorized Boston Whaler website or any Boston Whaler affiliate and utilized under normal, non-commercial use (“Accessory”), subject to the remedies, exclusions, and limitations set out below. Boston Whaler will repair or replace, at its sole discretion, any Accessory that is defective in material or workmanship, which is reported within one (1) year from the date of sale to the original retail owner. Boston Whaler is not responsible for any defect and/or damage to the Accessory and/or the Boat caused by improper installation, whether performed by the retail owner, dealer or any other third party.

4. **One-Year Limited Warranty on Upholstered Items, Canvas, Teak, and Powder Coating:** Boston Whaler will repair or replace, at its sole discretion, any upholstered items, canvas, teak, and powder coating manufactured or installed by Boston Whaler that are defective in factory materials and/or workmanship and are reported within one (1) year from the date of sale to the original retail owner.

5. **Limited Engine Warranty:** Retail owners will be entitled to the limited engine warranty as provided in the warranty manual from the engine manufacturer that was delivered to the retail owner with his or her Boston Whaler Boat.

EXCLUSIONS

This Limited Manufacturer Warranty does not apply to any Boat which has been salvaged or declared a total loss or constructive total loss for any reason not covered in this limited warranty. This Warranty also does not apply to the following items:

- 1) Expenses for hauling out or transportation to and from the dealer or the Boston Whaler factory for warranty service.
- 2) Equipment or accessories which are not installed by Boston Whaler or which carry their own individual warranties, including but not limited to engines, engine components, batteries, propellers, controls, steering mechanisms, and electronics.
- 3) Damage, deterioration, discoloration or mold of cushions or cosmetic surface finishes, including scratches,

gouges, chips, chalking, blistering, cracking, crazing, fading or oxidation of gel coat, stress lines, plated or painted metal and stainless steel finishes, plastics or acrylic materials, or anti-fouling bottom paint.

- 4) Windshield breakage and leakage.
- 5) Damage resulting from abuse, misuse, improper rigging and installation by an owner or any other person or entity that is not an authorized dealer, accidents, or overloading or powering in excess of the recommended maximum horsepower.
- 7) Failure of the owner to use, maintain, or store the Boat as specified in the Boston Whaler owner's manual; and any other failure to provide reasonable care and maintenance. Normal wear and tear maintenance items are excluded from warranty coverage including but not limited to filters, bulbs, batteries, bungees, wiper blades, anchor rope, trailer finishes, tires, brakes, bearings, and lights.
- 8) Any Boston Whaler Boat which has been altered or modified from Boston Whaler factory specifications, including penetration of the hull by anyone other than Boston Whaler factory personnel or Boston Whaler authorized dealer service personnel following factory specified procedures.
- 9) Damages resulting from use of improper trailer, improperly placed supporting bunks or slings, incorrect bunks placement, or improper boat lift or sling.
- 10) Damages due to failure to properly tow the Boat. For those Boats for which Boston Whaler offers a yacht tender package, damages due to towing when the package has not been installed.
- 11) Any Boston Whaler Boat used for commercial purposes, which includes, but is not limited to, any for-profit or other revenue-generating uses.
- 12) Any representation or implication relating to speed, range, fuel consumption or estimated performance characteristics.
- 13) Any failure or defect caused by an act of nature resulting in damage, cost, or expense.
- 14) Any failure or defect arising from a previous repair made by a non-authorized service provider.
- 15) Any item exceeding the expressed coverage limits specified in any Boston Whaler Limited Manufacturer Warranty.
- 16) Failure of the owner to use, maintain, or store an Accessory in reasonable fashion; and any other failure to provide reasonable care and maintenance.
- 17) Any accessory which has been altered or modified from Boston Whaler factory specifications.
- 18) Any accessory not purchased from an authorized Boston Whaler Dealer, authorized Boston Whaler website, or authorized Boston Whaler affiliate. For a list of Boston Whaler's affiliates, please refer to www.brunswick.com.
- 19) Any accessory used for commercial purposes, which includes but is not limited to, any for-profit or other revenue generating uses.
- 20) Any defect or repair requiring redesign of the Boat, except pursuant to the recall provisions of the United States Federal Boat Safety Act of 1971 or the recall laws of any other foreign jurisdiction.

SOLE REMEDY

THE REMEDY OF REPAIR OR REPLACEMENT OF PARTS OR MATERIALS THAT ARE FOUND TO BE DEFECTIVE IN FACTORY MATERIALS OR WORKMANSHIP COVERED BY THIS LIMITED MANUFACTURER WARRANTY SHALL CONSTITUTE THE OWNER'S SOLE AND EXCLUSIVE REMEDY AGAINST BOSTON WHALER FOR ANY CLAIMS WHATSOEVER OF ECONOMIC LOSS RESULTING FROM PRODUCT FAILURE.

ENVIRONMENTAL POLICIES

In keeping with environmental policies and practices, Boston Whaler reserves the right to utilize reconditioned, refurbished, repaired or remanufactured products or parts in the warranty repair or replacement process. Such products and parts will be comparable in function and performance to an original product or part and warranted for the remainder of the original warranty period. In no event shall any repair or replacement under this Limited Manufacturer Warranty exceed the fair market value of the product as of the date of the owner's claim. Acceptance of any product returned or any refund provided by Boston Whaler shall not be deemed an admission that the product is defective. Products that are replaced become the property of Boston Whaler.

OTHER LIMITATIONS

EXCEPT AS SET FORTH HEREIN, THERE ARE NO OTHER WARRANTIES, EITHER EXPRESS OR IMPLIED, PROVIDED BY BOSTON WHALER ON THIS BOAT. ALL OTHER WARRANTIES, EXPRESS OR IMPLIED, INCLUDING IMPLIED WARRANTIES OF FITNESS AND MERCHANTABILITY, ARE EXPRESSLY EXCLUDED. BOSTON WHALER FURTHER DISCLAIMS ANY LIABILITY FOR ECONOMIC LOSS ARISING FROM CLAIMS OF PRODUCT FAILURE, NEGLIGENCE, DEFECTIVE DESIGN, MANUFACTURING DEFECT, FAILURE TO WARN AND/OR INSTRUCT, LACK OF SEAWORTHINESS, AND ANY OTHER THEORY OF LIABILITY NOT EXPRESSLY COVERED UNDER THE TERMS OF THIS LIMITED MANUFACTURER WARRANTY.

ANY IMPLIED WARRANTY OF MERCHANTABILITY OR FITNESS FOR A PARTICULAR PURPOSE IS DISCLAIMED. TO THE EXTENT THE IMPLIED WARRANTY CANNOT BE DISCLAIMED, IT IS LIMITED TO THE SHORTER OF ONE YEAR FROM THE DATE OF DELIVERY TO THE FIRST RETAIL OWNER OR THE DURATION OF THE RESPECTIVE EXPRESS LIMITED WARRANTIES STATED HEREIN. TO THE EXTENT ALLOWED BY LAW, NEITHER BOSTON WHALER, NOR THE SELLING DEALER, SHALL HAVE ANY RESPONSIBILITY FOR LOSS OF THE BOAT, LOSS OF TIME, INCONVENIENCE, COMMERCIAL LOSS OR CONSEQUENTIAL DAMAGES. SOME STATES DO NOT ALLOW LIMITATIONS ON HOW LONG AN IMPLIED WARRANTY LASTS, SO THE ABOVE LIMITATION MAY NOT BE APPLICABLE. SOME STATES DO NOT ALLOW THE EXCLUSION OR LIMITATION OF INCIDENTAL OR CONSEQUENTIAL DAMAGES, SO THE ABOVE LIMITATIONS OR EXCLUSIONS MAY NOT BE APPLICABLE. THIS WARRANTY GIVES THE OWNER SPECIFIC LEGAL RIGHTS, AND THE OWNER MAY ALSO HAVE OTHER RIGHTS WHICH VARY FROM STATE TO STATE OR COUNTRY TO COUNTRY.

STATUTE OF LIMITATIONS

Any action for rescission or revocation against Boston Whaler shall be barred unless it is commenced within one (1) year from the date of accrual of such cause of action. This provision does not grant any consumer a right of rescission or revocation against Boston Whaler, where such right does not otherwise exist under applicable law. Some states may not allow the applicable statute of limitations for rescission or revocation to be reduced, so this provision may not apply to each retail owner.

OWNER'S OBLIGATIONS

To initiate a warranty claim, it is the responsibility of the owner to contact an authorized Boston Whaler dealer immediately after discovery of any defect, describe the nature of the problem, and provide a hull serial number, date of purchase, and name of selling dealer. The authorized dealer will notify Boston Whaler, who is solely responsible for determining and authorizing in writing the remedial action(s) to be performed at either an authorized Boston Whaler dealership chosen by Boston Whaler or at the Boston Whaler factory. The owner should notify Boston Whaler of any Boat being repaired by an authorized Boston Whaler dealer which has been at the dealership for fifteen (15) days, or of any claimed defect which was not corrected

after one repair attempt. The owner must provide Boston Whaler with a reasonable opportunity to repair, and reasonable access to the Boston Whaler Boat for warranty service and the owner shall pay for all related transportation charges and/or travel time. If the owner cannot deliver the product to such a dealer, written notice must be given to Boston Whaler. Boston Whaler will then arrange for the inspection and any covered repair and the owner shall pay for all related transportation charges and/or travel time. Our privacy policies are available at www.bostonwhaler.com.

ASSIGNMENT OF COMPONENT WARRANTIES

Except as expressly set out herein, all warranties provided by the manufacturers and distributors of components, equipment, and parts on the Boat (collectively “Component Manufacturers”) are hereby assigned to the owner to the extent permitted by the Component Manufacturers, as the owner’s sole and exclusive remedy with respect to such items.

REGISTRATION & WARRANTY TRANSFER POLICY

The limited warranty coverage is activated by the authorized selling dealer registering the sale of a new Boat with Boston Whaler.

The Ten-Year, Three-Year, and One-Year limited warranties are transferable to a subsequent owner, except the one-year Accessory warranty which is not transferrable and this Limited Manufacturer Warranty will not transfer to any new owner of a Boat which has been salvaged and resold, or resold after a declaration of a total loss or a constructive total loss, i.e., the cost of repair exceeds the value of the Boat. The new owner must fill out and submit the online Boston Whaler warranty transfer form, accessible from www.bostonwhaler.com. A copy of the bill of sale will be required to submit with the form. The warranty transfer must be completed within 30 days of purchase. Notwithstanding anything in this Limited Manufacturer Warranty to the contrary, Boston Whaler reserves the right to reject any warranty transfer request for a Boston Whaler Boat that has been damaged, neglected, or otherwise previously excluded from warranty.

MODIFICATIONS & SEVERABILITY

The terms and conditions contained herein, as well as those of any documents prepared in conjunction with the sale of this vessel may not be modified, altered or waived by any action, inaction, or representations, whether oral or in writing, except upon the expressed, written authority of a management level employee of Boston Whaler. The invalidity or unenforceability of any one or more of the provisions herein shall not affect the validity and enforceability of the other provisions.

GOVERNING LAW AND VENUE

This Warranty shall be interpreted and construed according to and governed by the laws of the State of Tennessee, without regard to conflict of law principles. Venue for any and all disputes arising out of or related to this Warranty, including without limitation the interpretation, performance or breach of this Warranty, shall be solely and exclusively before the United States District Court for the Eastern District of the State of Tennessee. The parties consent to the in personam jurisdiction of said court for the purposes of any such litigation and waive, fully and completely, any right to dismiss and/or transfer any action pursuant to 28 U.S.C. Section 1404 or 1406 (or any successor statutes) or the doctrine of forum non conveniens. If the United States District Court does not have subject matter jurisdiction of said matter, then such matter shall be litigated solely and exclusively before the appropriate state court of competent jurisdiction located in Knox County, Tennessee, and the parties consent to the personal jurisdiction of such court for the purpose of such litigation.



SAFETY

It is your responsibility (as well as the responsibility of any other operator of this Boat) to be familiar with and observe all local, state and federal laws, rules and regulations regarding boating, navigation and boating safety. You and any other operator of this Boat should take a course in boating and boating safety before operation of this Boat and should be completely familiar with all systems regarding safe operation of this Boat. Personal flotation devices should be worn by each passenger in accordance with U.S. Coast Guard standards and state and federal law.

World Headquarters
100 Whaler Way, Edgewater, FL 32141
(386) 428-0057
www.bostonwhaler.com

BOSTON WHALER LIMITED MANUFACTURER WARRANTY (Outside the U.S. or Canada)

Boston Whaler, Inc. (“Boston Whaler”) provides the following Limited Manufacturer Warranty to the original retail owner of its 2023 model year Boats, that if purchased from an authorized Boston Whaler dealer and operated under normal, non-commercial use, the authorized dealer will repair or replace, at its sole discretion, any defect in material or workmanship in the Boston Whaler Boat that is reported within the applicable Limited Manufacturer Warranty periods and within the scope as set out below.

Mandatory warranty rights, including a consumer’s mandatory statutory rights, by law are not affected by this Limited Manufacturer Warranty and in particular not limited or excluded. These mandatory legal rights exist regardless of whether a warranty claim occurs or rights are asserted under this Limited Manufacturer Warranty.

SCOPE

This Limited Manufacturer Warranty applies only to Boston Whaler Boats purchased outside of the US and Canada, including the territory of the European Union and Australia, and to recreational use customers only (not commercial users). Commercial use, which voids the Limited Manufacturer Warranty, is defined as any use of the product which generates income, even if the product is only occasionally used for such purposes.

Routine maintenance outlined in the Operation and Maintenance Manual must be timely performed in order to maintain Limited Manufacturer Warranty coverage. This Limited Manufacturer Warranty applies to the following items:

1. **Ten-Year Structural Hull Limited Warranty:** Any Structural Hull Defect in material or workmanship which is reported within ten (10) years from the date of sale to the original retail owner will be repaired or replaced at Boston Whaler’s sole discretion. The “Hull” shall mean the single fiberglass molded shell and integral structural components. A Structural Hull Defect shall mean a substantial defect in the Boat’s Hull which causes the Boat to be unfit or unsafe for general use as a pleasure craft under normal operating conditions
2. **Three-Year Limited Warranty on Components Manufactured or Installed By Boston Whaler (not applicable to 13 Super Sport or 16 Super Sport models):** Boston Whaler will repair or replace, at its sole discretion, any components manufactured or installed by Boston Whaler that are defective in factory materials and/or workmanship, which are reported within three (3) years from the date of sale to the original retail owner, and are not addressed in the specific warranties listed in paragraphs 1 or 4 or set out in the Exclusions paragraph below.
3. **One-Year Limited Warranty on Accessory Components for the 13 Super Sport and 16 Super Sport Models:** Boston Whaler provides the following Limited Warranty to the original retail owner of any factory-authorized accessory for the 2023 model year 13 Super Sport and 16 Super Sport, if purchased from an authorized Boston Whaler Dealer, authorized Boston Whaler website or any Boston Whaler affiliate and utilized under normal, non-commercial use (“Accessory”), subject to the remedies, exclusions, and limitations set out below. Boston Whaler will repair or replace, at its sole discretion, any Accessory that is defective in material or workmanship, which is reported within one (1) year from the date of sale to the original retail owner. Boston Whaler is not responsible for any defect and/or damage to the Accessory and/or the Boat caused by improper installation, whether performed by the retail consumer, dealer or any other third party.
4. **One-Year Limited Warranty on Upholstered Items, Canvas, Teak, and Powder Coating:** Boston Whaler will repair or replace, at its sole discretion, any upholstered items, canvas, teak, and powder coating manufactured or installed by Boston Whaler that are defective in factory materials and/or workmanship and are reported within one (1) year from the date of sale to the original retail owner.

5. Limited Engine Warranty: Retail owners will be entitled to the limited engine warranty as provided in the warranty manual from the engine manufacturer that was delivered to the original retail owner with his or her Boston Whaler Boat.

EXCLUSIONS

This Limited Manufacturer Warranty does not apply to any Boat which has been salvaged or declared a total loss or constructive total loss for any reason not covered in this limited warranty. This warranty also does not apply to the following items:

- 1) Expenses for hauling out, transportation to and from the dealer or the Boston Whaler factory for warranty service.
- 2) Equipment or accessories which are not installed by Boston Whaler or which carry their own individual warranties, including but not limited to engines, engine components, batteries, propellers, controls, steering mechanisms, and electronics.
- 3) Damage, deterioration, discoloration or mold of cushions or cosmetic surface finishes, including scratches, gouges, chips, chalking, blistering, cracking, crazing, fading or oxidation of gel coat, stress lines, plated or painted metal and stainless steel finishes, plastics or acrylic materials, or anti-fouling bottom paint.
- 4) Windshield breakage and leakage.
- 5) Any Boston Whaler Boat initially sold at retail by a party other than an authorized Boston Whaler dealer.
- 6) Damage resulting from abuse, misuse, improper rigging and installation by an owner or any other person or entity not being an authorized dealer, accidents, overloading or powering in excess of the recommended maximum horsepower.
- 7) Failure of the owner to use, maintain, or store the Boat as specified in the Boston Whaler owner's manual; and any other failure to provide reasonable care and maintenance. Normal wear and tear maintenance items are excluded from warranty coverage including but not limited to filters, bulbs, batteries, bungees, wiper blades, anchor rope, trailer finishes, tires, brakes, bearings and lights.
- 8) Damages due to failure to properly tow the Boat. For those Boats for which Boston Whaler offers a yacht tender package, damage due to towing when the package has not been installed.
- 9) Any Boston Whaler Boat which has been altered or modified from Boston Whaler factory specifications, including penetration of the hull by anyone other than Boston Whaler factory personnel or Boston Whaler authorized dealer service personnel following factory specified procedures.
- 10) Damage resulting from use of improper trailer, improperly placed supporting bunks or slings, incorrect bunks placement and improper Boat lift or sling.
- 11) Any Boston Whaler Boat used for commercial purposes, which includes, but is not limited to, any for-profit or other revenue-generating uses.
- 12) Any representation or implication relating to speed, range, fuel consumption or estimated performance characteristics.
- 13) Any failure or defect caused by an act of nature resulting in damage, cost, or expense;
- 14) Any failure or defect arising from a previous repair made by a non-authorized service provider.
- 15) Any item exceeding the expressed coverage limits specified in any Boston Whaler Limited Manufacturer Warranty.
- 16) Failure of the owner to use, maintain, or store an Accessory in reasonable fashion; and any other failure

to provide reasonable care and maintenance.

17) Any Accessory which has been altered or modified from Boston Whaler factory specifications.

18) Any Accessory not purchased from an authorized Boston Whaler Dealer, authorized Boston Whaler website, or authorized Boston Whaler affiliate. For a list of Boston Whaler's affiliates, please refer to www.brunswick.com.

19) Any Accessory used for commercial purposes, which includes but is not limited to, any for-profit or other revenue generating uses.

20) Any defect or repair requiring redesign of the Boat, except pursuant to the recall provisions of the United States Federal Boat Safety Act of 1971 or the recall laws of any other foreign jurisdiction.

ENVIRONMENTAL POLICIES

In keeping with environmental policies and practices, Boston Whaler reserves the right to utilize reconditioned, refurbished, repaired or remanufactured products or parts in the warranty repair or replacement process. Such products and parts will be comparable in function and performance to an original product or part and warranted for the remainder of the original warranty period.

ACCESS FOR SERVICE

The owner must provide Boston Whaler with a reasonable opportunity to repair, and reasonable access to the Boston Whaler Boat for warranty service. Warranty claims shall be made by delivering the Boston Whaler Boat for inspection to a Boston Whaler dealer authorized to service the product. If the owner cannot deliver the product to such a dealer, written notice must be given to Boston Whaler. Boston Whaler will then arrange for the inspection and any covered repair and the owner shall pay for all related transportation charges and/or travel time.

STATUTE OF LIMITATIONS

Without prejudice to your mandatory statutory rights, any action for rescission or revocation against Boston Whaler shall be barred unless it is commenced within one (1) year from the date of accrual of such cause of action, unless a longer period is prescribed by local law. This section shall not apply to Boston Whaler Boats purchased in Australia.

ASSIGNMENT OF COMPONENT WARRANTIES

Except as expressly set out herein, all warranties provided by the manufacturers and distributors of components, equipment, and parts on the Boat (collectively "Component Manufacturers") are hereby assigned to the owner to the extent permitted by the Component Manufacturers, as the owner's sole and exclusive remedy with respect to such items.

OWNER'S OBLIGATIONS

To initiate a warranty claim, it is the responsibility of the owner to contact an authorized Boston Whaler dealer immediately after discovery of any defect, describe the nature of the problem, and provide a hull serial number, date of purchase, and name of selling dealer. The authorized dealer will notify Boston Whaler, who is solely responsible for determining and authorizing in writing the remedial action(s) to be performed at either an authorized Boston Whaler dealership chosen by Boston Whaler or at the Boston Whaler factory. The owner should notify Boston Whaler of any Boat being repaired by an authorized Boston Whaler dealer which has been at the dealership for fifteen (15) days, or of any claimed defect which was not corrected after one repair attempt. Our privacy policies are available at www.bostonwhaler.com.

REGISTRATION & WARRANTY TRANSFER POLICY

The limited warranty coverage is activated by the authorized selling dealer registering the sale of a new Boat with Boston Whaler.

The Ten-year, Three-year, and One-year Limited Warranties are transferable to a subsequent owner, except the One-year Accessory Warranty which is not transferrable, and this Limited Manufacturer Warranty will not transfer to any new owner of a Boat which has been salvaged and resold, or resold after a declaration of a total loss or a constructive total loss, i.e., the cost of repair exceeds the value of the Boat. The new owner must fill out and submit the online Boston Whaler warranty transfer form, accessible from www.bostonwhaler.com. A copy of the bill of sale will be required to submit with the form. The warranty transfer must be completed within 30 days of purchase. Notwithstanding anything in this Limited Manufacturer Warranty to the contrary, Boston Whaler reserves the right to reject any warranty transfer request for a Boston Whaler Boat that has been damaged, neglected, or otherwise previously excluded from warranty.

MODIFICATIONS & SEVERABILITY

The terms and conditions contained herein, as well as those of any documents prepared in conjunction with the sale of this vessel may not be modified, altered or waived by any action, inaction, or representations, whether oral or in writing, except upon the expressed, written authority of a management level employee of Boston Whaler. The invalidity or unenforceability of any one or more of the provisions herein shall not affect the validity and enforceability of the other provisions.

SAFETY

It is your responsibility (as well as the responsibility of any other operator of this Boat) to be familiar with and observe all local, state and federal laws, rules and regulations regarding Boating, navigation and Boating safety. You and any other operator of this Boat should take a course in Boating and Boating safety before operation of this Boat and should be completely familiar with all systems regarding safe operation of this Boat. Personal flotation devices should be worn by each passenger in accordance with applicable standards and state and federal law.

THE FOLLOWING SECTION IS APPLICABLE TO AUSTRALIAN CONSUMERS ONLY

Boston Whaler Boats come with guarantees that cannot be excluded under the Australian Consumer Law. Retail owners are entitled to a replacement or refund for a major failure and compensation for any other reasonably foreseeable loss or damage. Retail owners are also entitled to have the goods repaired or replaced if the goods fail to be of acceptable quality and the failure does not amount to a major failure.

This Limited Manufacturer Warranty does not cover any expenses that retail owners may incur claiming the warranty.

The benefits to retail owners given by this Limited Manufacturer Warranty are in addition to other rights and remedies of the consumer under a law in relation to the goods or services to which the Limited Manufacturer Warranty relates.

**World Headquarters
100 Whaler Way, Edgewater, FL 32141
011 1 (386) 428-0057
www.bostonwhaler.com**

**CALIFORNIA EVAPORATIVE EMISSIONS
CONTROL SYSTEM WARRANTY STATEMENT**

YOUR WARRANTY RIGHTS AND OBLIGATIONS

The California Air Resources Board and Boston Whaler, Inc. are pleased to explain the evaporative emission control system's warranty on your 2023 MY spark-ignition marine watercraft (SIMW). In California, new spark-ignition marine watercraft must be designed, built, and equipped to meet the State's stringent anti-smog standards. Boston Whaler, Inc. must warrant the evaporative emission control system on your spark ignition marine watercraft for the period listed below provided there has been no abuse, neglect or improper maintenance of your spark-ignition marine watercraft.

Your evaporative emission control system may include parts such as: carburetors, fuel tanks, fuel lines, fuel caps, valves, canisters, filters, vapor hoses, clamps, connectors, and other associated components.

MANUFACTURER'S WARRANTY COVERAGE:

This evaporative emission control system is warranted for three years. If any evaporative emission-related part on your spark-ignition marine watercraft is defective, the part will be repaired or replaced by Boston Whaler, Inc.

OWNER'S WARRANTY RESPONSIBILITIES:

- As the spark ignition marine watercraft owner, you are responsible for performance of the required maintenance listed in your owner's manual. Boston Whaler, Inc. recommends that you retain all receipts covering maintenance on your SIMW, but Boston Whaler, Inc. cannot deny warranty solely for the lack of receipts.
- As the SIMW owner, you should however be aware that the Boston Whaler, Inc. may deny you warranty coverage if your spark-ignition marine watercraft or a part has failed due to abuse, neglect, or improper maintenance or unapproved modifications.
- You are responsible for presenting your spark-ignition marine watercraft to a Boston Whaler, Inc. distribution center or service center as soon as the problem exists. The warranty repairs should be completed in a reasonable amount of time, not to exceed 30 days. If you have a question regarding your warranty coverage, you should contact Boston Whaler, Inc. at 877-294-5645.

SIMW EVAPORATIVE EMISSIONS WARRANTY PARTS:

Fuel tank	Grade valves
Fuel feed hoses	Fuel fill deck plate w/cap and pressure relief valve
Fuel line fittings	Hose clamps on fuel system components
Fuel demand valves	Fuel level vent valve

All other parts not listed that may affect the evaporative emissions control system.

PRIVACY STATEMENT

Thank you for purchasing a boat or requesting information from Boston Whaler. This Privacy Statement is to inform you how we collect, use, disclose, and safeguard the personal information you provide to us through your purchases, requests for brochures, product registration cards, promotions, surveys, call centers, or other customer contacts. To see our full Privacy Policy and any updates, please visit www.bostonwhaler.com and select the Privacy Policy link. "Personal information" may include your name, age, mailing address, residential phone number, or e-mail address. It may also include income ranges, marital status, product or lifestyle preferences, and information concerning dealer service.

How we collect personal information: Our authorized dealer provided Boston Whaler or our company in the European Union with personal information collected at the time of your boat order/purchase with other product registration data and will continue to provide warranty and servicing information on your boat. We will send you customer satisfaction surveys which you may elect to return to provide us with information on your boat purchase and your servicing needs. Your personal information may be gathered by or shared with Boston Whaler's marketing providers and affiliated companies, who have comparable levels of privacy protection, for the purposes described in this statement. Boston Whaler, your dealer, and our marketing providers collect personal information when your request information about our companies and from surveys, promotions, contests, correspondence, your e-mails, telephone inquiries, web forms, and other communications. **How We Use and Disclose Personal Information:** Unless you advise us otherwise, Boston Whaler, our authorized dealers, affiliated companies, and our marketing providers may generally collect, use, disclose, hold, and file your personal information for the following purposes: (1) Providing goods, brochures, information, incentives, and/or services to you or on your behalf; (2) Fulfilling the terms of our limited warranty or other service obligation; (3) Facilitating recalls or service campaigns if necessary; (4) Reviewing goods and/or services provided to you in product, services, and marketing analyses; (5) Ensuring your satisfaction through surveys or other contacts; (6) Administration, billing, accounting, and collections; and protecting against fraud and error; and (7) Investigating a breach or a contravention of a law, complying with a subpoena, warrant, court order, or as required or otherwise permitted by law. Boston whaler will not sell your personal information or subject you to telemarketing or unsolicited e-mail.

Safeguards: We use security safeguards appropriate to the sensitivity of personal information to protect it from loss or theft, as well as prohibiting unauthorized access, disclosure, copying, use or modification of your personal information. These safeguards include restricted access to offices and equipment, security clearances, the use of passwords and/or encryption, publishing our privacy policy to appropriate personnel with instructions to act in accordance with its principles, and contractual provisions with our marketing agents and authorized dealers to follow the principles of our privacy policy.

Access and correction to your personal information: Subject to the exceptions provided by applicable law, we will provide, upon written request, your specific personal information collected in a form which is generally understandable. Your Personal Information is held by us and for us by our marketing agency, Rollick Company, who has contractually agreed to protect your information according to our privacy policies at the following addresses: Boston Whaler Inc., 100 Whaler Way, Edgewater, FL 32141. Please direct corrections, withdrawal of consent for specific purpose, complaints or other inquiries regarding personal information to: Rollick Company, 1078 Headquarters Park Drive, Fenton, MO, 63026; phone: (636) 343-9988, fax: (636) 326-3282. You can withdraw consent for us to use your personal information at any time or provide corrections upon providing to us a 30-day notice, unless withdrawing consent would impede the performance of legal obligations. We are required by law to provide you with information for product recall and other product safety relates purposes. The withdrawal of your consent may also adversely affect our ability to provide products and services to you and to maintain our relationship. Please note, notifying us will not result in withdrawing consent from your dealer, who should be contacted separately.

Obtaining consent: If any supplementary disclosure is required, we will obtain your consent for disclosure to other persons or organizations and for other purposes than stated herein, unless otherwise permitted by law.

Thank you for your business. We hope you have many years of wonderful boating experiences!

Owner's Packet

The owner's packet is a large, zippered bag that contains all the manuals and instructional information for non-Boston Whaler equipment and systems on your boat. Read and retain this information.

Owner's Manual

The contents of this manual:

• Provides basic boating safety information	• Details the boat's features and equipment
• Outlines the fundamentals of boat use	• Contains maintenance information

You must learn to operate this boat as well as read, understand and use this manual. This manual does not give you a course in boating safety or how to navigate, anchor or dock your boat. Operating a power boat safely requires more skills, knowledge, and awareness than is necessary for a motor vehicle.

Your Responsibilities

For the safety of you and your passengers, other boaters as well as people in the water, you must:

• Take a boating safety course	• Understand and follow the <i>rules of the road</i>
• Get instruction in proper boat handling	• Learn how to navigate

Contact Us

Boston Whaler, Inc.

877-294-5645

www.bostonwhaler.com

Warranties

In addition to the Boston Whaler Limited Warranty, each component and/or system on your boat has its own warranty that can be found with the specific information and manual for that component. These are included with your owner's information packet. Please locate, read, and retain the individual warranties.

Boating Information*

A comprehensive background in boating can be found in the book, *Chapman Piloting: Seamanship & Small Boat Handling*, by Elbert Maloney. For boating courses in North America, contact one of the following organizations:

Organization	Website	Phone
BoatU.S. Foundation	boatus.org	800-336-2628
U.S. Coast Guard	uscgboating.org	—
U.S. Coast Guard Auxiliary	cgaux.org	877-875-6296
US Power Squadron	usps.org	888 367-8777
Canadian Coast Guard	ccg-gcc.gc.ca	800-267-6687
Canadian Power and Sail Squadrons	cps-ecp.ca	888-277-2628
Red Cross	redcross.org	800-733-2767

State boating offices

Yacht clubs

*Outside of North America, contact your dealer or your governmental boating agency for assistance.

Safety Labels

The most important aspect of boating is safety. Although every effort is made to address the numerous issues regarding the safe usage of your boat, it is strongly recommended that you avail yourself of the training and knowledge available through boating safety courses, etc.

Warning Labels

Mounted at key locations throughout your boat are warning labels which advise the owner/operator of imperative safety precautions to follow when operating and/or servicing equipment.

The examples below indicate the level of hazard by color and explanation.

DANGER

Denotes an immediate hazard exists that **WILL** result in severe personal injury or death.

WARNING

Denotes hazards or unsafe practices that **MAY** result in severe personal injury or death.

CAUTION

Denotes hazards or unsafe practices that **COULD** result in minor personal injury, product or property damage.

NOTICE

Denotes information that is important to know prior to operation and/or maintenance, but is not hazard related.

Safety Precautions

The precautions below appear throughout this manual and must be observed when operating or servicing your boat. Learn to recognize the degree of precaution and understand the explanations of safety prior to reading this manual. These precautions are not all-inclusive. Always use common sense in the operation of your boat.

DANGER

Denotes an immediate hazard exists that **WILL** result in severe personal injury or death.

WARNING

Denotes hazards or unsafe practices that **MAY** result in severe personal injury or death.

CAUTION

Denotes hazards or unsafe practices that **COULD** result in minor personal injury, product or property damage.

NOTICE

Denotes information that is important to know prior to operation and/or maintenance, but is not hazard related.

ATTENTION

Denotes information found in the owner's manual to call attention to the safe operation or certain features of this vessel.

SAFE Boating means:

- Knowing the limitations of your boat
- Following the “RULES of the ROAD”
- Keeping a sharp lookout for people and objects in the water.
- Not boating in water or weather conditions that are beyond the boat’s and operator’s capability.
- Never operate the boat while under the influence of drugs or alcohol.
- Being aware of your passengers safety at all times.
- Reducing speed when there is limited visibility, rough water, people in the water nearby, boats or structures.

Boating in beautiful weather and calm water conditions can be a wonderful experience. Boating however requires considerably greater skills than operating a land vehicle.

To obtain these skills:

- Take a Coast Guard, U.S. Power Squadron or equivalent boating safety course. (Call the Boat/U.S. Foundation at 1-800 336-2628 for information on available courses, or go to: “www.boatus.com/foundation” on the internet.)
- Get hands-on training on how to operate your boat properly.

In Addition:

- Maintain your boat and its safety and other systems as recommended in this manual.
- Have the boat inspected by a qualified mechanic or dealer, at least annually.
- Ensure that the Coast Guard required safety equipment is on board and functioning.

Safe Boating Checklist

Before Departure

- Update checklists when equipment is added or modified.
- Weather-forecast safe
- Required documents-on board
- Navigation charts & equipment-on board
- Safety equipment-on board
- Safety training-passengers & crew instructed on procedures, location, and use of safety equipment.
- Drain plugs-installed
- Bilge pumps-working & clean
- Blower-working
- Navigation lights-working
- Horn-working
- Fuel system-no leaks or fumes
- Fuel filter-tight & clean
- Power steering fluid-filled(if applicable)
- Steering system-working smoothly & properly
- Battery-electrolyte level within range
- Float plan-filed with friend or relative

Trailer (if applicable)

- Boat position-secure on trailer
- Tiedowns-tight
- Winch-locked
- Trailer hitch-connected
- Engine clearance-in trailering position
- Safety chains-attached
- Electrical-Lights, brake lights, turn signals working
- Mirrors-adjusted for trailering

After Return

- PFD’s & other safety gear-dry, stowed for next use
- Fuel tanks-filled (allow for expansion) to prevent condensation
- Fuel system-no leaks
- Bilge pump-operating properly
- Bilge-clean, no leaks
- Float plan-notify person with whom you filed plan

General Considerations

- Know how your boat handles under different conditions. Recognize your limitations and the boat's limitations. Modify speed in keeping with weather, sea and traffic conditions.
- Instruct passengers on location and use of safety equipment and procedures.
- Instruct passengers on the fundamentals of operating your boat in case you are unable to do so.
- You are responsible for passenger's actions. If they place themselves or the boat in danger, immediately correct them.
- **Remember the "Rule of Thirds"**: Use one third of the fuel for the trip outbound, one third for the return trip, and keep one third for reserve.

Maintain Control

High performance boats require intimate knowledge of their handling characteristics for safe high speed operation.

- Learn the effects of trim, steering and throttle changes at gradually increasing levels of speed.
- Approach full throttle while adjusting trim for safe handling of the vessel.

On the water there are no marked traffic lanes, no traffic signs or lights, and boats have no turn signals. The boat operator must keep her or his attention focused not only on what's ahead but what's on the left, right and behind the boat.

The operator must always be alert to approaching boats (from the rear, right and left sides, as well as those ahead). There can be people in the water, partially submerged debris, and other navigational hazards such as rocks, sand bars or dangerous currents, to name a few.

Your passengers are relying on you to operate and maneuver the boat safely so that they are not in danger of going overboard. If you turn too quickly,

increase or decrease speed abruptly, your passengers are at risk of being thrown overboard or thrown about the boat.

When visibility becomes impaired because of weather or time of day, use navigational lights to ensure other boats can see you. In addition, if high bow angle causes reduced visibility, slow down to allow sufficient time to react if an emergency occurs.

Boarding

- Board only one person at a time.
- Never jump into boat. Step or climb into cockpit.
- Load gear after you are aboard. Carrying gear while boarding can cause you to lose balance.
- Distribute weight evenly.
- Instruct passengers where to sit during on-plane operation to reduce the possibility of falling overboard during high speed maneuvers.
- If gear is not immediately needed, stow it in secure areas.
- Safety gear must be immediately accessible at all times.

Impaired Operation

WARNING

CONTROL HAZARD-Federal laws prohibit operating a boat while under the influence of alcohol or drugs. These laws are vigorously enforced.

The detrimental effects of alcohol and drugs are increased by wind, waves and sun, and will decrease your response time and ability to act in critical situations. Give special attention to the effects of alcohol and drugs while boating. No other single factor causes as many marine accidents and deaths. Death or serious injury and damage to personal and private property can result from being impaired while operating a boat.

Operator's Responsibility

Your degree of enjoyment on the water depends on you, your equipment and other people who, like yourself boat responsibly. As a boat operator you should:

- Make sure that all occupants always wear a U.S. Coast Guard-approved life jacket while on the water.
- All boat operators should complete a boating safety course (a requirement in many states).
- All boat operators must become familiar with the proper operation of all vessel features prior to departure.
- Always maintain a safe speed.
- Be aware of conditions in every direction always when underway.
- Mind your wake. It can capsize a small boat or damage moored boats or other property. You are responsible for damage caused by your wake.
- Reduce speed and post a lookout to identify hazards when:
 - Visibility is impaired
 - In rough water
 - In congested waterways
- Display navigation lights between sunset and sunrise and during periods of restricted visibility, such as rain, fog, etc.

WARNING

A qualified operator must be in control of the boat at all times. Do not operate the boat while under the influence of alcohol or drugs. never operate your boat at speeds which exceed the operator's ability to react if an emergency develops. At night, turn on the appropriate navigation lights and cruise at a reduced speed that will allow you plenty of time to avoid dangerous situations.

WARNING

STABILITY HAZARD

- **Load boat properly. The manufacturer's load rating is the maximum allowed under normal conditions. Adjust downward if weather, water or other conditions are adverse.**
- **Allow passengers to ride only in areas that do not pose a hazard to themselves or the boat.**

DO NOT allow passengers to ride on the bow of a closed bow boat.

DO NOT allow several passengers to ride in the bow of a small open-bow boat, causing the boat to "plow" into the water.

DO NOT allow passengers to ride on the stern cushion or gunwales.

DO NOT overload the stern.

- **Observe manufacturer's recommended on-plane seating locations.**
- **Passengers should remain seated while boat is moving.**

PERSONAL INJURY HAZARD-Stay alert. Use of drugs, alcohol, or other substances which impair judgement poses a serious threat to yourself and others. The boat operator is responsible for the behavior of passengers.

DROWNING HAZARD-Boats must carry one wearable personal flotation device (PFD) for every passenger on board. Boats must have at least one throwable life preserver.

SLIPPING HAZARD-Wet decks are slippery. Wear proper footwear and use extreme caution on wet surfaces.

Legally Mandated Equipment (Minimum Required)

Consult your National Boating Law Enforcement Agency. The following equipment is the minimum required by the U.S. Coast Guard for a boat which is more than 26 ft. (7.9M) in length but less than 40 ft. (12.2M) in length.

Personal Flotation Devices (PFD's)

One (1) Coast Guard approved Type I, II, III is mandatory for each person aboard.

One (1) throwable Type IV device is also required to be onboard.

A Type V device is acceptable if worn for approved use.

ALWAYS WEAR A PFD WHEN BOATING.

WARNING

There is rarely time to reach stowed life jackets in time of emergency. Boaters should always wear a properly fitting, approved life jacket when on the water.

Children and non-swimmers MUST wear PFD's at all times when aboard.

NOTICE

Depending on the state or country of operation, the operator of a vessel may be fined for failure to comply with local or national rules regarding PFD usage.

Fire Extinguishers (Portable)

If there is no fixed fire extinguishing system installed in the engine or generator spaces, the Coast Guard requires two (2) Type B-I or one (1) B-II fire extinguisher(s) be on board.

The American Boat & Yacht Council (ABYC) recommends that you carry three (3) A,B or C Type fire extinguishers on board and located within easy reach of the helm, Engine(s), and galley or passenger cockpit.

Whistle, Horn

You must have on board, some means of making a loud sound signal. Navigation rules require that a sound made by any audible device be capable of a four (4) second blast, and be audible for 1/2 mi. (.80 Km).

Visual distress Signals

If you operate your boat in coastal waters or on the Great Lakes, you must have a visual distress signals for day and night use on board. At least three (3) U.S.C.G. approved pyrotechnic devices marked with date showing service life must be carried, be readily accessible, in serviceable condition and not be expired.

Store all pyrotechnic signals in a well marked, waterproof container.

Additional Recommended equipment for safe operation

In addition to the legally mandated equipment, the following items are necessary for safe boating, especially if your boat is out of sight of land.

- First Aid kit
- Charts/Maps
- Visual distress signals (for day or night use)
- Marine VHF radio
- Moisture repellent
- Mooring Lines
- Fenders
- Waterproof flashlights
- High power spotlight
- Spare propeller
- Tool kit:
 - Screwdrivers, (Phillips & flat)
 - Pliers, (regular, vise-grip, tongue & groove)
 - Wrenches, (box, open end, allen & adjustable)
 - Socket set, (metric or U.S.)
 - Electrical tape & duct tape
 - Hammer
 - Spare parts kit, (spark plugs, fuses, etc.)
- Compass
- Manual bilge pump
- GPS or LORAN
- Spare keys
- EPIRB-Emergency positioning-indicating radio beacon
- Boat hook
- Extra batteries
- Instruction manuals
- Lubricating oil
- Anchor

Carbon Monoxide (CO)

⚠ DANGER

- **Fumes from engine(s), Generator(s) and other equipment and appliances that burn fuel contain Carbon Monoxide. Carbon Monoxide can kill you. Open all doors, hatches, curtains and windows to allow fresh air to circulate and dissipate the amounts of Carbon Monoxide present in enclosed spaces, especially when the boat is moored or anchored.**
- **Proper ventilation must be maintained, even during inclement weather to prevent dangerous levels of Carbon Monoxide build-up.**
- **Sleeping aboard a boat requires a working Carbon Monoxide detection system, preferably in each sleeping quarter.**

Carbon Monoxide is an odorless, colorless, extremely toxic gas that is the product of any type of combustion produced by engines, heaters, stoves or generators. When inhaled it combines with hemoglobin in the blood, preventing absorption of oxygen and resulting in asphyxiation and death.

Prolonged exposure to low concentration or very short exposure to high concentrations can result in asphyxiation and death.

Symptoms of Carbon Monoxide poisoning include:

- Dizziness
- Headaches
- Ringing in the ears
- Nausea
- Unconsciousness

GET MEDICAL ATTENTION AS SOON AS POSSIBLE.

Symptoms of CO poisoning are often confused with seasickness or intoxication, so those affected may not receive the medical attention they need.

The poisoning victim's skin often turns cherry red. If CO poisoning is suspected, have the victim breathe fresh air deeply. If breathing stops, resuscitate. A victim often revives, then relapses because organs are damaged by lack of oxygen.

Carbon Monoxide can accumulate in dangerous concentrations anywhere in or around your boat including on back decks, swim platforms, or in water around generator exhausts. CO can remain in or around your boat at dangerous levels even if your engine is no longer running.

Remember:

- If you can smell engine exhaust, you are inhaling CO.
- Changing course and speed to place boat heading into the wind can improve ventilation.

To minimize the danger of Carbon Monoxide accumulation when the Engine is running (or by use of fuel burning equipment.):

- Do not idle the engine without moving the boat for more than 15 minutes at a time.
- Inspect the exhaust system regularly.
- Operate all fuel burning appliances, such as charcoal, propane, LPG, CNG or alcohol cooking devices in areas where fresh air can circulate.

Carbon Monoxide Detector

The Carbon Monoxide Detector located on the forward galley cabinet will sound an alarm when dangerous levels of CO are detected. The detector is very sensitive and will notify you before dangerous amounts of Carbon Monoxide can accumulate which will allow you to take measures to dissipate the gas from the affected areas. Read and understand the warnings and recommendations presented in this section to help keep yourself and your passengers safe from carbon monoxide.

Testing:

At least once a week depress the "Test/Mute" button until the green LED turns on and release to determine if the detector is working properly.

The alarm will simulate 2 alarm cycles (2 sets of 4 beeps, 5 sec. silence between). The Red LED will flash once every 5 seconds.

Maintenance:

Avoid spraying liquids directly on alarm.

End Of Life Signal

Your CO detector is equipped with an end of life signal indicating the sensor used in the unit has reached the end of its service life and must be replaced. The detector contains an electrochemical sensor that will last approximately seven years. Refer to your unit's operation manual for end of life signal indication and further information and instructions.

The end of life signal can be deactivated so that it does not alarm. Deactivating the CO alarm is permanent. Reactivating is not possible. Do not deactivate unless you have a replacement alarm available to install.

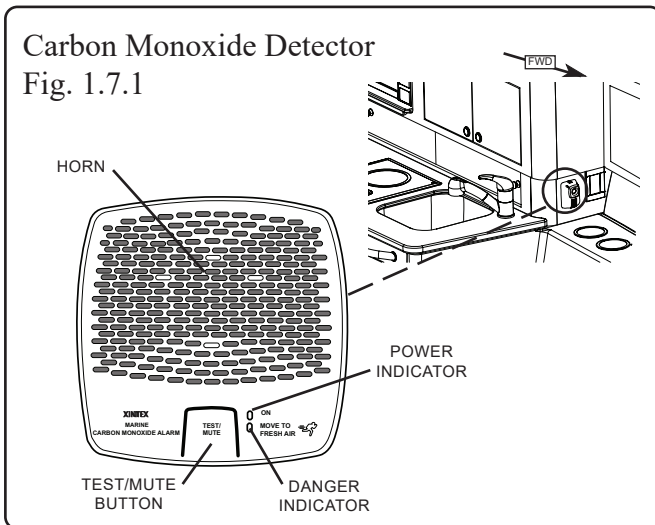

⚠ DANGER

Even in rainy cold weather, ventilation must be maintained to avoid Carbon Monoxide poisoning. You will get wet and/or cold.

⚠ DANGER

Never ignore an alarm.

In the event the CO alarm activates:

- Evacuate enclosed areas immediately.
- Shut OFF any fuel burning equipment or appliances.

- Open hatches, doors, port lights, etc. to improve ventilation.
- If making way, head boat into the wind.

Carbon Monoxide Accumulation Scenarios

Examples of accumulation of Carbon Monoxide
Fig. 1.7.2

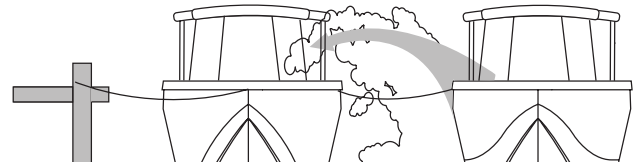

EXHAUST FROM OTHER BOATS

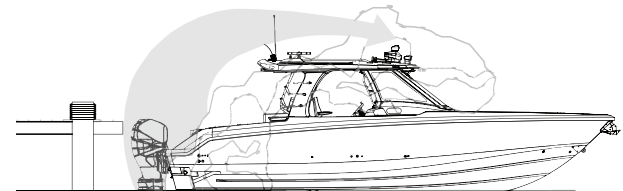

BLOCKAGE OF EXHAUST BY OBSTRUCTION

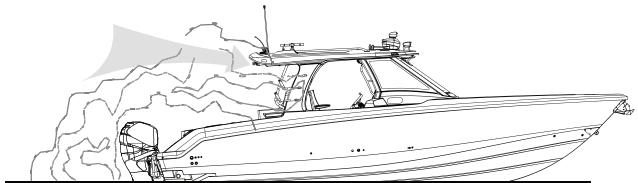

OPERATING AT A HIGH BOW ANGLE

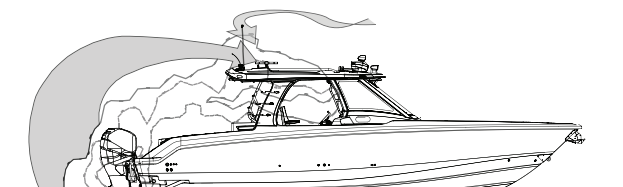

OPERATING AT SLOW SPEED OR WHILE IDLING
(STATION WAGON EFFECT)

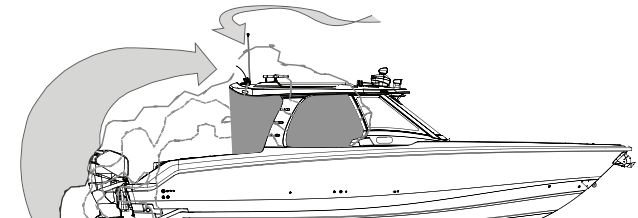

RUNNING OR AT IDLE
WITH CANVAS INSTALLED

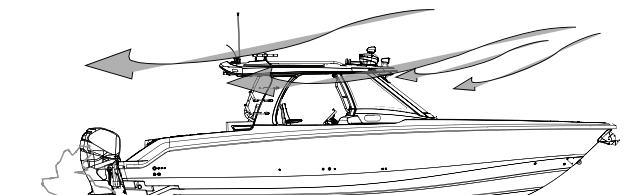

GOOD AIR FLOW

Dangerous concentrations of Carbon Monoxide will be present if the engine(s) exhaust system leaks OR insufficient fresh air is circulating.

To minimize the danger of Carbon Monoxide accumulation when the Engine(s) and/or Generator are running (or by use of fuel burning equipment.):

- Be sure to have sufficient ventilation when using canvas enclosure.
- Open all forward hatches and leave cabin door open.
- Operate all fuel burning appliances, such as charcoal, propane, LPG, CNG or alcohol cooking devices in areas where fresh air can circulate.
- Do not idle the engine(s) without moving the boat for more than 15 minutes at a time.
- Inspect the bilge blower, located aft of the generator in the equipment compartment.

DANGER

Even in rainy cold weather, ventilation must be maintained to avoid Carbon Monoxide poisoning. You will get wet and/or cold.

Lifesaving Equipment

PFD Requirement

Even strong swimmers can tire quickly in the water and drown due to exhaustion, hypothermia, or both. The buoyancy provided by a personal flotation device (PFD) will allow the person who has fallen overboard to remain afloat with far less effort and body heat loss, extending survival time necessary to find and retrieve them.

One (1) wearable personal flotation device (PFD, Type I, II, III or V) for every person onboard and at least one (1) throwable device, (Type IV).

The law requires that PFD's must be readily accessible, if not worn. "Readily Accessible" means removed from storage bags and unbuckled. **Children and non-swimmers must wear PFD's at all times when aboard.**

Listed below are the several different types of PFD's, each life jacket has different purposes, choose one that will suit your purpose.

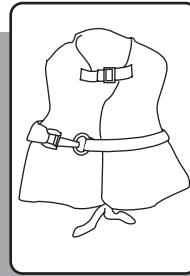

Type I, Off-shore Life Jacket is considered the most buoyant, it is designed to turn an unconscious person face up. Use in all types of waters where rescue may be slow, particularly in cold or rough water conditions.

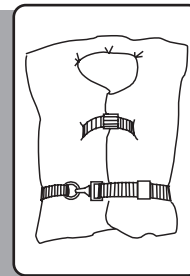

Type II, Near-shore Life Vest, "keyhole" vest with flotation filled head and neck support is also designed to turn a person face up, but the turning action is not as pronounced. Use in calm inland waters or where quick rescue is likely.

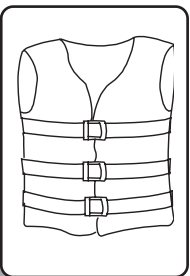

Type III, Flotation-aid Life vest is designed so that conscious wearers can turn face-up. Designed for comfort while engaged in water skiing or other forms of water activities.

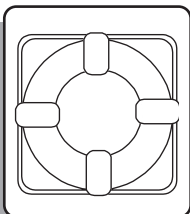

Type IV, Throwable Devices, horseshoe buoys, ring buoys and buoyant cushions are designed to be grasped, not worn.



Type V, Special-Use devices, sailboat harnesses, white water vests, float coats, and hybrid vests which have minimum inherent buoyancy and an inflatable chamber.

Before purchasing PFD's, ensure that there is an attached tag indicating they are approved by the U.S. Coast Guard or by your National Boating Law Enforcement Agency.

The operator is responsible for instructing everyone onboard on the location and use of the PFD. **The best precaution is to wear the PFD at all times while on the boat.**

Children and non-swimmers must wear a PFD at all times when aboard. All passengers and crew should wear them since an unworn PFD is often useless. The law requires that PFD's, if not worn must be readily accessible, that is, removed from storage bags and unbuckled. Throwable devices must be readily available, that is, right at hand.

General Considerations

- Know how your boat handles under different conditions. Recognize your limitations and the boat's limitations. Modify speed in keeping with weather, sea and traffic conditions.
- Instruct passengers on location and use of safety equipment and procedures.
- Instruct passengers on the fundamentals of operating your boat in case you are unable to do so.
- You are responsible for passenger's actions. If they place themselves or the boat in danger, immediately correct them.

WARNING

A qualified operator must be in control of the boat at all times. Do not operate the boat while under the influence of alcohol or drugs. Never operate your boat at speeds which exceed the operator's ability to react if an emergency develops. At night, turn on the appropriate navigation lights and cruise at a reduced speed that will allow you plenty of time to avoid dangerous situations.

WARNING

STABILITY HAZARD

- **Load boat properly. The manufacturer's load rating is the maximum allowed under normal conditions. Adjust downward if weather, water or other conditions are adverse.**
- **Allow passengers to ride only in areas that do not pose a hazard to themselves or the boat.**

DO NOT allow passengers to ride on the bow of a closed bow boat at speeds over 5 mph.

DO NOT allow several passengers to ride in the bow of a small open-bow boat, causing the boat to "plow" into the water.

DO NOT allow passengers to ride on the stern cushion or gunwales.

DO NOT overload the stern.

- **Passengers should remain seated while boat is moving.**

PERSONAL INJURY HAZARD-Stay alert. Use of drugs, alcohol, or other substances which impair judgement poses a serious threat to yourself and others. The boat operator is responsible for the behavior of passengers.

DROWNING HAZARD-Boats must carry one wearable personal flotation device (PFD) for every passenger on board. Boats must have at least one throwable life preserver.

SLIPPING HAZARD-Wet decks are slippery. Wear proper footwear and use extreme caution on wet surfaces.



WARNING

Death or serious injury can result if you fail to observe these safety rules:

- **Anyone who controls the boat must have taken a boating safety course and have trained in the proper operation of the boat.**
- **Always operate the boat at speeds that will not put people or property in danger.**
- **Be constantly aware of conditions in all directions when underway and before turning.**
- **Reduce speed, use a lookout to identify possible hazards or difficulties, and turn on navigation lights when:**
 - **visibility is impaired;**
 - **in rough water; and**
 - **in congested waterways.**
- **Watch your wake. It can capsize a small boat or damage moored boats or other property. You are responsible for damage caused by your wake.**

Emergency Situations

NOTICE

The law requires the owner/operator to assist any person or boat in distress as long as rendering assistance does not endanger the owner/operator, the passengers or the boat.

Prevention is the safest approach. We hope that you are never involved in an emergency situation, but if you are it is imperative that you react.

Medical Emergency

You may be far from professional medical help when you are boating. At least two (2) persons on board your boat should be CPR certified, and should have taken a first aid course. Your boat should have a well

stocked first aid kit on board. In many situations your radio will be your only link to reaching medical assistance. Keep the radio in working order and understand which channels are used for emergencies, these channels are constantly monitored and will be useful when situations arise. Cell phones are becoming more common and can help in some areas, but they are limited and unreliable and should not be used in the place of a good VHF radio.

Water Rescue

In most situations a person that has fallen overboard will succumb to hypothermia if not rescued immediately. Life expectancy decreases as rescue time increases in water temperatures below 70° (21.1°C).

There are three (3) steps that must be taken when a person has fallen overboard:

Returning to the Victim:

- Immediately make everyone onboard aware that someone is overboard and keep the victim in sight.
- Slow the boat and keep pointing toward the person overboard. At night or in low light, point the best available light source at the person.
- Throw a life ring/preserver to the victim, even if they are wearing one it will serve as another marker.

Making Contact

- Stop or slow the boat and circle toward the person overboard.
- Try to approach heading into the wind or into the waves.
- Keep person overboard constantly in sight.
- When almost alongside, turn off the engine in gear to prevent propeller windmilling.

Getting Back Aboard

- Try to reach the person overboard with a pole, or by throwing a life preserver. NEVER swim to them except as a last resort.

- Assist the person in boarding. Boarding should be done at the stern of the boat.
- If the person is injured or incapable of boarding by themselves, a rescuer should don a life preserver with a safety line and enter the water to assist the person onto the boat.
- Handle the person carefully, spinal injuries might have occurred and could be worsened by rough handling.
- Check for other injuries, render medical assistance immediately.

Unassisted Reboarding

The transom ladder (See figure 3.41.2) can be deployed to accommodate a person reboarding the boat without assistance.

Fire

Fire is a serious boating hazard. Boats will burn quickly. Do not remain onboard and fight a fire for more than a few minutes. If the fire is out of control and cannot be put out with the fire suppression equipment onboard, abandon ship immediately.

The fumes released during a fire are toxic and should be avoided. Even after the fire has been extinguished, proper ventilation of the area is required to minimize exposure to harmful fumes.

DANGER

- **Fires can spread quickly. Your reaction to the fire is important. Have the proper fire fighting equipment close at hand, and in good working order to respond quickly.**
- **Small fire extinguishers have small discharge times. Aim at the base of the fire with a sweeping motion to maximize the use of the fire extinguisher contents.**

To lessen the danger of fire

- Extinguish all smoking materials, shut off blowers, stoves, engine(s) and generator(s).

- Keep bilge area clean, oil and fuel spills should be cleaned immediately.
- If possible throw burning materials overboard.
- If fire is accessible, release the contents of the fire extinguisher(s) into the base of the fire.
- If the fire is in an enclosed compartment, and you have an automatic extinguisher for the compartment, wait 15 min. before opening the compartment. Have an extinguisher handy in case of a flare up.
- If possible, signal for help. Radio, visual, and audible signal should be used as needed. You must render assistance to any boater requesting help.
- If fire is out of control, grab all necessary survival gear, distress signals, don your PFD's and prepare to abandon ship.
- If you do abandon ship, make sure the passengers have PFD's. Take a head count before entering the water and take another head count when in the water. **STAY TOGETHER.**

Flooding, Swamping and Capsizing

In the event of Flooding, Swamping or Capsizing:

Flooding

- Always wear your PFD, or have it within reach.
- If the bilge pump(s) have not automatically turned ON, switch them ON immediately.
- Find the source of the flooding and determine the best fix.
- Keep the bilge pumps running until the flooding is under control.
- Call for assistance if the source of the flooding cannot be controlled.
- Head back to port if possible.

Swamping

- Always wear your PFD, or have it within reach.

- Swamping is usually a result of wave action, immediately get control of the helm and turn the boat into the waves.
- Swamping can also be caused by an overloaded boat.
- If the bilge pump(s) have not automatically turned ON, switch them ON immediately.
- The deck scuppers on your boat are designed to drain the deck of water.
- Keep the bilge pumps running until the flooding is under control.
- Take a head count of all passengers.

Capsizing

- “Capsized” is when a boat is on its side or completely upside-down (usually as a result of wave action, improper loading or load shifting).
- Always wear your PFD, or have it within reach.
- If the boat will not right itself, get out of the water and climb onto the exposed hull.
- Do a head count for all passengers
- **STAY TOGETHER**
- Usually a capsizing will happen quickly and without warning.
- Use whatever is at hand to signal for help.

The chances of flooding, swamping or capsizing can be reduced by being aware of:

- Weather
- Water Conditions
- Proper boat handling techniques
- Proper loading of the boat

Collision

In the event of collision:

- Cut the engine(s)
- Always wear your PFD, or have it within reach.

- Check on passengers
- If the bilge pump(s) have not automatically turned ON, switch them ON immediately.
- Determine the amount of damage to your boats structure.
- Call for assistance
- In the event of collision you are required to file an accident report. Contact a state enforcement agency or the nearest U.S. Coast Guard office. If you are boating outside U.S. waters, consult the nation you are visiting for accident reporting requirements.

Propulsion, Control or Steering failure

If there is a propulsion, control or steering failure:

- Stop the engine, (shut off at Ignition or pull on the Emergency Engine Shut-Off Switch.)
- Drop anchor to prevent drifting.
- Determine if the problem can be fixed or will assistance be needed.
- Call for assistance if needed.

When loss of propulsion or steering is noticed, your quick reaction is required to prevent further damage to your boat or injuries to your passengers.

Outboard engines require propulsion to control the direction the boat will take. Without propulsion, the steering is virtually useless. If you are in a congested waterway you will need to react quickly to warn others that you have lost power, propulsion or steering control and that assistance will be needed.

Grounding

Running aground may be avoided by paying attention to marker buoys or indicated by waves as they form into breakers when passing over a sand bar.

If you do run aground, the course of action depends on how hard the boat hits bottom and whether the boat remains stranded. If it is a simple touch, you may need only to inspect the lower drive of the engine and the hull of the boat. If possible do a thorough

inspection before trying to get loose, throwing the boat into reverse before this is done may do more damage.

Distress Signals

Visual Distress Signals, (VDS)

- U.S. Coast Guard regulations require boats in coastal waters and the Great Lakes to carry a Visual Distress Signal (VDS) for day and night use, as well as appropriate for the time of operation. Exempt from the day signals requirement, but not night signals, are boats less than 4.8 meters (16 feet), open sailboats less than 7.9 meters (26 feet), boats participating in organized events and manually propelled boats.
- If you are required to have visual distress signals, at least three safety approved pyrotechnic devices in serviceable condition must be readily accessible. They must be marked with a date showing the service life which must not be expired.
- Carry three signals for day use and three for night use. Some pyrotechnic devices such as red flares, meet both day and night use requirements.
- Store pyrotechnic signals in a cool, dry location. An orange or red watertight container prominently marked “DISTRESS SIGNALS” is recommended.

Other recognized visual distress signals include:

- Flames in a bucket
- Code flags November & Charlie
- Black square & ball on orange background flag
- Orange flag (certified)
- Electric distress light (certified)-for night use
- Dye marker (any color)
- Person waving arms (slowly)
- U.S. ensign flown upside down

Audible Distress Signals, (ADS)

U.S. Coast Guard regulations require one hand, mouth or power operated whistle or horn, audible for at least 1/2 mile.

Other recognized audible distress signals include:

- Radio communication (see **Radio Communication** below)
- Radio-telegraph alarm
- Position indicating radio beacon
- Morse Code S-O-S (3 short 3 long 3 short) sounded by any means.
- Fog horn sounded continuously.

Radio Communication

A radio is the boat operator’s main method of receiving safety information and summoning aid. VHF-FM radio is the primary means of short range communication. Single sideband radio (SSB) is used for longer range communication.

VHF-FM channel 16 and SSB 2182 kHz are designated for emergency use. Such situations can be categorized as:

- **EMERGENCY-**
“**MAYDAY, MAYDAY, MAYDAY,**”- used when life or vessel is in imminent danger.
- **URGENCY-**
“**PAN-PAN, PAN-PAN, PAN-PAN**” (pronounced PAHN-PAHN)-used when a person or vessel is in some jeopardy less than indicated by a “MAYDAY” call.
- **SAFETY-**
“**SECURITY, SECURITY, SECURITY**” (pronounced SAY-CURE-IT-AY)-used for navigational safety or weather warning.

An emergency situation will be hectic and there will not be time to learn proper radio procedure. Learn what to do before you need to do it. If you hear a

distress call, stop all radio transmissions. If you can directly assist, respond on the emergency frequency. If you cannot assist, do not transmit on that frequency. However, continue to monitor until it is obvious that help is being provided.

⚠ WARNING

NEVER operate a boat at a speed at which you do not feel in control.

Weather

⚠ DANGER

DO NOT attempt to boat in severe weather conditions. Death or serious injury can occur. Get to shore before the weather turns bad.

Getting caught in severe weather is hazardous. Bad weather and/or rough sea or water conditions can cause an unsafe situation. Consult local weather services for up-to-date forecasts on weather and sea conditions. Television, Radio, and the Internet can give you access to NOAA weather reports that will help you make a determination on where and when to get underway.

Following are some weather related rules:

- Understand the design limitations of your boat.
- Check the weather forecast and water conditions before leaving and while underway.
- Wear a Personal Flotation Device (PFD)
- If a storm approaches, immediately seek a safe harbor.
- If a storm hits have everyone sit in the cabin or cockpit deck in the boat. Head the bow into the wind with enough power to maintain slow headway.
- If you encounter fog, determine your position, set a safe course, slow down and alert other boats of your presence with a sound signal.
- If a lightning storm approaches, the safest action is to dock and disembark. If you cannot return to shore, have passengers go inside the cabin and remain there until the storm passes.

- Stay out of the water during a lightning storm. If caught swimming during a storm, get back into the boat and remain there until the storm passes. (Remember that lightning can strike several miles away from the storm itself. Be aware of the storms location relative to your location and the direction the storm is moving).



⚠ WARNING

A sudden change in wind direction or speed or an increase in wave height indicates deteriorating weather.

NOTICE

Check the weather forecast and water conditions before leaving and while underway

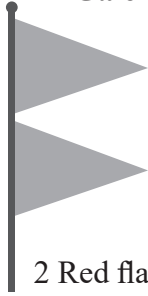
Weather Warning Pennants
Fig. 1.14.1

 Red flag- winds to 33 knots (38 mph).	<p>Gale</p>  2 Red flags winds 34 - 47 knots (38 - 54 mph)
<p>Storm</p>  Square Red flag w/Black box winds 48 - 63 knots (55 - 73 mph)	<p>Hurricane</p>  Two square red flags w/black box winds 64+ knots (74+ mph)

Swimming, Diving and Water Skiing

Swimming

- Do not swim from a moving boat.
- Many areas prohibit swimming from a boat except in designated areas.
- Turn off engine in gear (to prevent propeller “windmilling”) before picking up swimmer.

Diving

Recognize and respect diving flags. Keep at least 30 meters (100 ft.) away.

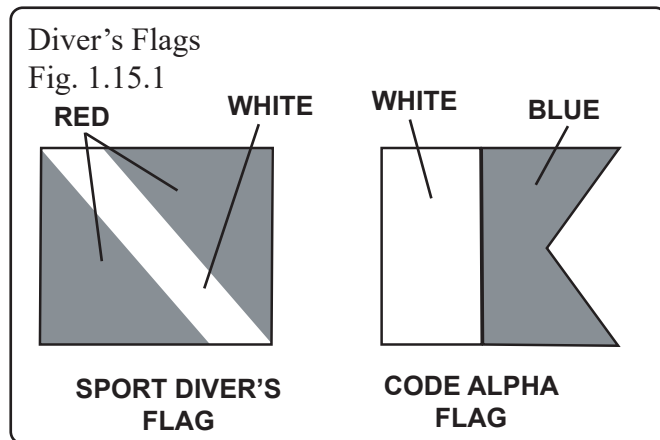

SPORT DIVERS FLAG-Red flag with diagonal white stripe marks a diver in the water.

CODE ALPHA FLAG-Blue and white pennant designates boat being used in dive operations.

Water Skiing

- Always have two persons in the boat, one at the controls and one who can easily and continuously look at the skier.
- Insist that anyone who water skis must know how to swim.
- Insist that skiers wear approved Personal Flotation Devices (PFD's)
- Ski only in daylight when visibility is good.
- Never drive the boat directly behind a water skier. At 22 knots (25 m.p.h.), it takes only 5 seconds to overtake a fallen skier who was 60 meters (200 feet) in front.
- Ski only in areas where skiing is permitted.

Water Skiing Signals

Skiing Signals

Fig. 1.15.2

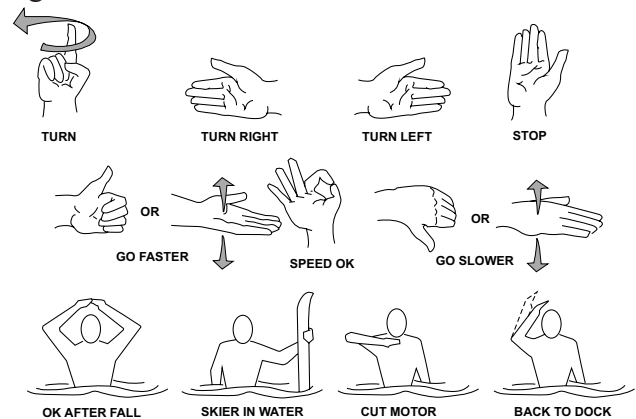

Turn – Arm raised, circle with index finger extended.

Turn Right – Extend arm out from body to the right.

Turn Left – Extend arm out from body to the left.

Stop – Raise arm with palm vertical and facing forward.

Faster – Thumb pointed up or palm up, move hand up and down.

Speed OK – Raise arm and form a circle with thumb and index finger.

Slow Down – Thumb pointed down or palm down, move hand up and down.

OK After a Fall – Clasp hands together overhead.

Skier in Water – Extend one ski vertically out of water.

Cut Motor – Draw finger across throat.

Back to Dock – Pat top of head.

- Observe local restrictions on length of tow line.
- Learn the signals to communicate with a skier. The skier is to control the boat through hand signals (Figure 1.15.2).
- Your boat will handle differently while towing a skier. Experiment carefully to learn the difference.

- Skiers may start from the shore or dock, if boat traffic allows. When returning, pick up skiers from water. Do not ski back to shore or dock.
- Give immediate attention to fallen skiers.
- Keep a downed skier in sight and on the operator's side of the boat when approaching the skier. **Never back up to anyone in the water.**
- Turn off engine in gear (to prevent propeller "windmilling") before picking up skier.
- If the skier suddenly releases the tow rope, it can backlash into cockpit. Spotters who are watching the skier must be aware of this fact and be prepared to take appropriate action to avoid injury.

DANGER

PROPELLER SAFETY

- **Before starting your boat, walk to the stern and look in the water to assure there is no one near your propeller.**
People near propeller may not be visible from helm.
- **NEVER allow passengers to board or exit your boat from the water when engines are on.**
- **Educate passengers about the dangers of propellers**
- **Be especially alert when operating in congested areas. NEVER enter swimming zones.**
- **Take extra precautions near boats that are towing skiers or tubers.**
- **NEVER permit passengers to ride on the bow, gunwale, transom, seatbacks, or other locations where they may fall overboard.**
- **STOP! If someone falls overboard. Slowly turn the boat around, and keep the person in sight as you approach. Turn your engine off FIRST and then bring the person aboard.**
- **NEVER reverse your boat to pick someone up out of the water.**

WARNING

SWIMMING/DIVING HAZARD

- **Keep clear of areas designated only for swimmers and skin divers. Recognize markers used for such areas.**
- **Never swim when there is lightning in the area.**

SKIING HAZARDS

- **Skiers must use a safety approved Personal Flotation Device (PFD).**
- **Ski only during daylight and in good visibility.**
- **Avoid shallow water, other boats, navigational aids and other obstructions.**
- **Keep at least 30 meters (100 ft.) from other objects.**
- **Never drive directly behind a water skier.**
- **A competent observer must watch the skier at all times. A competent observer is a person that has the ability to assess when a skier is in trouble, knows or understands water skiing hand signals and is capable of helping a skier.**
- **Keep a downed skier in constant sight.**
- **Turn off engine in gear before you get close to person in the water.**
- **Never back up to anyone in the water.**
- **Use caution in boat when skier is being towed. Sudden release of tow rope can cause it to backlash into the cockpit.**

PERSONAL INJURY HAZARD

Use transom tow ring only to pull water skiers. Unless specified by the manufacturer, any other use, such as parasailing, kite flying, towing other boats, etc. may create too much stress on the tow ring, resulting in personal injury and/or equipment damage.

Towed Inflatables

Towed inflatable types, aka tubes, produce tremendous stress on the tow point and rope, far greater than devices like water skis, kneeboards or wake boards. When pulling a tube use both stern eye strong points in combination with a proper tube harness and tow rope. Parasails and kites should never be used with a recreational boat.

ATTENTION

Personal Injury/Equipment Damage

Ski tow pylons/tower/hardtop/ski eye tow points are not designed for use with tubes. The added stress of the tube may cause a dangerous recoil or damage the equipment. Damage to the pylon/tower/hardtop/ski tow eye is not covered by the boat or equipment manufacturer's warranty. When towing inflatables/tubes, use both stern eye strong points with a tube tow harness to attach the tube tow rope.

Engine Emergency Safety Cut-Out Switch

! WARNING

Wear the lanyard at all times when operating the boat. Use it to stop only in an emergency. DO NOT use it to shut off the engine during normal operation

Your boat is equipped with an engine emergency safety cut-out switch. The switch is located on the console, below the shift/throttle control. The switch incorporates a shut-off switch, switch clip, lanyard and lanyard clip, which is clipped to the operator when running.

If an emergency arises and the engine must be shut down, a pull on the cord to release the clip from the shut-off will shut off the engine.

This switch is designed to shut the engine off when the operator of the boat leaves the control station, either accidentally by falling into the boat, or by being ejected overboard. This would most likely occur as a result of poor operating practices.

The lanyard should be long enough to prevent inadvertent activation. Do not let the lanyard become entangled.

Engine Stop Switch

Fig. 1.17.1

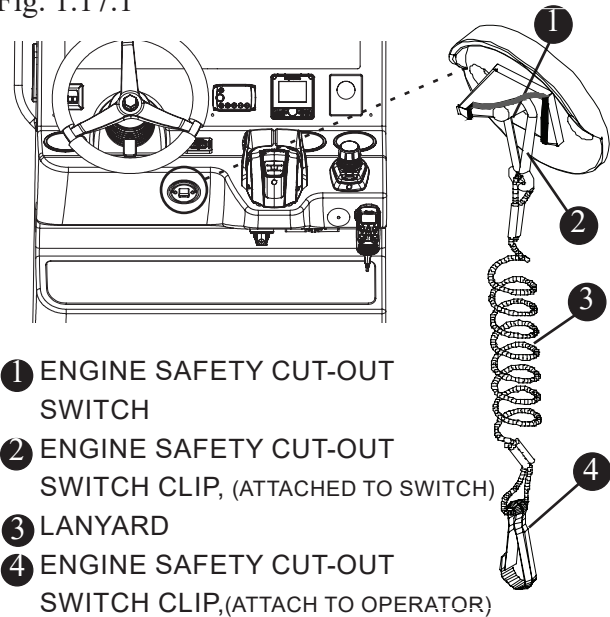

NOTICE

This switch only works when used properly. The decision of whether to use an ignition safety switch or not rests with you, the operator.

Accidental loss of power can be hazardous, particularly while docking or in heavy seas, strong current or high winds. Passengers and crew may lose balance and the boat may lose steering control.

Should the operator fall out of the boat at planing speed, it may take several seconds for the engine and propeller to stop turning. The boat may continue to coast for several hundred feet, causing injury to anyone in its path.

1st Mate™ Safety and Security System

The 1st Mate mobile app and wearable device integrate with Mercury systems to provide alerts, alarms, and distress communications designed to keep the captain and passengers safe. The system accommodates a captain and up to seven passengers. Features includes:

- Captain overboard event turns engine(s) off.
- Captain or passenger overboard event sounds alarm on the boat and via the app.

- Distress message capabilities to alert emergency contact(s) including location, heading, date and time of incident.
- Theft deterrent against boat-and-engine theft.

REFER TO OWNER'S PACKET FOR COMPLETE INSTRUCTIONS AND WARRANTY INFORMATION.

Float Plan

Float plans are important to you should you encounter problems on the water. A float plan should describe where you will be boating, departure time and return, number and names of passengers and destination.

The float plan should be given to a friend or relative, so they can give the information to a national boating agency like the U.S. Coast Guard, in the event you do not return at the time specified on the float plan.

If there are any changes to the float plan they should be conveyed to the person holding the float plan. Once you return you should contact the person holding the float plan to let them know you are back.

Chart Your Course

To avoid boating in unsafe areas where there are underwater obstructions, shallow water, unnavigable conditions such as dangerous currents, and others, you must chart a course. This means having and using National Oceanic and Atmospheric Administration (NOAA) charts for coastal waters, observing and understanding all navigational aids, using the knowledge and guidance of experienced boaters, and being aware of the tides and times where appropriate. If you are boating in an area you are unfamiliar with, proceed with caution and post a lookout to watch for hazards.

WARNING

Hitting an object in or under the water or boating in dangerous currents can cause serious injury or death to occupants in the boat.

You must know where the hazards are and avoid them. In uncharted waters, boat very slowly and post a lookout.

If an object is struck or if you run aground:

- **Shut the engine OFF**
- **Check the hull for damage**
- **Check propeller for damage**
- **If aground, consider the bottom grade before moving off, (damage to the hull and propellers could be worsened).**
- **Determine the tides and whether it will help or hinder you from the grounding.**
- **Do not have anyone other than a trained and competent service tow your boat.**

Environmental Considerations

Fuel & Oil Spillage

Regulations prohibit discharging fuel or oily waste in navigable waters. Discharge is defined as any action which causes a film, sheen or discoloration on the water surface, or causes a sludge or emulsion beneath the water surface. A common violation is bilge discharge. Use rags or sponges to soak up fuel or oily waste, then dispose of it properly ashore. If there is much fuel or oil in the bilge, contact a knowledgeable marine service to remove it. Never pump contaminated bilge overboard. Help protect your waters.

Excessive Noise

Many areas regulate noise limits. Even if there are no laws, courtesy demands that boats operate quietly.

Wake/Wash

Power boat wakes can endanger people and vessels. Each power boat operator is responsible for injury or damage caused by the boat's wake. Be especially careful in confined areas such as channels or marinas. Observe "no wake" warnings.

WARNING

SPEED HAZARD - Watch your wake. It might capsize a smaller craft. You are responsible for damage caused by your wake.

CAUTION

Reduce speed in congested waterway. Be alert for No Wake markers.

Homeland Security Restrictions

DANGER

DO NOT approach within 100 yards of any U.S. Naval vessel without first contacting the vessel on VHF-FM channel 16. To do so will result in a quick and severe response.

Recreational boaters have a role in keeping our waterways safe and secure. Violators of the restrictions below can expect a quick and severe response.

- Do not approach within 100 yards, and slow to minimum speed within 500 yards of any U.S. Naval vessel. If you need to pass within 100 yards of a U.S. Naval vessel for safe passage, you must contact the U.S. Naval vessel or the Coast Guard escort vessel on VHF-FM channel 16.

- Observe and avoid all security zones. Avoid commercial port areas, especially those that involve military, cruise line or petroleum facilities. Observe and avoid other restricted areas near dams, power plants, etc.
- **Do not** stop or anchor beneath bridges or in channels.

America's Waterway Watch

In March, 2005, the U.S. Coast Guard officially launched *America's Waterway Watch* to encourage the boating public to report suspicious activities in our nation's ports and waterways. *America's Waterway Watch* simply asks anyone who works, lives, or recreates on the water to keep an eye out for suspicious activities. Anyone who spots such activity is asked to call the National Response Center's 24-hour hot line, 800-424-8802 or 877-24WATCH (877-249-2824).

Warning Label Locations

Mounted at key locations throughout the boat, warning labels advise the owner/operator of imperative safety precautions to follow when operating and/or servicing equipment. Do not remove or obstruct any warning label. Replace any label which becomes illegible.

Warning Label Locations

Warning Label Locations
Fig. 1.20.1

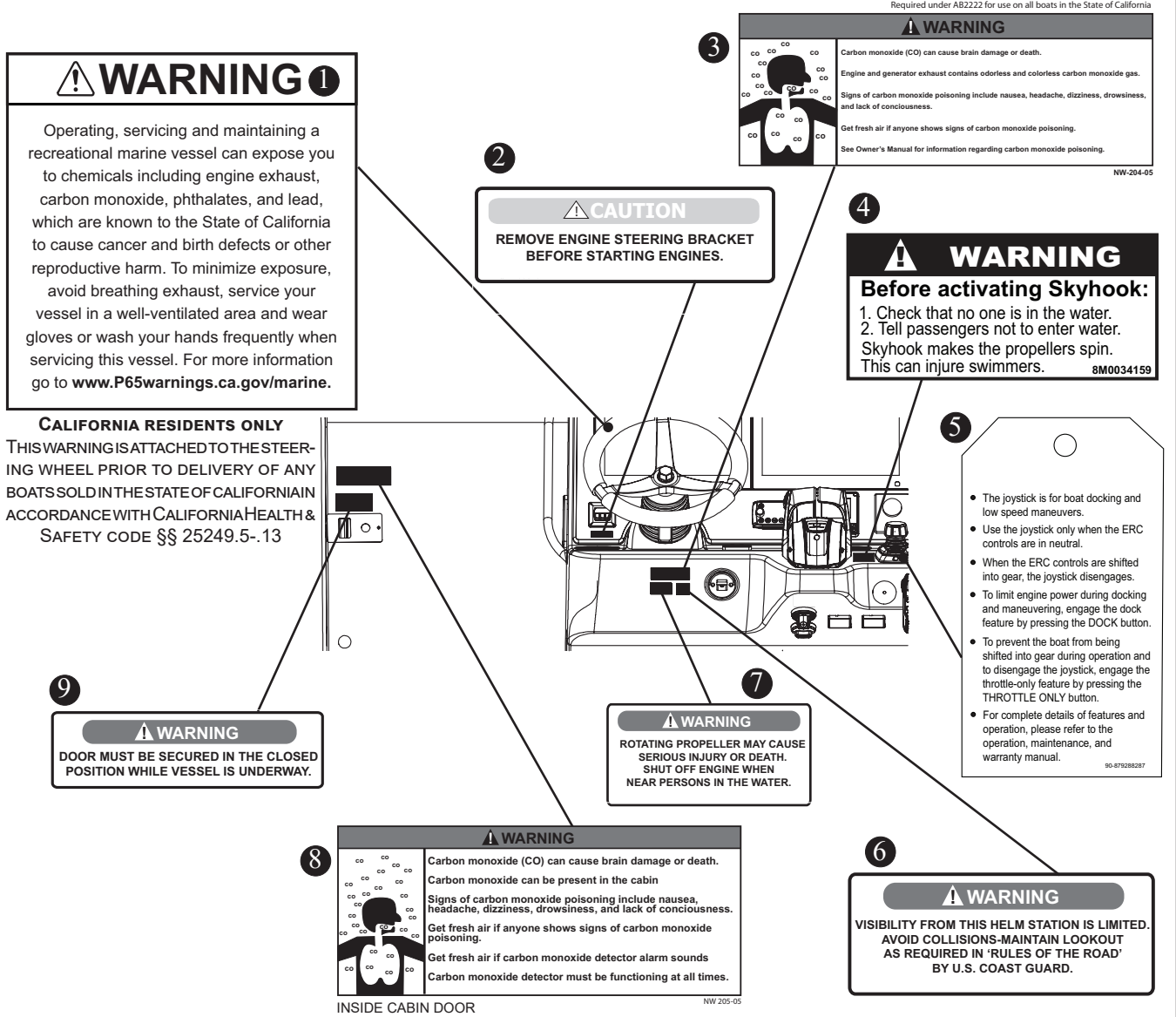

Replacement Part No.

1	PROP 65 HANG TAG.....	1795087
2	CAUTION, REMOVE STEERING BRACKET.....	2166526
3	DANGER, CO HELM.....	1811368
4	WARNING W/JOYSTICK LABEL KIT (OPTION).....	2238909
5	HANG TAG W/JOYSTICK LABEL KIT (OPTION).....	2238909
6	WARNING, LIMITED VISIBILITY FROM HELM.....	1752856
7	WARNING, ROTATING PROPELLER.....	1950698
8	WARNING, CO CABIN.....	1812911
9	WARNING, DOOR SECURED CLOSED.....	2063402

NOTICE

It is important to replace any damaged or unreadable label. Call your Boston Whaler dealer for replacement labels.

Warning Label Locations

Warning Label Locations
Fig.1.21.1

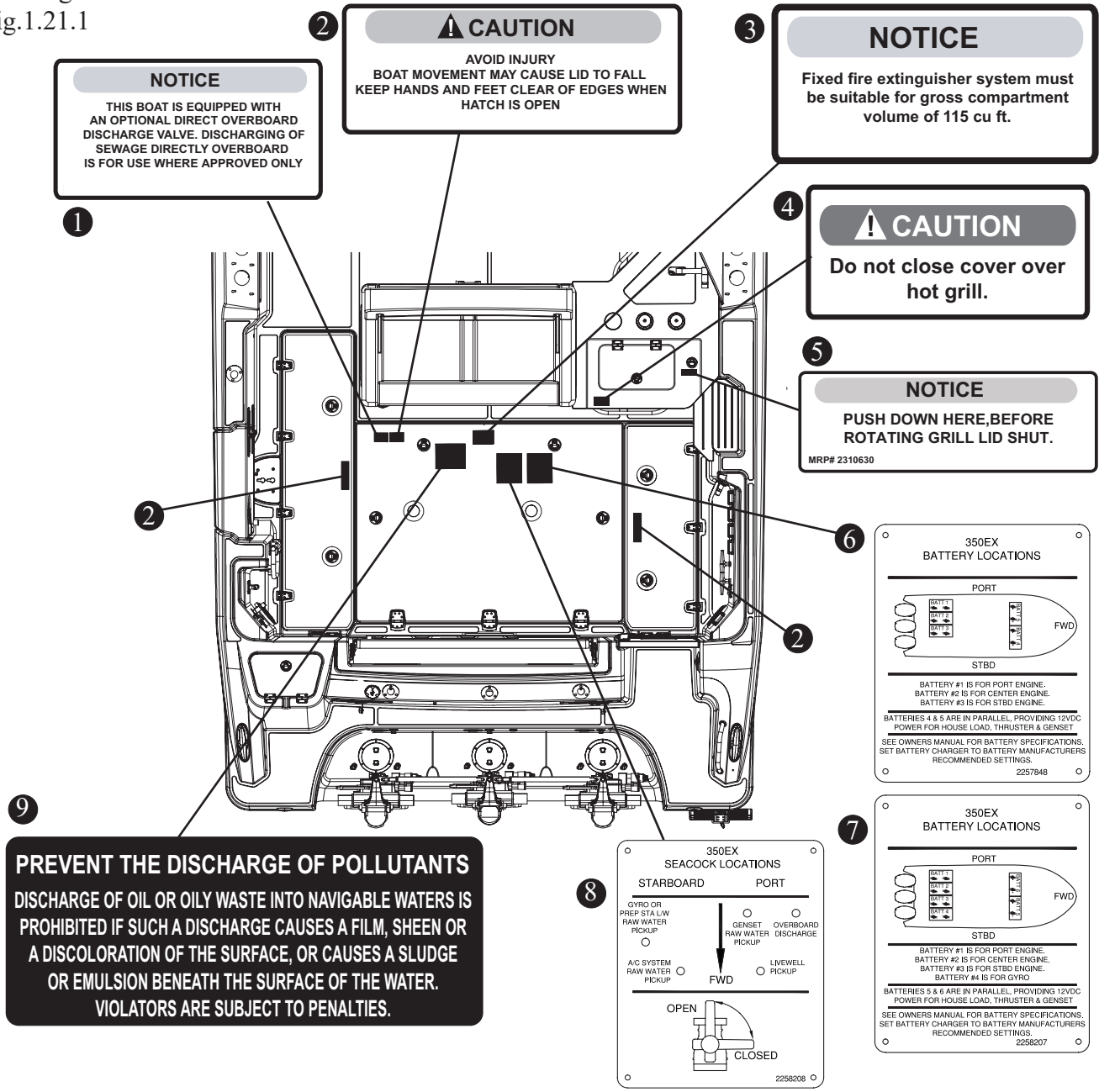

PREVENT THE DISCHARGE OF POLLUTANTS
DISCHARGE OF OIL OR OILY WASTE INTO NAVIGABLE WATERS IS PROHIBITED IF SUCH A DISCHARGE CAUSES A FILM, SHEEN OR A DISCOLORATION OF THE SURFACE, OR CAUSES A SLUDGE OR EMULSION BENEATH THE SURFACE OF THE WATER. VIOLATORS ARE SUBJECT TO PENALTIES.

Replacement Part No.

1	NOTICE, OVERBOARD DISCHARGE.....	2063413
2	CAUTION, AVOID INJURY, BOAT MOVEMENT	1836858
3	NOTICE, BILGE VOLUME	2066100
4	CAUTION, GRILL COVER	2120586
5	NOTICE, GRILL COVER.....	2310630
6	BATTERY LOCATION PLATE.....	2257848
7	GYRO BATTERY LOCATION PLATE (OPTION)	2258207
8	SEACOCK LOCATIONS PLATE.....	2258208
9	DISCHARGE OF OIL.....	2063375

NOTICE
It is important to replace any damaged or unreadable label. Call your Boston Whaler dealer for replacement labels.

Warning Label Locations (Cont'd)
Fig.1.22.1

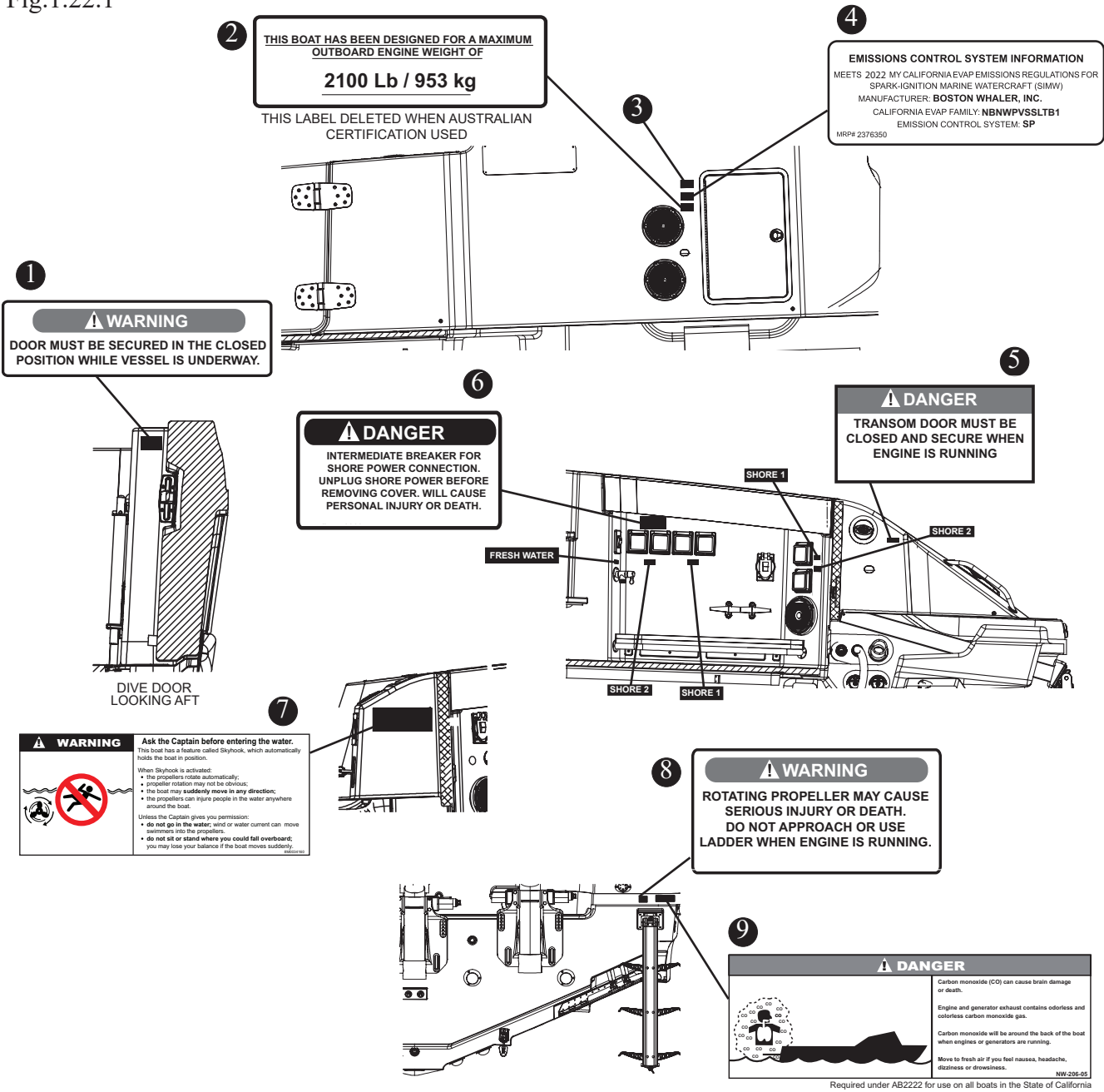

Replacement Part No.

1	WARNING, SECURE DOOR	2063402
2	MAXIMUM ENGINE WEIGHT.....	1851949
3	VESSEL CERTIFICATION/CAPACITY	SEE FIGURE 2.2.1
4	CARB EVAP EMISSIONS	2376350
5	DANGER, TRANSOM DOOR SECURE	2063385
6	WARNING, INTERMEDIATE BREAKER	2029122
7	WARNING W/JOYSTICK LABEL KIT (OPTION)	2238909
8	WARNING, ROTATING PROPELLER TRANSOM.....	1903624
9	DANGER, CO TRANSOM.....	1811367

NOTICE
It is important to replace any damaged or unreadable label. Call your Boston Whaler dealer for replacement labels.

Warning Label Locations (Cont'd)

Fig.1.23.1

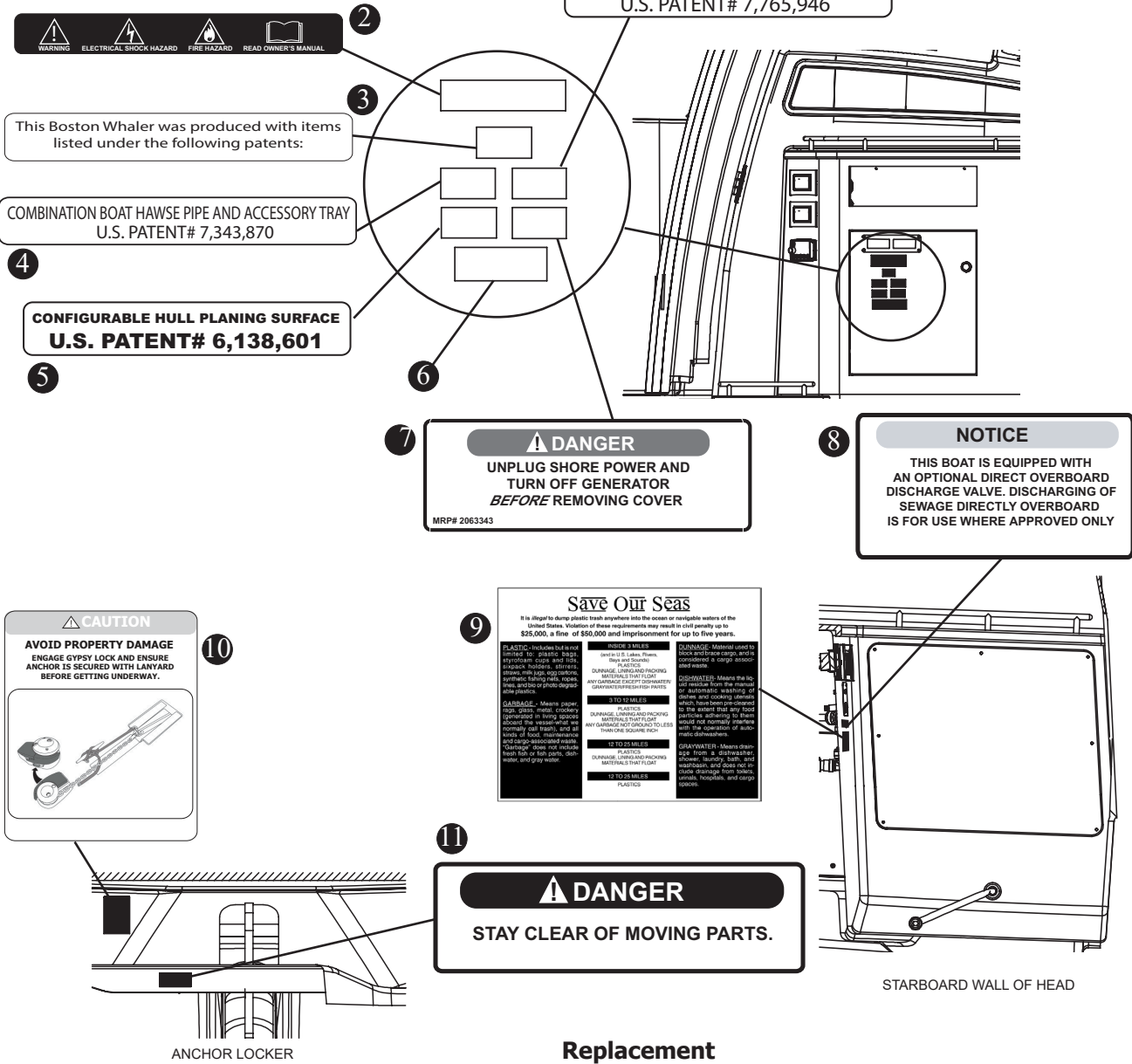

Replacement Part No.

1	PATENT, BOW THRUSTER.....	2063996
2	WARNING, AC PANEL.....	2025598
3	PATENT NOTICE.....	2088481
4	PATENT, HAWSE PIPE/DRINK HOLDER.....	2063995
5	PATENT, CONFIG HULL.....	2175365
6	DANGER, RUN BLOWER (CANADA OPTION).....	2175075
7	WARNING, UNPLUG SHORE POWER.....	2063343
8	NOTICE, OVERBOARD DISCHARGE.....	2063381
9	SOS, DISPOSAL OF GARBAGE.....	2029125
10	CAUTION, SECURE ANCHOR.....	2147835
11	DANGER, STAY CLEAR OF MOVING PARTS.....	2028932

NOTICE
It is important to replace any damaged or unreadable label. Call your Boston Whaler dealer for replacement labels.

Warning Label Locations (Cont'd)

Fig.1.24.1

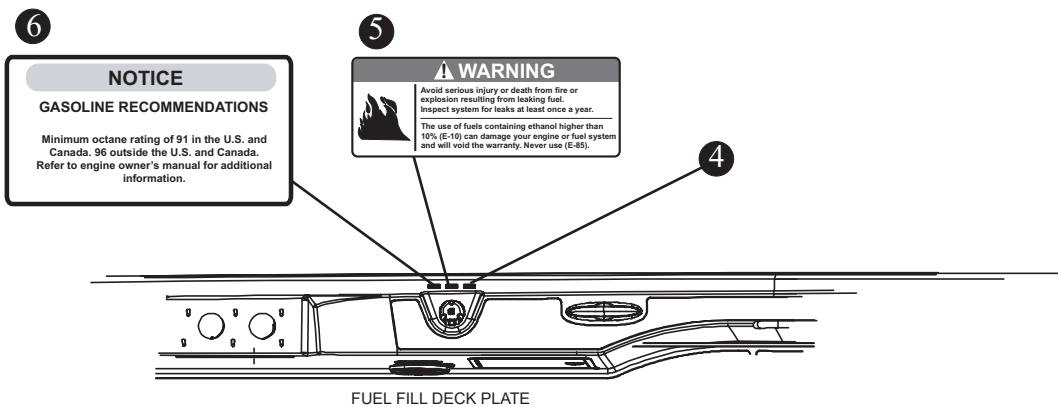
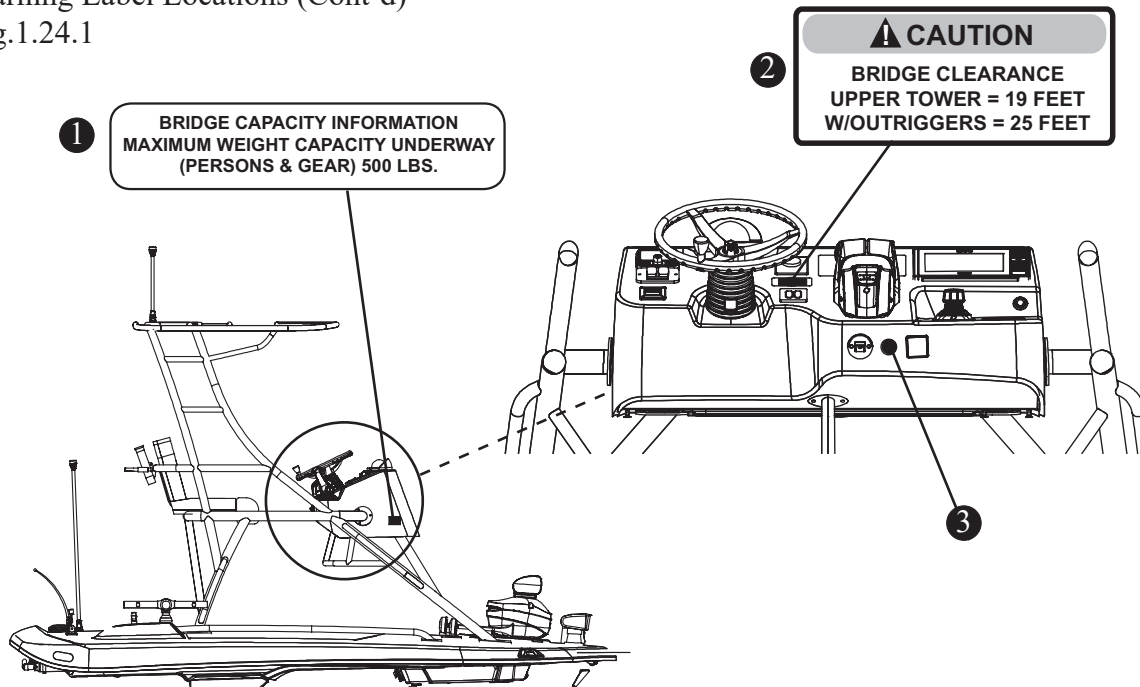

FUEL FILL DECK PLATE

Replacement Part No.

1	LABEL, BRIDGE CAPACITY 500 LB / 227 KG	2174751
2	CAUTION, BRIDGE CLEARANCE	2174750
3	DECAL WEAR YOUR LANYARD	2156485
4	WARNING, LEAKING FUEL (CANADA OPTION)	2175077
5	WARNING FUEL HAZARD	2096004
6	NOTICE, RECOMMENDED FUEL	2038447

NOTICE

It is important to replace any damaged or unreadable label. Call your Boston Whaler dealer for replacement labels.

Key to Symbols on Controls

Although not used in this manual, some of these symbols may be found on the controls, gauges, and hardware on your boat. This page is to help you understand what the symbols mean.

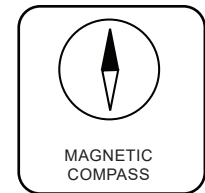
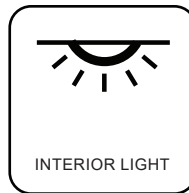
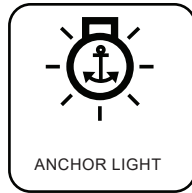
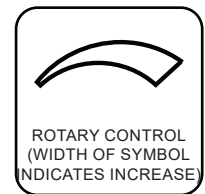
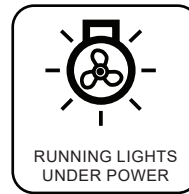
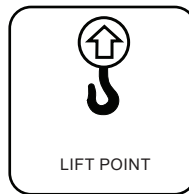
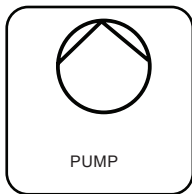
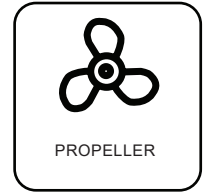
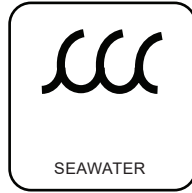
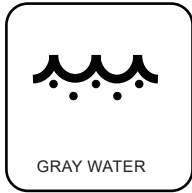
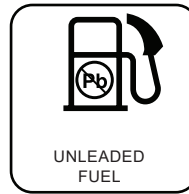
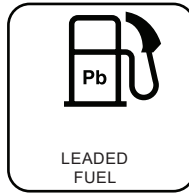
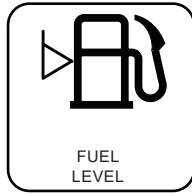
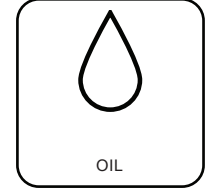
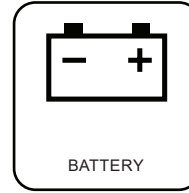
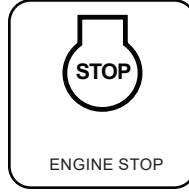
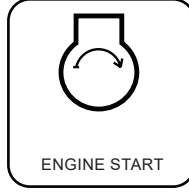
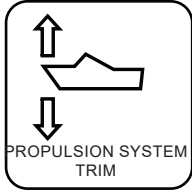

THIS PAGE INTENTIONALLY LEFT BLANK

Construction Standards

Boston Whaler® is dedicated to creating a superior product which will provide comfort, performance, safety and dependability. All of our boats comply with the safety standards set by the United States Coast Guard and are designed, engineered and manufactured in accordance with applicable recommendations and guidelines of the American Boat and Yacht Council (A.B.Y.C.) and certified by the National Marine Manufacturers Association (N.M.M.A.).

Our Hull

Boston Whaler® hulls are constructed with our patented Unibond™ construction process. This involves foam injection into a closed mold system where the foam expands to fill all voids in the hull. When the finished product is pulled from the mold, the hull and deck are chemically bonded to form a solid, inseparable unit.

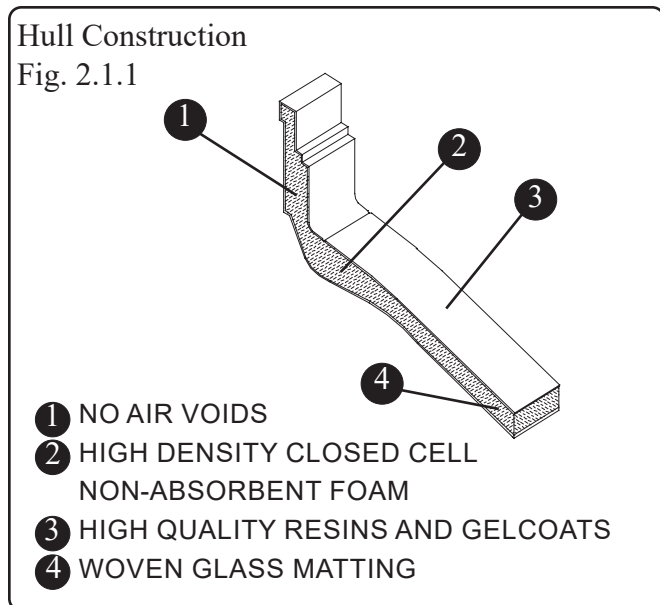

Hull Identification Number

The “Hull Identification Number” is located on the starboard side of the transom.

This is the most important identifying factor and must be included in all correspondence related to your vessel. Also of vital importance are the engine serial numbers, part numbers, etc. when writing about or ordering parts for your engine.

Hull Identification Number (HIN)

Fig. 2.1.2

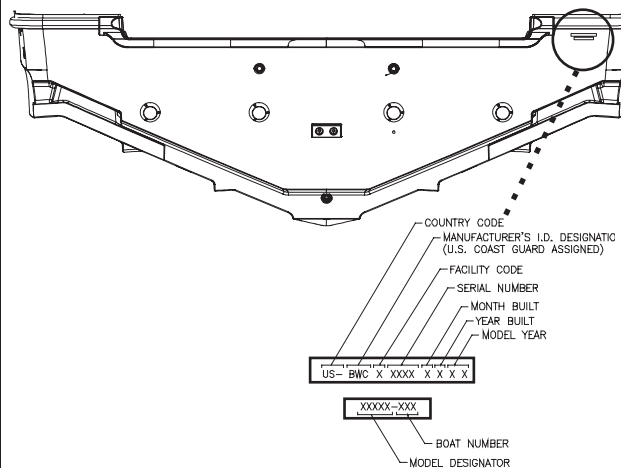

Record your HIN here:

Servicing Your Boston Whaler

When your Whaler requires service or maintenance work, it should be taken to an authorized Boston Whaler® dealer.

To find a Boston Whaler® dealer in your area call: **1-800-942-5379** (Domestic/International).

In the unlikely event that a problem is not handled to your satisfaction, discuss any warranty related problems directly with the service manager of the dealership or your sales person. Give the dealership an opportunity to help the service department resolve the matter for you.

Manufacturer's Certification

All boats must comply with federal regulations regarding maximum capacities. The certification plate (See figure 2.2.1) located on the port gunwale opposite the operator's console indicates certification by the National Marine Manufacturer's Association and in the case of international certification the sticker or plate indicates the maximum weight, number of persons, and horsepower your boat is rated to handle.

Section 2 • General Information

Certification Plates

Fig. 2.2.1



Replacement Part No. 0125062

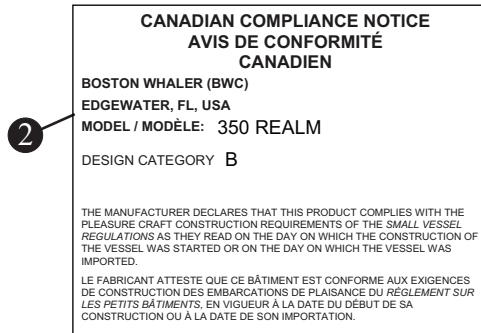

Replacement Part No. 2257843

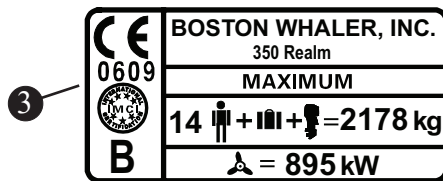

Replacement Part No. 2339799



Replacement Part No. 2339800

- 1 NMMA CERTIFICATE
- 2 CANADA CONFORMITY STICKER
- 3 CE MARK (INT'L) BUILDER'S PLATE
- 4 AUSTRALIAN BUILDER'S PLATE

The number of persons on board must be reduced if you go out in poor weather and rough water.

The information present on the certification plate does not relieve the operator from responsibility. Use common sense and sound judgement when placing equipment and/or passengers in your boat.

- Do not load to capacity in poor weather or rough water.
- The number of seats does not indicate how many people a boat can carry, especially in poor weather and rough water.
- Above idle speed, all passengers must be seated on the seats provided.

An **NMMA Certification** means that your Boston Whaler® has been judged by the National Marine Manufacturers Association to be in compliance with applicable federal regulations and American Boat and Yacht Council standards.

A **Canada Conformity Sticker** means that your Boston Whaler® has been certified to comply with construction standards for small vessels by Transport Canada.

A **CE mark** means that your Boston Whaler® has been certified with applicable International Organization for Standardization directives.

An **Australian Builder's Plate** means that your Boston Whaler® has been certified with safety standards set by the National Marine Safety Committee.

⚠ DANGER

NEVER carry more weight or passengers than indicated on the certification plate, regardless of the weather or water conditions.

Section 2 • General Information

CE Certification Design Category

A: A recreational craft given design category A is considered to be designed for winds that may exceed wind force 8 (Beaufort scale) and significant wave heights of 4 meters and above but excluding abnormal conditions, such as storm, violent storm, hurricane, tornado and extreme sea conditions or rogue waves.

B: A recreational craft given design category B is considered to be designed for a wind force up to, and including, 8 and significant wave heights up to, and including 4 m.

C: A watercraft given design category C is considered to be designed a wind force up to, and including 6 and significant wave heights up to, and including, 2 m.

D: A watercraft given design category D is considered to be designed for a wind force up to, and including 4 and significant wave heights up to, and including, 0,3 m, with occasional waves of 0,5 m maximum height.

The significant wave height is considered to be the primary factor for determining design category. Other parameters (e.g. meteorological) are descriptions of when these wave heights may be expected to occur. Refer to page 1-11 for weather information.

NOTICE

The 350 Realm is category B

Power Capacity

The certification plate, as well as “Specifications & Dimensions” on the following page has the maximum rated power listed for your boat. **DO NOT EXCEED THIS RATING.** The various engine types offered today are more powerful and require constant maintenance to stay at optimal performance. It is required of the owner/operator

to read all information regarding safety features, warning notices and maintenance schedules for continued safe operation of the engine.

The engines on your boat have been tested and proven to be best suited for general use under normal conditions and load.

If you are re-powering your Boston Whaler®, you should pay particular attention to the maximum/minimum horsepower and maximum safe engine weight load for which your boat is rated.

NOTICE

The 350 Realm is designed for a maximum outboard engine weight of 2100 LBS (953 kg).

NOTICE

Always adjust the speed and direction of the craft to the varying sea conditions.

WARNING

DO NOT Exceed the maximum engine power rating for your boat.

Use caution while accelerating. Make sure passengers are safely seated in designated areas of the boat and all gear is stowed securely.

Section 2 • General Information

Dimensions & Clearances

Fig. 2.4.1

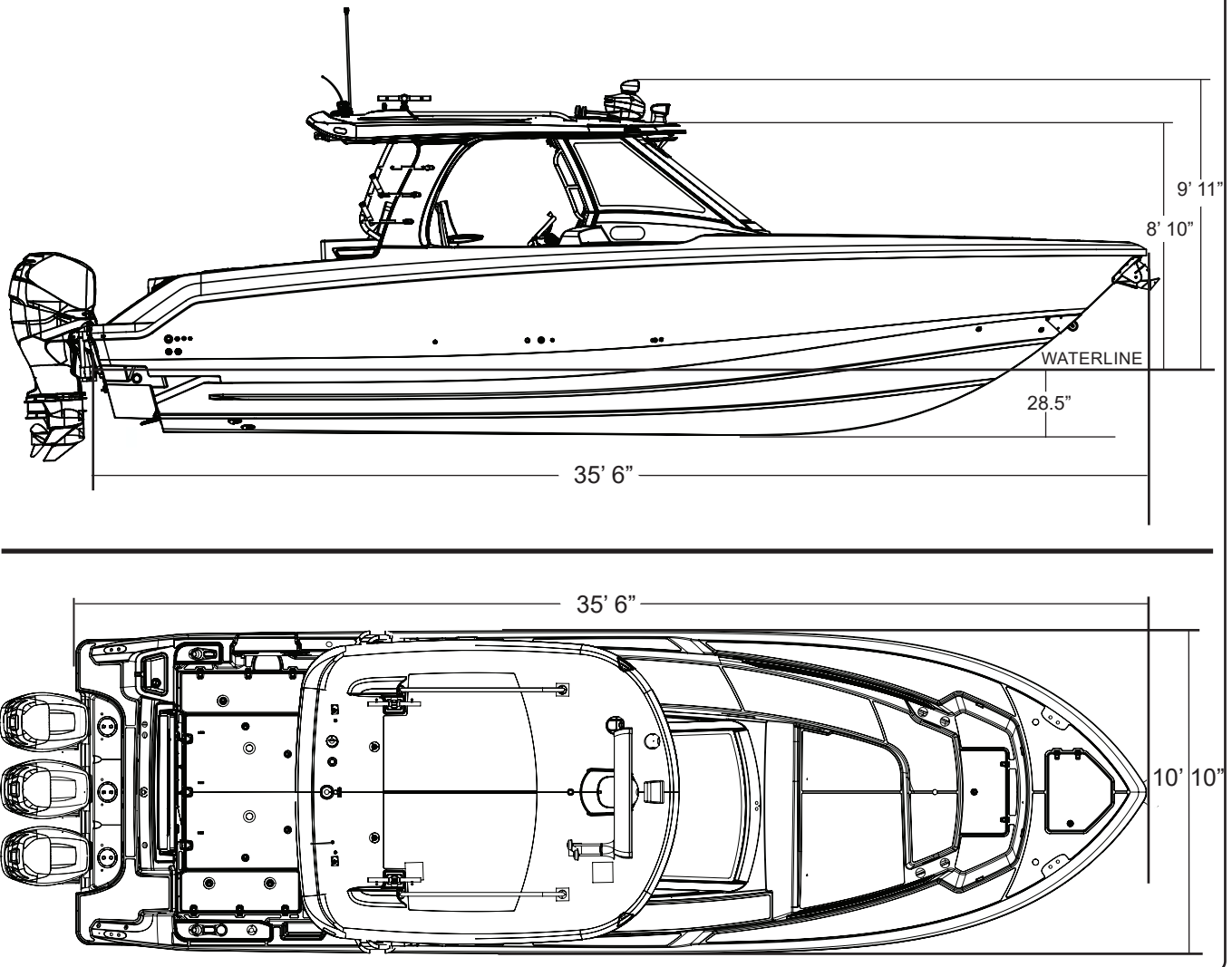

Specifications & Dimensions

(Specified measurements are approximations and are subject to variance.)

Overall Length	35' 6"	10.82 m	Maximum Engine Weight	2,100 lbs.	953 kg
Bridge Clearance			Max. Weight Capacity	4,800 lbs	2177 kg
- with hardtop	8' 10"	2.70 m	Persons	14	
- with optional radar	9' 11"	3.02 m	Maximum Horsepower	1200 HP	895 kw
Beam	10'10"	3.30 m	Minimum Horsepower	750 HP	559 kw
Draft, (boat only ¹)	28.5"	0.72 m	Fuel Capacity:	385 gal.	1457 L
Weight (dry, no engine)	13,600 lbs.	6169 kg	Water Capacity	45 gal.	170.34 L
Weight (fuel, water, engine)	18,830 lbs.	8559 kg	Waste Capacity	10 gal.	26 L
Swamped Capacity	4,000 lbs	1814 kg			

¹ Optional equipment and loading of the boat will affect the draft measurements. Follow the recommendations regarding the maximum amount of weight your boat can safely carry.

² Exceeding this weight will affect the boat's performance. **DO NOT** Exceed the weight listed.

Passenger Areas

Deck Occupancy
Fig. 2.5.1

Working deck:

 This area is intended for occupation **ONLY** while mooring, anchoring, loading/unloading or when the boat is at rest.

Accommodation deck:

 Movement in this area should be done with extreme caution while the boat is underway. A sudden shift in boat direction can cause a loss of balance and lead to injury or death.

 Do Not stand or walk on this area while underway. Serious injury could result. If necessary, stand or walk only where non-skid is applied.

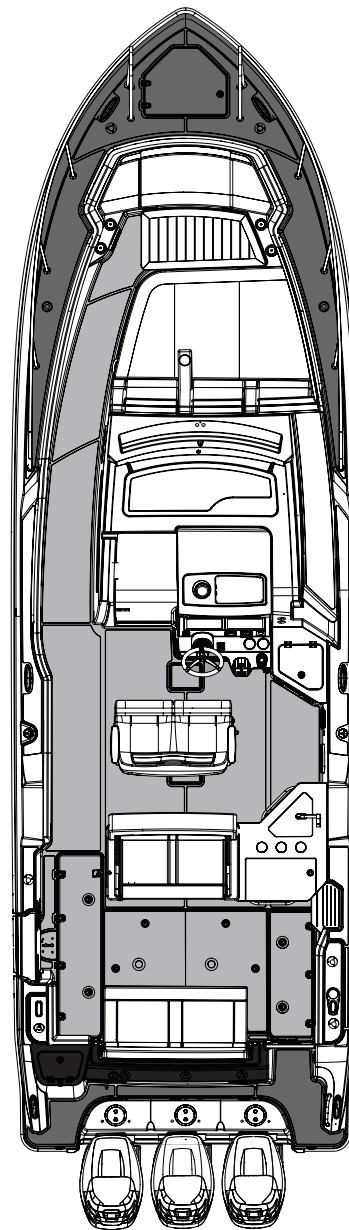
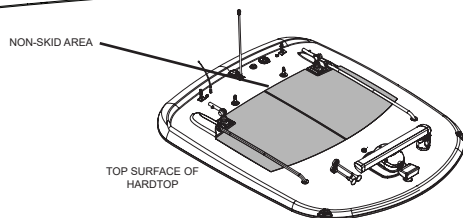
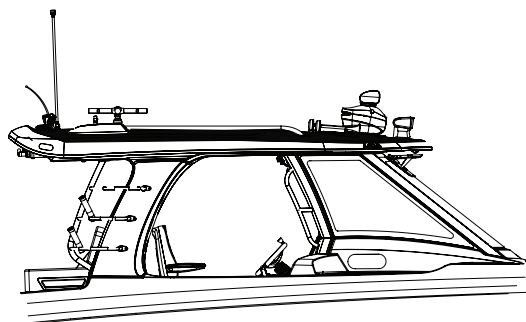

NOTE: Hardtop removed for clarity

⚠ WARNING

- Gelcoat surfaces are slippery when wet. Use extreme caution when walking on wet surfaces.
- Never occupy the working decks while the boat is underway.
- Use care when waxing to ensure that walkways are not made dangerously slippery.

⚠ DANGER

To avoid risk of injury or death, shut off engines when near swimmers or prior to using swim ladder.

⚠ DANGER

Be aware of your footing while the boat is underway, slipping or falling could result in serious injury or death, especially if the boat is in motion or in rough seas. Keep the accommodation deck clean, so if movement is necessary it will be free of obstruction.

Recommended Passenger Locations

Recommended Seating & On-Plane Locations
 Fig. 2.6.1

! WARNING
NEVER allow passengers to ride in an area (i.e. bow, gunnels, transom, etc. that will pose a hazard to themselves or the boat.

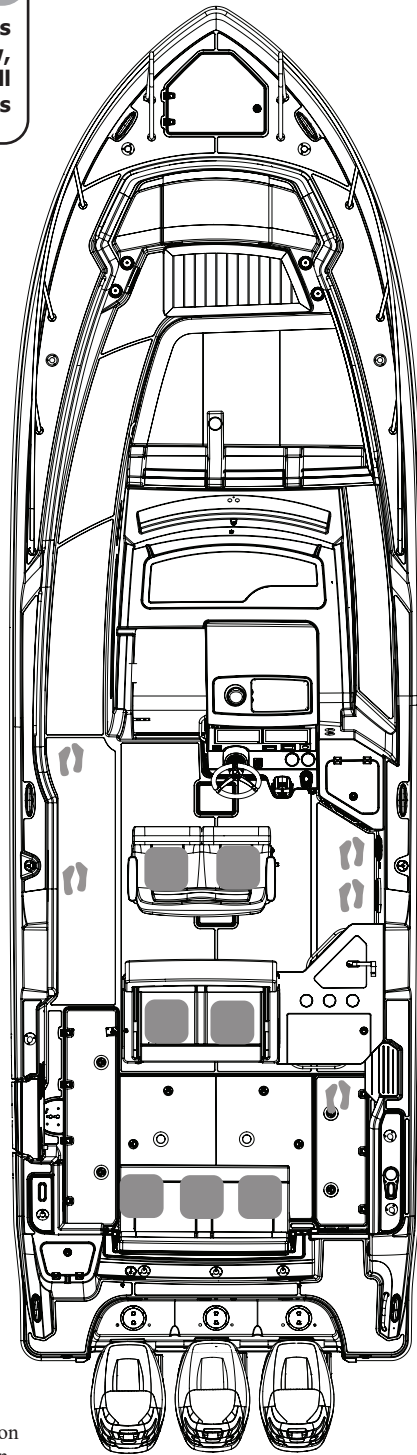
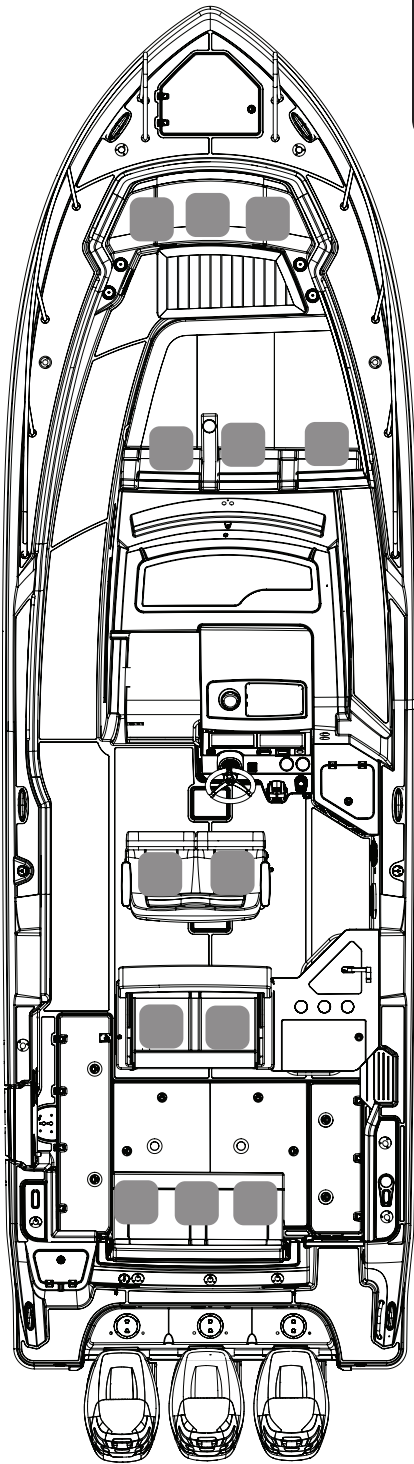

NOTES:
 1. Hardtop removed for clarity.
 2. Passenger locations not shown on deck are located inside the cabin.

RECOMMENDED SEATING
 while moored, at idle or at speed under 5 mph

RECOMMENDED ON-PLANE
 LOCATIONS

Location of Thru-Hull Fittings

Thru-Hull Fittings
Fig. 2.7.1

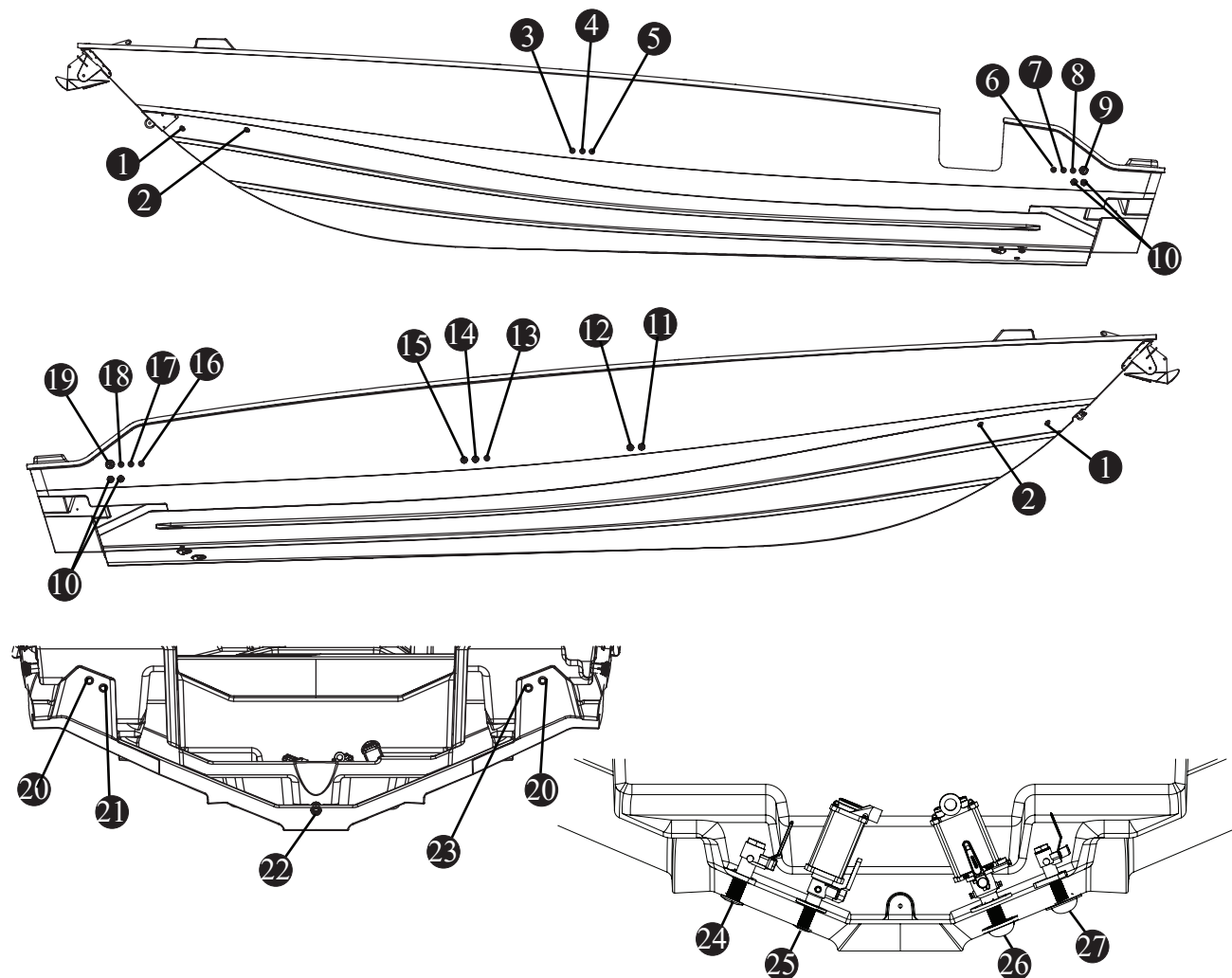

- | | |
|--|---|
| <ul style="list-style-type: none"> ① ANCHOR LOCKER DRAIN ② BOW STORAGE DRAIN ③ FORWARD BILGE DRAIN ④ SUMP BOX DRAIN ⑤ A/C DISCHARGE ⑥ GYROSCOPE STABILIZER DRAIN (OPTION) ⑦ HI LEVEL BILGE PUMP DISCHARGE ⑧ PORT FISH BOX PUMP OUT ⑨ AFT LIVEWELL DRAIN ⑩ DECK DRAINS ⑪ SINK DRAIN ⑫ HOT WATER PRESSURE RELEASE ⑬ HELM A/C DISCHARGE ⑭ PREP STATION SINK DRAIN & HELM ICE BUCKET DRAIN | <ul style="list-style-type: none"> ⑮ PREP STATION LIVEWELL DRAIN (OPTION) ⑯ FREEZER PLATE (OPTION) ⑰ BILGE PUMP DISCHARGE ⑱ STARBOARD FISH BOX PUMP OUT ⑲ GENERATOR EXHAUST OUTLET ⑳ WASTE SYSTEM VENT ㉑ HELM A/C CONDENSATE ㉒ GARBOARD DRAIN ㉓ PREP STATION TUB DRAIN ㉔ MACERATOR DISCHARGE ㉕ GENERATOR INTAKE ㉖ A/C INTAKE ㉗ PREP STATION LIVEWELL INTAKE (OPTION) & GYRO STABILIZER INTAKE (OPTION) |
|--|---|

NOTICE

- **The deck drains provide self-bailing capabilities while the boat is static in the water and no passengers on board. This feature prevents the accumulation of water in the cockpit.**
- **Depending on the type of boat you have, you may have underwater fittings that need drain plugs. Garboard drain plugs and fish box drain plugs need to be in place before the boat goes into the water. Any fitting that will be underwater needs to be plugged or the seacock needs to be closed.**
- **Through hull fittings and deck drain scupper flaps should be checked for proper seal annually. When the boat is in the water the underwater fittings can be checked for dripping. It is recommended that the underwater fittings be removed, cleaned and resealed every other year.**
- **If the through hull fittings need to be replaced, it is recommended that an authorized Boston Whaler® dealer perform this type of repair. Through hull fittings that are improperly installed can cause premature hull failure and may void the Boston Whaler® limited warranty.**
- **A standard 1" "Snap-Tite" plug can be used to replace the garboard drain plug in your boat. It is recommended that you carry spare plugs to be used in the event that the garboard drain plug becomes lost or damaged.**

Section 2 • General Information

General Layout

General Layout, Exterior (Hardtop removed for clarity)

Fig. 2.9.1

- ① STAINLESS STEEL BOW RAIL (OPTION)
- ② BOW PULL UP CLEATS (P&S)
- ③ BOW ROD HOLDERS (P&S)
- ④ INTEGRATED CUP HOLDERS (P&S)
- ⑤ BOW LOUNGE W/BACKREST & FOLD DOWN ARMRESTS
- ⑥ DECK MOUNTED ROD HOLDERS (P&S)
- ⑦ SKYLIGHT
- ⑧ MAGNETIC COMPASS
- ⑨ LOCKABLE ACRYLIC CABIN DOOR
- ⑩ DECK ACCESS
- ⑪ MID-SHIP SPRING LINE CLEATS (P&S)
- ⑫ DELUXE HELM SEAT W/ADJUSTABLE ELECTRIC SLIDE, 180 DEGREE ROTATION SEAT & TEAK FOOTREST
- ⑬ FUEL FILL
- ⑭ 2-PERSON SEAT W/CONVERSION SEAT BACK FOR FORWARD OR AFT FACING SEATING
- ⑮ DIVE DOOR FRESH WATER SHOWER
- ⑯ GUNWALE MOUNTED ROD HOLDERS (P&S)
- ⑰ PORT IN-DECK FISHBOX W/PUMP OUT
- ⑱ DIVE/BOARDING DOOR W/REMOVABLE LADDER
- ⑲ FOLD OUT STERN BENCH SEAT
- ⑳ PRESSURIZED, 15 GAL (56.78 L) LIVEWELL
- ㉑ PULL-UP CROSS TIE CLEAT (P&S)
- ㉒ WASTE PUMP OUT DECK PLATE
- ㉓ TRANSOM MOUNTED ROD HOLDERS (3)
- ㉔ MOTORWELL ACCESS PLATES
- ㉕ MERCURY 4-STROKE ENGINES WITH SHADOW MODE TECHNOLOGY*
- ㉖ RECESSED TELESCOPING DIVE LADDER
- ㉗ GRAB RAIL
- ㉘ TRANSOM FRESH WATER SHOWER
- ㉙ HAWSE PIPE W/AFT CLEAT UNDER
- ㉚ STARBOARD IN-DECK FISHBOX W/PUMP OUT
- ㉛ TEAK BOARDING STEPS
- ㉜ MECHANICAL EQUIPMENT HATCH
- ㉝ ELECTRIC GRILL W/POP-UP ROTATING COVER
- ㉞ FRESH WATER SINK
- ㉟ FRESH WATER FILL
- ㊱ STORAGE
- ㊲ CONSOLE
- ㊳ RECESSED STORAGE TRAY W/USB & 12V CHARGING RECEPTACLES

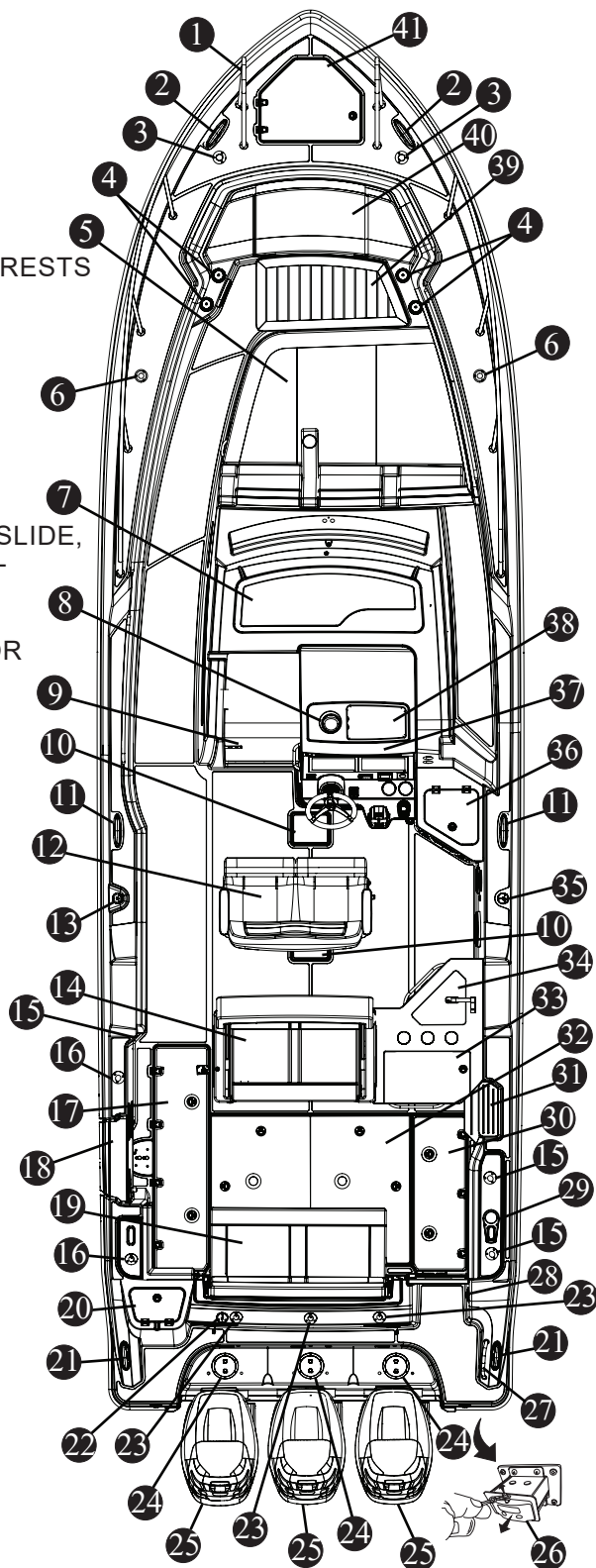

- ③⑨ ELECTRICALLY ACTUATED TEAK BOW TABLE/SUN LOUNGE W/ FILLER CUSHION
- ④⑩ BOW WRAP AROUND SEATING
- ④① ANCHOR LOCKER W/THRU HULL ANCHOR ROLLER

* 91 octane fuel recommended

Section 2 • General Information

General Layout, Bow Side Pockets
Fig 2.10.1

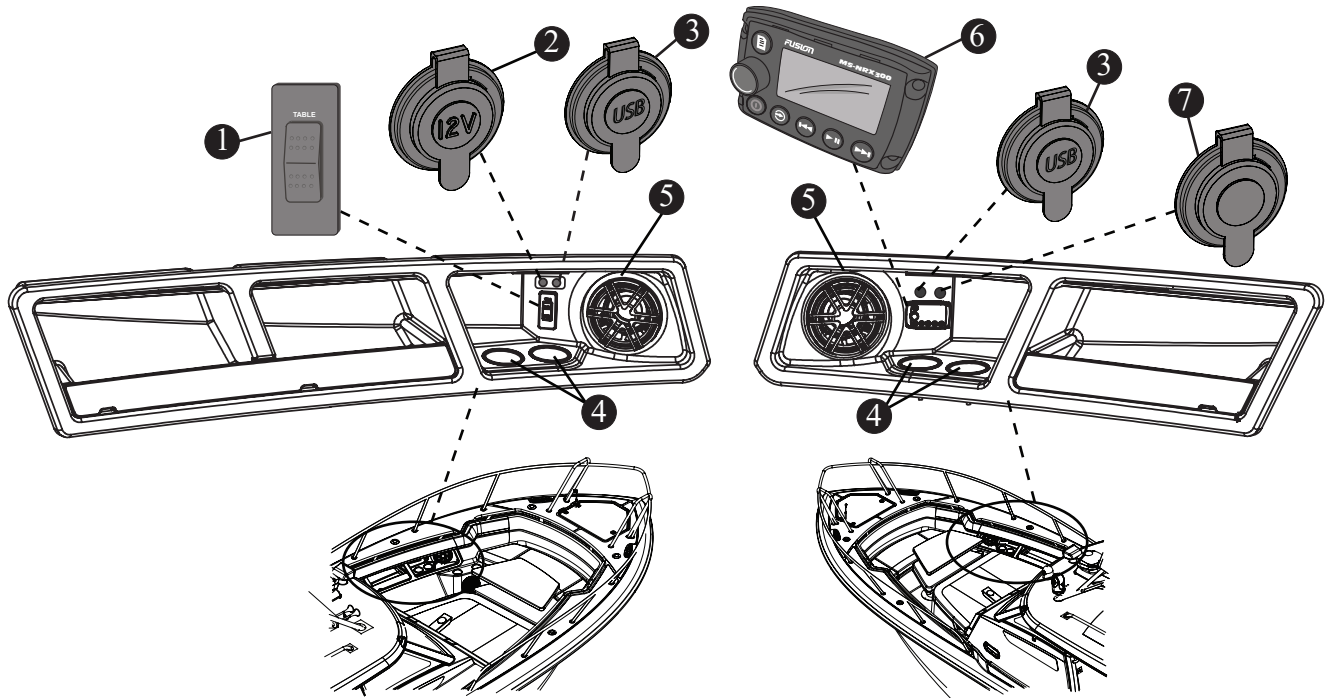

- | | |
|-----------------------------|----------------------|
| ① ELECTRIC BOW TABLE SWITCH | ⑤ WATERPROOF SPEAKER |
| ② 12V ACCESSORY RECEPTACLE | ⑥ STEREO REMOTE |
| ③ DUAL USB CHARGER | ⑦ USB/MP3 INPUT |
| ④ CUP HOLDERS | |

Section 2 • General Information

General Layout, Control Station

Fig. 2.11.1

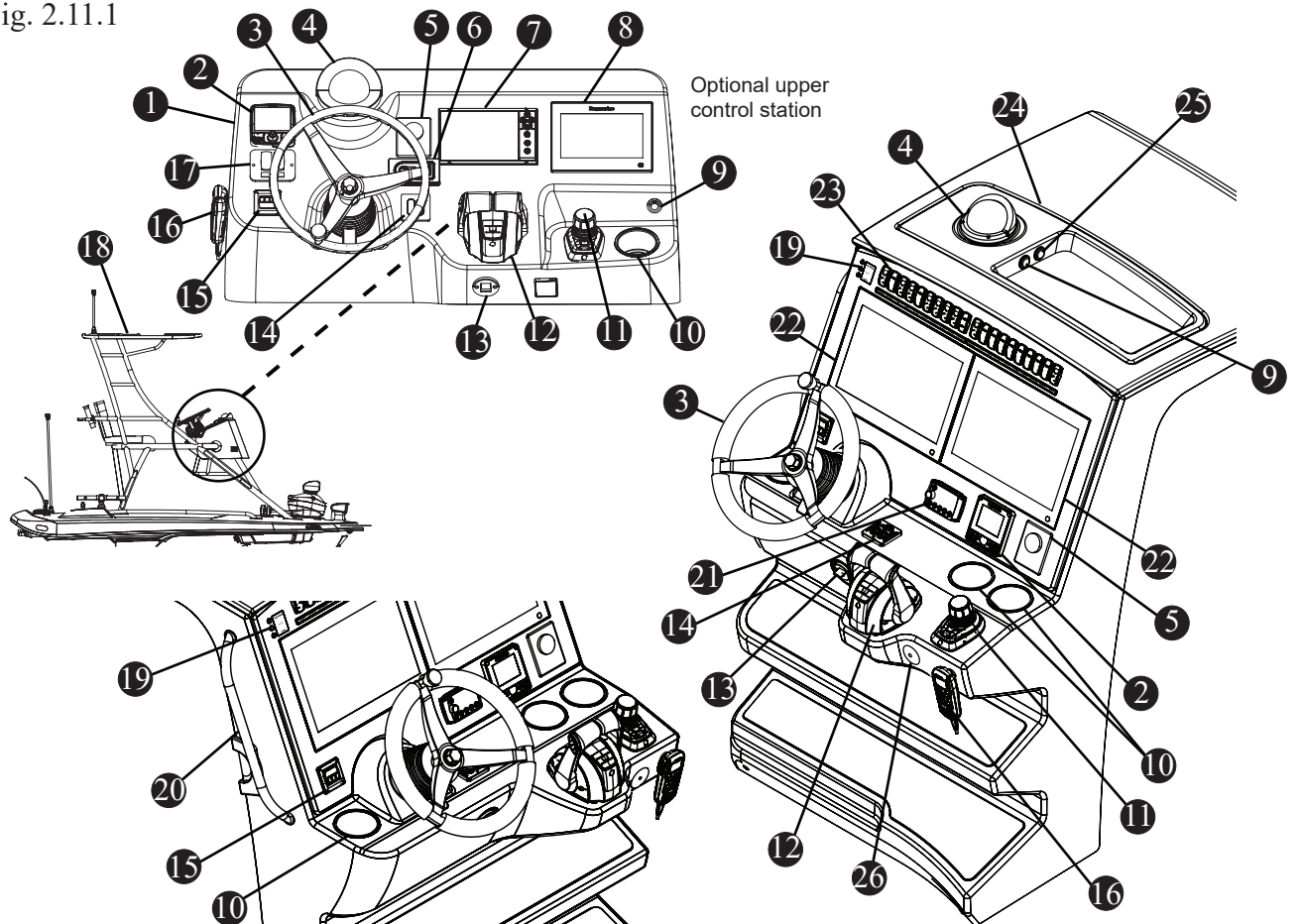

- | | |
|-----------------------------------|------------------------------------|
| ① UPPER CONSOLE (OPTION) | ⑱ UPPER CONTROL STATION (OPTION) |
| ② RAYMARINE AUTOPILOT | ⑲ BILGE PUMPS INDICATOR PANEL |
| ③ STAINLESS STEEL STEERING WHEEL | ⑳ GRAB RAIL |
| ④ MAGNETIC COMPASS | ㉑ STEREO REMOTE |
| ⑤ SPOTLIGHT REMOTE (OPTION) | ㉒ RAYMARINE 15.4\"/> |
| ⑥ ACTIVE TRIM PANEL (OPTION) | ㉓ HELM SWITCH PANEL |
| ⑦ VESSELVIEW | ㉔ RECESSED STORAGE TRAY |
| ⑧ RAYMARINE 9.5\"/> | ㉕ DUAL USB INPUT |
| ⑨ 12V ACCESSORY RECEPTACLE | ㉖ FIRE SUPPRESSION INDICATOR LIGHT |
| ⑩ CUP HOLDERS | |
| ⑪ JOYSTICK PILOTING (OPTION) | |
| ⑫ GEAR SHIFT/THROTTLE CONTROL | |
| ⑬ ENGINE SHUT DOWN SWITCH | |
| ⑭ TRIM TAB CONTROL PAD | |
| ⑮ ENGINES START/STOP SWITCH | |
| ⑯ VHF RADIO WITH WIRELESS HEADSET | |
| ⑰ HORN & OVERHEAD LIGHTS SWITCH | |

REFER TO THE MANUFACTURER'S MANUAL IN YOUR OWNER'S MANUAL PACKET FOR COMPLETE INSTRUCTIONS AND WARRANTY ON THE ELECTRONIC EQUIPMENT INSTALLED ON YOUR BOAT.

Section 2 • General Information

General Layout (Cont'd)

General layout, Bilge
Fig. 2.12.1

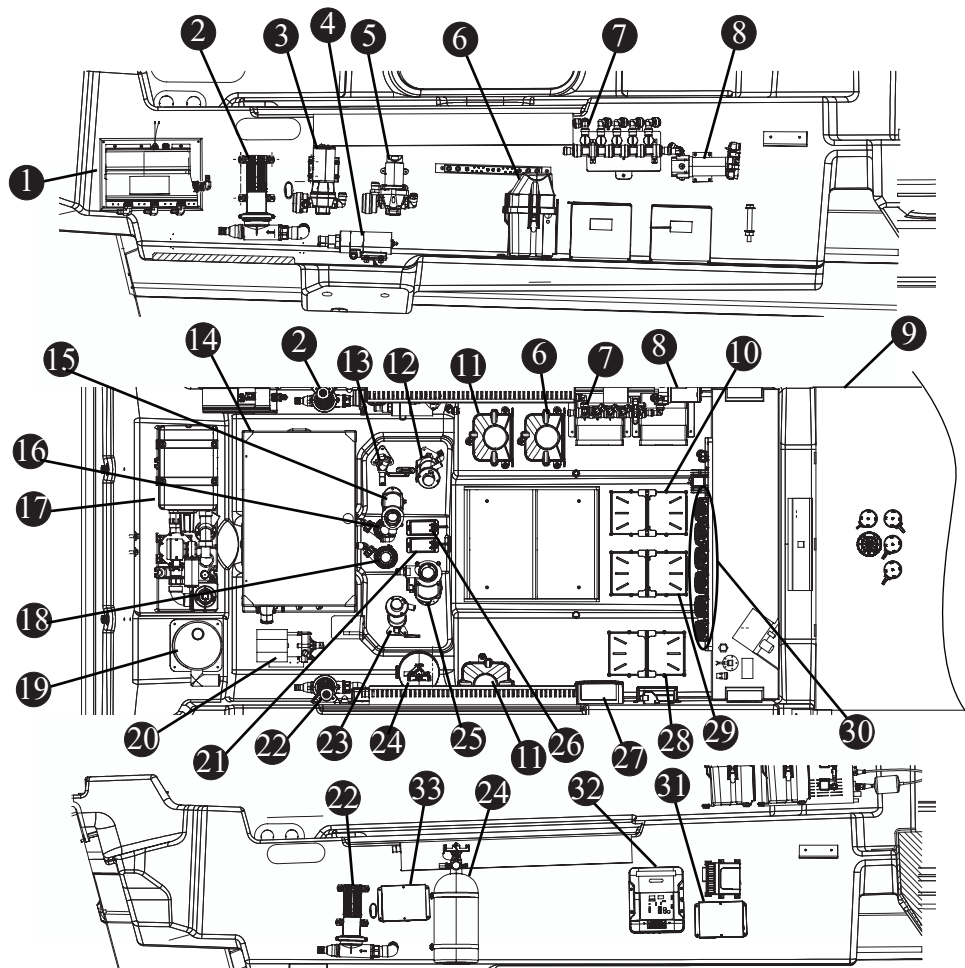

- | | |
|------------------------------------|---|
| ① ENGINE FLUSH PUMP (OPTION) | ⑱ GENERATOR MUFFLER |
| ② PORT FISH BOX PUMP OUT PUMP | ⑳ A/C PUMP |
| ③ RAW WATER WASHDOWN PUMP | ㉑ FLOAT SWITCH |
| ④ WASTE MACERATOR PUMP | ㉒ STARBOARD FISH BOX PUMP OUT PUMP |
| ⑤ FRESH WATER PUMP | ㉓ PREP STATION LIVEWELL INTAKE (OPTION) |
| ⑥ POWER STEERING PUMP | ㉔ GYROSCOPE STABILIZER INTAKE (OPTION) |
| ⑦ FRESHWATER DISTRIBUTION MANIFOLD | ㉕ AUTOMATIC FIXED FIRE EXTINGUISHER |
| ⑧ AUTOPILOT DRIVE UNIT (OPTION) | ㉖ A/C INTAKE |
| ⑨ 385 GAL (1,457 L) FUEL TANK | ㉗ EMERGENCY HIGH WATER FLOAT SWITCH |
| ⑩ PORT ENGINE BATTERY | ㉘ BATTERY CHARGER |
| ⑪ POWER STEERING PUMP (OPTION) | ㉙ STARBOARD ENGINE BATTERY |
| ⑫ AFT LIVEWELL INTAKE PUMP | ㉚ CENTER ENGINE BATTERY |
| ⑬ OVERBOARD WASTE DISCHARGE | ㉛ AUTOMATIC CHARGING RELAYS (ACR)/ |
| ⑭ GENERATOR | ㉜ BATTERY SWITCHES 60 GAL (227 L) FRESH |
| ⑮ GENERATOR INTAKE | ㉝ A/C COMPRESSOR PUMP RELAY |
| ⑯ BILGE PUMP (2000 GPH) | ㉞ BATTERY CHARGER |
| ⑰ 10 GAL (38 L) HOLDING TANK | ㉟ FREEZER CONDENSING RELAY (OPTION) |
| ⑱ HIGH WATER BILGE PUMP (2000 GPH) | |

Section 2 • General Information

General Layout (Cont'd)

General layout, Forward bilge
Fig. 2.13.1

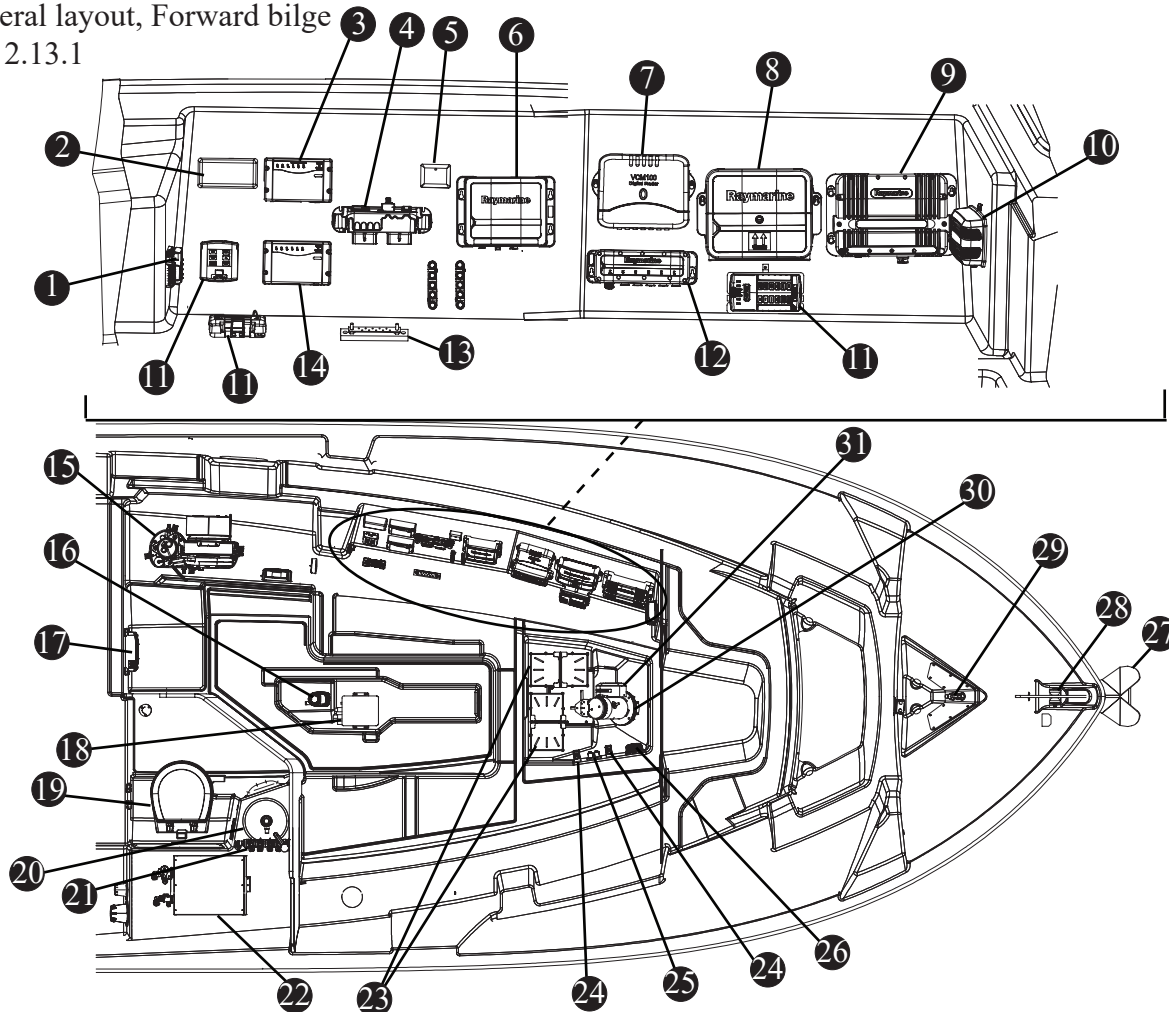

- | | |
|------------------------------------|------------------------------------|
| ① FUSE BLOCK | ①⑦ 10 GAL (38 L) HOLDING TANK |
| ② CZONE, AC TRANSDUCER | ①⑧ SHOWER SUMP |
| ③ CZONE SIGNAL INTERFACE | ①⑨ VACUFLUSH HEAD |
| ④ WIFI MODULE | ②① VANITY SINK |
| ⑤ REMOTE CZONE KEY FOB | ②② HOT WATER DISTRIBUTION MANIFOLD |
| ⑥ CHIRP DOWNVISION MODULE (OPTION) | ②③ WATER HEATER |
| ⑦ DIGITAL RADAR MODULE (OPTION) | ②④ FORWARD BATTERY TRAY |
| ⑧ AUTOPILOT MODULE | ②⑤ FUSE |
| ⑨ DEPTH SOUNDER MODULE | ②⑥ DC CURRENT SENSOR |
| ⑩ SIRIUSXM RECEIVER (OPTION) | ②⑦ BATTERY SWITCH |
| ⑪ FUSE BLOCK | ②⑧ ANCHOR |
| ⑫ RAYMARINE MODULE (OPTION) | ②⑨ ANCHOR ROLLER |
| ⑬ BUSS BAR | ②⑩ LIFTING EYE |
| ⑭ CZONE METER INTERFACE | ③① BOW THRUSTER |
| ⑮ A/C COMPRESSOR | ③② BATTERY CHARGER |
| ⑯ FORWARD BILGE PUMP (1100 GPH) | |

Section 2 • General Information

General Layout (Cont'd)

General Layout, Port Aft Cockpit
Fig. 2.14.1

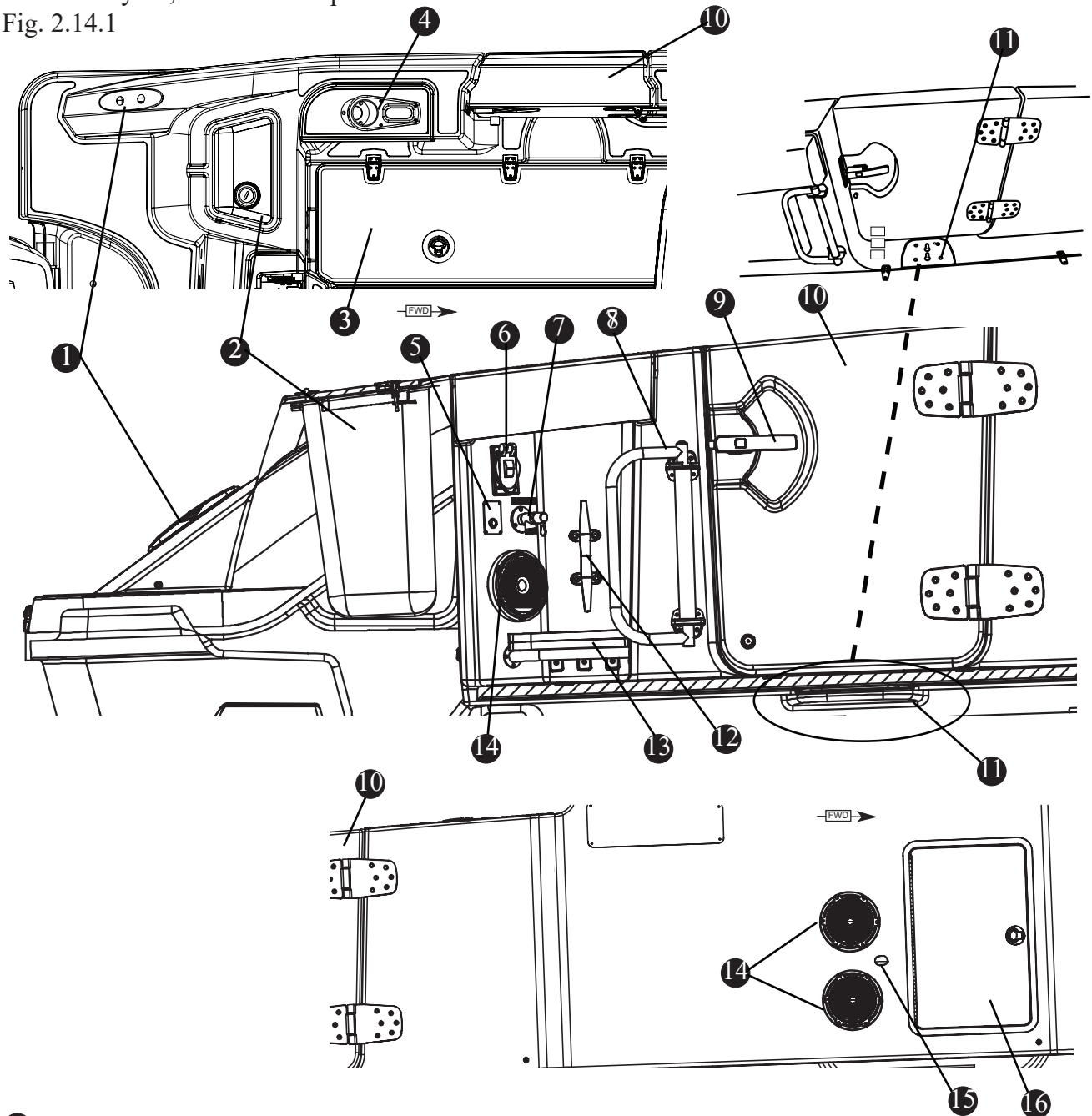

- | | |
|--|---------------------------------------|
| ① PULL-UP CROSS TIE CLEAT (P&S) | ⑨ STAINLESS STEEL LATCH |
| ② PRESSURIZED, 15 GAL (56.78 L) LIVEWELL | ⑩ DIVE/BOARDING DOOR |
| ③ INSULATED IN-DECK FISH BOX W/PUMP OUT | ⑪ DIVE LADDER BRACKET |
| ④ HAWSE PIPE W/AFT CLEAT UNDER (P&S) | ⑫ AFT CLEAT (P&S) |
| ⑤ ENGINE FLUSH SWITCH (OPTION) | ⑬ DOWNRIGGER WEIGHT HOLDERS (P&S) |
| ⑥ 12V/30AMP DC RECEPTACLE FOR ELECTRIC REELS AND/OR DOWNRIGGERS (P&S) (OPTION) | ⑭ WATERPROOF STEREO SPEAKER (P&S) |
| ⑦ RAW WATER WASHDOWN | ⑮ COURTESY LIGHT |
| ⑧ DEPLOYABLE GRAB RAIL FOR DIVE DOOR | ⑯ DC DISTRIBUTION PANEL/IGNITION KEYS |

General Layout (Cont'd)

General Layout, Starboard Aft Cockpit
Fig. 2.15.1

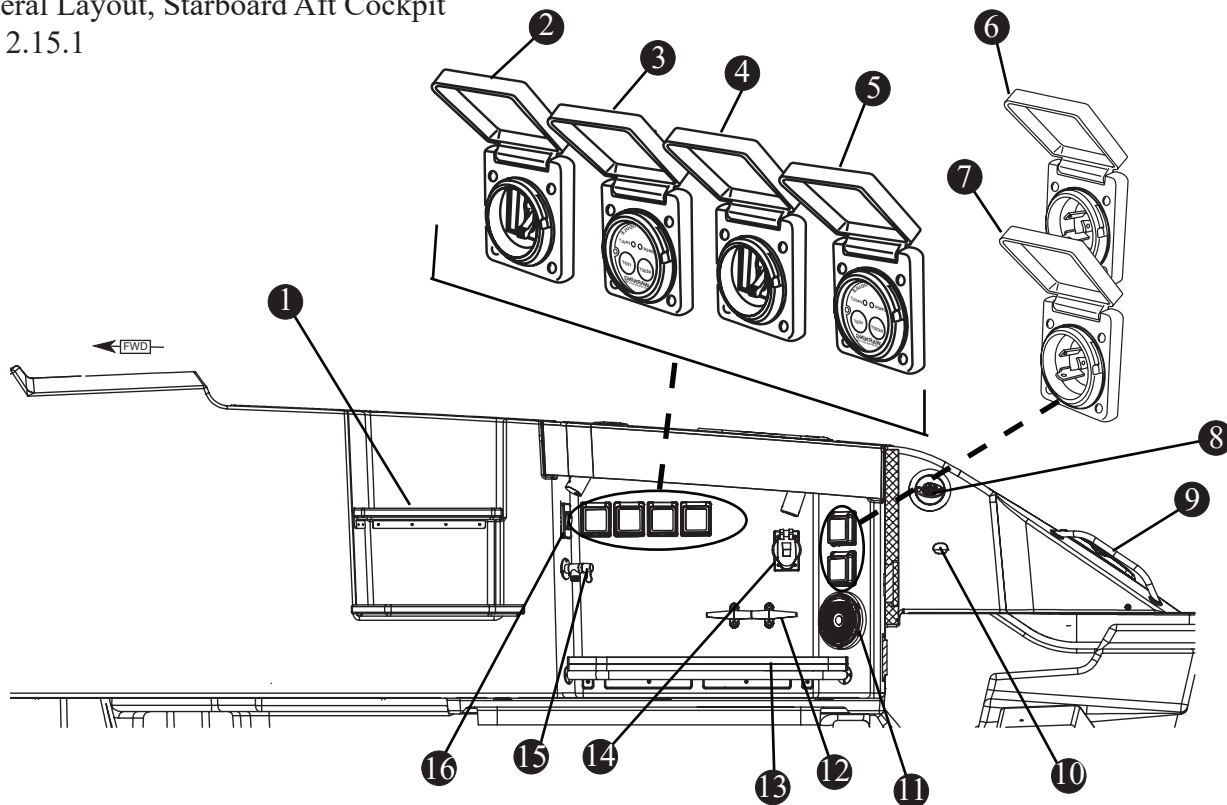

- ① TEAK BOARDING STEPS
- ② SHORE POWER MAIN SWITCH
- ③ ELCI (EQUIPMENT LEAKAGE CIRCUIT INTERRUPTER)
- ④ LINE 2 SHORE POWER MAIN BREAKER (OPTION)
- ⑤ ELCI (EQUIPMENT LEAKAGE CIRCUIT INTERRUPTER) (OPTION)
- ⑥ SHORE POWER RECEPTACLE
- ⑦ LINE 2 SHORE POWER RECEPTACLE (OPTION)
- ⑧ TRANSOM FRESH WATER SHOWER
- ⑨ GRAB RAIL
- ⑩ COURTESY LIGHT
- ⑪ WATERPROOF STEREO SPEAKER (P&S)
- ⑫ AFT CLEAT
- ⑬ DOWNRIGGER WEIGHT HOLDER (P&S)
- ⑭ 12V/30AMP DC RECEPTACLE FOR ELECTRIC REELS AND/OR DOWNRIGGERS (P&S) (OPTION)
- ⑮ FRESH WATER WASHDOWN
- ⑯ COCKPIT COURTESY LIGHTS SWITCH

General Layout (Cont'd)

General Layout, Prep Station
Fig. 2.16.1

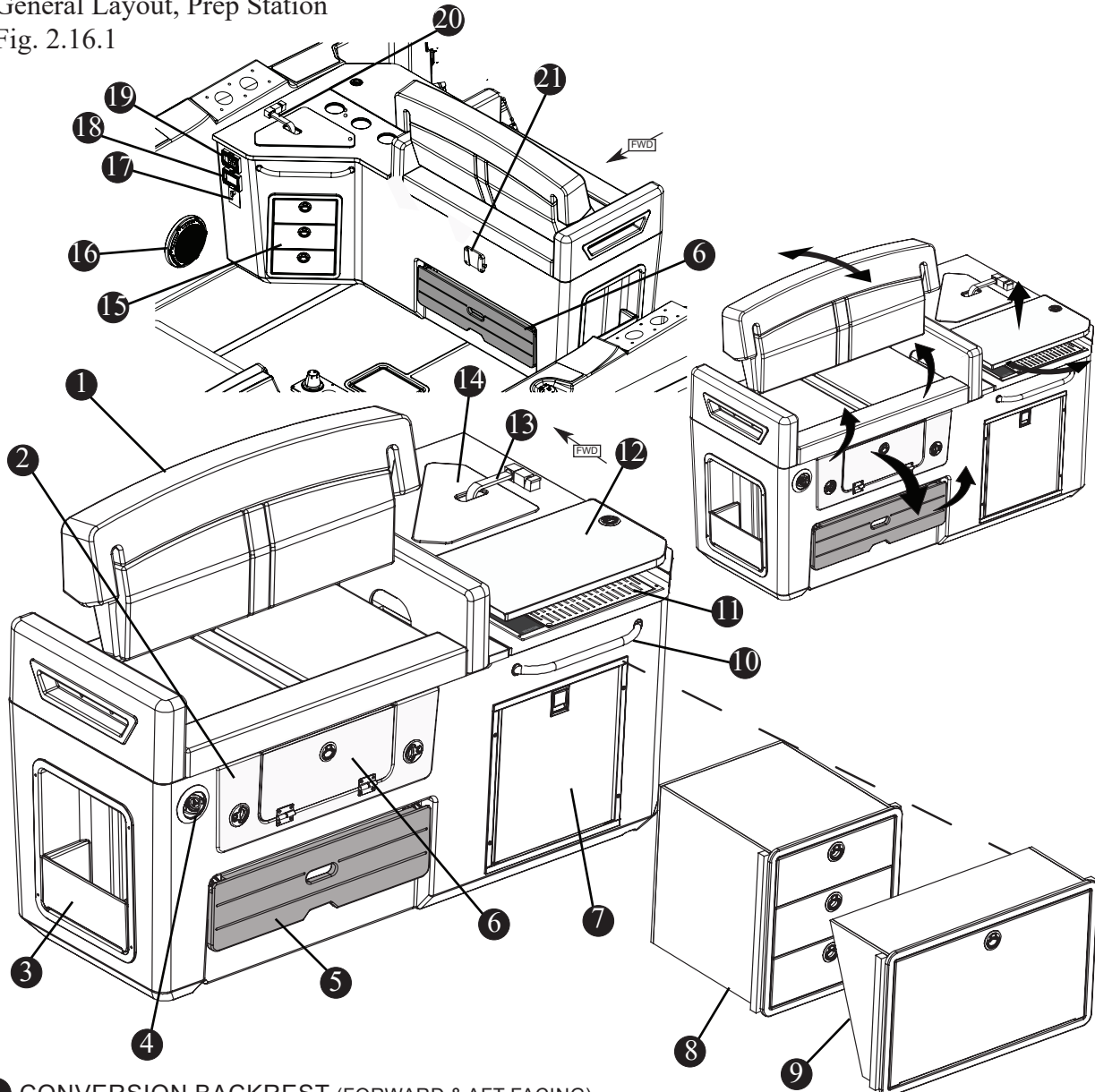

- | | | | |
|----|---|----|---|
| 1 | CONVERSION BACKREST (FORWARD & AFT FACING) | 15 | STORAGE |
| 2 | 230 QT (870.56 L) BUILT -IN COOLER/STORAGE | 16 | STEREO SPEAKER (OPTION) |
| 3 | POCKET STORAGE | 17 | MANUAL FIRE SUPPRESSION PANEL |
| 4 | HOT AND COLD FRESH WATER EXPANDABLE SHOWER | 18 | 120V GFCI RECEPTACLE |
| 5 | FLIP DOWN TEAK FOOTREST | 19 | 120V RECEPTACLE |
| 6 | ADDITIONAL ACCESS TO COOLER/STORAGE | 20 | HOT/COLD PREP STATION FAUCET |
| 7 | 12V/120V 2.3 CU FT REFRIGERATOR* | 21 | BRACKET FOR REMOVABLE TEAK TABLE (OPTION) |
| 8 | 3-DOOR STORAGE CABINET (OPTION) | | |
| 9 | TIP OUT STORAGE CABINET (OPTION) | | |
| 10 | GRAB RAIL | | |
| 11 | KENYON ELECTRIC GRILL | | |
| 12 | CUSTOM SOLID SURFACE COUNTER W/ POP-UP ROTATION | | |
| 13 | HOT & COLD FRESHWATER FAUCET | | |
| 14 | SINK W/ COVER | | |

* Not available with gyroscopic stabilizer option

General Layout (Cont'd)

General Layout, hardtop

Fig. 2.17.1

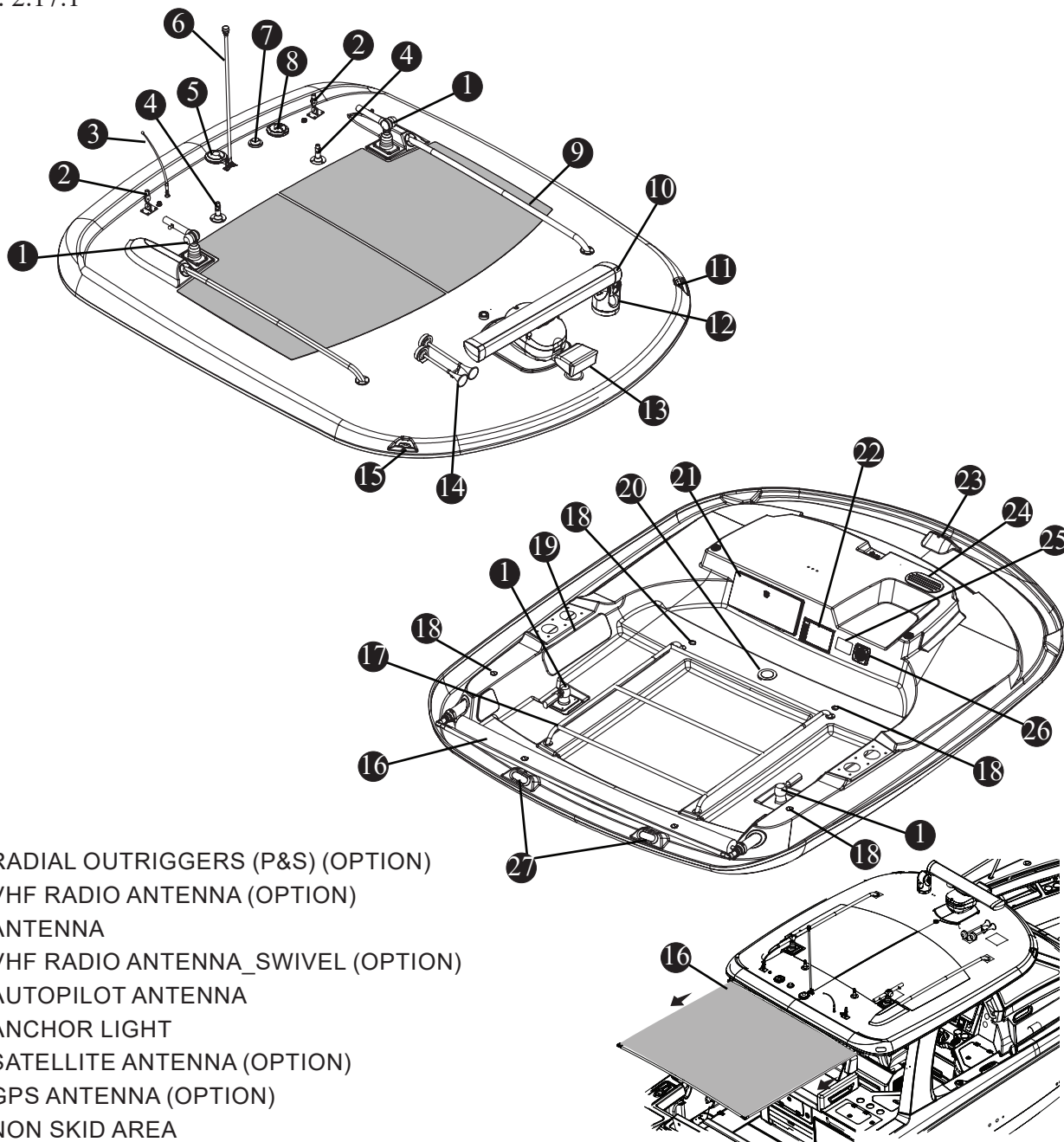

- ① RADIAL OUTRIGGERS (P&S) (OPTION)
- ② VHF RADIO ANTENNA (OPTION)
- ③ ANTENNA
- ④ VHF RADIO ANTENNA_SWIVEL (OPTION)
- ⑤ AUTOPILOT ANTENNA
- ⑥ ANCHOR LIGHT
- ⑦ SATELLITE ANTENNA (OPTION)
- ⑧ GPS ANTENNA (OPTION)
- ⑨ NON SKID AREA
- ⑩ RAYMARINE 4KW HD DIGITAL 48" OPEN ARRAY ANTENNA (OPTION)*
- ⑪ PORT NAV LIGHT
- ⑫ THERMAL NIGHT VISION (OPTION)
- ⑬ SPOTLIGHT WITH REMOTE (OPTION)
- ⑭ ELECTRIC HORN
- ⑮ STARBOARD NAV LIGHT
- ⑯ RETRACTABLE SUNSHADE (OPTION)
- ⑰ CANVAS STORAGE
- ⑱ BLUE LED COURTESY LIGHT

- ⑲ WIRING ACCESS PANEL(P&S)
- ⑳ RED/WHITE LED MAP LIGHT
- ㉑ LOCKABLE ELECTRONICS BOX
- ㉒ VESSEL VIEW 7
- ㉓ FORWARD COCKPIT FLOOD LIGHT
- ㉔ A/C VENT
- ㉕ GYRO DISPLAY (OPTION)
- ㉖ VHF RADIO SPEAKER (OPTION)
- ㉗ AFT COCKPIT FLOOD LIGHT

General Layout (Cont'd)

General Layout, Cabin Interior_Port
Fig. 2.18.1

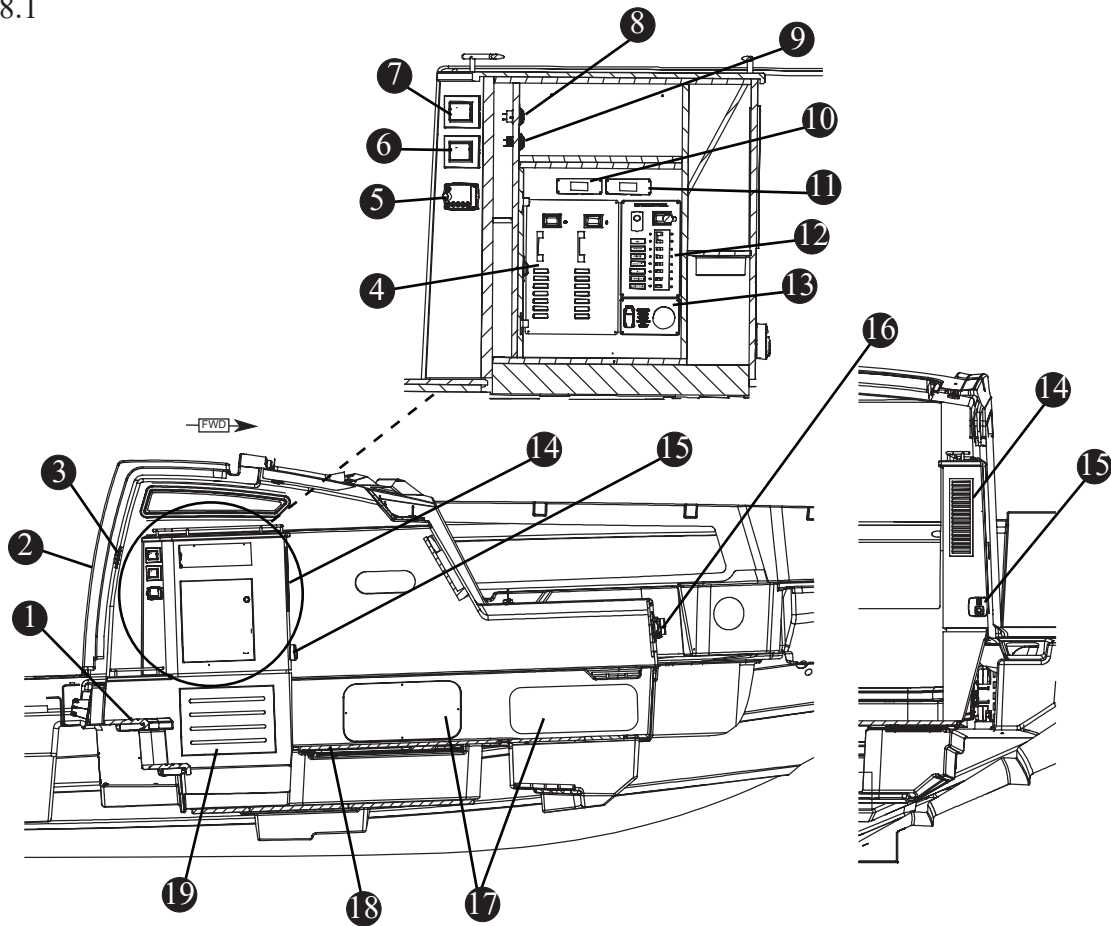

- | | |
|---------------------------------|---------------------------------|
| ① ENTRY STEPS | ⑪ STARBOARD FREEZER PLATE |
| ② ENTRY DOOR | ⑫ DC DISTRIBUTION PANEL |
| ③ CABIN LIGHT SWITCH | ⑬ GENERATOR CONTROL PANEL |
| ④ AC DISTRIBUTION PANEL | ⑭ A/C VENT |
| ⑤ STEREO REMOTE | ⑮ CO MONITOR |
| ⑥ HELM A/C SMART TOUCH DISPLAY | ⑯ STEREO SPEAKER (OPTION) |
| ⑦ CABIN A/C SMART TOUCH DISPLAY | ⑰ ACCESS PANEL TO ELECTRONICS |
| ⑧ 12V ACCESSORY RECEPTACLE | ⑱ PORT LOUNGE (CONVERTS TO BED) |
| ⑨ DUAL USB CHARGER | |
| ⑩ PORT FREEZER PLATE PANEL | |

Section 2 • General Information

General Layout (Cont'd)

General Layout, Cabin Interior_Starboard
Fig. 2.19.1

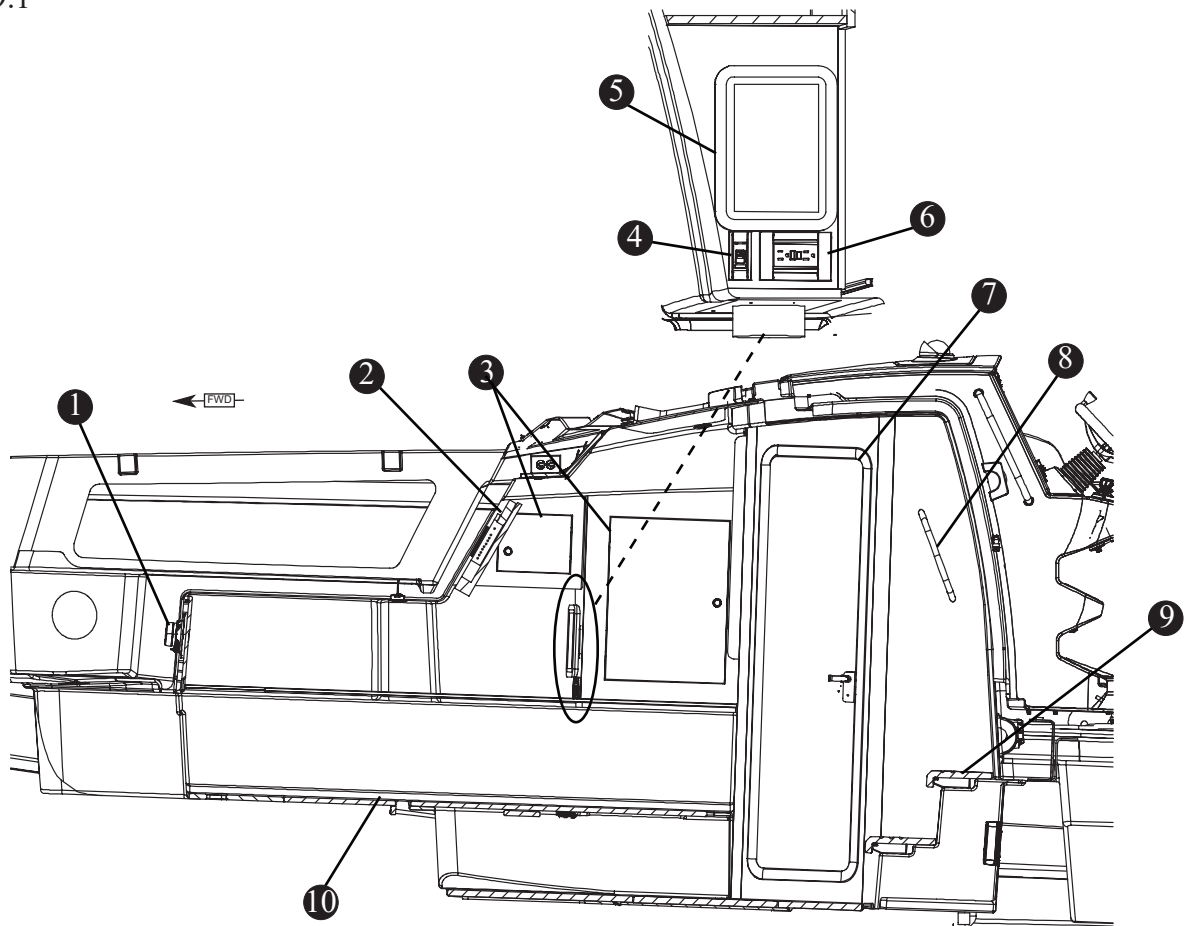

- | | |
|---|--------------------------------------|
| ① STEREO SPEAKER | ⑥ 120V GFI RECEPTACLE |
| ② 28" FLAT SCREEN HDTV | ⑦ HEAD ENTRY DOOR |
| ③ STORAGE CABINET | ⑧ GRAB RAIL |
| ④ USB CHARGER | ⑨ ENTRY STEPS |
| ⑤ IPAD W/WIRELESS CHARGING &
DIGITAL VESSEL CONTROL AND
INFORMATION | ⑩ STARBOARD LOUNGE (CONVERTS TO BED) |

General Layout (Cont'd)

General Layout, Cabin Interior_Head
Fig. 2.20.1

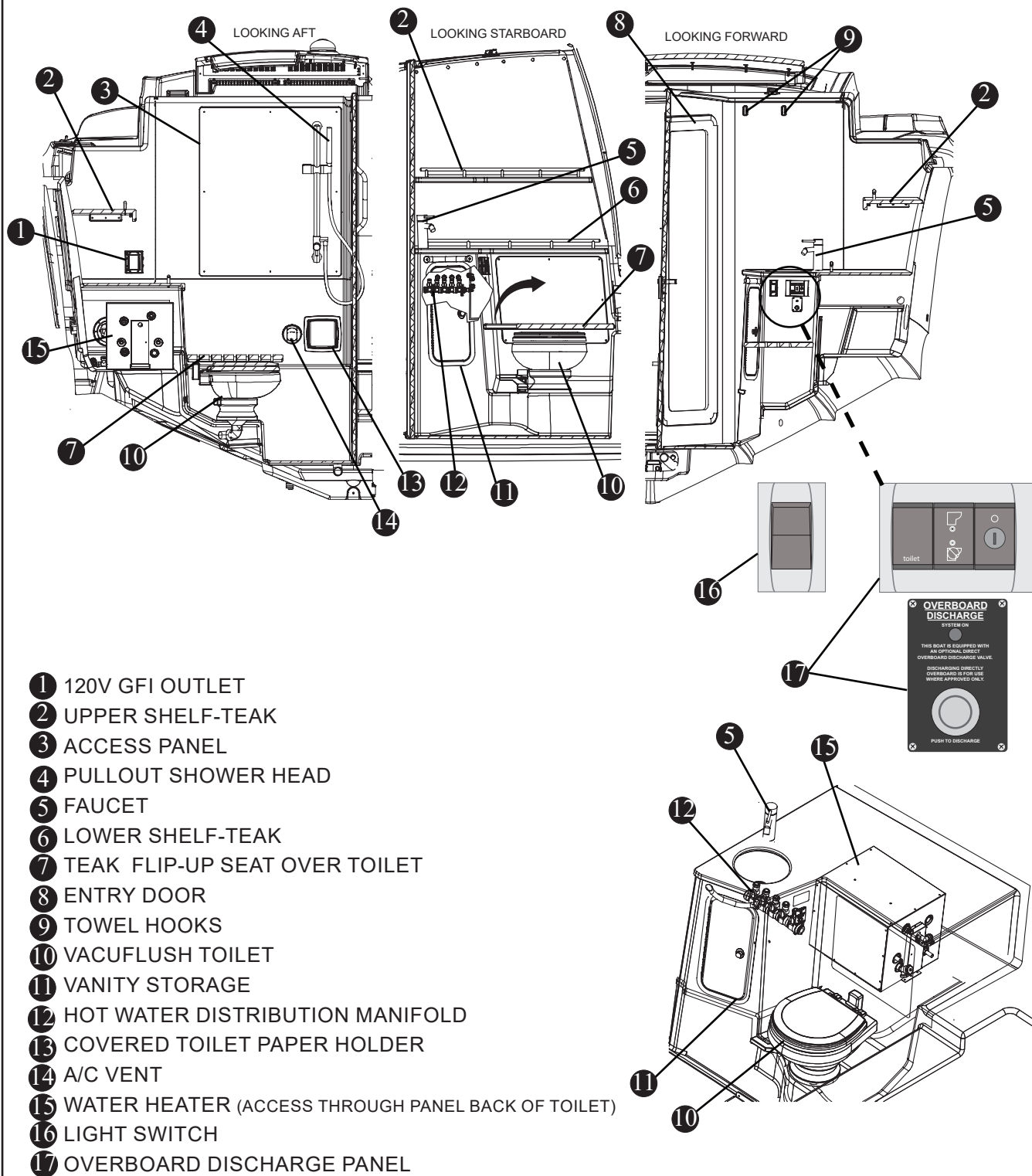

Section 2 • General Information

General Layout, Control Station Seating
Fig. 2.21.1

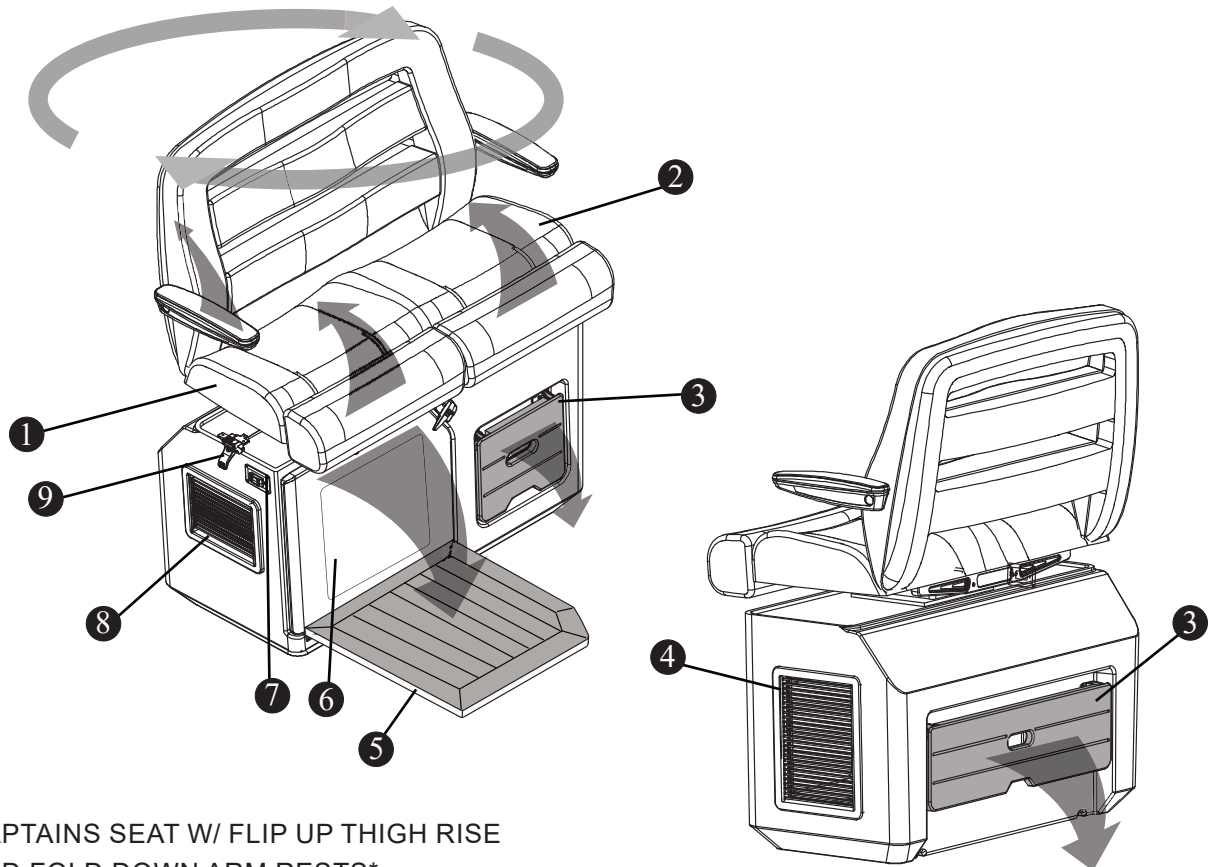

- ① CAPTAINS SEAT W/ FLIP UP THIGH RISE AND FOLD DOWN ARM RESTS*
- ② COMPANION SEAT W/ FLIP UP THIGH RISE AND FOLD DOWN ARM RESTS
- ③ FLIP DOWN TEAK FOOTREST
- ④ HELM DECK A/C AIR INTAKE
- ⑤ FOLD DOWN VISIBILITY PLATFORM

- ⑥ ACCESS PANEL
- ⑦ ELECTRIC SLIDE (FORE & AFT) SWITCH
- ⑧ HELM DECK A/C VENT
- ⑨ 180° SWIVEL RELEASE LEVER

* Adjustable electric slide fore & aft, 180 degree rotation.

Seating

Seating
Fig. 2.22.1

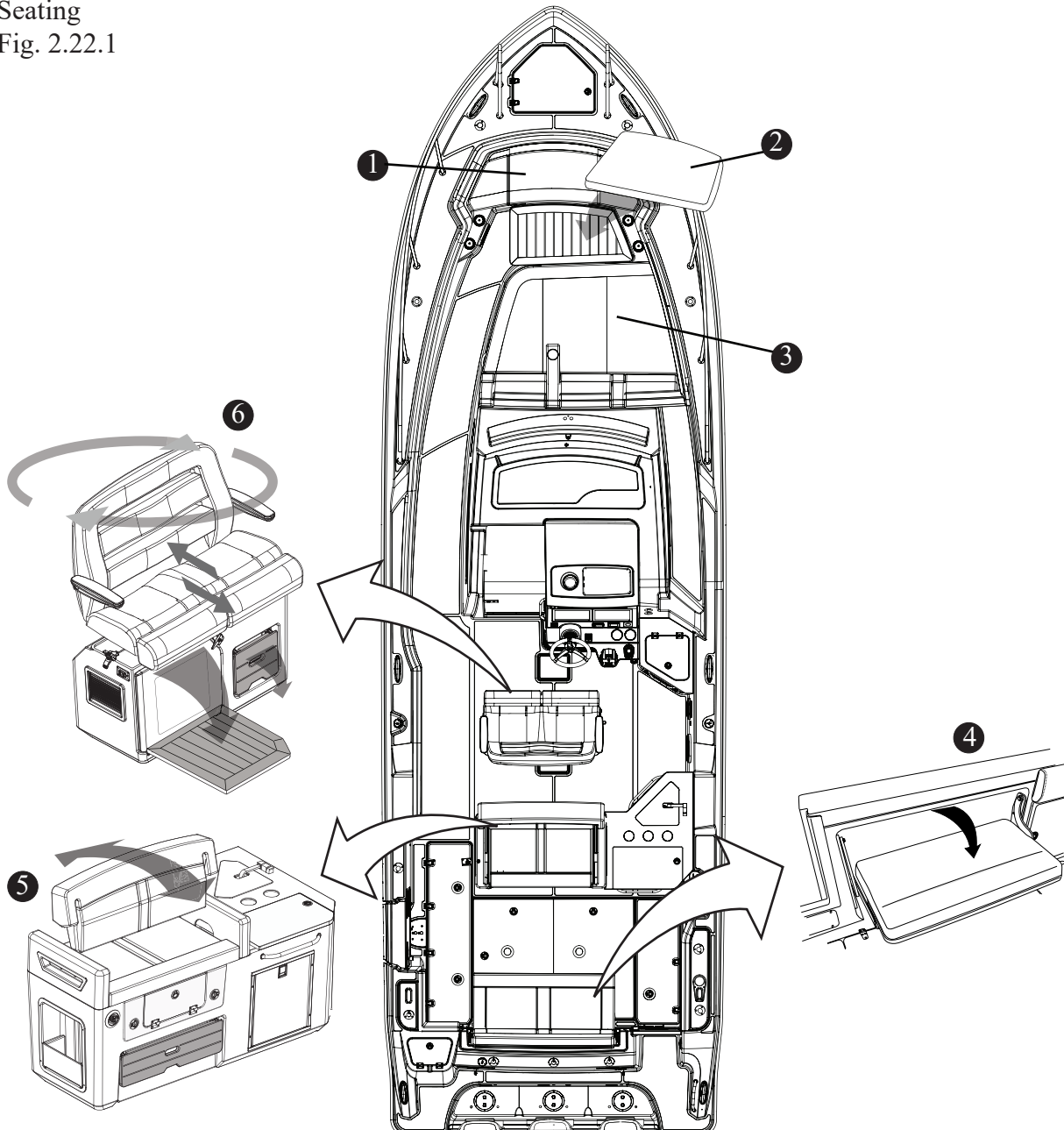

- ① BOW WRAP AROUND SEATING
- ② BOW TABLE FILLER CUSHION
- ③ BOW LOUNGE W/BACKREST AND FOLD-DOWN ARMRESTS (3)
- ④ FOLD OUT STERN SEAT
- ⑤ HELM DECK 2ND ROW SEAT W/CONVERSION SEATBACK (FORE & AFT FACING)
- ⑥ DELUXE SWIVEL HELM SEAT W/FOLD-DOWN ARMRESTS

NOTICE

SEAT MAINTENANCE

- Always wash metallic parts with soap and water and rinse thoroughly with fresh water. Once dry, apply a light coating of lubricant to protect moving parts.
- Check for loose or damaged hardware and tighten or replace as necessary.

Notable Options

Notable Options

Fig. 2.23.1

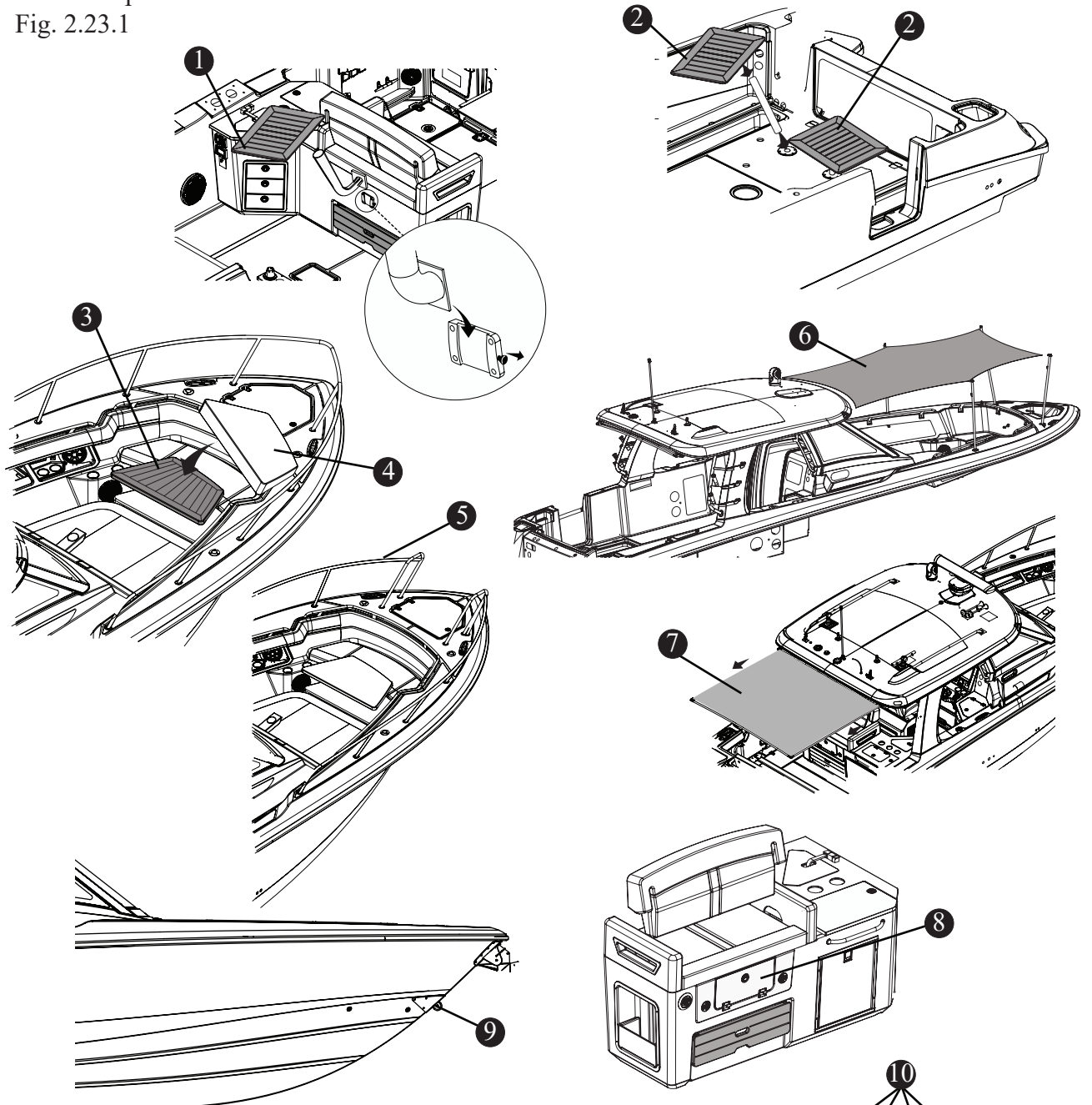

- ① PREP STATION TABLE
- ② COCKPIT TABLES
- ③ BOW TABLE (ELECTRICALLY RAISE AND LOWER)
- ④ BOW TABLE CUSHION
- ⑤ SPLIT BOW RAIL*
- ⑥ BOW SUNSHADE
- ⑦ ELECTRICALLY ACTUATED, HARDTOP SUNSHADE
- ⑧ 32 GAL (121.12 L) PRESSURIZED LIVEWELL
- ⑨ BOW TOW EYE
- ⑩ UNDERWATER LIGHTS (6)

* Not available with mooring cover

Switch Panel

Helm Switch Panel

Fig. 2.24.1

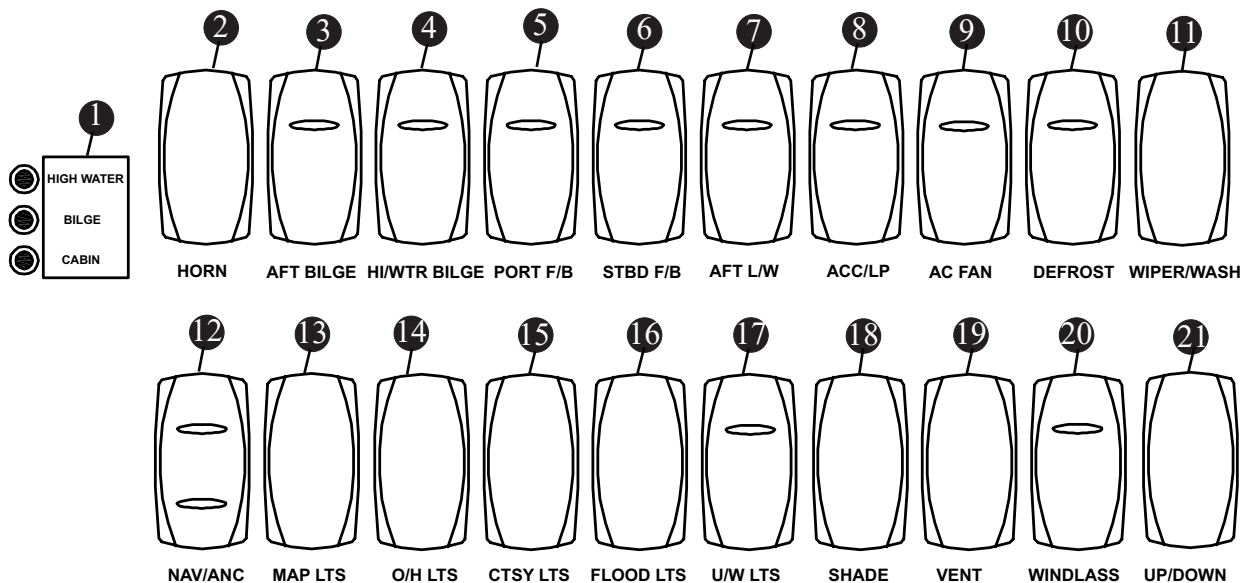
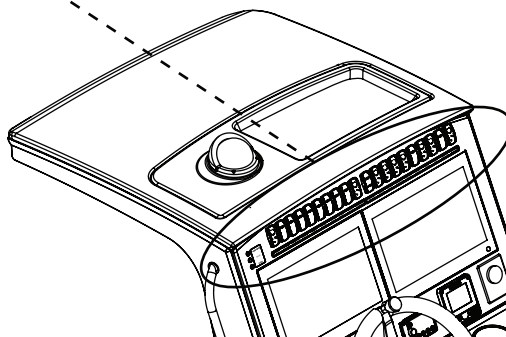

- | | |
|--------------------------|------------------------------|
| ① BILGE PUMP ALERT PANEL | ⑫ NAV/ANCHOR LIGHT |
| ② HORN | ⑬ MAP LIGHT |
| ③ AFT BILGE PUMP | ⑭ OVERHEAD LIGHTS |
| ④ HIGH WATER BILGE PUMP | ⑮ COURTESY LIGHTS |
| ⑤ PORT FISH BOX | ⑯ FLOOD LIGHTS |
| ⑥ STARBOARD FISH BOX | ⑰ UNDERWATER LIGHTS (OPTION) |
| ⑦ AFT LIVWELL | ⑱ SUN SHADE (OPTION) |
| ⑧ LEANING POST ACCESSORY | ⑲ WINDSHIELD VENT |
| ⑨ AC FAN | ⑳ WINDLASS |
| ⑩ WINDSHIELD DEFROSTER | ㉑ WINDLASS UP/DOWN |
| ⑪ WINDSHIELD WIPER/WASH | |

Joystick Piloting (Option)

Joystick technology is the latest enhancement in vessel control, providing effortless maneuverability. The joystick Piloting system replaces the traditional bow thruster set up. Joystick Piloting takes the stress out of docking, maneuvering in tight spaces and operating in less-than-ideal environments by providing the vessel operator 360-degree movement at their fingertips.

The system allows the operator to effortlessly move a multi-engine boat in any direction - including sideways, diagonally or spinning on its own axis - with a simple push or twist of a joystick. The operator controls the throttle, shifting and steering with one hand, with the joystick working in conjunction with the independently steered engines to move the boat in the desired direction.

If equipped, the joystick is located on the control console forward of the throttle/gearshift.

System Features

Digital Throttle & Shift (DTS)

Amazingly smooth and responsive, DTS replaces the lag and hesitation of traditional throttle and shift

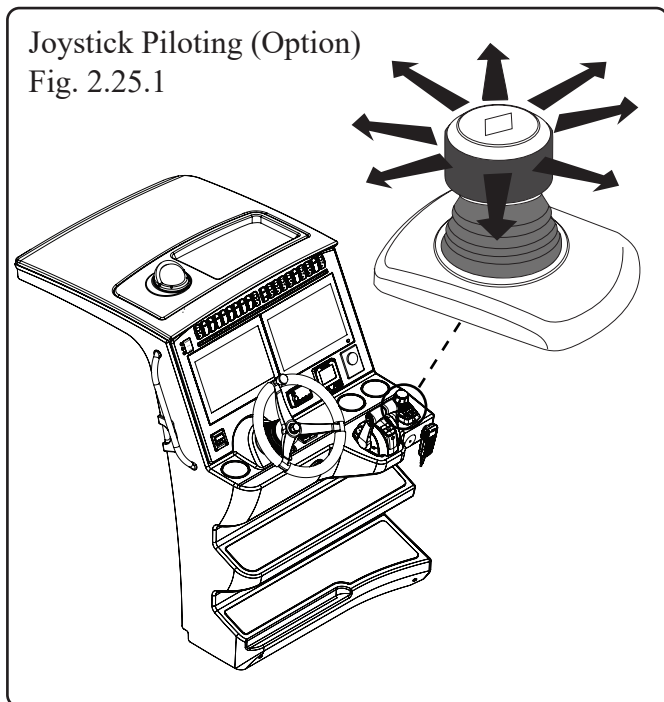

REFER TO THE MANUFACTURER'S MANUAL IN YOUR OWNER'S PACKET FOR COMPLETE INSTRUCTIONS AND WARRANTY.

cables with digital precision, resulting in smooth shifting and instant throttle response. DTS includes many advanced features to improve your boating experience. Auto Sync synchronizes multiple engine rpms automatically and Single Lever Mode allows you to control multiple engines with just one control lever.

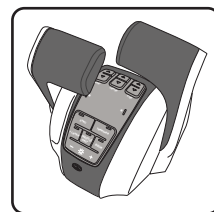

VesselView®

The redesigned VesselView provides up-to-date information for more than 30 engine parameters, including fuel level and range, oil temperature and pressure, water depth and more.

It also provides advanced features such as Smart Tow, ECO-Screen, Troll Control, Cruise Control, and much more.



Skyhook® (digital anchor)

With the push of a button, Skyhook pinpoints the boat's position using a GPS satellite antenna and the engines and drives move independently to maintain the position and heading. It's ideal for holding a boat over a fishing spot, waiting for a drawbridge to open or maintaining position while waiting to refuel at a marina.

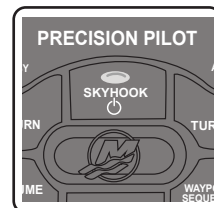

Integrated Autopilot

Auto Heading and Waypoint Sequencing make navigating to a destination simple and efficient. A built-in digital compass on Auto Heading allows the captain to maintain course and make precise corrections with the touch of a finger. One-degree heading adjustments can be made with a tap on the joystick; 10-degree adjustments can be accomplished using the control panel. Trips with multiple stops between the starting point and final destination are a breeze with Waypoint Sequencing, which allows the operator to plot the boat's course using multiple points.

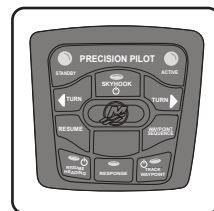

Gear Shift & Throttle Control

! CAUTION

Shift controls into **NEUTRAL** before starting engine. Shift only when engine is at idle. Reversing at high speeds can cause flooding/swamping due to water being pushed over the transom.

NOTICE

Wind and sea currents can change how your boat responds while in motion. Understanding your boat and its reactions at speed will make your boating safer and more enjoyable.

Digital Throttle/Shift (DTS®)

Your boat features a state of the art digital “drive-by-wire” gear shift and throttle control system. The Digital Throttle/Shift (DTS)® is the latest technology in recreational boating.

The DTS® system is monitored through the Smartcraft® VesselView display which will give you a visual readout of all functions regarding your boats engine as well as direction, and applicable fluid capacities.

The throttle control regulates the RPM of the engine. Regulating the RPM of the engine will control the speed of the boat. Moving the lever forward engages the forward gear. Continuing to move the lever forward will increase the forward speed of the boat.

Likewise, to reverse power, bring the control lever back to engage the reverse gear and increase the reverse thrust by continuing to pull back on the throttle control.

The control must be in the “NEUTRAL” position to start your engine(s). Neutral is in the center position of the unit and acts as an idle. While in this position, the propeller is not rotating. By moving the control arms back and forth you can feel a detent in the center position and will hear a click when neutral is engaged.

Digital Throttle/Shift (DTS®)
Fig. 2.26.1

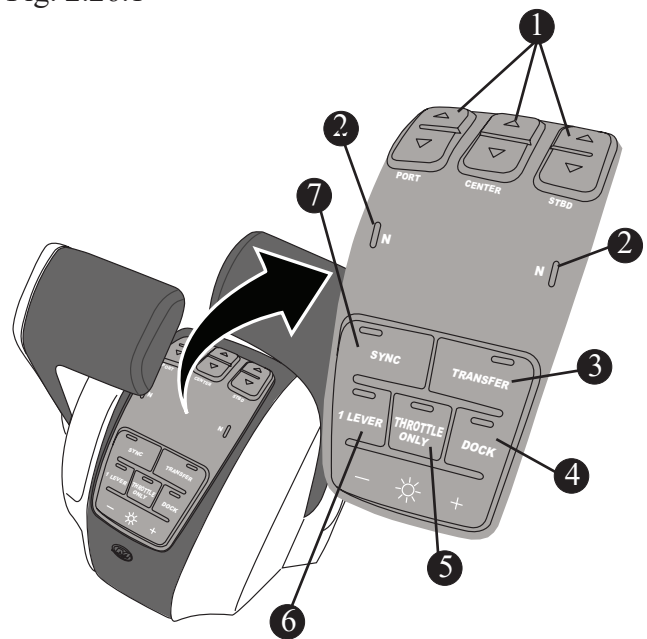

- 1 TRIM/TILT CONTROL SWITCH
- 2 NEUTRAL INDICATOR LIGHT
- 3 TRANSFER SWITCH
- 4 DOCK MODE
- 5 THROTTLE ONLY
- 6 1 LEVER MODE
- 7 SYNC

DTS Control Pad

Dock- Pressing the “DOCK” button initiates docking mode. Docking mode reduces throttle capacity to approximately 50% of normal throttle. To turn off docking mode, shift the engine into neutral and press the “DOCK” button.

Throttle Only- Allows the operator to increase engine RPM for warm-up without engaging the propeller. To engage throttle only, move the control handle to neutral, press the “throttle only” button and move the throttle(s) ahead to the forward detent. The horn will sound once and the neutral lights will flash. The horn will sound twice when throttle only is engaged. Advance the throttle(s) to increase engine

RPM. To disengage, return control handle to neutral and press the “throttle only” button.

1 Lever- Pressing the “1 LEVER” button initiates single lever mode. Single lever mode enables the throttle and shift functions of all engines to be controlled by the port control handle. To turn off single lever mode, shift into neutral and press the “1 LEVER” button.

Shadow Mode Technology

With triple engines, the DTS® system incorporates Shadow Mode Technology which enables the center engine to “shadow” or follow the outboard engines when the outboard engines are in the same gear.

When the outboard engines are in opposite gears, as they would be for docking maneuverability, the center engine automatically defaults to neutral. This gives the operator greater control when docking.

Auto Sync®

The unique Auto Sync feature has been designed to synchronize ALL engines, automatically, when the port and starboard control levers are within 10 degrees of each other and the engines are running above 1500 rpm and below 95 percent throttle. This feature eliminates the need for the levers to be perfectly aligned in order to synchronize the three engines.

Transfer

Station transfer allows engine control to be transferred from one control station to the other.

Power Trim

ATTENTION

Ensure continuous visibility of other boats, swimmers and obstacles during bow-up transition to planing. Adjust engine to an intermediate trim as soon as boat is on plane.

The power trim & tilt system located on the shift control lever (Fig. 2.19.1) allows you to raise and lower the engine to achieve optimum performance and is used for trailering, launching and beaching.

Operation

The engine trim is controlled by a momentary rocker switch, where constant pressure must be applied to the switch during the raising and lowering cycles. Use the power trim switch to obtain ideal boat angle (in relation to the water surface) for a given load and water condition. In most cases the best all-round performance is obtained when the boat runs at an angle between a 3 to 5 degrees.

REFER TO THE ENGINE MANUFACTURER'S MANUAL IN YOUR OWNER'S MANUAL PACKET FOR COMPLETE INSTRUCTIONS AND WARRANTY INFORMATION.

Trim Switch Control

Fig. 2.27.1

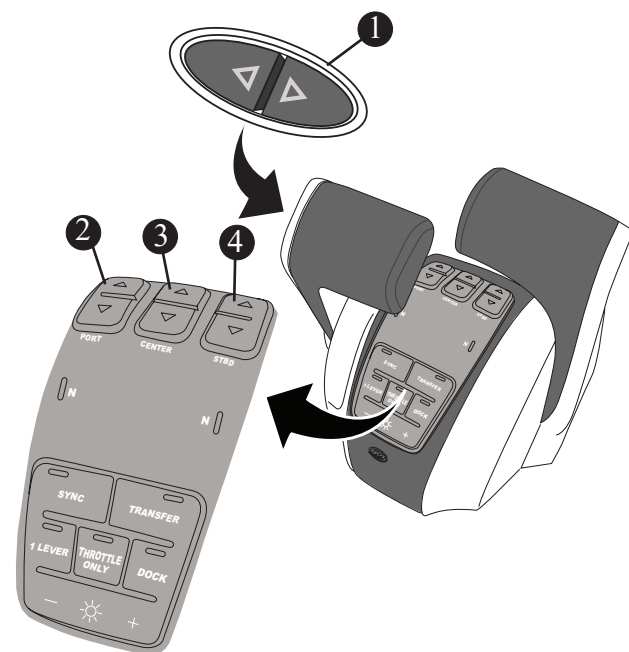

- ① ALL ENGINES TRIM SWITCH
- ② PORT ENGINE TRIM SWITCH
- ③ CENTER ENGINE TRIM SWITCH
- ④ STARBOARD ENGINE TRIM SWITCH

Power Trim and Trim Tabs

Although power trim can be used to adjust the boat's attitude in the water, it is highly inefficient. A propeller is designed to move the boat forward. When trimming the boat with the propeller you are asking the prop to not only push the boat forward but raise the stern also. This situation greatly increases prop slippage thereby wasting RPM's. In addition, power trim cannot correct listing and is inefficient at slow speeds.

When power trim is used in combination with the trim tabs the hull and the prop can be trimmed independently for maximum performance and efficiency.

To achieve maximum performance, first adjust the trim tabs to the desired running attitude. Then, using the power trim, adjust the prop parallel to the water flow. It may be necessary to re-adjust and fine tune the trim tabs to achieve optimum attitude and performance.

Trim Guidelines

When running in choppy waters it is suggested that you trim your prop out to keep the bow high and proceed at slower speed with caution.

Running in heavy seas (3-4 feet) requires increased attention to the control of your boat. As such it is best to trim the engine far enough down to keep the boat level and on plane at slower speeds.

CAUTION

AVOID DAMAGE

Be aware that the port engine cowl can hit the livewell if the engine is turned to the port and trimmed fully up.

REFER TO THE ENGINE MANUFACTURER'S MANUAL IN YOUR OWNER'S MANUAL PACKET FOR COMPLETE INSTRUCTIONS, INFORMATION AND WARRANTY.

Active Trim (Option)

If equipped, the Active trim panel is located on the forward hardtop above the console.

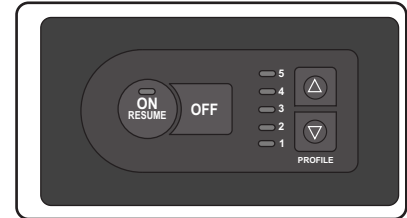

Active Trim provides the benefit of perfect trimming without constantly monitoring and adjusting trim with changes to boat speed or when going into turns.

Active Trim controls the trim in accordance with boat speed and engine rpm. This avoids potential problems such as engines trimming up (instead of down) if the propeller breaks loose in a hard turn. It also avoids issues with the engine trimming up too early or too late when the boat is getting on plane.

Active Trim has five selectable trim profiles that accommodate nearly any boat application. These profiles allow operators to compensate for changes in boat load, operator preference and weather conditions, while maintaining full auto operation.

REFER TO THE MANUFACTURER'S MANUAL IN YOUR OWNER'S PACKET FOR COMPLETE INSTRUCTIONS AND WARRANTY.

Theft Deterrent System/Whaler Watch

The Theft Deterrent System (TDS) Premium is a GPS tracking system with satellite communication. The system provides the owner the opportunity to continuously monitor the location of the vessel through a secure website.

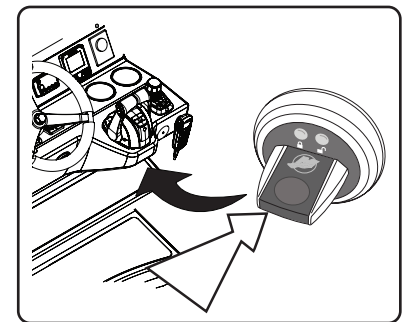

The system uses GPS coordinates to monitor the vessel's location. When the vessel crosses the security fence boundary, the satellite network will send an alert e-mail or text message to the addresses designated by the vessel owner.

Section 2 • General Information

Your Whaler Watch system provides the following features:

- Anti-theft security key fob with engine immobilization
- Boston Whaler proprietary vessel monitoring system
- Cellular and satellite 24-hour monitoring system providing world-wide coverage
- Monitor engines, tanks, batteries, shore power and high-water sensor with alert notification
- Telematics tracking system with GeoFence alert notification
- Free limited time monitoring/control subscription included
- Refer to Chapter 3 for additional operation information

REFER TO THE MANUFACTURER'S MANUAL IN YOUR OWNER'S PACKET FOR COMPLETE INSTRUCTIONS AND WARRANTY.

VesselView

Your boat is equipped with the SmartCraft Vessel View feature. The display unit is located at the center of the hardtop above the console.

VesselView allows the boat's operator to receive a wealth of critical operational information, displayed clearly and instantly at the helm on the display. VesselView continuously monitors and reports information ranging from basic operating data to detailed vessel environment information.

System Calibration (For First Time Use)

Boston Whaler or your Boston Whaler dealer has calibrated VesselView to the equipment on your boat. If equipment is added, the system will need to be recalibrated.

For recalibrating or manufacturers information regarding the Smartcraft VesselView refer to the manufacturer's owner's manual found in your owner's packet.

REFER TO THE MANUFACTURER'S MANUAL IN YOUR OWNER'S MANUAL PACKET FOR COMPLETE INSTRUCTIONS, INFORMATION AND WARRANTY.

VesselView Mobile

VesselView Mobile connects the SmartCraft data network to your iPhone or android mobile device via Bluetooth Low Energy4.0(BLE). With VesselView Mobile you have the power of SmartCraft on your mobile device with all the digital data your SmartCraft engine supports plus new features such as:

- Maintenance reminders
- Mapping
- Performance summary
- Fault code diagnostics

SmartCraft VesselView

Fig. 2.29.1

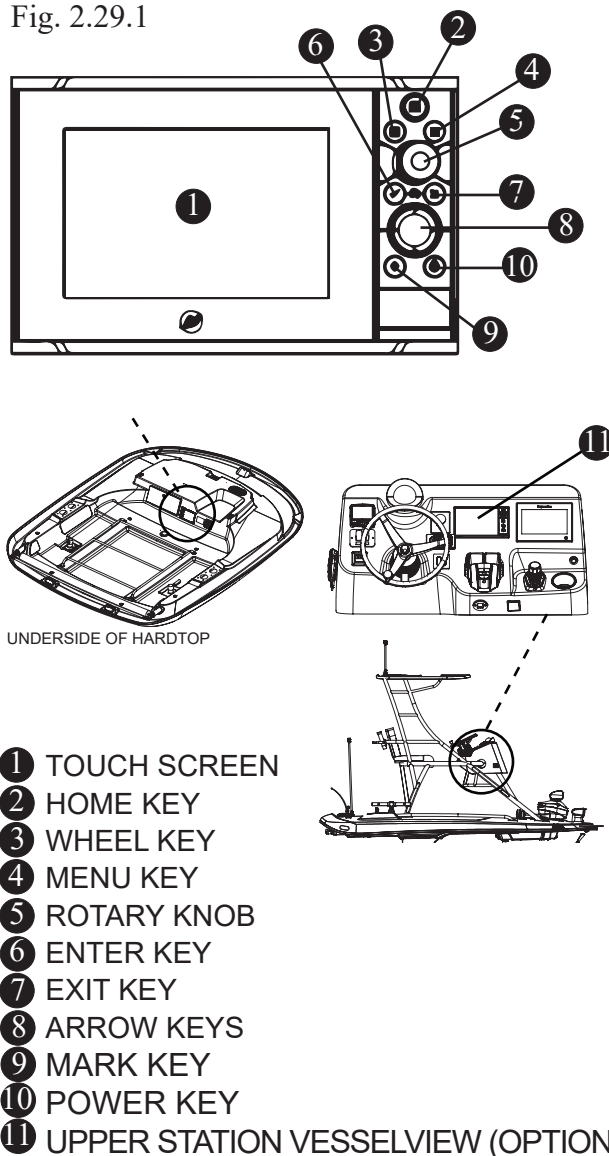

Navigation Lighting

NOTICE

Regulations state that all boats, no matter the size, must display navigation lights.

Your boat comes equipped with navigation lighting for your safety. Regulations state that all boats must display navigation lights between sunset and sunrise and during periods of restricted visibility, such as rain, fog, haze, etc. If operating in reduced visibility or between sunset and sunrise it is necessary to maintain a safe speed and post a lookout.

It is the responsibility of the operator to ensure that the navigation lights are in good working order and that the proper lighting is shown and not obstructed in its intended arc of visibility. This vessel's navigation lights may include an expiration date on the housing. If one is located, replace light before expiration date,

even if light is functional, as lighting quality may be compromised.

Do not add lights that interfere with required navigation lights. Some lights, such as blue colored lights, may be illegal to display on a boat. It is the owner's responsibility to ensure that displayed lights are also compliant with local regulations.

Operating the Navigation Lighting

A three-position switch, located on the console switch panel marked “NAV/ANC” (See fig. 2.30.2) controls the navigation and anchor lighting. In the “Navigation Lights” position the port (red), starboard (green) and all around (white) lights will illuminate. These lights let other vessels know the approximate size and direction of travel of your boat, depending on which lights they can see. In the “Anchor Lights” position, the white, 360°, all around light will illuminate, showing other boaters your location while at anchor.

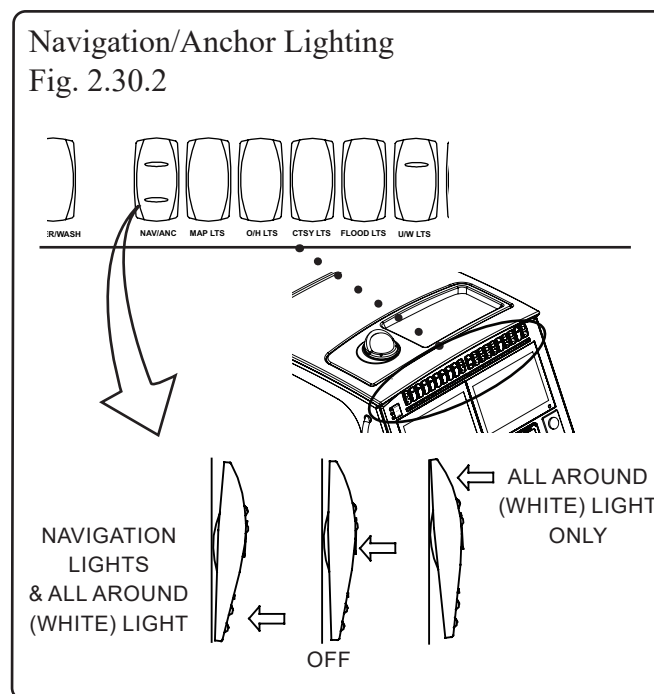
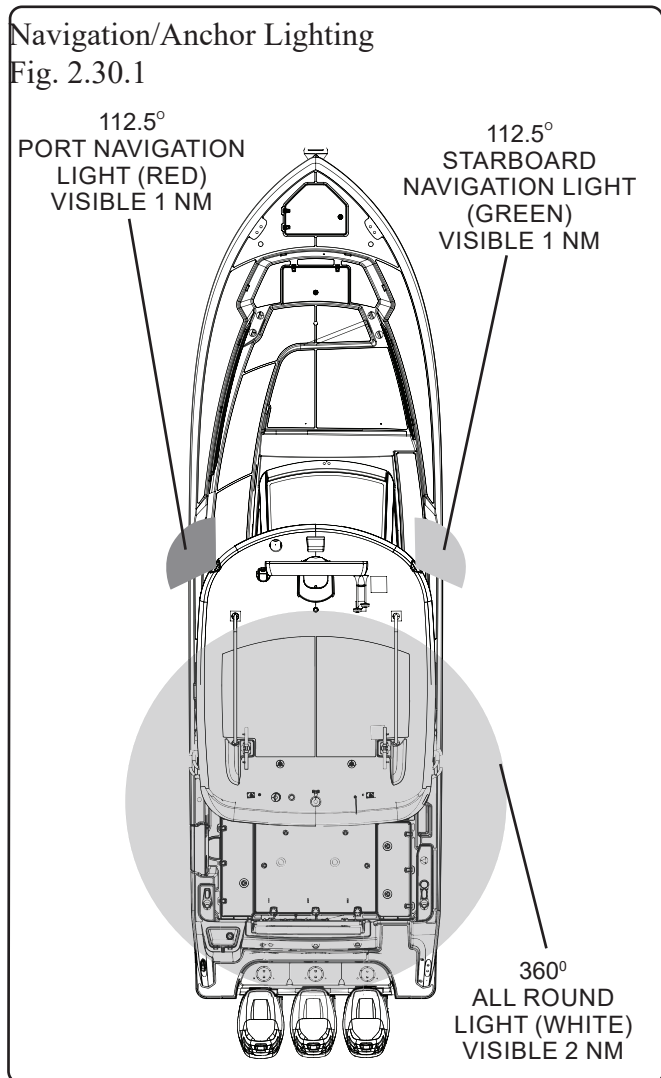

⚠ CAUTION

The improper sequence of navigation lighting may be as dangerous as no lighting at all.

Canvas (Option)

⚠ DANGER

CARBON MONOXIDE DANGER

Prolonged exposure can cause serious injury or death. To reduce CARBON MONOXIDE accumulation, increase air movement by opening windows or adjusting the canvas to allow for more air circulation

The 350 Realm's optional canvas set consists of helm side enclosures with aft drop curtain, wing curtains, helm seat cover, console cover, storage garage cover, forward cushion cover and generator.

Your canvas weather curtain set will keep its appearance and maintain proper working order provided you follow a few simple steps for cleaning and maintenance (see Canvas Care & Maintenance in this manual).

The canvas can be stored in a net pouch and stowed in the cabin.

Removing or installing canvas on the open water can be difficult since rough water or wakes can cause you or your passengers to lose their balance while attempting to install or remove canvas panels.

For your safety and ease of installation or removal of the canvas, use two (2) people to perform the operation. Remove or install canvas before leaving the boat slip.

Storage pouch

Fig. 2.31.1

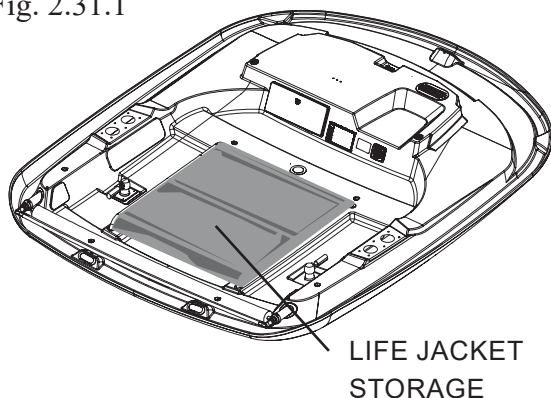

Installation

To install your canvas (for the first time):

Insert the zipper track into the canvas rail around the underside of the hardtop.

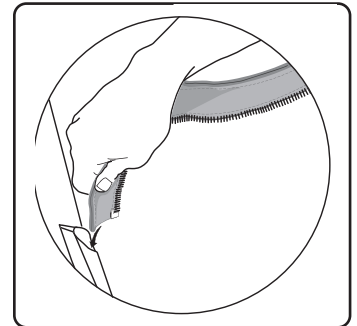

Once installed, it is not necessary to remove the zipper tracks each time you remove the canvas

Zip the canvas panel section(s) to the zipper track to secure the canvas panel. Zip only partially (approx. 4") at first.

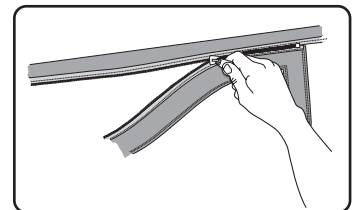

Attach the bottom of the canvas section(s) to the snaps where appropriate.

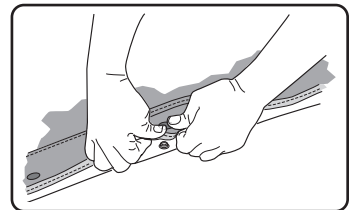

Secure the corners of the canvas with the bungee style fasteners where appropriate.

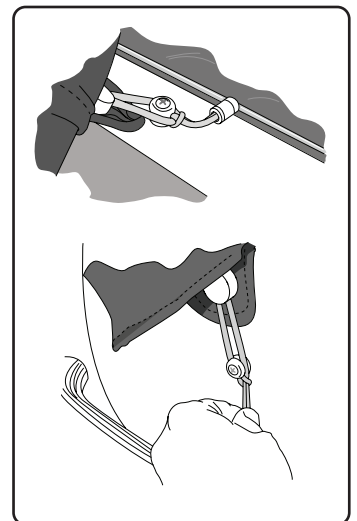

Finish zipping the canvas section(s) carefully without forcing.

Section 2 • General Information

When zippers are new they can be a little difficult to zip. A zipper lubricant may be used to help new zippers as well as maintaining trouble-free service. Use care when starting a zipper to prevent damage.

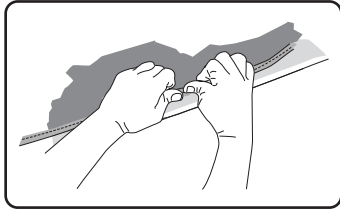

When all canvas is zipped, secure the overlapping edges by pressing them together, thus engaging the hook and loop fabric.

Never remove canvas by pulling roughly on one edge. To prevent damage to the fabric, fasteners should be unsnapped as close to the button as possible. If the snaps become difficult to unsnap use a lubricant for snaps or zippers or vaseline, Chapstick, etc. Take care that the lubricant will not stain the fabric.

To Remove Canvas

- Unzip each piece of canvas leaving approximately 4" attached. This will relieve the tension on the snaps.

- Unsnap the remaining sides of the canvas pieces.
- Remove one piece at a time and store per manufacturers recommendations.

▲ DANGER

Exhaust fumes from engines contain deadly Carbon Monoxide gas (CO). Boats enclosed with canvas or with poor ventilation are most likely to collect fumes.

CO sickness symptoms include headache, nausea and dizziness. DO NOT mistake these symptoms for sea sickness.

Even in rainy and/or cold weather, fresh air must circulate through the boat to avoid Carbon Monoxide poisoning.

See page 1-6 of this manual for additional important information regarding Carbon Monoxide.

REFER TO THE CANVAS MANUFACTURER'S INSTRUCTIONS FOR COMPLETE CARE AND MAINTENANCE OF YOUR CANVAS SET.

Canvas (Option)
Fig. 2.32.1

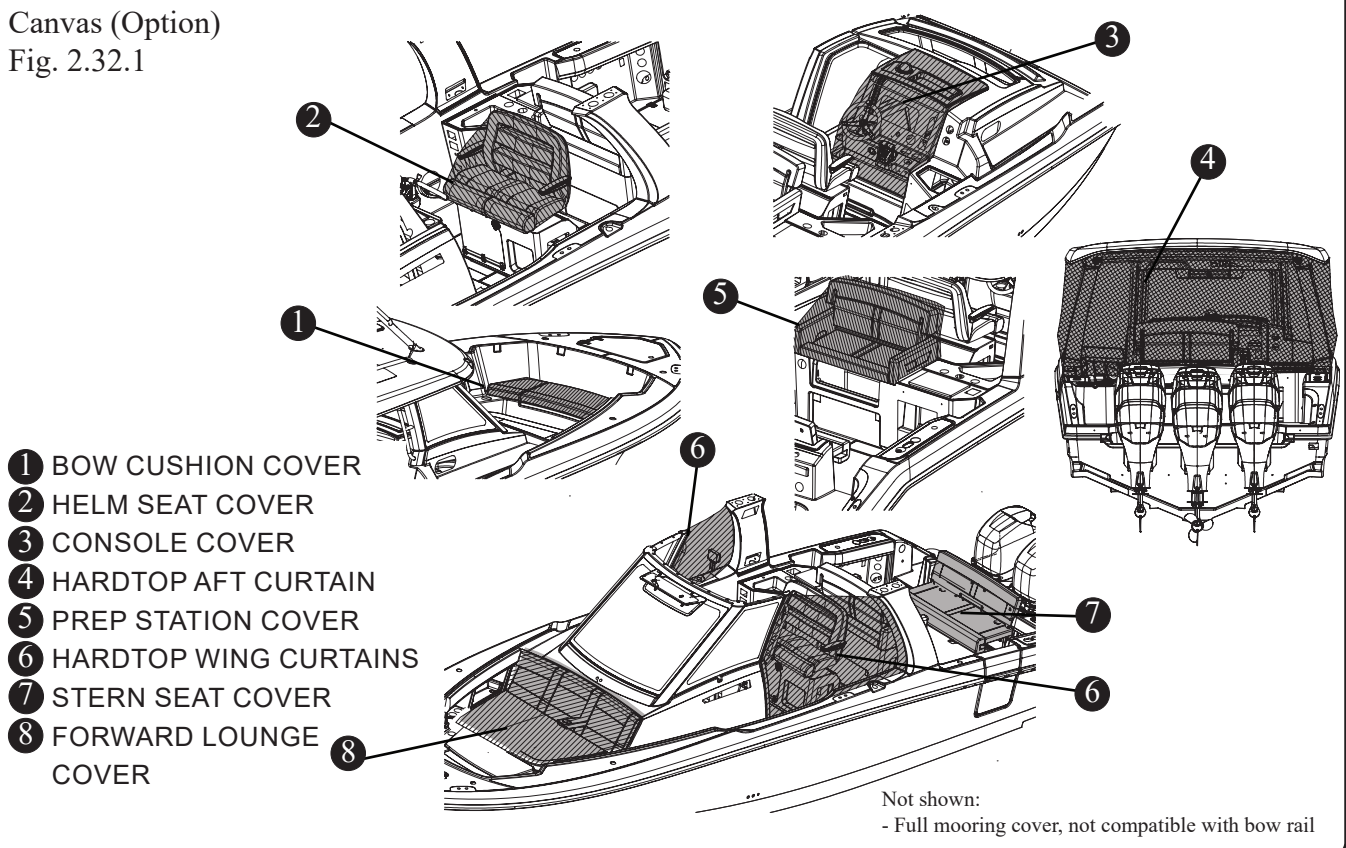

Bow Thruster

NOTICE

Bow thruster is deleted w/ joystick piloting option.

! WARNING

Be sure you thoroughly understand the operation and safety requirements of the thruster before using.

The thruster should not be operated in close proximity to swimmers, as a powerful suction is created when in use.

The bow thruster gives the operator more maneuverability of the bow when docking or maneuvering the vessel in narrow channels or where space is at a premium.

Boston Whaler uses a patent pending design for installation of the bow thruster.

The bow thruster motor, house batteries, battery charger and fuse block can be accessed by lifting the access hatches in the floor of the forward console lounge.

The bow thruster joystick located on the control station switch panel is used to operate the thruster and maneuver the bow of your boat.

Bow Thruster
Fig. 2.33.1

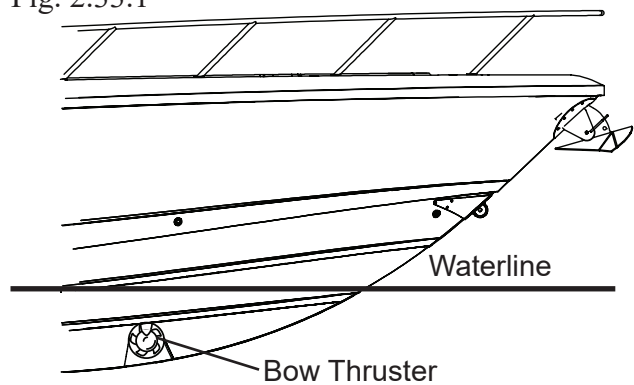

Bow Thruster
Fig. 2.33.2

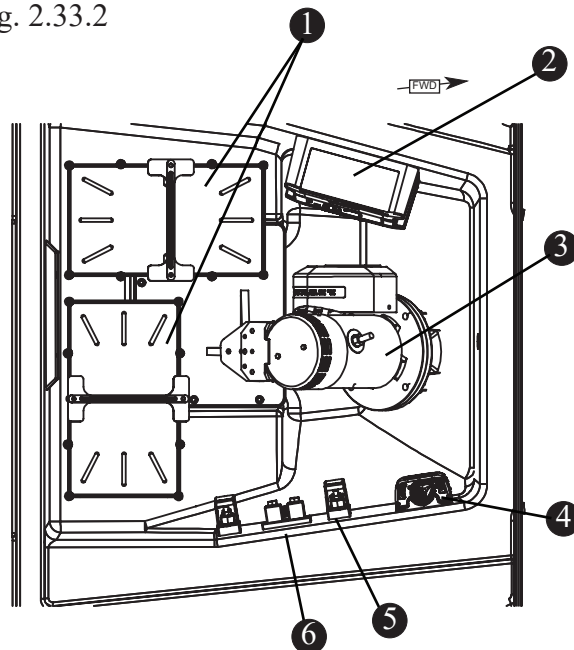

- ① BATTERY TRAYS
- ② FORWARD BATTERY CHARGER
- ③ BOW THRUSTER
- ④ BOW THRUSTER BATTERY SWITCH
- ⑤ FUSE
- ⑥ DC CURRENT SENSOR

Section 2 • General Information

To Operate The Bow Thruster:

- Depress battery switch located on the DC Distribution panel..

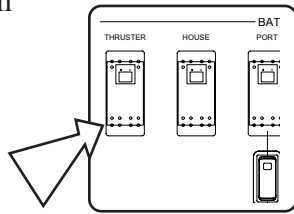

- Press the activation button for 1 second.

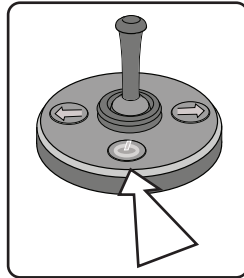

- Lift the joystick and move it in the direction you wish to move the bow.

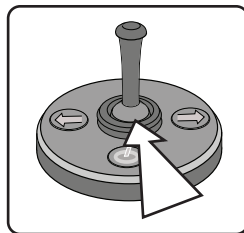

Bow Thruster Movement
Fig. 2.34.1

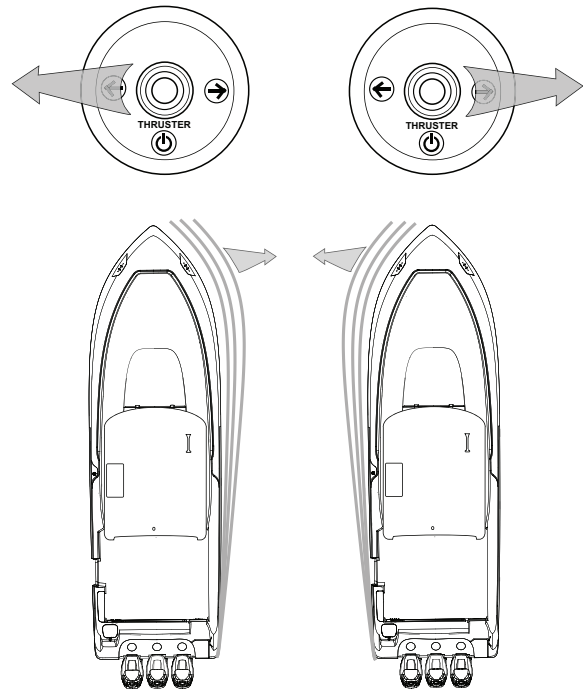

When the desired boat movement has been achieved return the joystick to the center position (spring return).

The bow thruster motor is equipped with an internal thermally activated breaker. The thermal breaker protects the motor from overheating. To avoid damage to the thruster, if the thermal breaker trips allow the unit to cool down before continuing operation.

NOTICE

If thruster is operated constantly for 3 minutes it will power down and panel will deactivate.

The system is designed to automatically power down after 20 minutes of no operation.

If thermal cut-out is activated all power to the controls is disabled. Wait for unit to cool down.

CAUTION

Do not move the joystick port to starboard in quick succession as this could damage the motor.

DANGER

DO NOT OPERATE THRUSTER OUT OF WATER

It is very dangerous to run the thruster out of the water, even for a few seconds. The motor will overspeed by 300%, causing damage to the unit and the propeller will cause serious damage or injury to whom or whatever comes in contact with it.

In addition, this action will void the warranty.

REFER TO THE BOW THRUSTER MANUFACTURER'S MANUAL IN YOUR OWNER'S PACKET FOR COMPLETE INSTRUCTIONS AND WARRANTY.

Section 2 • General Information

~~If it becomes necessary to tow your boat:~~

Towing, Docking and lifting

Bow Tow Eye (Option)

WARNING

PERSONAL INJURY HAZARD

Towing or being towed stresses the boat(s), hardware and lines. Failure of any part can seriously injure people or damage the boat(s).

DO NOT stand directly in line with the tow line. If it were to break, it would “snap Back” causing injury or damage to everything in its path.

The optional bow tow eye which is located on the hull, extreme front of the boat, is reinforced with a stainless steel backing plate located in the anchor locker.

In the event that it becomes necessary for you to have your boat towed, the U.S. Coast Guard or a private salvage company experienced in this type of operation are better equipped to perform the service.

Use another recreational boat only as a last resort. Doing so may cause damage to one or both boats due to operator inexperience or other conditions such as weather and/or current.

In addition, the pitch of most propellers on average recreational vessels is geared toward maximizing the speed of the vessel, not torque, thus making towing inefficient and stressful on the engine.

Another recreational boat may assist by standing by, and possibly keeping the disabled boat's bow at a proper angle until help arrives.

Bow Tow Eye (Option)

Fig. 2.35.1

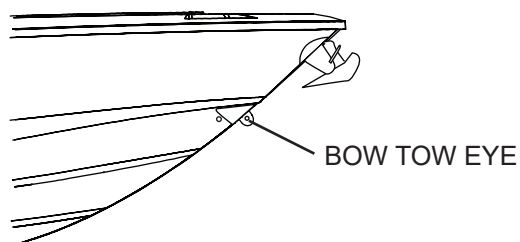

If possible, create a bridle with a line around the hull or superstructure or use spring lines to secure the towed vessel to the towing vessel (See below).

Either of these methods will distribute the load over a wide area. Be sure to use fenders or other chafe protection at the pressure points.

Methods of Towing

Fig. 2.35.2

BRIDLE

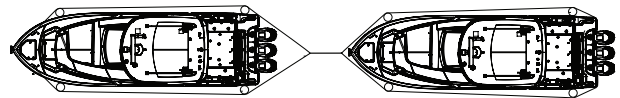

SPRING LINE

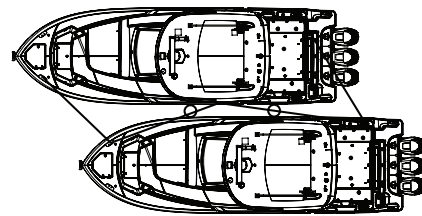

If using the bow eye to tow is the only option:

- Use double-braided or braid-on-braid line. Never use three-stranded twisted nylon; it has too much elasticity, can break and “snap back” causing severe injury or damage.
- Attach the tow line to the bow tow eye only. Do not attach the tow line to a cleat or deck rail.
- Have towing vessel move slowly to prevent strain on a slack line.
- Keep someone at the helm of the towed vessel to steer.
- Keep lines clear of propellers on both boats.
- Keep hands and feet clear of the other boat.
- Never hold a towline after it is pulled taut.

Docking

Your boat has nine 10 inch cleats, one located in the anchor locker, two located at the bow (P&S), two located amidship under the gunnel (P&S), two located in the aft cockpit under the gunnel (P&S) and two at the stern (P&S). The cleats are used to secure the boat to the dock. While loading/unloading or mooring, please learn the proper way to secure the boat and how best to use the mooring points of your boat.

⚠ WARNING

DO NOT use cleats to tow another boat.

Lifting

Do not use the bow eye for lifting the boat.

⚠ DANGER

Use only flat, wide belt-type slings and spreaders to lift the boat.

Lifting with bow and stern eyes will cause stress on the fiberglass & gel coat and may cause injury or death.

Whether you are lifting your boat out of the water for routine maintenance or long term storage, consider the following:

- If you are using a professional lifting service, it is prudent to check all credentials and ask for proof of insurance to protect your investment.

NOTICE

CLOSE THE A/C SEACOCK

Before removing your boat from the water be sure to close the A/C seacock. Failure to do so will cause an air lock in the line when the boat is returned to the water. The A/C system will then have to be primed before it will operate properly.

- Ensure that fish boxes and bilge are pumped out prior to lifting.
- Use a wide, flat, belt sling for lifting to minimize stress on the gunwales.
- Careful location of the sling is required. Do not place slings where contact with underwater fittings will occur.
- When secured on land, pull the garboard drain, ensure that motorwell drains and deck drains are free flowing and position the boat with the bow slightly higher than the stern so that any water which is allowed to accumulate in the cockpit, motorwell or bilge can easily drain from the boat.

Proper Lifting
Fig. 2.36.1

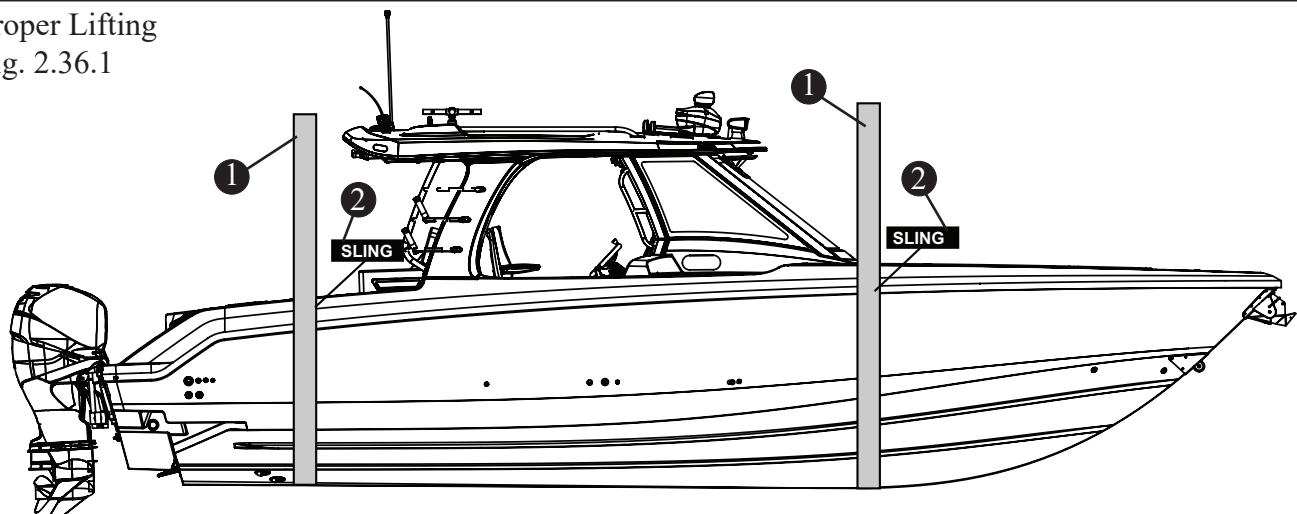

- ① WIDE, FLAT BELT SLING
- ② "SLING" LABEL LOCATED ON HULL (P&S)

Section 2 • General Information

Yacht Tender Package (Option)

If equipped, the yacht tender package consists of the following components (Figure 2.37.1):

- Clam shell covers over thru hull outlets to prevent water coming back into the boat.
- Ball valves on the port and starboard fish box outlets.
- High water float switch (Original equipment).
- Trumpet horn on hardtop (Original equipment).
- Strobe light added to hardtop.
- On/Off tow system switch.

The system is activated by a switch box located in the head cabinet below the sink (Figure 2.37.1).

Preparing Yacht Tender Package

- Close the fish box pump outlet ball valves in the aft bilge on both port and starboard side between the pumps and hull sides.
- Turn OFF all battery switches.

The power to the system is on the unswitched side of the house battery switch. The house battery switch can remain OFF while under tow except in the tow condition where vessel navigation lights are needed.

- Turn ON tow switch (Figure 2.37.1).
- Switch must be in the ON position while under tow. This provides power to the horn and the emergency strobe light on the hardtop. Both are activated by the high water float switch in the aft bilge (Figure 2.37.1).

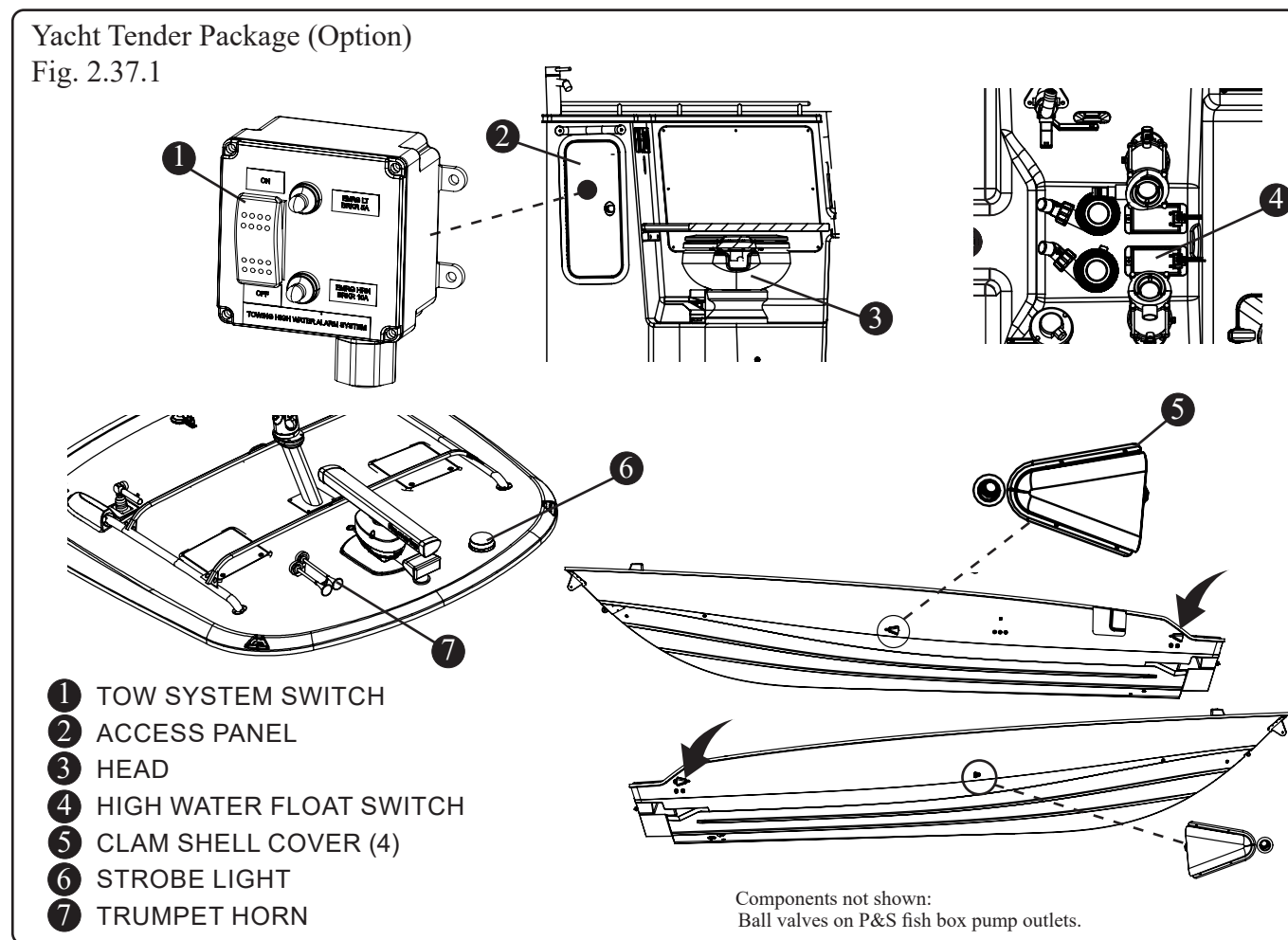

Section 2 • General Information

Out of Water Storage

If it becomes necessary to store your boat out of the water it is imperative that the boat is supported in a manner which will not damage the hull nor the keel.

Boston Whaler recommends that the hull be supported by a minimum of three keel stands. In addition, by a minimum of four side stands, two placed at port and two placed at starboard.

Specifications for keel stands (Figure 2.38.1) which meet the Boston Whaler requirements for support of your boats keel can be obtained by contacting your dealer or Boston Whaler.

NOTICE

The side stands are for stability only and are not intended to be load bearing.

CAUTION

In addition to the three keel stands, use a minimum of four side stands, two placed at port and two placed at starboard.

Use only the keel stands required by Boston Whaler for support of your boat out of water.

Specifications for the keel stands can be obtained from your dealer or Boston Whaler.

Out of Water Storage (Option)

In the event that required keel stands are not available see figure 2.38.1 for recommended out of water support of your boat.

Keel Stands
Fig. 2.38.1

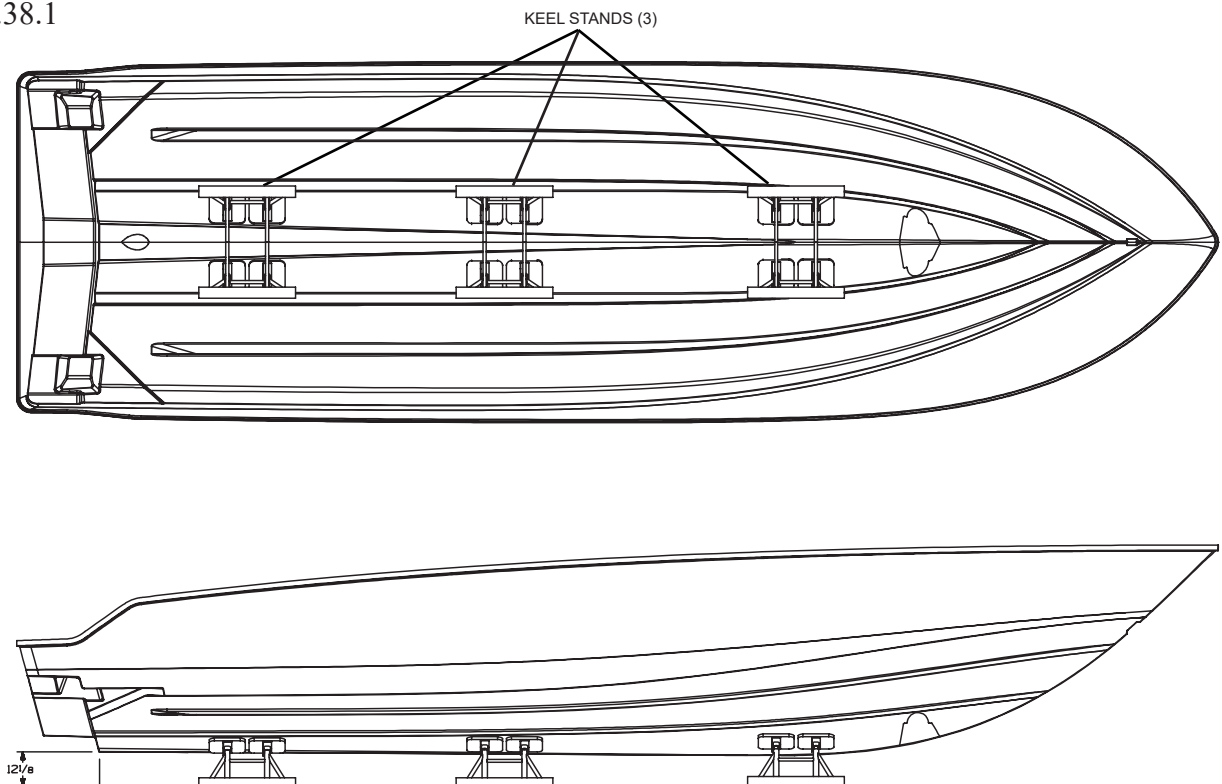

Section 2 • General Information

CAUTION

In addition to the five wood blocks, use a minimum of four side stands, two placed at port and two placed at starboard.

EACH WOOD BLOCK MUST CONTACT THE HULL FOR A MINIMUM LENGTH OF 8 INCHES.

NOTICE

The side stands are for stability only and are not intended to be load bearing.

Hull Support (Option)

Fig. 2.39.1

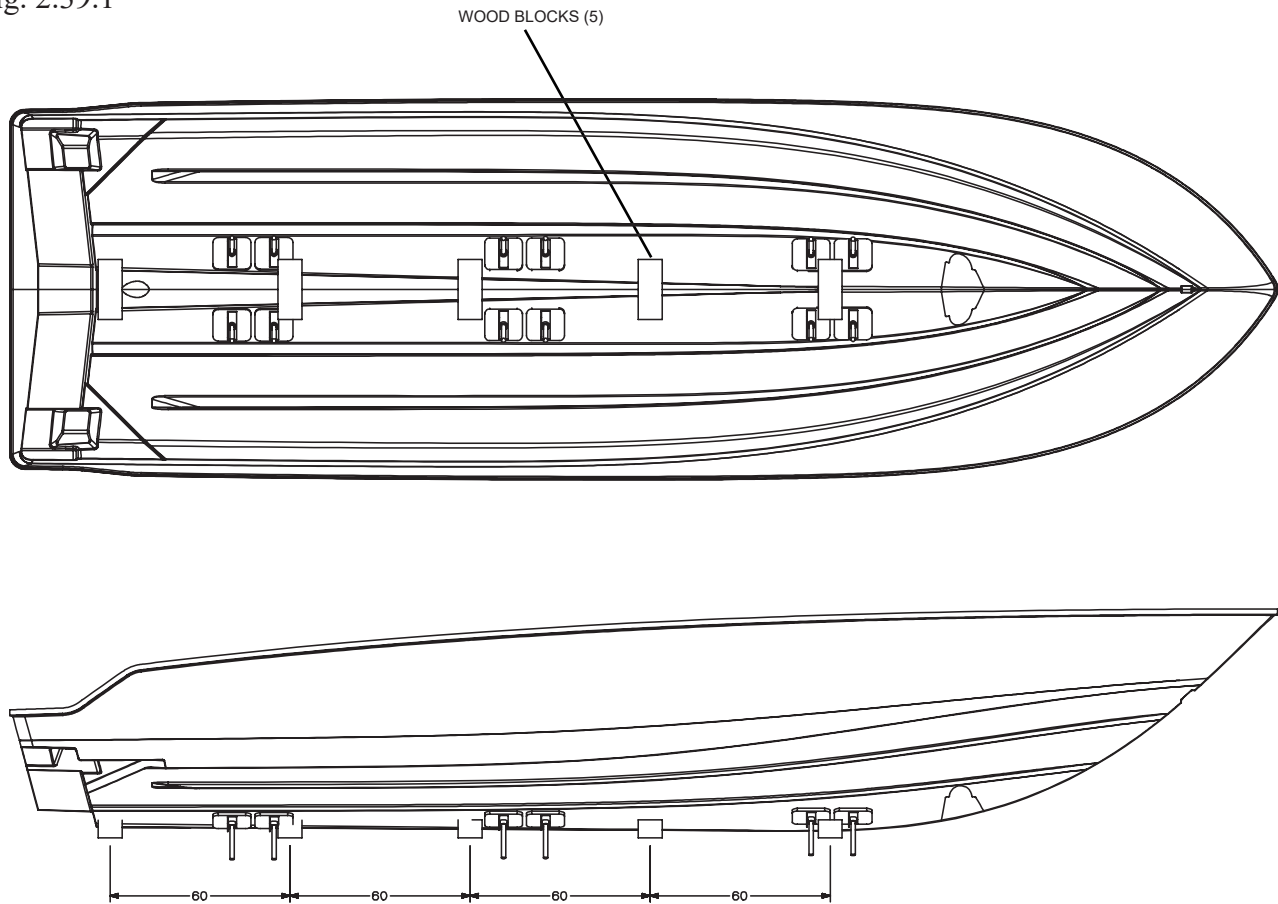

THIS PAGE INTENTIONALLY LEFT BLANK

Bilge Pumps

Your boat is equipped with three automatic bilge pumps, one forward, one aft and one high water emergency pump.

Each pump is activated automatically by an electric switch when the water in the bilge reaches a predetermined level.

By depressing the switch on the control station switch panel labeled FWD BILGE PUMP or AFT BILGE PUMP (see Figure 2.23.1) the operator can energize the pumps manually.

The aft pump discharges water overboard by way of a thru-hull fitting on the aft starboard hull. The high water pump discharges water overboard by way of a thru-hull fitting on the aft port hull. The forward pump discharges water overboard by way of a thru-hull fitting on the midship starboard hull (see Figure 2.7.1).

Bilge Pumps & Float Switch
Figure 3.1.2

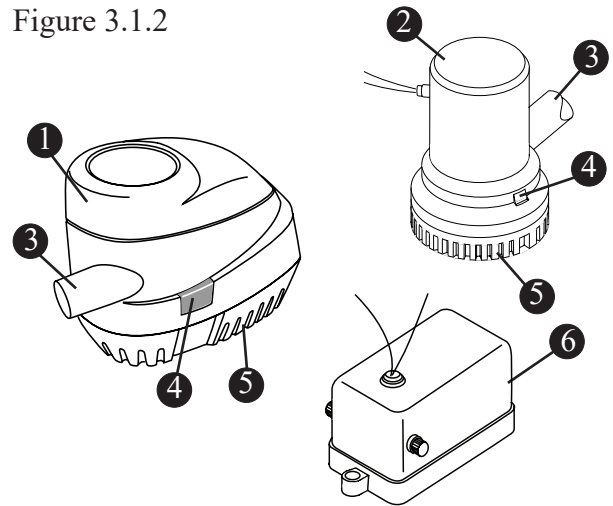

- 1 FORWARD PUMP 1100 GPH (4164 LPH)
- 2 AFT PUMPS 2000 GPH (7571 LPH)
- 3 WATER OUTLET
- 4 LOCK TAB
- 5 WATER INLET
- 6 FLOAT SWITCH

Bilge Pump Locations
Figure 3.1.1

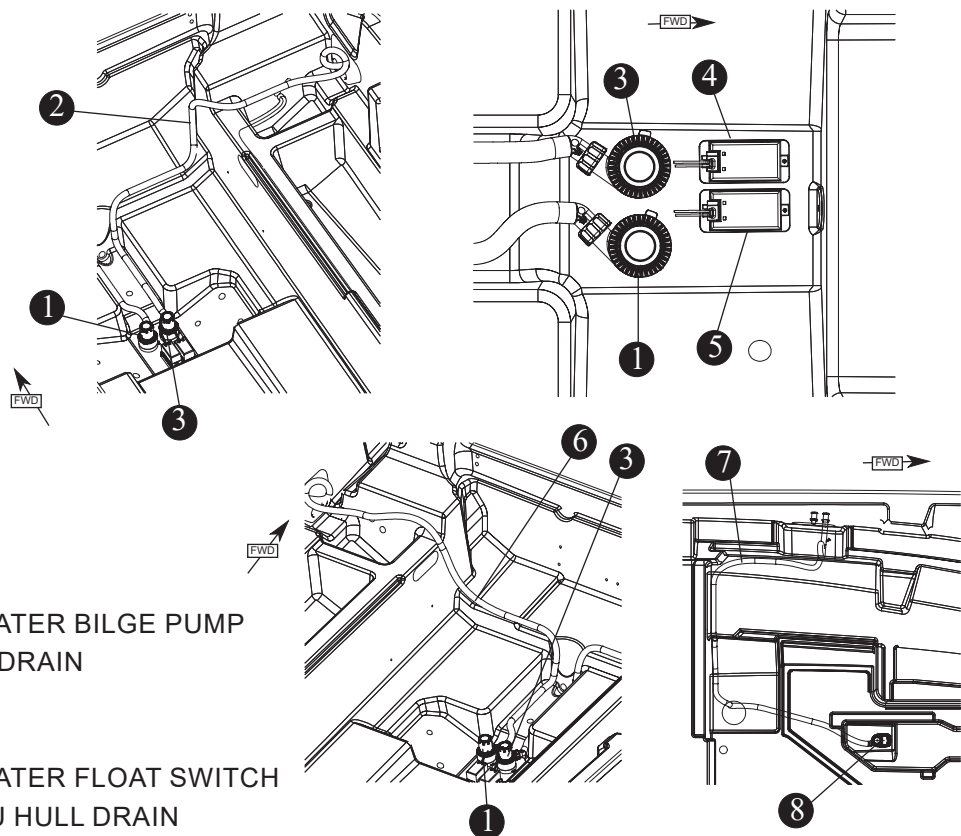

- 1 EMERGENCY HIGH WATER BILGE PUMP
- 2 TO PORT THRU HULL DRAIN
- 3 AFT BILGE PUMP
- 4 FLOAT SWITCH
- 5 EMERGENCY HIGH WATER FLOAT SWITCH
- 6 TO STARBOARD THRU HULL DRAIN
- 7 TO PORT THRU HULL DRAIN
- 8 FORWARD BILGE PUMP

Access to the Pumps

The aft pump and high water pump can be accessed through the equipment hatch in the aft cockpit floor. The forward pump can be accessed through a hatch in the floor of the cabin.

Bilge Pump Maintenance

To clean the pump strainer, depress the lock tabs on both sides of the pump and lift the pump motor (Figure 3.1.2).

If water does not come out of the discharge hose:

1. Remove the motor module to see if the impeller rotates with the power on.
2. Remove any debris that may have accumulated in the impeller section or strainer base.
3. Check hose and connection on hull side for

NOTICE

Inspect the bilge pump intakes frequently and keep them free of dirt or material which may impede the flow of water through the pump.

Float Switch

NOTICE

Inspect the bilge pump intakes frequently and keep them free of dirt or material which may impede the flow of water through the pump.

Frequently inspect the area under or around the float switches to ensure they are free from debris and gummy bilge oil.

To clean:

- Soak in heavy duty bilge cleaner for 10 minutes, agitating several times.
- Check for unrestricted operation of the float.
- Repeat the cleaning procedure if necessary.

Emergency High Water Bilge Pump

In the event that water has risen in the bilge sufficiently to activate the high water float switch, the emergency high water bilge pump will automatically begin to pump water out of the bilge. An audible alarm (loud buzzer) will sound at the helm and the “HIGH WATER” indicator light on the helm switch panel (see Figure 2.24.1) will be ON.

Take immediate action:

- Switch all bilge pumps ON.
- Use your radio to broadcast a PAN-PAN distress call.
- Turn OFF all AC and DC breakers before stepping into the water in the bilge.
- Determine the problem and take necessary action to stop the inflow of water.
- If after you determine your situation no longer requires assistance, you must cancel the PAN-PAN call.

NOTICE

After using the shower, run a gallon of clean water through the shower drain to flush out any soap residue.

Fuel and Oil Spillage

Regulations prohibit discharging fuel or oily waste in navigable waters. Discharge is defined as any action which causes a film, sheen or discoloration on the water surface, or causes a sludge or emulsion beneath the water surface. A common violation is bilge discharge.

Use rags or sponges to soak up fuel or oily waste, then dispose of them properly ashore. If there is a large quantity of fuel or oil in the bilge, contact a knowledgeable marine service to remove it. Never pump contaminated bilge discharge overboard.

Fill fuel tank less than rated capacity. Allow for fuel expansion.

GRAY WATER SUMP
Figure 3.3.1

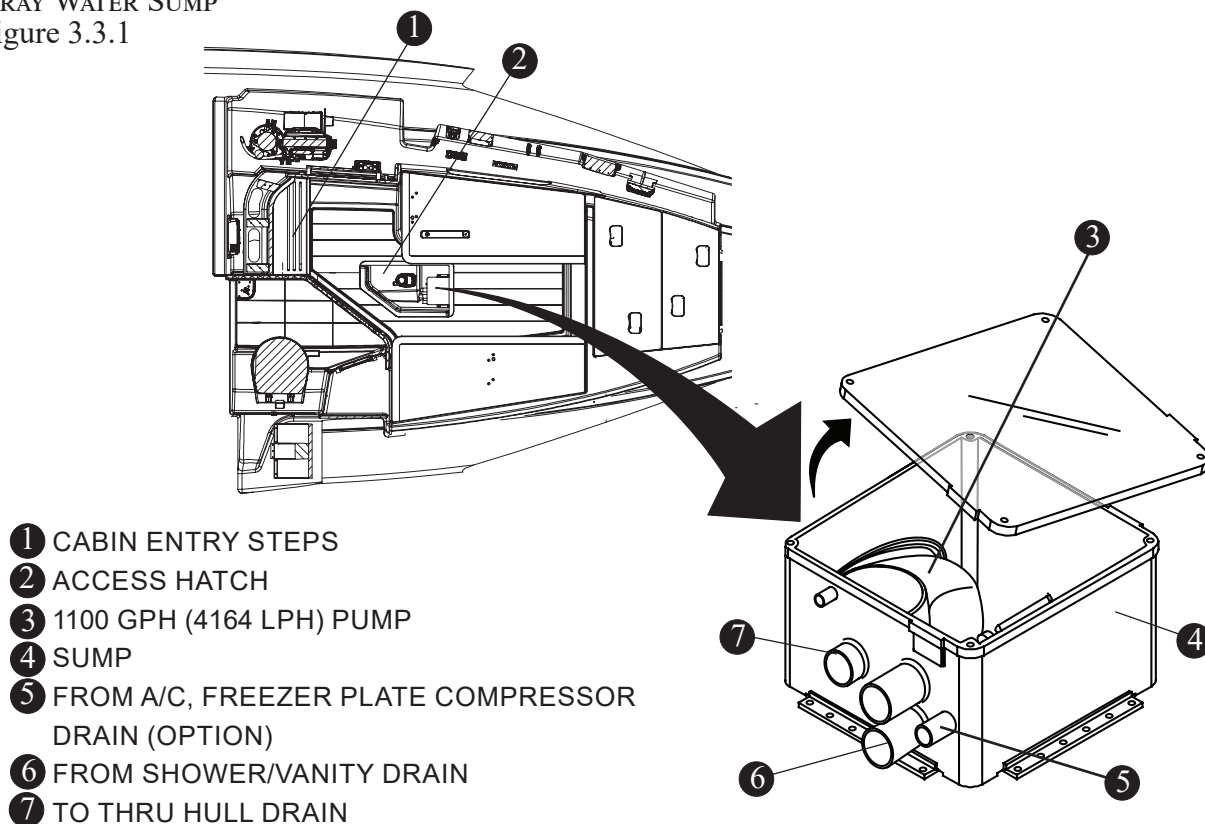

- ① CABIN ENTRY STEPS
- ② ACCESS HATCH
- ③ 1100 GPH (4164 LPH) PUMP
- ④ SUMP
- ⑤ FROM A/C, FREEZER PLATE COMPRESSOR DRAIN (OPTION)
- ⑥ FROM SHOWER/VANITY DRAIN
- ⑦ TO THRU HULL DRAIN

Gray Water Sump

Your boat is equipped with a gray water sump located under a hatch beneath the cushion of the bunk/settee in the cabin (see Figure 3.3.1).

Gray water from the shower and vanity, water from the water heater drain and the storage garage drain collect in the sump.

The sump contains its own automatic pump. When there is enough water in the sump to raise the float switch and start the pump the water is discharged through the thru hull drain (see Figure 2.6.2).

Maintenance

Periodically remove the clear cover and check the pump and float switch for proper working order. Clean out any obstructions which may inhibit the pump from performing correctly.

Fuel System

⚠ CAUTION

- Oil and fuel spills can be dangerous and can subject offenders to severe penalties
- Leaking fuel is a fire and explosion hazard, inspect the system regularly. Examine fuel tanks and exposed lines for leaks and corrosion.

This system has been designed to meet the EPA regulations using certified components to limit the fuel vapor emissions.

Your fuel system provides the following benefits:

- Automotive style refueling, automatic nozzle shut-off, fuel nozzle retention. This system sends a signal to the pump nozzle to

shut off before there is any spit-back or well-back through the fill opening.

- Overfill protection is included with each system, reducing the possibility of accidental fuel spills.
- Reduce hydrocarbon emissions through the use of a specially designed fuel fill. This fuel fill has a permanently attached cap with a positive closure mechanism with an audible click, to let you know when it is sealed.

Fuel tank

Your boat is equipped with a low permeation aluminum fuel tank with a usable fuel capacity of 385 gallon (1457 L). The usable capacity of the fuel tank is different from the tank capacity marked on the tank from the manufacturer. The difference is the non-usable portion of the tank which results from the

Fuel Tank
Figure 3.4.1

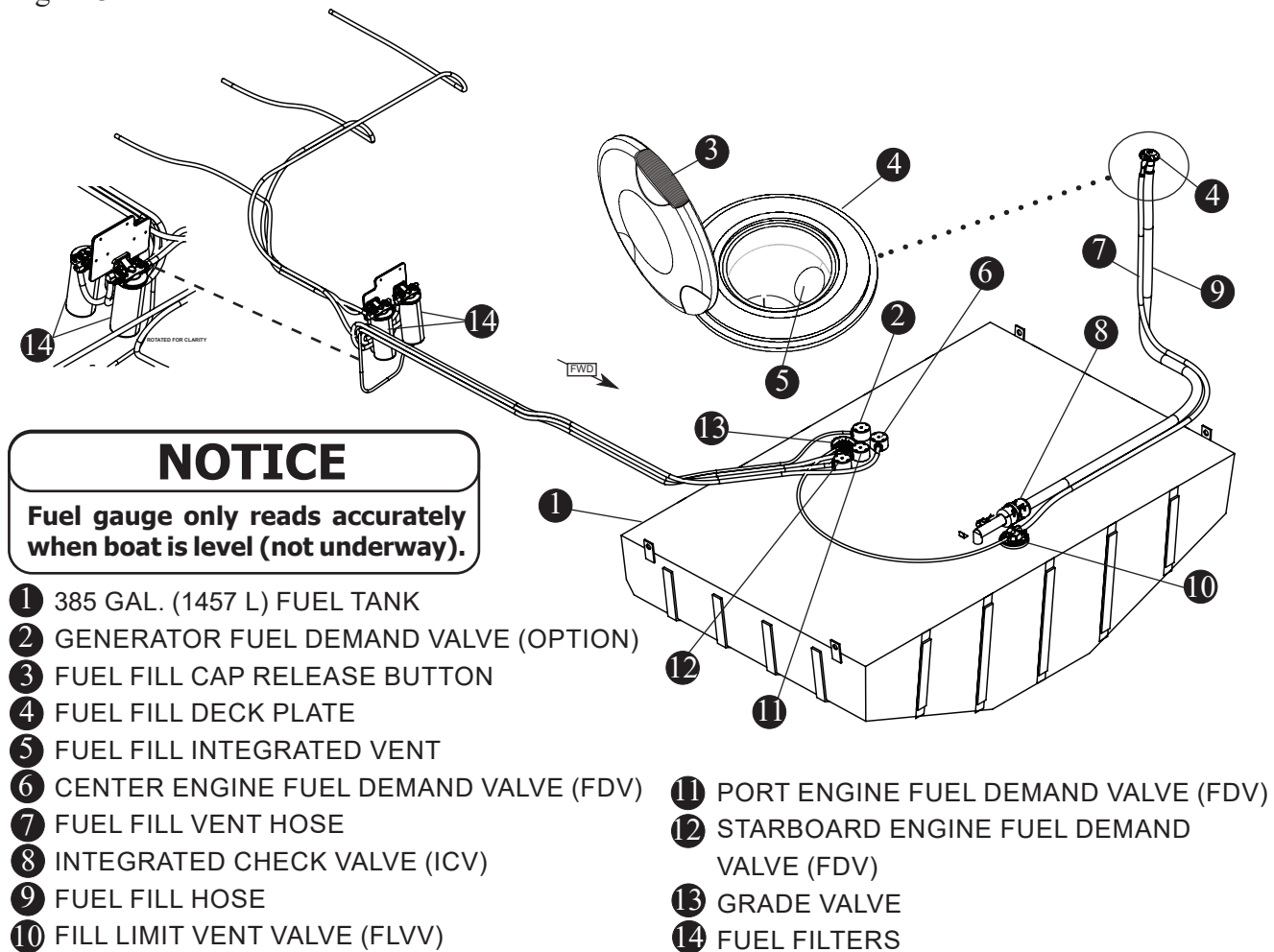

CAUTION

Use of improper fuel can seriously damage your engine. Engine damage resulting from use of improper fuel is considered misuse of engine and will void the warranty. Follow engine manufacturer's recommendations regarding the types of fuel and oil to use.

NOTICE

It is your responsibility to read and understand the engine manufacturer's manual in your owner's manual packet for complete fuel and fueling information and warnings.

fuel in the tank that is below the pickup tube and the ullage area that has been incorporated into your tank. It is recommended that you follow all instructions regarding the filling of fuel tanks. Please take time to read and understand all the fuel related information and warnings regarding gasoline and your boat, in the engine owner's packet.

Fuel tanks with levels less than 1/4 full can cause engine stalling problems due to fuel starvation or by allowing sediment and dirt to enter the fuel supply lines. Keep the tank full and monitor the fuel level often to prevent this from happening.

Fuel Vent

The fuel tank vent is integrated into the fuel fill deck fitting (see Figure 3.4.1). The VaporTec fuel pressure management system, (fuel fill deck fitting, integrated check valve, fill limit vent valve, grade valve), ensures that the fuel system constantly maintains proper vapor pressure in all situations. This eliminates any unintended pressure which can seriously damage a boat or engine. The vent serves as an over pressure/vacuum release with anti-surge and flame/spark arresting protection. The fuel vent system also plays an important role in controlling the "FULL" level of fuel with the use of the FLVV (Fill Limit Vent Valve). Grade Valves have been added to the tank which allows proper ventilation of the tank when the boat is stored, or trailered, on a moderate incline, without fuel seepage.

Fuel Distribution System

The fuel is delivered from the tank to the engine through the Fuel Demand Valve (FDV), anti-siphon valve, and the fuel line. The FDV prevents the built

up pressure inside the tank from being transferred to the engine while still allowing fuel to flow as the engine requires it for operation. The anti-siphon valve is a safety feature designed to prevent the fuel from siphoning out of the tank if the fuel line were to be cut or broken below the level of the fuel in the tank. In this case, some fuel would leak from the line, but would not allow the entire contents of the tank to siphon into the boat.

Filling The Tank

WARNING

The fuel system on this vessel complies with all applicable ABYC standards. Fueling station pump flow rates that exceed 18 gallons (68 liters) per minute may damage system components and cause fuel leakage into the vessel.

This fuel system is designed to automatically shut off the fuel nozzle when the tank is full, similar to an automotive fuel system. The tank is filled when the fuel fill nozzle has shut itself off the second time. The SecureStop automatic fuel shut off system (Fuel Fill Deck Fitting, Integrated Check Valve, Fill Limit Vent Valve), guarantees the boater a clean a trouble-free fill -up. Attempting to fill the tank past this point may cause some of the components to not function properly, or malfunction.

WARNING

The use of a portable fuel tank to fill your boat's tank can result in overfilling and circumvent the safety features designed into your tank.

WARNING

The modification of any of the fuel system components or the replacement of these components with unauthorized parts may result in over-pressurization of the fuel system and circumvent the safety features designed into your tank.

NOTICE

Keep records of the fuel capacity and consumption of your boat. Drastic changes in consumption and mileage may indicate a problem.

REFER TO THE ENGINE MANUFACTURER'S MANUAL IN YOUR OWNER'S MANUAL PACKET FOR COMPLETE INSTRUCTIONS AND WARRANTY.

Static Electricity and the Fuel System

There is a danger that static electricity can ignite gasoline vapors that have not been ventilated outside an enclosed area. Use extreme caution when fueling your boat from a source outside the regular venues, (e.g. marinas, fuel service stations).

Your boat's bonding system protects it from creating and discharging static electricity. Your boat must be in contact with the water or a land-based grounding system while fueling.

Your boat has safety features that can be circumvented by not adhering to standard fueling practices. The following suggestions will help keep you safe from static electricity while refueling your boat.

- **NEVER** fuel your boat in unsafe conditions such as suspended on a sling or in a situation that increases the likelihood of static discharge.
- **NEVER** use homemade containers to fill your fuel tanks.
- Fuel carried on-board outside of a fixed fuel system should be stored in an approved container or in a portable tank such as provided for outboard engines and be stowed safely outside of the engine or living compartment(s).

There is a danger that static electricity can ignite gasoline vapors that have not been ventilated outside an enclosed area. Use extreme caution when fueling your boat from a source outside the regular venues, (e.g. marinas, fuel service stations).

Your boat's bonding system protects it from creating and discharging static electricity. Your boat must be in contact with the water or a land-based grounding system while fueling.

Your boat has safety features that can be circumvented by not adhering to standard fueling practices. The following suggestions will help keep you safe from static electricity while refueling your boat.

- **NEVER** fuel your boat in unsafe conditions such as suspended on a sling or in a situation that increases the likelihood of static discharge.
- **NEVER** use homemade containers to fill your fuel tanks.
- Fuel carried on-board outside of a fixed fuel system should be stored in an approved container or in a portable tank such as provided for outboard engines and be stowed safely outside of the engine or living compartment(s).
- Shut down the engine, motors and fans prior to taking on fuel. Any ignition sources should be extinguished before filling the fuel tanks.
- Close all ports, windows, doors and hatches.
- Fueling should never be done at night except in well-lighted areas.
- Always keep the fuel nozzle in contact with the fuel fill plate or the edge of the fuel tank opening throughout the filling process.
- Allow areas where gasoline vapors could collect to be ventilated before starting the engine.
- Wipe any spillage completely and dispose of rags or waste on shore.
- Secure the fuel cap tightly.
- Portable tanks should only be filled while on the ground, never on board the boat.

DANGER

Static electricity can ignite gasoline vapors causing serious injury/death and/or destruction of property.

Check for leaks in tubing, connections and hoses. Correct the cause of any leaks and ventilate the area to insure that no fumes remain, prior to energizing any electrical equipment and/or starting the engines.

Ethanol-Blended Fuels

Ethanol is an oxygenated hydrocarbon compound that has a high octane rating and therefore is useful in increasing the octane level of unleaded gasoline.

NOTICE

The use of improper gasoline or additives can damage your fuel system and is considered misuse of the system. Damaged caused by improper gasoline or additives will not be covered under warranty.

The fuel-system components of your Mercury engine(s) have been tested to perform with the maximum level of ethanol-blended gasoline (10% ethanol) currently allowed by the EPA in the United States.

Special precautions should be considered with the use of fuel containing ethanol in your system. Fuels with ethanol can attack some fuel-system components, such as tanks and lines, if they are not made from acceptable ethanol-compatible materials. This can lead to operational problems or safety issues such as clogged filters, leaks or engine damage.

Your boat was manufactured, and shipped from the factory, with ethanol-compatible materials. Before introducing gasoline with ethanol into your fuel tank, ask your dealer if any components have been added or replaced that are not recommended by Boston Whaler, Mercury or may not be ethanol-compatible.

Keep Tank Full

It is best to maintain a full tank of fuel when the engine is not in use. This will reduce air flow in and out of the tank due to changes in temperature as well as limiting exposure of the ethanol in the fuel to humidity and condensation.

Phase Separation

Humidity and condensation create water in your fuel tank which can adversely effect the ethanol blended fuel. A condition called phase separation can occur if water is drawn into the fuel beyond the saturation

point. The presence of water in the fuel beyond the saturation level will cause most of the ethanol in the fuel to separate from the bulk fuel and drop to the bottom of the tank, significantly reducing the level of ethanol in the fuel mixture in the upper level (phase). If the lower level (phase), consisting of water and ethanol, is deep enough to reach the fuel inlet, it could be pumped directly to the engine(s) and cause significant problems. Engine problems can also result from the reduced ethanol/fuel mixture left in the upper phase of the tank.

Additives

There is no practical additive known that can prevent or correct phase separation. The only solution is to keep water from accumulating in the tank.

If phase separation does occur, your only remedy is to drain the fuel, clean and dry the tank completely and refill with a fresh, dry load of fuel.

Fuel Filters

Mercury already provides the appropriate level of filtration to protect the engine from debris. The addition of another *in-line* filter to the system will create a possible flow restriction that can starve the engine(s) of fuel.

Fuel/water Separator

The fuel/water separator has been determined to be within Mercury specifications and will not restrict the flow of adequate fuel to the engine(s).

Maintenance

Periodically inspect for the presence of water in the fuel tank. If any is found, all water must be removed and the tank completely dried before refilling the tank with any fuel containing ethanol.

Storage

Long periods of storage and/or non-use, common to boats, create unique problems. When preparing to store a boat for extended periods, of two months or more, it is best to completely remove all fuel from the tank. If it is not possible to remove the fuel,

CAUTION

The use of fuels containing ethanol higher than 10 percent (E-10) can damage your engine and/or fuel system and will void the warranty.

E85 fuels could seriously damage your engines and must never be used.

maintaining a full tank of fuel with a fuel stabilizer added to provide fuel stability and corrosion protection is recommended.

- Add fuel stabilizer/treatment at manufacturers recommended dosage.
- Run engine(s) for 10 minutes.
- Shut OFF fuel valve.
- Allow engine to run until it stops.
- Top off fuel tank, leaving space for expansion. Do not fill to point of overflow.
- Do not cap the tank vent.

Example of Phase Separation

Figure 3.8.1

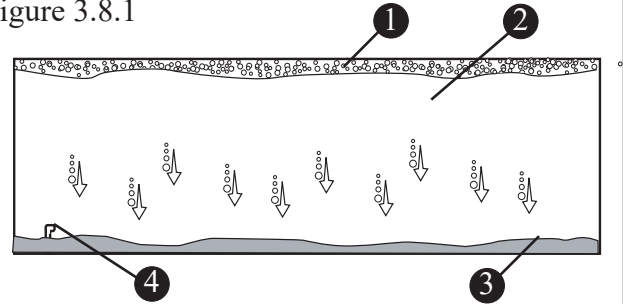

- 1 CONDENSATION
- 2 UPPER PHASE (WATER+FUEL+ETHANOL)
- 3 LOWER PHASE (WATER+ETHANOL)
- 4 FUEL INLET TO ENGINE

A partially full tank is not recommended because the void above the fuel allows air movement that can bring in water through condensation as the air temperature moves up and down. This condensation could potentially become a problem.

REFER TO THE ENGINE MANUFACTURER'S MANUAL IN YOUR OWNER'S MANUAL PACKET FOR COMPLETE INSTRUCTIONS AND WARRANTY.

Power Steering

The Verado four-stroke engines use an enclosed hydraulic pump unit. The pump is electrically operated to provide hydraulic pressure to the steering system. The pump is located in the aft of the bilge and can be accessed by removing the access hatch behind the aft bench seat.

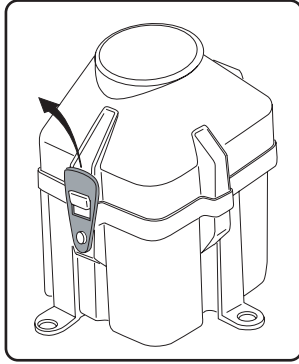

- Remove the pump cover by pulling up and out on the locking tabs on the sides of the unit.

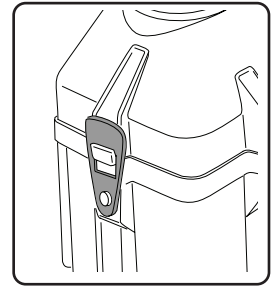

Filling and Maintenance

The system is virtually maintenance free, aside from regular fluid checks and visually inspecting the outside of the unit for signs of leaks or damage.

- Unscrew the cap and check the fluid level in the reservoir, fill only with SAE 0W-30 Full Synthetic Power Steering Fluid if necessary.
- Replace cap and cover.

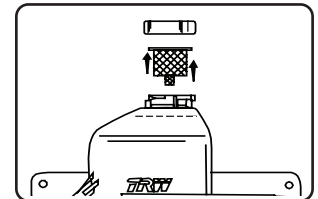

NOTICE

Ensure that cover is properly seated to prevent intrusion of water into the pump enclosure.

Check the fluid level before each trip. Proper maintenance of this system will ensure worry-free

Power Steering
Figure 3.9.1

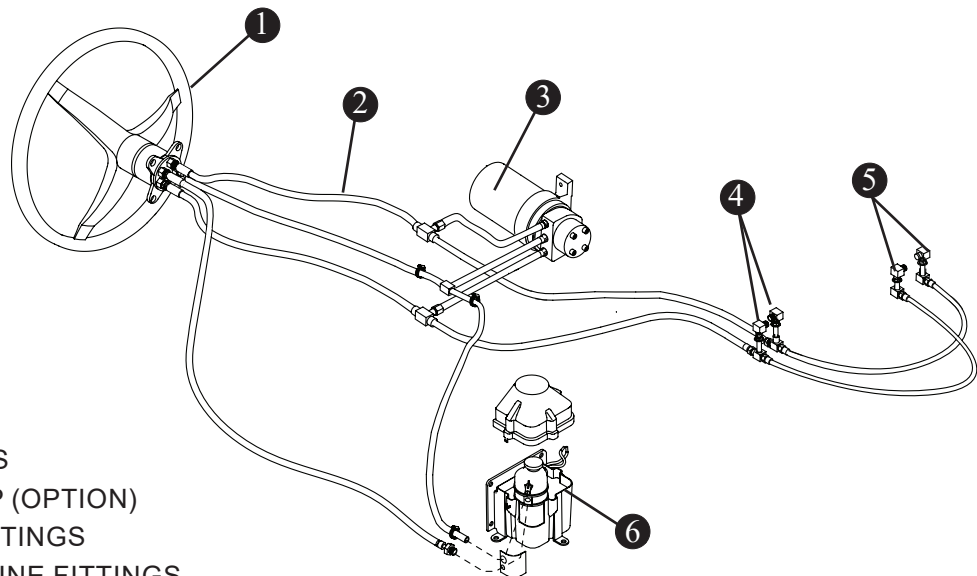

- ① HELM
- ② HYDRAULIC LINES
- ③ AUTOPILOT PUMP (OPTION)
- ④ PORT ENGINE FITTINGS
- ⑤ STARBOARD ENGINE FITTINGS
- ⑥ POWER STEERING PUMP

Chapter 3 • Systems Overview & Operation

usage for the life of your boat. Steering system integrity is imperative when engaging in recreational water activities. Special care and attention must be taken to ensure proper performance of the steering system and should include the following:

- After the first few hours of operation and at regular intervals, check all fasteners and the complete steering system for security and integrity.
- Inspect for corrosion. Any part affected by corrosion must be replaced.
- When replacing parts, self locking hardware must be used.
- Check the fluid level in the helm pump unit.
- Lubricate slides on the engine cylinders.

All steering systems whether mechanical or hydraulic require regular inspections, periodic adjustment and occasional replacement may be necessary.

REFER TO THE ENGINE MANUFACTURER'S MANUAL IN YOUR OWNER'S MANUAL PACKET FOR COMPLETE INSTRUCTIONS AND WARRANTY.

Starting/Stopping the Engines

CAUTION

Never start or operate your engines (even momentarily) without water circulating through all the cooling water intake holes in the gear case to prevent damage to the water pump (running dry) or overheating of the engine.

- Operator should know boating safety, safe navigation, and boat operating procedures.
- Make sure that the lower unit of the engine is in the water.

- Make certain the gear shift/throttle control is in the neutral position. (The engine will not start if the control lever is in any other position than NEUTRAL)
- Be sure the engine stop switch (See figure 1.16.1) is in the “RUN” position.

Engine Starting

The engine battery switches and master ignition key switches are located at the DC distribution panel (see Figure 4.8.1) behind an access door midship on the port gunnel. The switches must be turned on to activate the system.

NOTICE

Engines cannot be started from this location.

NOTICE

The gear shift/throttle control levers will not allow engine starting if the control levers are in any other position than neutral.

- Turn engine battery switches ON.

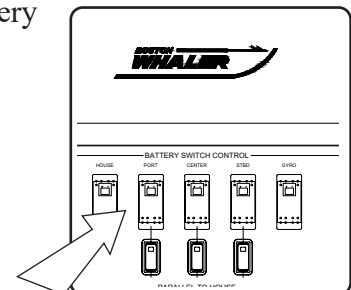

- Turn the master ignition key switches ON (clockwise).

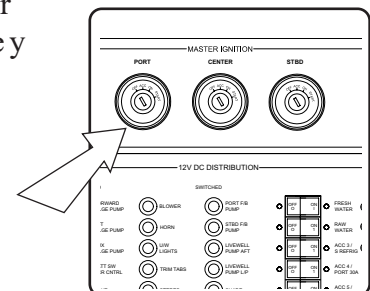

Master Key Switches
Figure 3.11.1

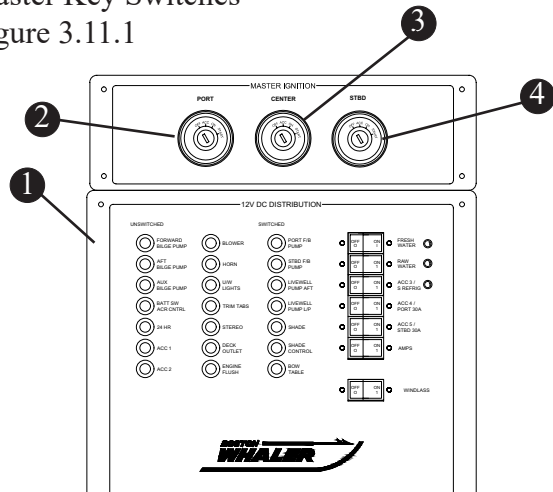

- ① DC DISTRIBUTION PANEL
- ② PORT ENGINE KEY SWITCH
- ③ CENTER ENGINE KEY SWITCH
- ④ STARBOARD ENGINE KEY SWITCH

- Be sure the throttle control levers are in the NEUTRAL position.

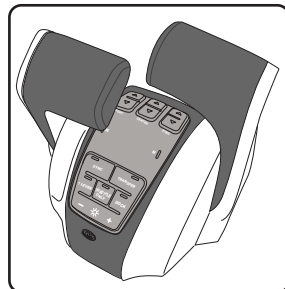

- Press START/STOP button(s) for the appropriate engine.

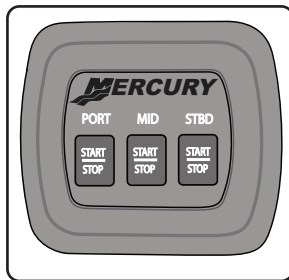

The neutral (N) lights located on the throttle remote pad will become illuminated once the engines are started and communicating with the throttle control.

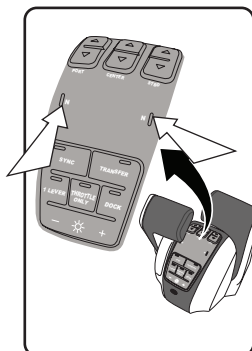

Parallel Switching

In the event the battery for a particular engine is not sufficiently charged to start the engine depress the “Parallel to House” switch for the particular engine. The engine will then be connected to the house batteries which will initiate ignition.

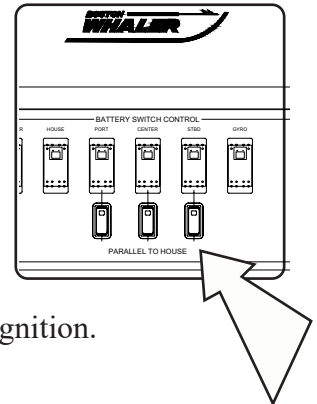

Warming Up the Engines

The “THROTTLE ONLY” button on the throttle control pad allows the operator to increase engine RPM for warm-up without shifting the engines into gear.

- Be sure that the gear shift and throttle control levers are in the neutral position.

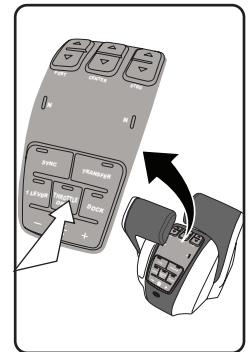

- Press and hold the “THROTTLE ONLY” button while moving the control handle ahead to the forward position.
- Hold in the button until the horn sounds twice and the neutral lights start flashing. The flashing lights indicate that throttle only is engaged.

- Advance the control handles to increase engine RPM.

NOTE: Engine RPM is limited to prevent engine damage.

- To disengage, return the control handles back to the neutral position.

The warm-up mode can be re-activated by turning the engines off and re-starting.

Engine Stopping

- Be sure that the gear shift and throttle controls are in the neutral position.

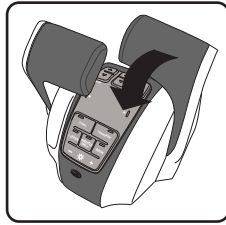

- Press the start/stop button on the ignition pad for the appropriate engine.

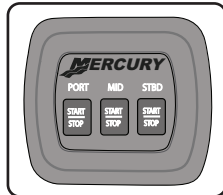

REFER TO THE OWNER'S MANUAL IN YOUR OWNER'S MANUAL PACKET FOR COMPLETE INSTRUCTIONS AND WARRANTY.

Theft Deterrent System/Whaler Watch (Option)

If equipped, the TDS system's two-piece fob carries a transponder that interfaces with the docking station. This system is designed to deter theft 24/7/365 by limiting engine RPM. The antenna in the docking station and the fob transmit radio signals, which send messages to the system computer. These messages create a direct communication link to the engine computer via Mercury's proprietary controlled area network messaging system.

In the event that the fob is missing or not the correct one, Mercury TDS allows you to start the engine but limits RPM and performance while still allowing slow speed operation. Until the system is fully engaged with the fob fully inserted in the docking station, the engine will only operate at this reduced power range and performance will be restricted. Once TDS is deactivated with the fob, the engine will perform at normal operating ranges.

NOTICE

If key fob is missing the engines can still be started. However, engine power will be limited to low engine RPM.

Starting the Engines w/TDS Whaler Watch

TDS Docking Station and Key Fob
Figure 3.12.1

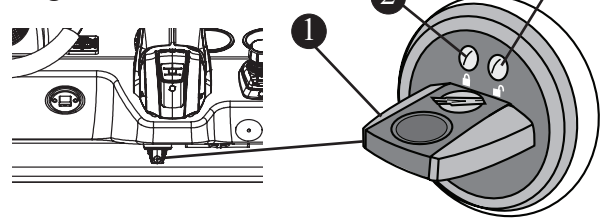

- 1 FOB
- 2 RED LIGHT
- 3 GREEN LIGHT

- Insert the fob into the docking station.

- Switch ON battery for each engine.

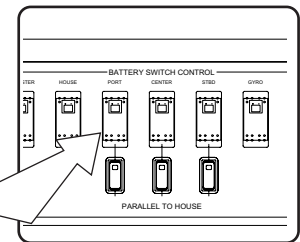

- Turn ignition key to the ON position (clockwise).

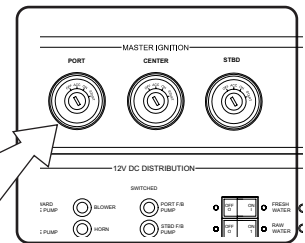

The red light will come on for a moment followed by the green light. The system is now unlocked and you may start the engines using normal procedure.

- Be sure the throttle control levers are in the NEUTRAL position.

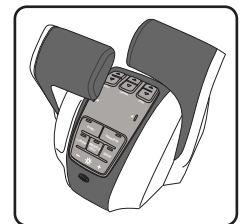

- Press START/STOP button(s) for the appropriate engine.

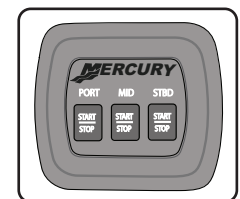

REFER TO THE OWNER'S MANUAL IN YOUR OWNER'S MANUAL PACKET FOR COMPLETE INSTRUCTIONS AND WARRANTY.

Fresh Water System

The freshwater system on your boat includes: one pump, a 45 gal (170 L) fresh water tank and plumbing connections for water service to the head, vanity sink, prep station sink, transom shower, prep station shower and anchor locker.

Filling the Tank

The water tank can be filled through the water fill deck plate located on the port transom (see Figure 2.9.1).

Fill the tank only from a source known to provide

Fresh Water System

Figure 3.13.1

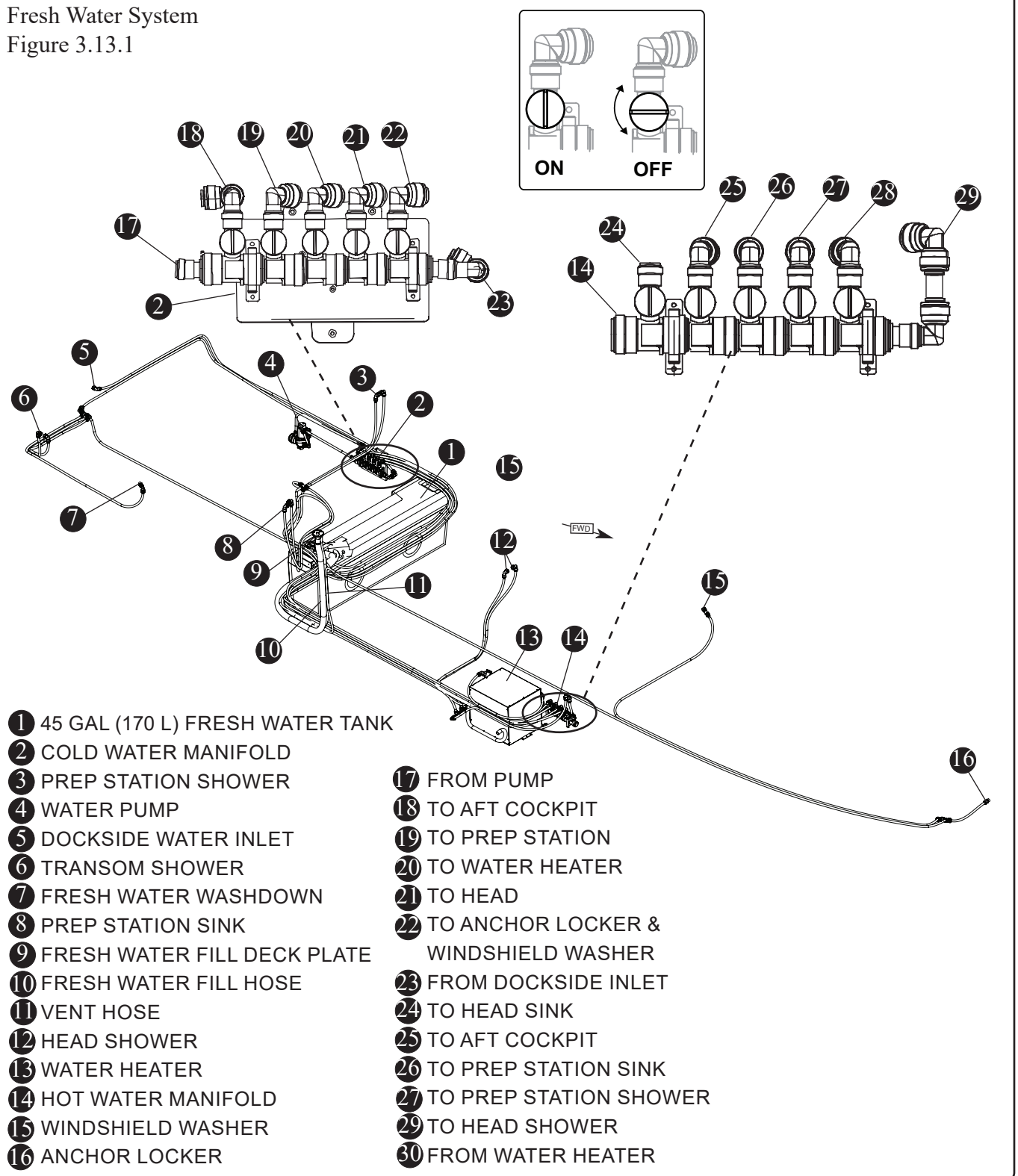

NOTICE

- **Be sure to fill the water tank from a source known to provide safe, pure drinking water.**
- **If you do not use the freshwater system for long periods of time or only use it seasonally it is recommended that you follow the disinfecting practice before using it.**

safe, pure drinking water. Use only a plastic hose to fill the water tank. Using a rubber hose can give the water a disagreeable taste.

The hose should be dedicated to filling use only and should be stored in a clean, dry place. It is a good practice to cover the ends of the hose to ensure the inside stays clean.

Before you fill the freshwater system it is vital that it be properly disinfected. Ask your dealer if this has been done. The following procedure is recommended to disinfect the freshwater system:

1. Flush the entire system thoroughly by allowing potable water to flow through it.
2. Drain the system completely.
3. Fill the entire system with an approved disinfecting solution (check with your dealer for recommendations) and follow the method prescribed by the manufacturer.
4. After disinfecting, drain the entire system.
5. Flush the entire system thoroughly several more times with potable water.
6. Now the system is ready for use, fill with potable water.

This should be done annually or before using the system if it has been laid up for an extended amount of time.

Freshwater Pump

Your boat has a fresh water pump located in the port side bilge area aft of the battery trays. To access the pump, lift the equipment hatch in the aft cockpit deck.

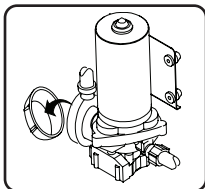

To operate the system, turn ON the “FRESH WATER” breaker located on the DC Breaker Panel located on the port gunnel.

When activated, the freshwater pump draws water from the water tank and provides pressure to the entire freshwater system.

Periodically check the hoses and connections for leaks and/or loose fittings. A loss of pressure will result in low water flow.

Deck Showers

Your boat is equipped with two freshwater deck showers, one is located on the starboard side, aft of the transom door and the other is located on the aft port side of the prep station.

The shower hose units are pressurized by the fresh water pumps and the spray head is activated by twisting the center of the unit.

Deck Shower
Figure 3.14.1

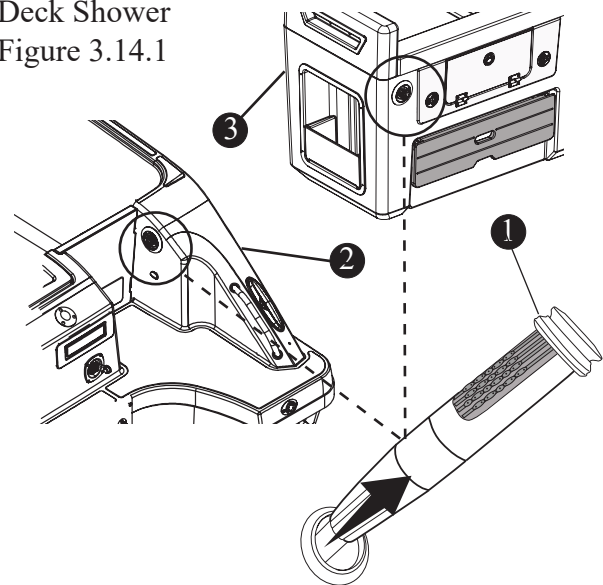

- 1 EXTENDABLE SHOWER HEAD
- 2 STARBOARD TRANSOM
- 3 PREP STATION

Anchor Locker Washdown

For your convenience, there is a fitting located at the bow in the anchor locker which allows for the connection of a common garden hose. This connection allows for the use of fresh water at the bow of your boat. It is important that the cap which is tethered to the connection be screwed onto the fitting when it is not being used.

The “FRESH WATER” switch located on the bait prep station switch panel must be ON to operate the anchor locker freshwater washdown.

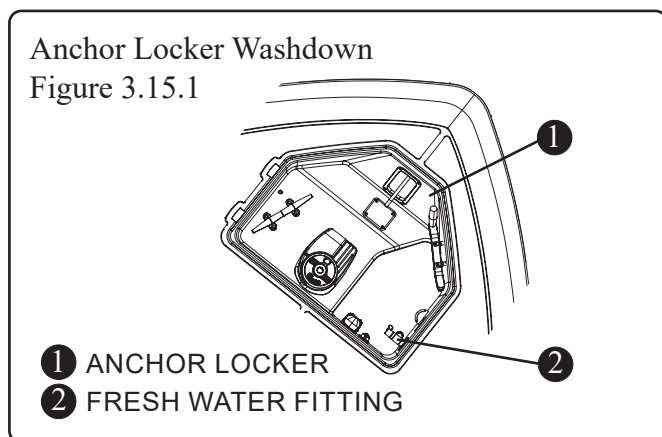

Water Heater

NOTICE

Make sure the fresh water tank is full before operating the water heater. Operating the water heater empty will cause damage to the system.

Operation

Make sure the “FRESH WATER” switch on the DC Breaker Panel located on the port gunnel is “ON” before energizing the water heater.

Turn “ON” the “WATER HEATER” switch on the AC Main Distribution Panel located on the port aft wall of the cabin. Once both the “FRESH WATER” switch and the “WATER HEATER” switches are “ON” the system can be utilized.

NOTE: If the water heater has not been used for some time it will take approximately 20 minutes for the water to heat.

! CAUTION

SCALDING INJURY - Turn OFF the water heater and wait for the water in the storage tank to cool before opening the drain valve to flush the tank.

! WARNING

Hydrogen gas may form in the tank if the system has not been used for more than two weeks. DO NOT smoke or have any flame near an open faucet.

NOTICE

The water heater is equipped with a temperature and pressure relief valve that complies with the standard for Relief Valves & Automatic Gas Shut off Devices for Hot Water Systems, ANSI Z 21.22

Tempering Valve

A tempering valve is installed on the hot water outlet of the water heater (Figure 3.15.2) to reduce the risk of scalding. The valve is set at it’s lowest temperature (100°F) at the factory. The water temperature can be adjusted up to a maximum of 130°F by turning the valve counterclockwise until the water temperature reaches your desired limit.

Water Heater
Figure 3.15.2

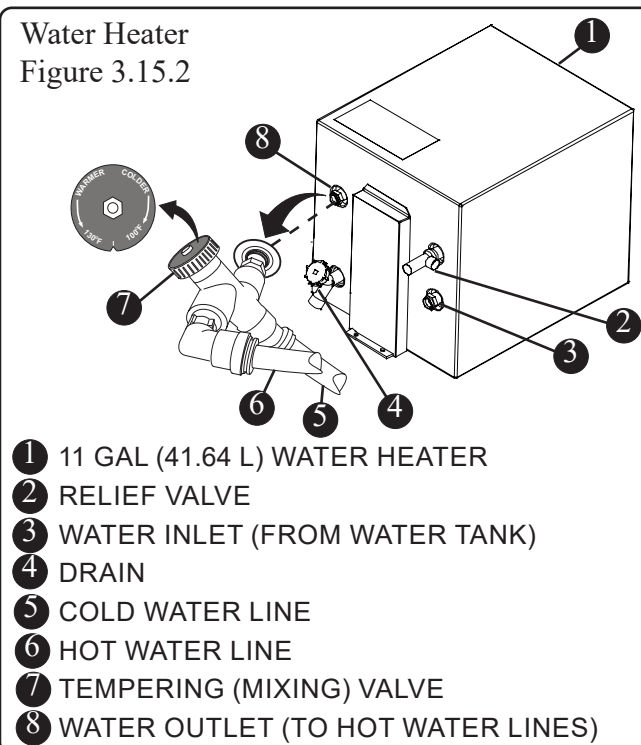

Maintenance

The water heater connections will need to be inspected regularly. Access to the water heater can be made through the back wall of the hanging closet in the forward console. If you notice any leaks around the water heater call your dealer.

Manually operate the pressure relief valve at least once a year. This must be done when the water in the storage tank is cool.

The system must be flushed several times per year; which will prolong the life of the system. There may be times that you will notice an odor coming from the water system. There is a protective cladding in the tank that protects it from corrosion. The electro-galvanic action of the cladding material releases hydrogen from the water. If sulfur or any of its combinations are present in the water the two will combine and produce hydrogen sulfide. This compound will produce a “Rotten Egg Odor”. Hydrogen sulfide can also be present in your freshwater supply. It is the product of the decay of animal matter and as little as 1 mg/liter can cause a perceptible odor.

Make certain that the system is completely drained before laying up for the winter season. The freshwater tank will have to be drained and flushed with a non-toxic anti-freeze before winter storage.

REFER TO THE MANUFACTURER'S MANUAL IN YOUR OWNER'S MANUAL PACKET FOR COMPLETE INSTRUCTIONS AND WARRANTY.

Fresh Water System Maintenance

Very little maintenance is required for the fresh water system, other than annual disinfecting and winterizing. Periodically check the entire system to assure that the hose connections, tube fittings, electrical connections and mounting bolts are properly secured, and free of chafing.

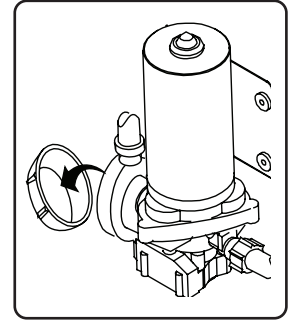

Periodically check the in-line strainer attached to the pump, and clean if necessary.

The system should be run at least every other month to maintain the pump's impellers in a stable operating condition.

Raw Water System

The Raw water system includes a pump, one seacock with auxiliary pump, one livewell and a washdown hose connection.

The seacock must be set in the OPEN position (Figure 3.16.1) for the raw water system to function. The seacock, livewell pump and raw water pump can be accessed through the equipment hatch in the aft cockpit deck.

Make sure that the hull seacock is set in the open position and turn ON the AFT L/W switch on the helm switch panel (see Figure 2.24.1) by pushing

on the top of the switch. The pump will be activated and the system will become functional.

Full-Fill Livewell

Your boat is equipped with a 15 gal. (56.8 L) full-fill livewell located on the aft port side of the transom.

If equipped, the optional 32 gal (121.12 L) livewell in the prep station replaces the cooler, electric grill and refrigerator.

Livewell keep baitfish alive by circulating fresh seawater through the tank.

Livewell
Figure 3.17.1

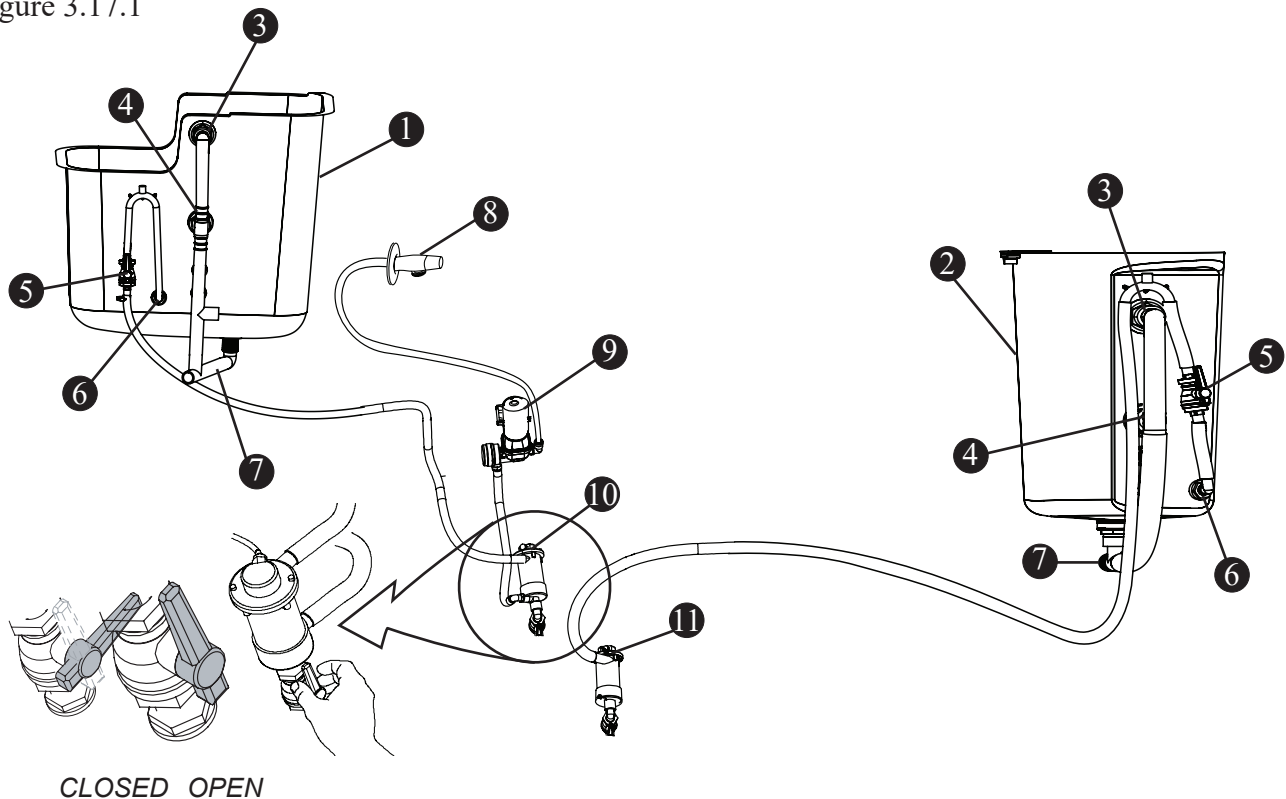

- | | |
|--|--|
| <ul style="list-style-type: none"> ① 15 GAL (56.8 L) AERATED, PRESSURIZED LIVEWELL IN THE PORT TRANSOM ② 32 GAL. (121 L) AERATED, FULL-FILL LIVEWELL IN THE PREP STATION (OPTION) ③ UPPER LEVEL OVERFLOW DRAIN ④ MID LEVEL OVERFLOW DRAIN ⑤ FLOW CONTROL VALVE ⑥ LIVEWELL FILL INLET ⑦ BOTTOM DRAIN | <ul style="list-style-type: none"> ⑧ RAW WATER WASHDOWN FITTING ⑨ RAW WATER PUMP ⑩ AFT LIVEWELL INTAKE/PUMP ⑪ PREP STATION LIVEWELL INTAKE/PUMP (OPTION) |
|--|--|

You can regulate the amount of water in the livewell by inserting the second drain plug (supplied) into the mid overflow drain, thus raising the level of water to the upper overflow drain. This “Full-Fill” design provides a stable environment to reduce fatigue on your baitfish resulting in a more active and longer lasting product.

“Full-Fill” Livewell Operation

- Make sure that the hull seacock is in the open position (see Figure 3.17.1).
- Insert a drain plug (supplied) into the mid overflow drain and fill the livewell completely. The upper overflow drain will allow the water to rise to just below the lid before starting to drain. Maintaining this water level enhances the stability of the water in the tank.
- Open the livewell flow control valve. The flow control valve for the transom livewell is located behind the access door on the aft port side of the cockpit (Figure 3.16.1).

If equipped, the flow control valve for the prep station livewell is accessed through the panel behind the drop down visibility platform.
- Fill the livewell by pressing the switches marked “AFT L/W” & “LP L/W” on the helm switch panel (See page 2-24).

The livewell has three drains to regulate the amount of water in the unit. The bottom drain is used to empty the livewell of water completely. By utilizing the drain plug (supplied) between the two overflow drains in the side of the livewell you can adjust the level of water in the unit. A drain tube with strainer connects to the livewell overflow drains and will direct overflow/excess water to the thru-hull drains.

ATTENTION

The seacock MUST be in the OPEN position when livewell is in use. Running the pump dry may damage the unit.

Livewell

Figure 3.18.1

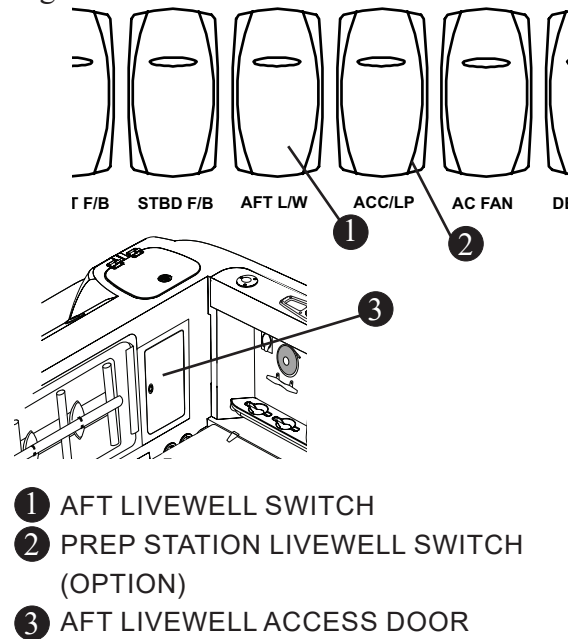

Raw Water Washdown

The raw water washdown hose connection is located on the port gunnel. The fitting allows for connection of a common garden hose. The raw water washdown is supplied by a pump activated by the “RAW WATER” switch on the DC distribution panel located on the port gunnel, midship (Figure 4.7.1).

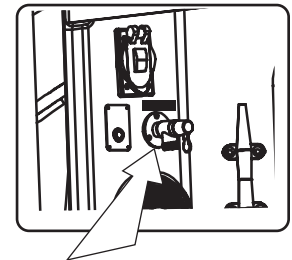

Maintenance

Maintenance of the raw water system requires periodic inspection of the raw water intake strainer and all fittings and hoses for system integrity to prevent leaks.

Clean away debris and/or tighten hose connections as required. The system should be run at least every other month to keep the pumps impellers in good condition.

ATTENTION

The seacock MUST be in the OPEN position when washdown is in use. Running the pump dry may damage the unit.

Head System

Environmental Considerations

The Environmental Protection Agency (EPA) standards state that in freshwater lakes, reservoirs, impoundments whose inlets or outlets are such as to prevent the ingress or egress by vessel traffic subject to this regulation, or in rivers not capable of navigation by interstate traffic subject to this regulation, marine sanitation certified by the United States Coast Guard (U.S.C.G.) installed on vessels shall be designed and operated to prevent the overboard discharge of sewage, treated or untreated or any other waste derived from sewage.

The EPA standards further state that this shall not be construed to prohibit the carriage of Coast Guard certified flow through treatment devices which have been secured so as to prevent such discharges. They also state that the waters where a Coast Guard certified marine sanitation device permitting discharge is allowed include: Coastal waters, Estuaries, The Great Lakes and Intercoastal waterways, Freshwater lakes and Impoundments accessible through locks and other flowing waters that are navigable interstate by vessels subject to this regulation. (40CFR 140.3)

NOTICE

This boat is equipped with a direct overboard discharge valve. Discharging of sewage directly overboard is for use where approved only. Damage to the system could occur if the discharge seacock is not open during operation.

NOTICE

Severe state and federal penalties are levied for discharging raw sewage and solid waste in waters where it is not permitted.

Demonstrating that you have disabled the macerator by locking the system and/or removing the seacock handle may avoid a fine.

It is illegal for any vessel to dump plastic trash anywhere in the ocean or navigable waters of the United States..

Your boat is equipped with a waste disposal system located in the head in the forward cabin.

The waste system includes a VacuFlush toilet, a 7 gal. (26 L) holding tank with vacuum pump and a thru-hull vent.

VacuFlush Toilet

The foot pedal at the base of the toilet opens a mechanical seal which allows a vacuum to force waste through the opening in the bowl to the vacuum generator, through the vacuum pump and then to the holding tank.

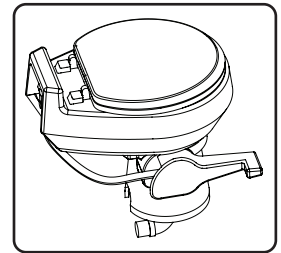

Operation

- The “TOILET” switch located on the discharge panel (see Figure 3.20.1) must be ON.
- If there is no water in the bowl, lift the foot pedal to add sufficient water.
- To flush, depress the foot pedal until bowl is clear.

NOTICE

NEVER use residential tissue paper in your marine waste system.

Waste from the head is directed into the holding tank located in the bilge.

A holding tank fluid level indicator is located on the overboard discharge panel (see Figure 3.20.1) which is located next to the toilet in the head. When the red indicator light is on, the holding tank must be emptied before the head can be reused. However, it would be a good practice to empty the tank sooner to avoid damage to the system.

The vacuum pump is protected by a fuse in the cabin fuse box located behind the port lounge in the cabin (see Figure 2.13.1).

Head System
Figure 3.20.1

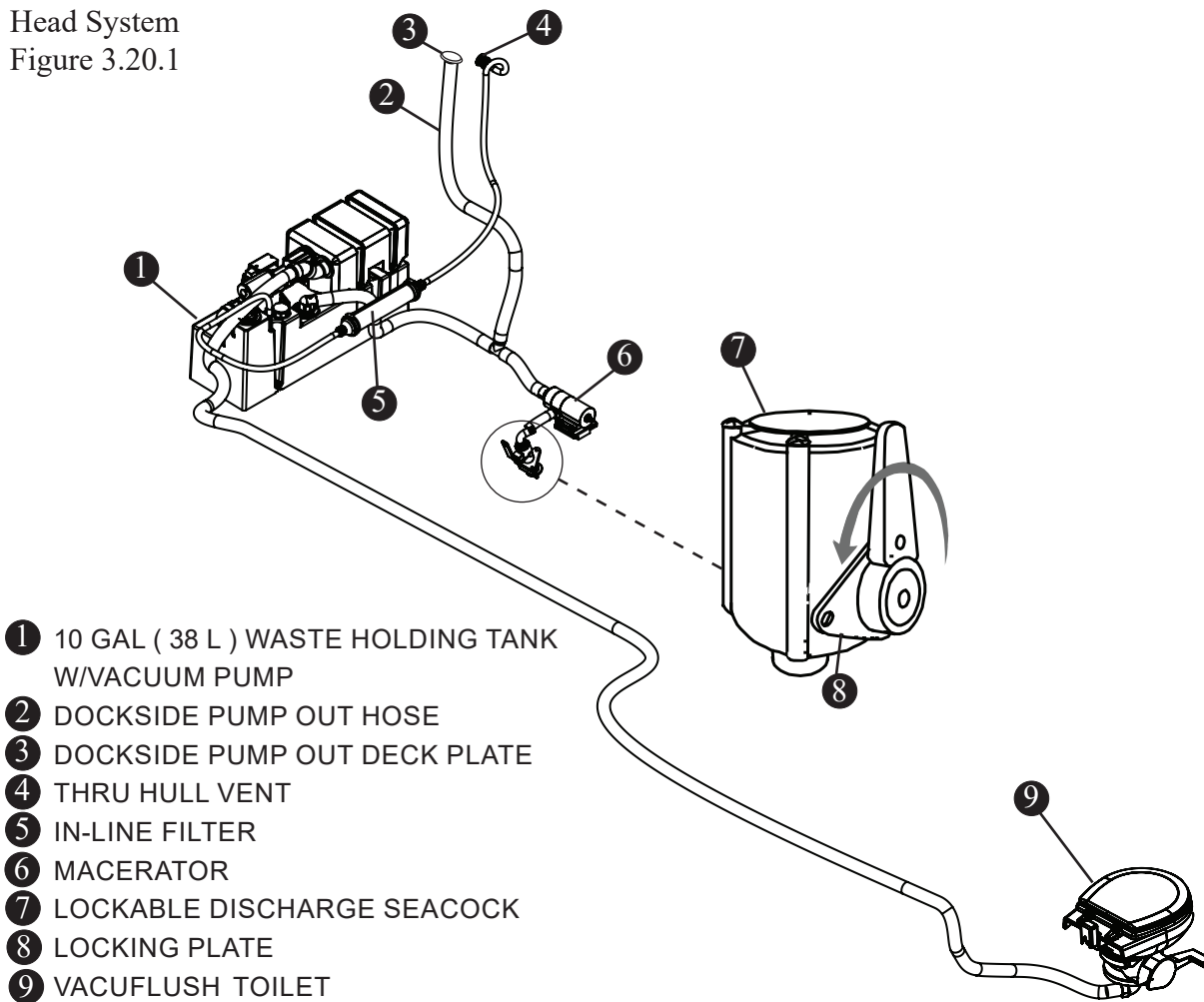

Macerator & Dockside Discharge

The system can be emptied by means of dockside pump out (preferred) through the “Waste” deck plate on the port transom.

The system also provides for overboard discharge by way of a macerator & lockable discharge seacock.

Demonstrating that you have disabled the macerator by locking the system and/or removing the seacock handle may avoid a fine.

To lock the discharge seacock; rotate the handle until the hole in the handle is aligned with the hole in the

locking plate (Figure 3.20.1) and insert a padlock (not supplied).

! WARNING

The discharge seacock should always be in the closed position when the toilet is not in use. Failure to do so could result in flooding or property damage.

NOTICE

Severe state and federal penalties are levied for discharging raw sewage and solid waste in waters where it is not permitted.

Overboard Discharge

The macerator discharge pump draws solid and liquid waste from the holding tank and processes it prior to discharging it overboard through the discharge seacock located in the aft bilge.

There is a control panel located in the head next to the toilet. If the red light located on the discharge panel is on, you **MUST** empty the holding tank before the system will function properly.

- Make sure the discharge seacock is in the open position.
- Insert the macerator key, which is included in your owners manual packet, into the panel.
- De-energize the vacuum pump by depressing the bottom of the “TOILET” switch.
- Depress the foot pedal on the toilet to deplete the vacuum.
- Turn the key clockwise.
- Depress and hold the discharge button until you are satisfied that the tank has been emptied
- Return the key to the upright position.
- Energize the system by depressing the top of the “TOILET” switch.

NOTICE

The “TOILET” switch must remain ON for the system to function properly.

Overboard Discharge Panel

Figure 3.21.1

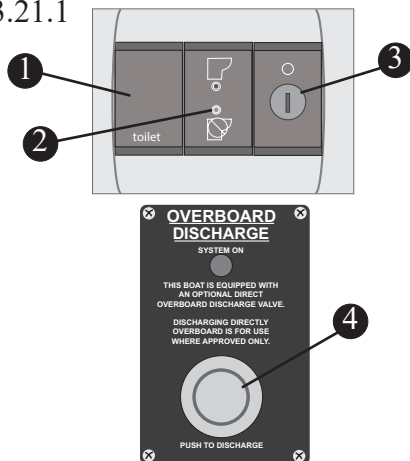

- 1 VACUUM PUMP SWITCH
- 2 RED INDICATOR LIGHT
- 3 VACUUM PUMP KEY SWITCH
- 4 DISCHARGE BUTTON

Maintenance

After long periods of non-use, the macerator pump may not turn freely. Regular use of the system will reduce the chances of this occurring. If the system does require maintenance contact your nearest dealer.

Because your waste system is a low water use device, there is special paper which must be used to prevent clogs.

NOTICE

NEVER use residential tissue paper in your marine waste system.

REFER TO THE MANUFACTURER'S MANUAL IN YOUR OWNER'S MANUAL PACKET FOR COMPLETE INSTRUCTIONS AND WARRANTY.

Dockside Pump-Out

NOTICE

Dockside discharge is the preferred method of waste disposal.

To empty the holding tank, the services of a dockside pump-out station is required. Follow instructions at the station and make sure the pump out hose is inserted into the deck plate marked “WASTE”. located on the port transom.

Access is gained by use of a special key that is included in the owners manual packet.

The dockside facility will have a connection to fit your boat.

NOTE: Prior to using either method of discharging sewage:

- De-energize the vacuum pump by depressing the bottom of the “TOILET” switch.
- Depress the foot pedal on the toilet to deplete the vacuum.
- After completion of the discharge, energize the system by depressing the top of the “TOILET” switch.

Waste System Vent

The waste system vents odors associated with waste operations through the port midship thru hull fitting (Figures 2.7.1).

Replacing Old Vent Filter

NOTICE

Replace vent at beginning of each boating season for most effective odor control.

NOTICE

If holding tank overflow occurs and vent filter becomes fouled, replace vent filter immediately.

The vent filter is located above the holding tank in the bilge (see Figure 3.19.1) and can be accessed through the mechanical hatch in the aft cockpit deck.

- Unscrew vent hose fittings from old vent filter.
- Remove old filter from bracket, seal open ends with tape or wrap inside plastic bag, and discard.
- Install new vent filter in bracket and attach to vent hose fittings.

Avoid overflowing the holding tank. If the red light is lit on the discharge control panel located in the head, you **MUST** empty the holding tank before the system will function properly. However, it is good practice to empty the tank when the 3/4 light is lit. This will avoid an unnecessary inconvenience.

Air Conditioning

Your boat is equipped with two reverse-cycle air conditioning systems. The cabin unit (12000 BTU) controls the temperature in the cabin.

The helm unit (18,000 BTU) controls the temperature in the cockpit.

NOTICE

Helm deck A/C not intended to cool helm deck area with enclosure up.

Operation

The air conditioning/heating systems are controlled by separate touch display panels located on the aft port wall of the cabin.

The display panels allow the operator to preset the temperature for the cabin and/or helm. The air units will activate automatically when the temperature of the cabin/helm is not consistent with the preset temperature. When the air handler is activated, seawater is pumped into the system by way of a seacock and strainer, passes through the compressor cooling the condensing coils, and then flows overboard through the thru-hull drain

Starting the System

- Make sure the seacock is OPEN.
- Turn ON the A/C pump breaker on the “SHORE POWER 1” panel located on the aft port wall of the cabin.
- Turn ON the “CABIN A/C” breaker on the “SHORE POWER 1” panel.
- Turn ON the “DECK A/C” breaker on the “SHORE POWER 2” panel.
- Set the keypad(s) to the desired temperature.

A/C Touch Display Control panel

Figure 3.22.1

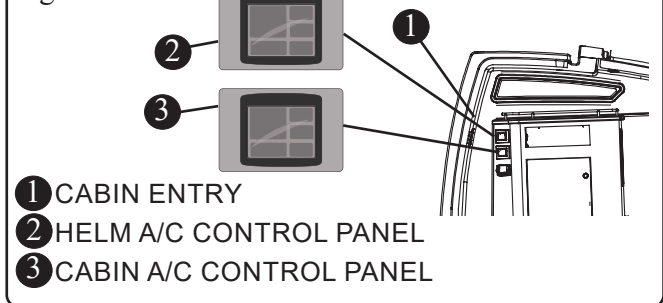

Maintenance

The air conditioning unit requires very simple maintenance. Periodically check and clean the raw water intake on the exterior of the hull, the water strainer at the pump and the air filter.

If need be, The cabin compressor can be accessed through a panel on the lower aft port cabin (see Figure 2.18.1).

Chapter 3 • Systems Overview & Operation

The helm compressor can be accessed through a panel behind the fold-down visibility platform (see Figure 2.21.1)

REFER TO THE MANUFACTURER'S MANUAL IN YOUR OWNER'S MANUAL PACKET FOR COMPLETE INSTRUCTIONS AND WARRANTY.

A/C System
Figure 3.23.1

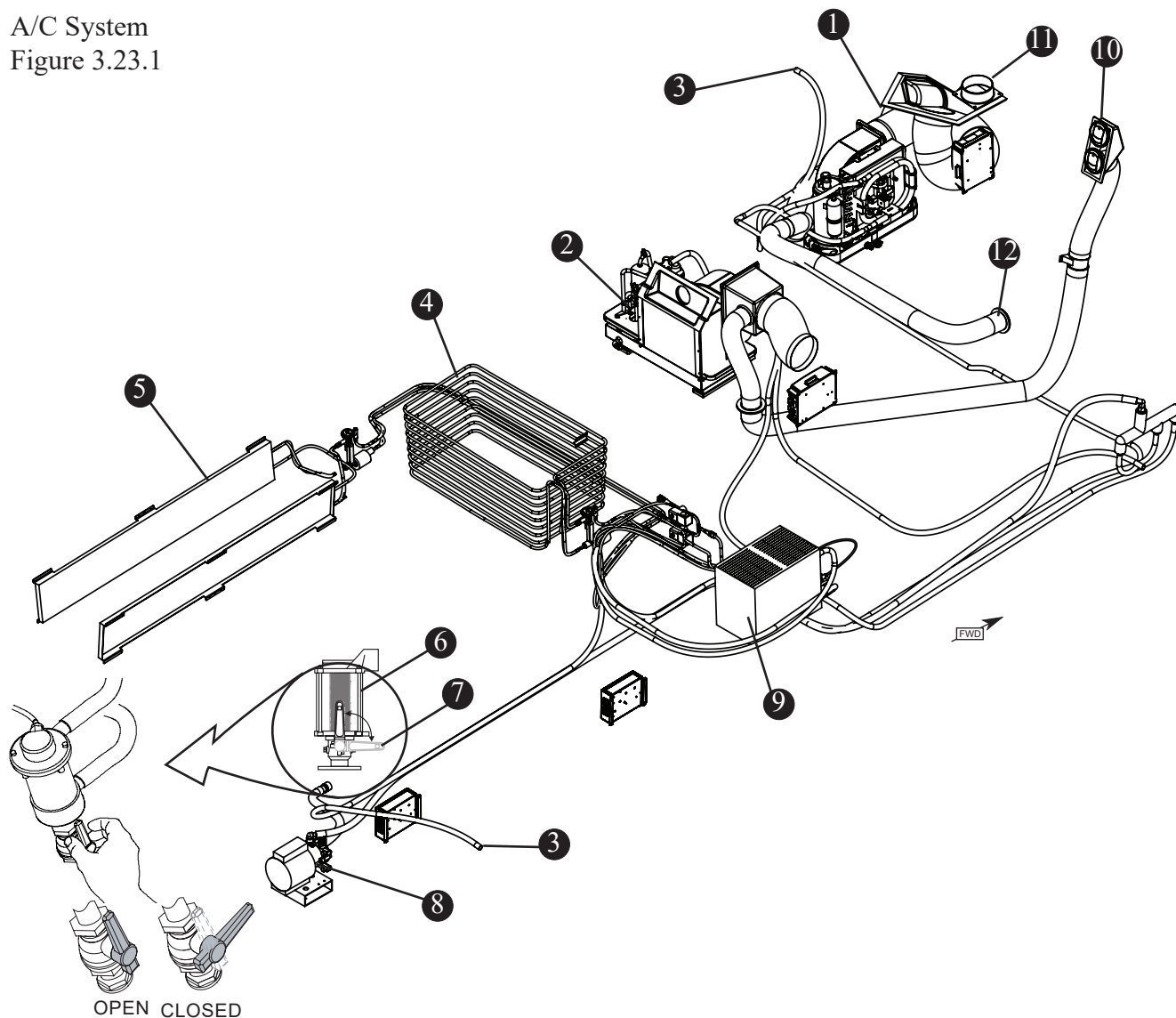

- | | |
|--|-------------------------------------|
| ① CABIN A/C COMPRESSOR (12,000 BTU) | ⑦ RAW WATER INTAKE SEACOCK |
| ② HELM DECK A/C COMPRESSOR (18,000 BTU) | ⑧ A/C PUMP |
| ③ CONDENSATE THRU-HULL DRAIN | ⑨ FREEZER PLATE COMPRESSOR (OPTION) |
| ④ FREEZER COILS (OPTION) | ⑩ CONSOLE AIR VENT |
| ⑤ FREEZER PLATE (PORT FISH BOX) (OPTION) | ⑪ CABIN AIR VENT |
| ⑥ WATER STRAINER | ⑫ HEAD AIR VENT |

Engine Flush System (Option)

Figure 3.24.1

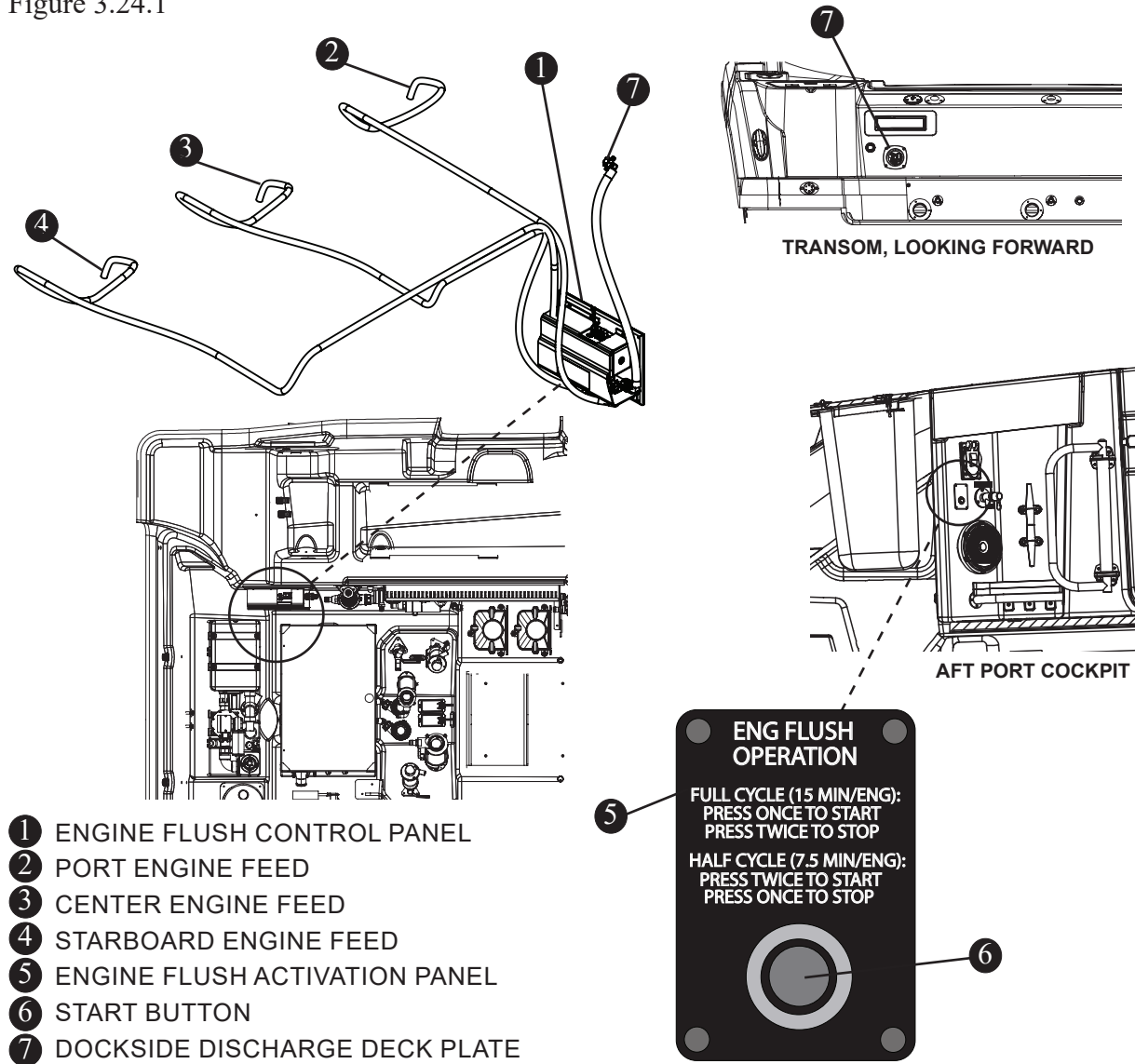

Automatic Engine Flush System (Option)

Full Cycle (15 minutes)

If equipped, the engine flushing system is fully automatic and flushes salt and minerals from the internal components of marine engines more effectively and conveniently than conventional methods.

- Push the start button (Figure 3.24.1) once. The system will cycle for 15 minutes per engine.
- Push the start button twice to stop in the middle of cycle if desired.

Operation

- Attach a water hose to the hose fitting located on the port side of the transom (Figure 3.24.1),
- Activate the system by depressing the button on the panel located on the aft port gunnel (Figure 3.24.1) for a full or half cycle

Half Cycle (7.5 minutes)

- Push the start button (figure 3.24.1) Twice. The system will cycle for 7.5 Minutes per engine.
- Push the start button once to stop in the middle of cycle if desired.

Generator (Option)

It is recommended that you read and understand the information in the manufacturers owners manual before operating the generator.

The gas powered generator is driven by a self contained engine and provides 120 Volt Alternating Current, (AC). Connections to the AC electrical system are made through cables connected to the slide selector switch on the AC distribution panel. The generator has a built in cooling pump which draws cooling water through a seacock located in the aft machinery compartment. This water passes through a strainer before entering the engine cooling manifold.

! WARNING

CARBON MONOXIDE can cause severe NAUSEA, FAINTING or DEATH. The exhaust system must be leakproof and routinely inspected.

FIRE Can cause SEVERE INJURY or DEATH. Do not smoke or permit flames or sparks near fuels or the fuel system.

EXPLOSIVE FUEL VAPORS Can cause SEVERE INJURY or DEATH. Use extreme care when handling, storing and using fuels.

MOVING PARTS Can cause SEVERE INJURY or DEATH. Operate the generator set only when all guards, screens and covers are in place.

Generator, Gas (Option)

Figure 3.25.1

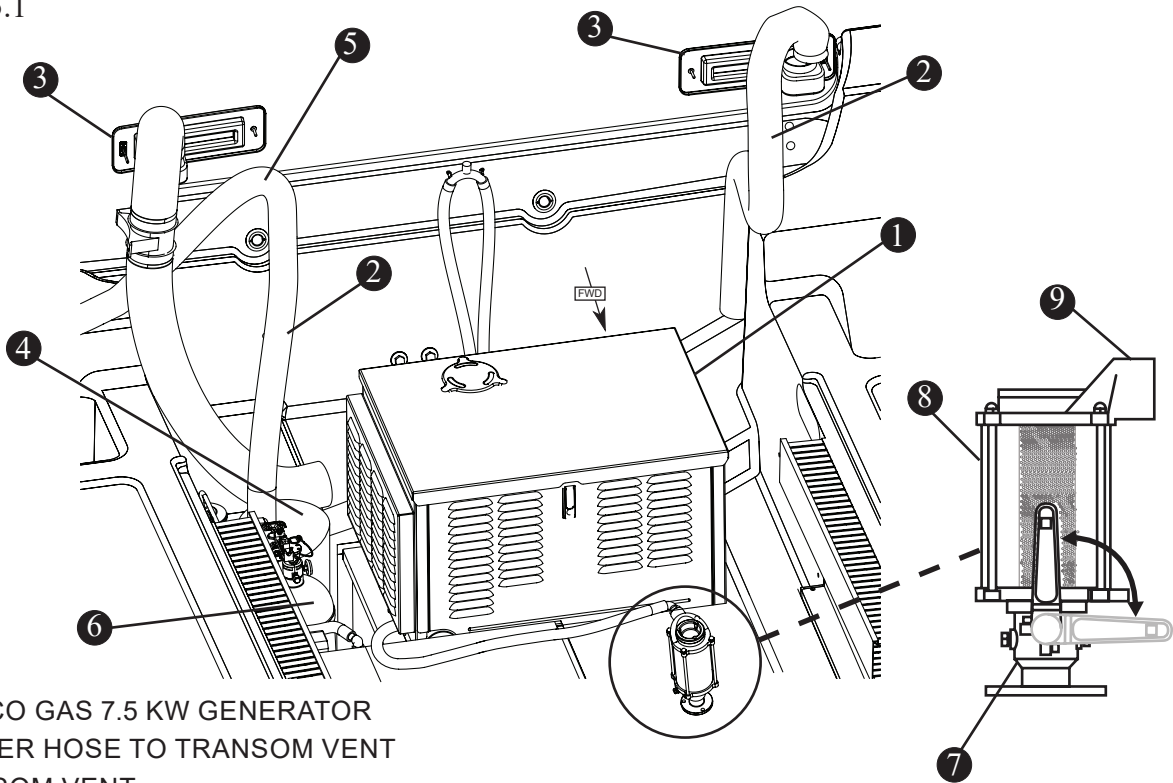

- ① LOW CO GAS 7.5 KW GENERATOR
- ② BLOWER HOSE TO TRANSOM VENT
- ③ TRANSOM VENT
- ④ MUFFLER
- ⑤ EXHAUST TO STARBOARD THRU HULL
- ⑥ FIRE EXTINGUISHER
- ⑦ RAW WATER INTAKE SEACOCK
- ⑧ WATER STRAINER
- ⑨ OUTLET TO GENERATOR

NOTICE

The generator should be shut off before the fuel level reaches the 1/4 tank level where it is designed to run out of fuel.

Chapter 3 • Systems Overview & Operation

The generator draws fuel from the main fuel tank. The generator fuel system is designed to run out of fuel with about 1/4 tank of fuel remaining, leaving a reserve of fuel for the propulsion engines.

Do not run the generator set out of fuel because the fuel lines will draw in air and necessitate bleeding the system before restarting the unit. The generator should be shut off before the fuel level reaches the 1/4 tank level where it is designed to run out of fuel.

The operations manual included in the owners packet will have complete instructions on bleeding the fuel system should it be needed.

The exhaust from the generator passes through a high efficiency marine lift type water cooled muffler and is discharged by a flexible hose via a through hull fitting. The generator has a housing which acts as protection and a sound shield. It can be removed by pulling latches located on the housing.

Start Generator

ATTENTION

Ensure generator seacock is open before starting. Close seacock when generator is not in use to prevent generator damage while underway.

Your owner's manual packet will have the complete operations manual for your generator. Be sure to read the manual before operating the generator. Several key points are indicated below:

- Operate the blower for 4 minutes and manually check the bilge for fuel vapor.
- Refer to the manufacturers operations manual for a pre-start checklist.

- Open the generator seacock.

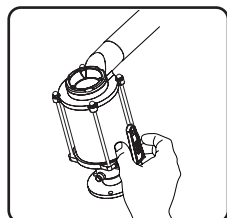

- The generator breaker must be turned off to start.

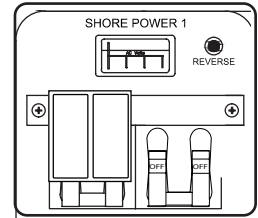

- Check for water in the strainer.

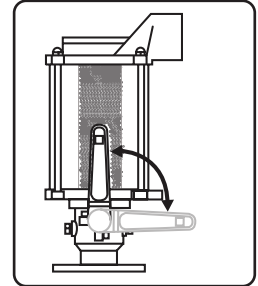

- Press the start/stop button until the generator starts (the green light will illuminate).

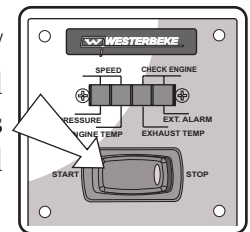

Do not crank the generator for more than 20 seconds at a time. Allow for a 60 second cool down period between cranking attempts.

If the generator fails to start after the first attempt, close the seacock to prevent water from getting into the generator. Open the seacock when the start sequence is successful. If the unit fails to start after 3 attempts, contact an authorized dealer/distributor for service.

Stopping The Generator

- To stop the generator, press the on/off button.

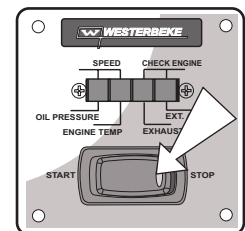

Maintenance

! WARNING

ACCIDENTAL STARTING can cause severe injury or death. Disconnect the battery cables before working on the generator set. Disconnect the negative, (-) cable first when removing and reconnect it last when replacing.

Your operations manual will have a complete maintenance schedule that will need to be followed to keep your generator in peak operating condition. Inspect the parts often and perform required service at the prescribed intervals. Maintenance work must be performed by appropriately skilled and suitably trained maintenance personnel familiar with generator set operation and service.

Operation in European Union Member Countries

This generator set is specifically intended and approved for operation below the deck in the engine compartment. Operation above the deck and/or outdoors would constitute a violation of European Union Directive 2000/14/EC noise emission standard.

REFER TO THE MANUFACTURER'S MANUAL IN YOUR OWNER'S MANUAL PACKET FOR COMPLETE INSTRUCTIONS AND WARRANTY.

Raw Water Strainer Maintenance

Periodically check the raw water strainer for debris and clean as necessary (see Figure 3.27.1).

1. Ensure generator is not running.
2. Remove the cap.
3. Remove the strainer and clean it of debris.
4. Replace the strainer.
5. Replace the cap.

Raw Water Strainer
Figure 3.27.1

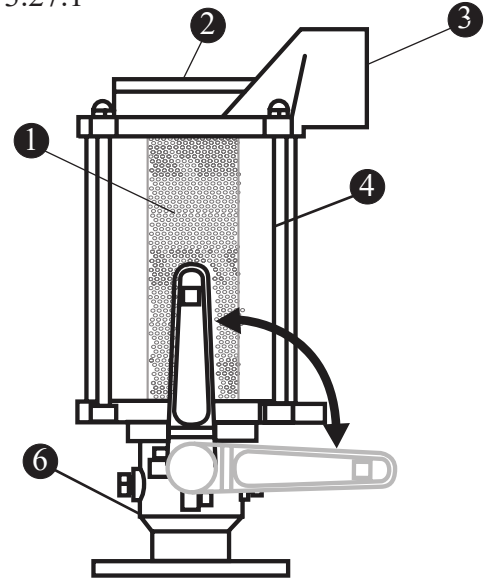

- 1 STRAINER
- 2 REMOVABLE CAP
- 3 OUTLET
- 4 CLEAR BODY
- 5 INTAKE SEACOCK

REFER TO THE MANUFACTURER'S MANUAL IN YOUR OWNER'S MANUAL PACKET FOR COMPLETE INSTRUCTIONS AND WARRANTY.

Shore Power (Option)

The shore power system provides dockside power to operate all of your boat's electrical system and charge your batteries.

Use the supplied 50 ft. power cords to connect your boat to a dockside power source. The on board receptacles are located under the aft starboard gunwale. The AC Main Breaker panel for the shore power system is located on the port aft wall of the cabin.

Shore Power hookups
Figure 3.28.1

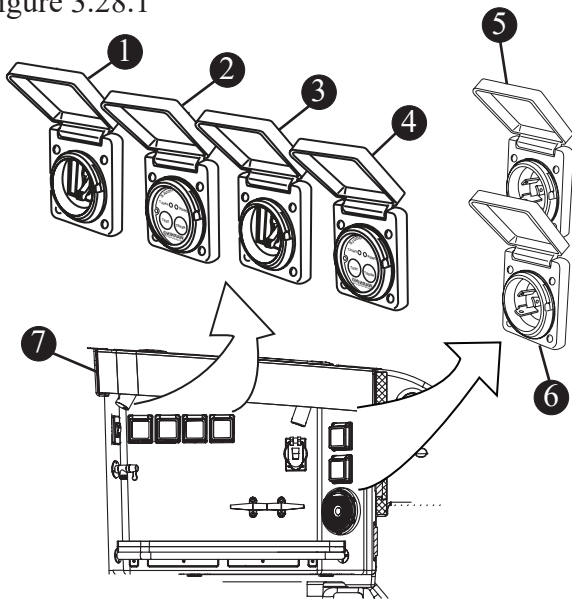

- ① SHORE POWER INTERMEDIATE BREAKER
- ② ELCI (EQUIPMENT LEAKAGE CIRCUIT INTERRUPTER)
- ③ LINE 2 SHORE POWER INTERMEDIATE BREAKER
- ④ LINE 2 ELCI (EQUIPMENT LEAKAGE CIRCUIT INTERRUPTER)
- ⑤ SHORE POWER RECEPTACLE
- ⑥ LINE 2 SHORE POWER RECEPTACLE
- ⑦ AFT STARBOARD COCKPIT

⚠ DANGER

EXTREME HAZARD - Swimming near a boat operating on an AC electrical system can lead to severe shock and/or death. Never swim or allow swimming when AC system is in use.

ELCI (Equipment Leakage Circuit Interrupter)

The shore power system on your boat includes an equipment leakage circuit interrupter (ELCI) located on the aft starboard freeboard (see Figure 3.27.1).

The ELCI is designed to protect people from line-to-ground shock hazards which may occur from defective, misused or neglected electrical equipment. The ELCI will not prevent line-to-ground electric shock, but does limit the time of exposure to a period considered safe for normal healthy persons. If an imbalance of current is sensed, the ELCI will trip when the ground fault exceeds 0.030 amps. This tripping action will occur within a fraction of a second to prevent serious injury.

⚠ DANGER

The receptacle will not protect against line-to-line or line-to-neutral faults, short circuits or overloads.

TESTING & TROUBLESHOOTING TEST BEFORE EACH USE

NORMAL OPERATING STATE - sensing device green led is on and circuit breaker is at on position.

Step 1 - press test button. Green led should go out and red led should come on and circuit breaker should trigger to off position.

Step 2 - if sensing device led or breaker does not trip or change state do not use. Consult an electrician for assistance.

Step 3 - press reset button. The red led should turn off and the green led should turn on.

Step 4 - manually reset (switch) circuit breaker to on position to restore circuit power.

⚠ WARNING

If above tests fail, do not use. Consult a qualified electrician for repair or replacement.

⚠ CAUTION

- Be certain that the shore power main switch is turned OFF before connecting the power cord cordset.
- Connect the cordset to the boat inlet first, then to the shore inlet.
- Never alter the cordset connectors.

Shore Power Operation

Before making shore power connections make sure your boat is properly moored.

- Slide the covers on the shore power 1 & shore power 2 panels to expose the “MAIN” breakers.

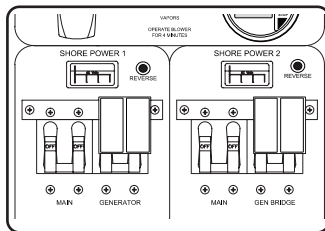

- make sure the breakers are OFF.

- Assure that ALL component breakers are OFF.

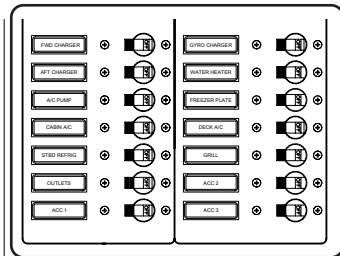

- Using the shore cords, (supplied) connect the female plug to the boat receptacle first.

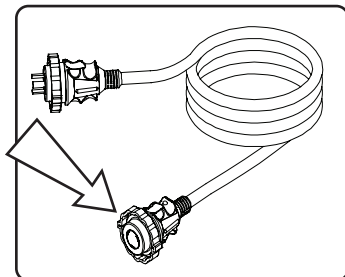

⚠ CAUTION

Shore power cords should be secured or routed to avoid laying or falling into water and to avoid stress on shore power plug and inlet.

- Next connect the male plug to the dockside panel.

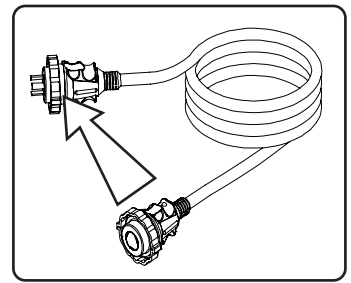

- Turn dockside panel breakers ON.

- Switch the boat side shore power breaker(s) ON.

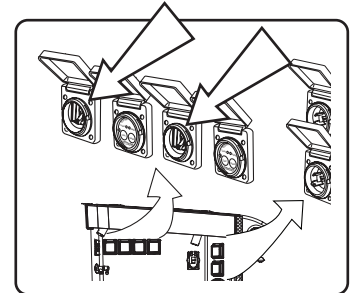

- Switch the shore power main breaker(s) ON.

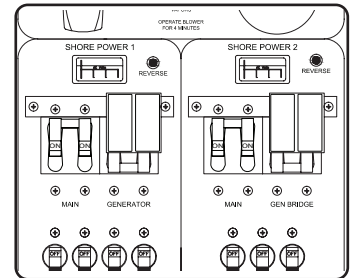

- It is now safe to turn on component breaker.

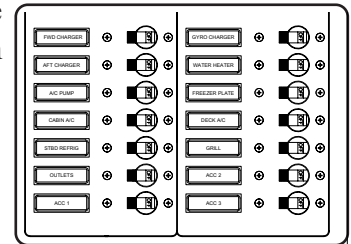

⚠ CAUTION

The use of extension power cords is not recommended. Excessive power cord extensions can cause a voltage drop and may prevent some electronic devices from operating properly.

⚠ CAUTION

It is imperative that the shore power outlet is dry before plugging into the dock power outlet.

Chapter 3 • Systems Overview & Operation

Single Cord Shore Power

In some cases you may be limited to operating your boat's equipment utilizing only a single shore power cord. The following procedure will provide the most efficient power to the boat.

- Slide the covers on the panel to expose the **GENERATOR & shore power 2 MAIN** breaker.

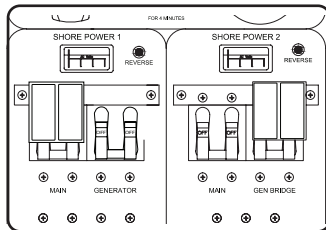

- make sure the breakers are OFF.**

- Assure that **ALL** component breakers are **OFF**.

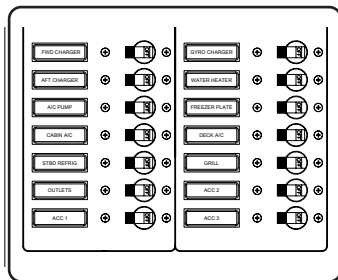

- Using the shore cords, connect the female plug to the boat receptacle first.

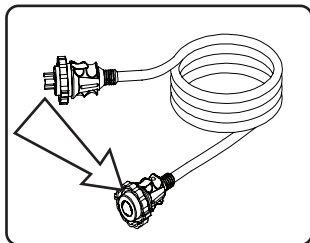

- Next connect the male plug to the dockside panel.

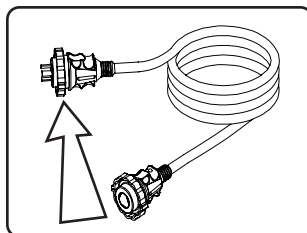

- Turn dockside panel breakers **ON**.

- Switch the boat side shore power breaker(s) **ON**.

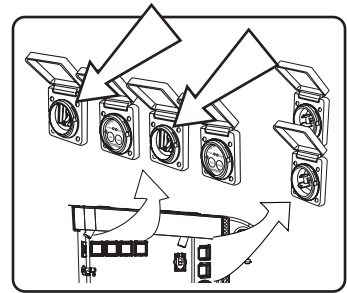

- Switch the **GENERATOR & shore power 2 MAIN** breakers **ON**.

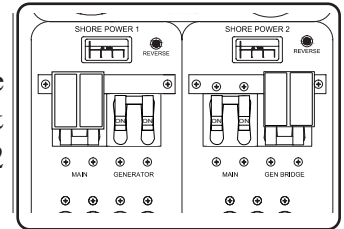

- It is now safe to turn on component breaker.

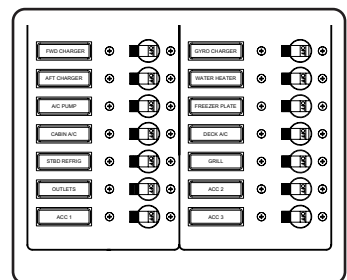

The single cord shore power scenario described in the previous column utilizes the generator to supplement power. Although this setup provides maximum voltage to your boat, you may find at times that the generator noise is too interruptive. You can still power your boat sufficiently by utilizing the breakers as follows:

- Slide the covers on the panel to expose the **SHORE POWER #1 & BRIDGE** breakers.

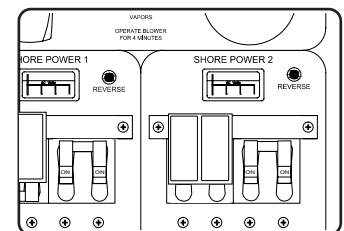

- make sure ALL breakers are OFF.**
- Proceed with setup as described above.

Battery Charging

In addition to supplying AC power to your boat, shore power hookup gives you the ability to charge your batteries without running the engines.

The system is automatic and little or no maintenance is required. The battery charger can be accessed through the equipment hatch in the aft cockpit deck.

Shore Power Load Management

Your boat is equipped with many devices that require AC power for their operation. While many of these devices are continuous use items, others are not.

The design of the electrical system has been optimized to support the most commonly used equipment. However, there may be situations where the operator will need to power off certain appliances based on load requirements, shore power connections and/or generator operation.

To obtain the most power for your appliances, it is best to use the “GENERATOR” and “SHORE POWER 2” combination which will deliver a higher load capability.

Isolation Transformer

Your boat is equipped with isolation transformers which blocks low voltage DC on the shore power ground wire.

The isolation transformers prevent dockside electrolytic voltages from damaging the metal parts of your boat which come in contact with the water. Additionally, the isolation transformers will safely conduct high currents (above 1.5 volts) to ground in the event of a short circuit or power leakage on your boat.

Maintenance

The isolation transformers on your boat are highly reliable. They should, however, be tested once per season, and re-tested after a condition that may have influenced them, such as a lightning strike in the vicinity, or on-board electrical short that either caused a circuit breaker or fuse to blow.

CAUTION

Under normal conditions the zincs on your boat should last at least one year, much longer if no problems occur. If abnormal deterioration of the zincs occur a problem exists and should be corrected immediately.

REFER TO THE MANUFACTURER'S MANUAL IN YOUR OWNER'S MANUAL PACKET FOR COMPLETE INSTRUCTIONS AND WARRANTY.

Fire Suppression System (Option)

NOTICE

The fire extinguishant contained in this unit is dichlorotetrafluoroethane, None of the components in this material is listed by major health associations as a carcinogen. Toxic by-products are produced when this agent extinguishes fire. Avoid breathing these fumes.

If equipped, your boat has a USCG approved automatic fire suppression system that is installed with the generator option. The automatic fire suppression system is located in the starboard side of the machinery access compartment. The system will activate when the temperature in the enclosed area reaches 165°F (74°C).

DANGER

DO NOT handle the actuator. The fire suppression system is under pressure (195 psi.). Accidental discharge may result in death or serious injury.

When activated there will be a bang, (similar to small arms fire) followed by a rushing air sound. Once activated the engine and blower will shut down automatically.

A small panel located at the console will indicate that discharge of the suppression system has occurred (Figure 3.32.1).

Fire Suppression Panel
Figure 3.32.1



⚠ CAUTION

Never attempt to modify or disassemble any components of this system. If the system has been discharged, have a qualified technician replace it.

Manual Override System

The automatic fire extinguisher can be activated manually by pulling the manual override handle located on the starboard front of the prep station.

Early detection and use of the manual override system will reduce fire damage by eliminating the time necessary for heat in the bilge to rise sufficiently to activate the automatic fire system.

In The Event of Discharge:

- Shut down all electrical systems, engines and extinguish all smoking materials.
- Allow the agent to “soak” the compartment for at least 15 minutes.
- DO NOT open the machinery access compartment hatch.
- DO NOT breathe the fumes or vapors caused by fire as they are hazardous and toxic.
- When opening the hatch, have a portable fire extinguisher at hand and ready for use.
- High concentrations of the agent may cause DEATH without warning. The vapor reduces available oxygen for breathing.
- If possible; allow the compartments vapor to dissipate before opening the hatch.

⚠ DANGER

Inhalation of high concentrates of the contents of the fire suppression tank may cause sudden death without warning.

Skin contact will require flushing of the area with water for at least 15 minutes. Seek immediate medical assistance.

To Operate

1. Pull pin securing the handle.
2. Pull red FIRE handle quickly and briskly.

Fire Suppression Panel
Figure 3.32.2

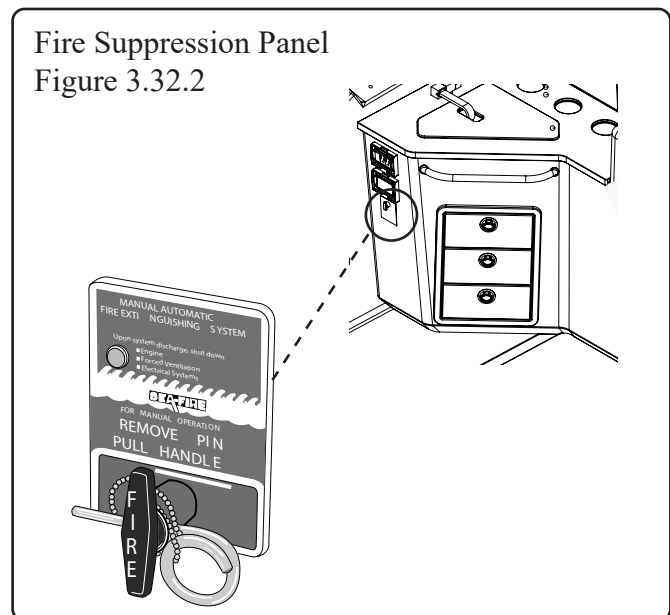

REFER TO THE MANUFACTURER'S MANUAL IN YOUR OWNER'S MANUAL PACKET FOR COMPLETE INSTRUCTIONS AND WARRANTY.

Dive Door

The innovative design of your boat includes a port side door for ease of transition to and from the water or dock. The door opens wide and features a swivel grab handle to assist persons entering or exiting the water. To use the grab handle, lift up and swivel into place.

The stainless steel deck bracket accommodates a removable ladder which is stowed in the base of the aft bench seat when not in use.

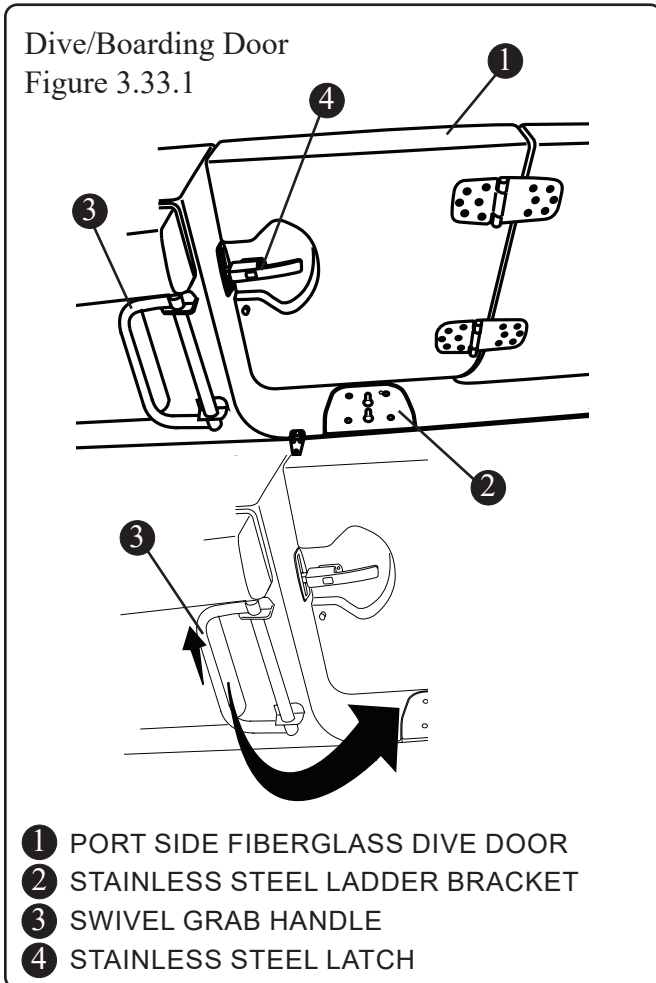

⚠ DANGER

Ensure that door is closed and securely latched when boat is underway.

Dive Ladder

⚠ DANGER

The dive ladder should NEVER be deployed when boat is in motion or the engines are running.

To avoid risk of injury or death, shut off engines when using the dive door to enter or exit the water.

The installation of the dive ladder is quick and easy.

- Remove the ladder from its stowed position on the base of the aft bench seat.
- Rotate the brace at the top of the ladder so that it is perpendicular to the shaft.
- Insert the two pegs on the brace into the deck bracket.
- Secure the ladder into place by pushing the brace outboard until it seats firmly into the bracket and the locking pin has snapped into place.

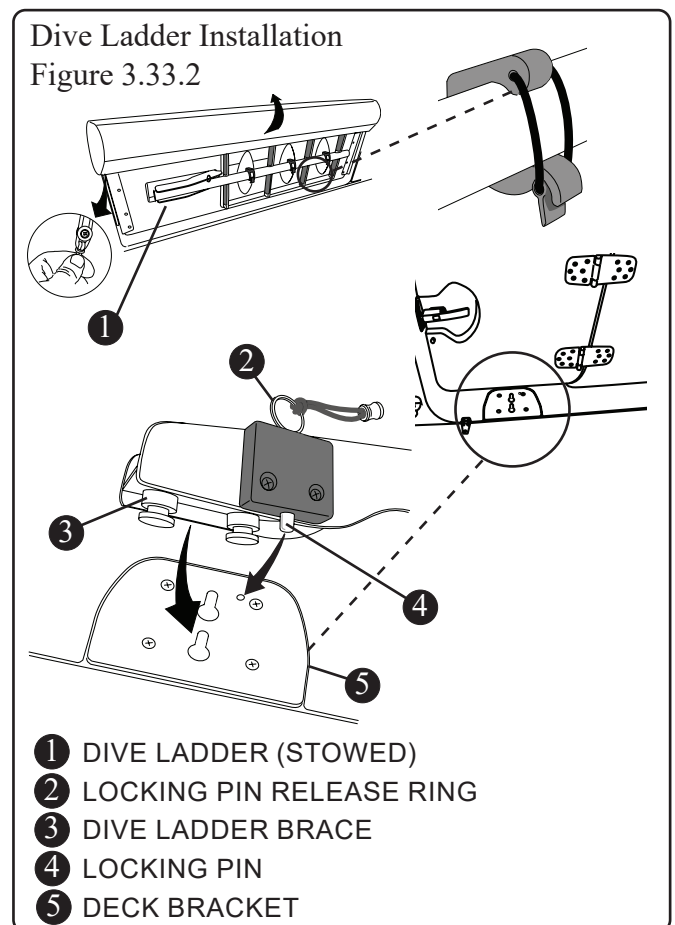

To remove the dive ladder from the dive door bracket:

- Pull up and hold the release ring.
- Pull dive ladder brace inboard and lift up out of the deck bracket.

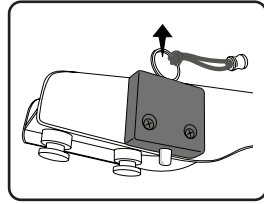

- Secure the ladder into place on the aft bench seat (see Figure 3.31.2).

NOTICE

ALWAYS use bungee straps to secure the dive ladder in the aft bench seat brackets (see Figure 3.35.2).

Fish Boxes with Pump Out Discharge

Your boat has two deep well, insulated fish boxes (Figure 3.34.1). One each located port and starboard in the cockpit. The boxes have gasketed lids and draw latches for a secure seal. The fish boxes utilize an electrical pump system (see Figure 2.12.1) to discharge water overboard by way of thru-hull fittings port and starboard (See page 2-7).

The cockpit discharge pumps are located in the bilge (P&S) and can be accessed through the mechanical hatch in the aft cockpit deck.

The pumps are independently activated by switches on the helm switch panel (see Figure 2.24.1) and are protected by breakers located on the 12V DC breaker panel behind the door on the port gunnel, midship (see Figure 4.8.1). Check these breakers first and reset if a problem arises with the pumps failing to activate when the switches are depressed.

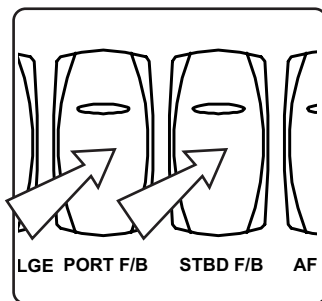

Fish Boxes
Figure 3.34.1

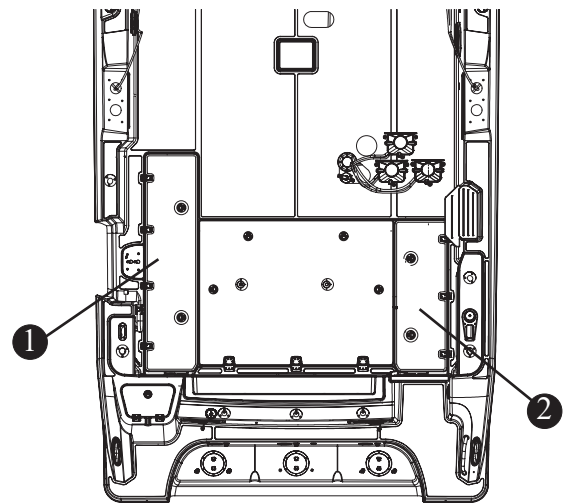

- ① PORT FISH BOX
- ② STARBOARD FISH BOX

Port Fish Box Freezer Plates (Option)

The optional freezer plates (Figure 3.35.1) are available as a single unit for the aft port cockpit fish box.

If equipped, the optional fish box freezer plates transform the port fish box into a deep cold cooler.

The system utilizes the A/C intake seacock to provide the raw water necessary for the plate(s) to function. The water is discharged through a thru hull fitting (see Figure 2.7.1).

The temperature of the fish box can be regulated from the temperature control panel located on the port aft wall of the cabin above the AC breaker panel.

Prep Station Freezer Coils (Option)

If equipped, the optional freezer coils (Figure 3.35.1) transform the prep station cooler into a refrigerator.

The system utilizes the A/C intake seacock to provide the raw water necessary for the plate(s) to function. The water is discharged through a thru hull fitting (see Figure 2.7.1).

Freezer Plates/Coils
Figure 3.35.1

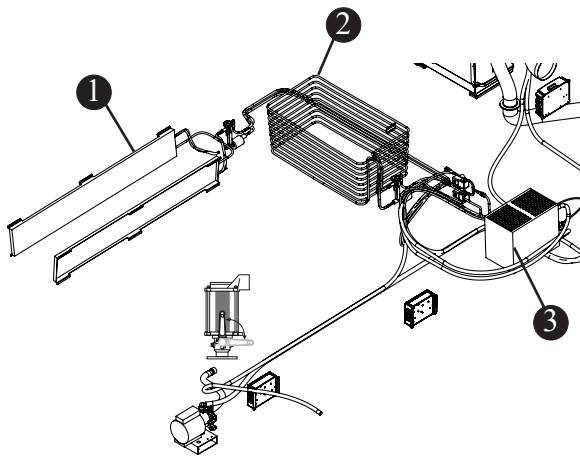

- ① PORT FISH BOX FREEZER PLATES
- ② PREP STATION COOLER COILS
- ③ FREEZER PLATES/COILS COMPRESSOR

The temperature of the freezer plate and cooler can be regulated from the temperature control panel located on the port aft wall of the cabin above the AC breaker panel.

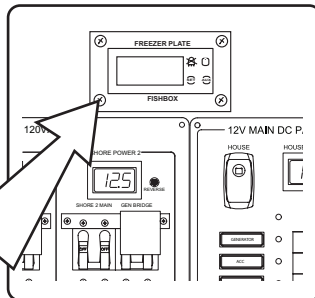

Electric Downrigger Receptacles, (Option)

If equipped, the two 12V/30 amp electrical receptacles for powering electric downriggers, or any electrical equipment aptly rated, are located inside the cockpit on the aft section of the port and starboard gunwales. The plugs are supplied in the owners packet when this option is purchased.

Push the plug into the receptacle and turn clockwise to secure the connection.

The receptacles are protected by 30 amp in-line fuses. The “PORT 30A” and “STBD 30A” breakers on the DC distribution panel (see Figure 4.7.1) must be ON to power the receptacles.

The receptacles are protected by a weatherproof cover. There are areas on the gunwales that are

⚠ CAUTION

The location for mounting of the downrigger base is important, refer to the wood location diagram (See page 5-15) for areas on the gunwales that are specifically designed for withstanding the stress generated by a downrigger.

There are a variety of downrigger mounting base plates that can be used, it is important that you consult with your salesperson to find the mounting base that will best suit your application.

designed specifically for downrigger mounting bases. See the Wood Location Diagram (Section 5, page 5-16) for proper mounting.

There are downrigger weight cradles located in the port and starboard cockpit to store your downrigger weights when not in use.

Consult with your Boston Whaler® dealer for details on selecting and mounting the downriggers that will best suit your application.

12V/30 Amp Receptacles
Figure 3.35.2

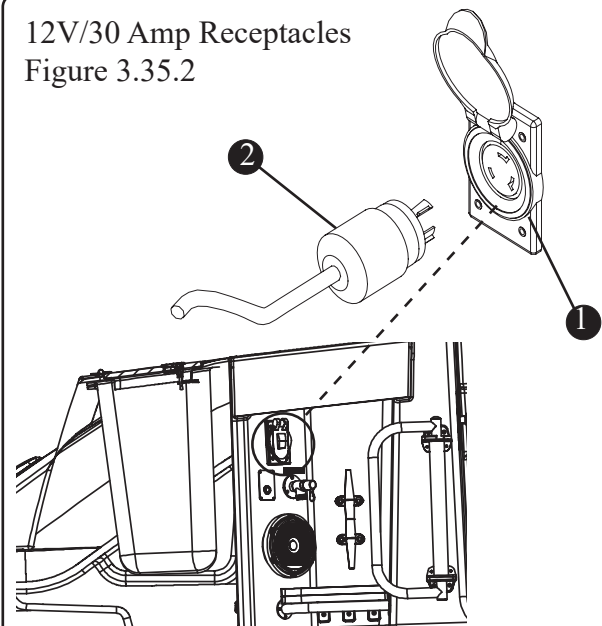

- ① 12V/30A RECEPTACLE (P&S)
- ② PLUG (SUPPLIED)

NOTE: Port side shown, Starboard side typical

REFER TO THE DOWNRIGGER MANUFACTURER'S MANUAL FOR COMPLETE INSTRUCTIONS AND WARRANTY.

Foldaway Aft Bench Seat

When the aft bench is not in use it can be folded flush into the transom. To use the seat; raise the bolster, then, using the handle lift the seat up and out toward you and push down.

Aft Bench Seat
Figure 3.36.1

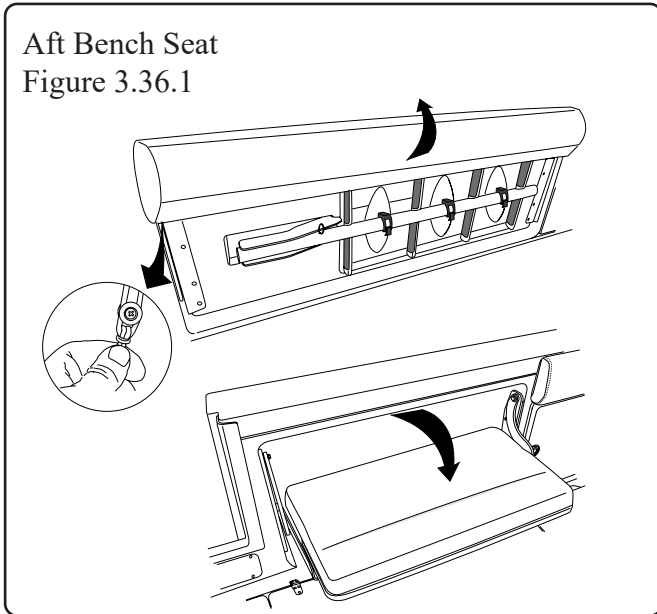

Stowable Cockpit Tables (Option)

Your boat can be equipped with two tables for entertaining in the cockpit. The tables are removable and stowable. If equipped, the table tops are stowed in the underside of the cockpit mechanical hatch along with the pedestals.

Cockpit Tables (Option)
Figure 3.36.2

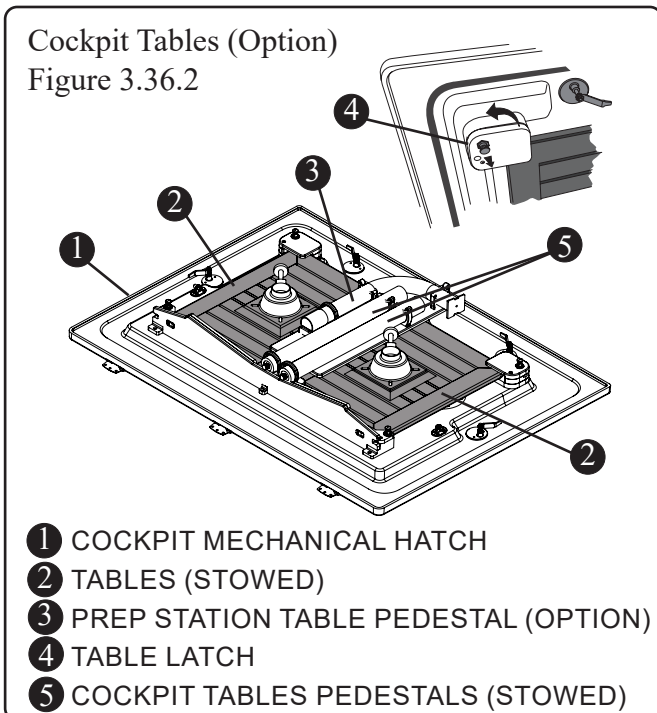

Cockpit Tables (Option)
Figure 3.36.3

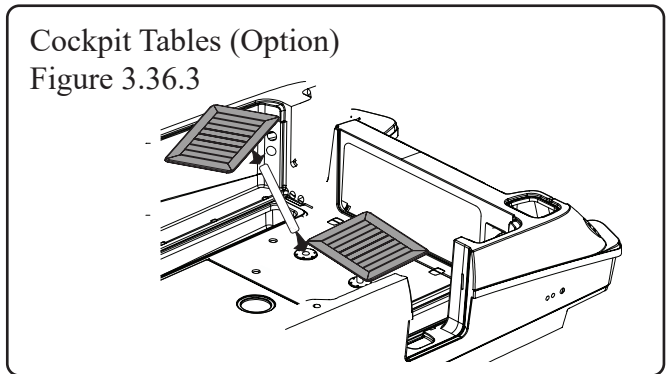

To set up the tables:

- Remove the table top from the underside of the mechanical access hatch by pulling the knob on each of the corner latches and rotating it away from the stowed table.
- Set tables aside in the cockpit.
- Remove the pedestals from the storage clips and place them upright in the receiver plates located on the top of the mechanical hatch in the cockpit.
- Place the tables on the top of the pedestals and assure that they are securely seated on the pedestals.

Prep Station Table (Option)

Using one of the tables and pedestal stowed in the aft cockpit access hatch you can set up for entertaining in the forward cockpit area.

Prep Station Table (Option)
Figure 3.36.4

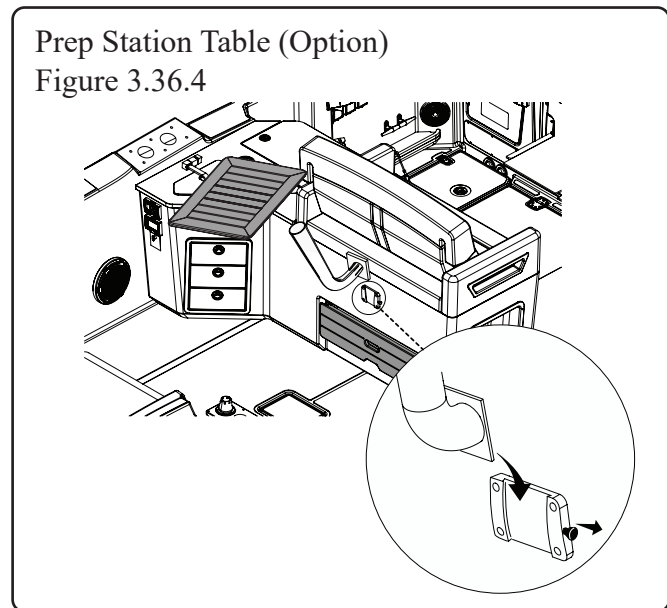

Electric Grill (Option)

⚠️ WARNING

Please read and understand the safety precautions found in the Kenyon® Custom Electric Grill owner's manual located in your owner's packet.

If equipped, the electric grill located under a removable cover on the starboard side of the prep station (Figure 3.37.1) provides a safe method of grilling without the hazard of open flames associated with propane gas or charcoal grills.

The grill is powered by shore power, if connected or generator. The "GRILL" breaker on the AC Main Distribution Panel (See page 4-10) must be ON to operate the grill.

To Access The Grill:

- Lift up on the cover latch (Figure 3.37.1). The cover will rise up.
- Rotate the cover counterclockwise until the grill is fully exposed.

To Close The Cover:

- Rotate the cover clockwise until the grill is fully covered.
- Push down on the cover at the point of the latch until cover is seated then close the latch.

Automatic Shut-Off

There is an automatic shut-off switch located at the back of the grill. When the prep station cover is closed the shut-off switch is engaged and power to the grill will be turned off. Do not under any circumstances override the automatic shut-off switch.

⚠️ CAUTION

The electric grill will become dangerously hot.

Depending on the level of heat used for cooking, the grill will automatically shut off 60-90 minutes after ignition. However, it is good practice to close the lid when not in use. This action will engage the automatic shut-off switch and cut power to the grill.

Electric Grill (Option)

Figure 3.37.1

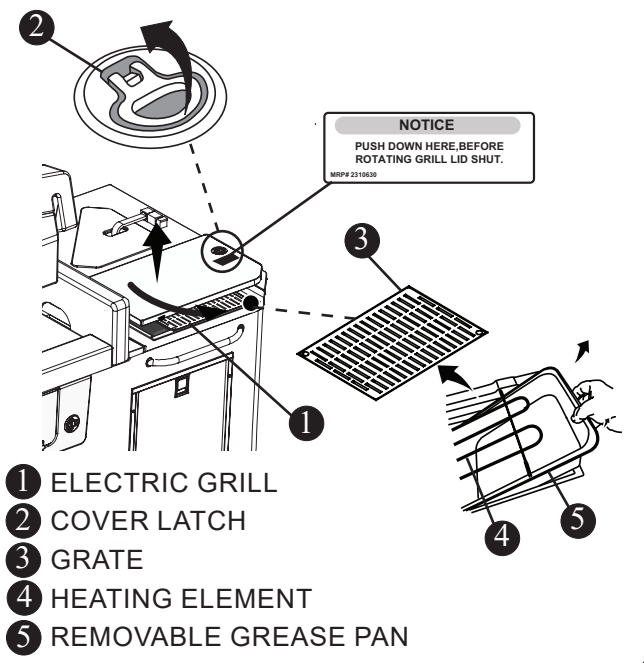

Removable Grease Pan

A concealed electric element eliminates grease flare-ups and a reusable grease pan located under the heating element collects all the fat and juices associated with grilling. **The grease pan must be emptied after each use.**

To remove the grease pan (Figure 3.37.1):

- Remove the grate.
- Lift the heating element.
- Remove the grease pan.

When replacing the pan, assure that it is completely contained within the grill and that the side of the pan does not extend outside of the grill sides.

NOTICE

To prevent the contents of the grease pan from smoking, place 1 cup of water in the grease pan before cooking.

REFER TO THE MANUFACTURER'S MANUAL IN YOUR OWNER'S PACKET FOR COMPLETE INSTRUCTIONS AND WARRANTY.

Radial Outriggers (Option)

If equipped, there are two radial outriggers. One each located on the port and starboard side of the hardtop. The outriggers are adjustable to provide ease of operation and convenient ready-to-use storage.

Operation

Extending Outriggers:

Starting with the outboard section, extend each section out until the locking button snaps into place.

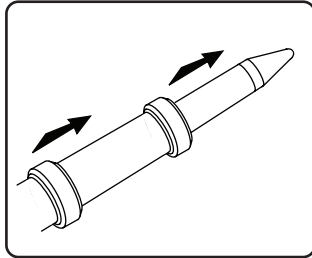

To position the outriggers:

Radial Outriggers (Option)
Figure 3.38.1

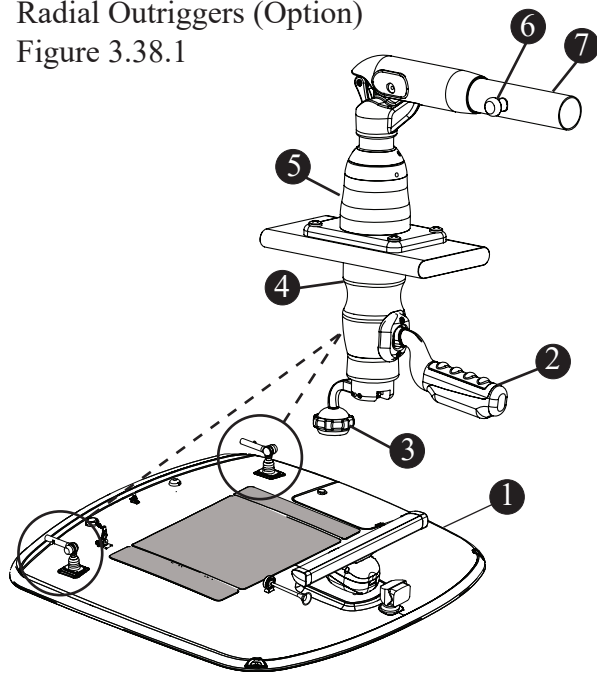

- ① HARDTOP
- ② ROTATION ADJUSTMENT HANDLES
- ③ POWER CRANK HANDLE
- ④ LOWER UNIT
- ⑤ UPPER UNIT
- ⑥ SHAFT LOCK
- ⑦ EXTENDABLE SHAFT

Raising or lowering:

Extend the power crank handle out and lock into place. To raise, turn handle clockwise. To lower, turn handle counterclockwise.

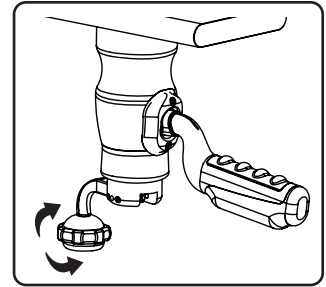

Rotating Outriggers:

Pull down on the lower unit handle and rotate to the desired position. When released the handle will hold the outrigger shaft into position.

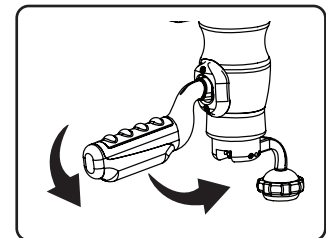

Retrieving Outriggers:

Starting with the inboard most section, Push in the locking button on each succeeding section and insert sections into the shaft until all sections are completely seated in the stowed position.

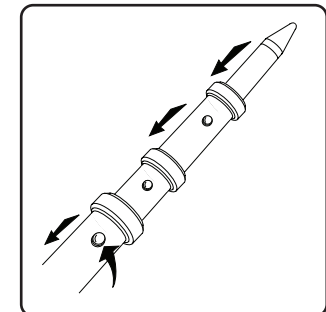

Maintenance

When at port, extend the outriggers and clean with a mild, non-abrasive soap and fresh water, wipe with a dry cloth and allow to air dry. When dry, collapse the outriggers to the stowed position. Periodically lightly lubricate the cam and the shaft of the cam knob.

Radial Outriggers (Option)

Radial Outriggers (Option)
Figure 3.39.1

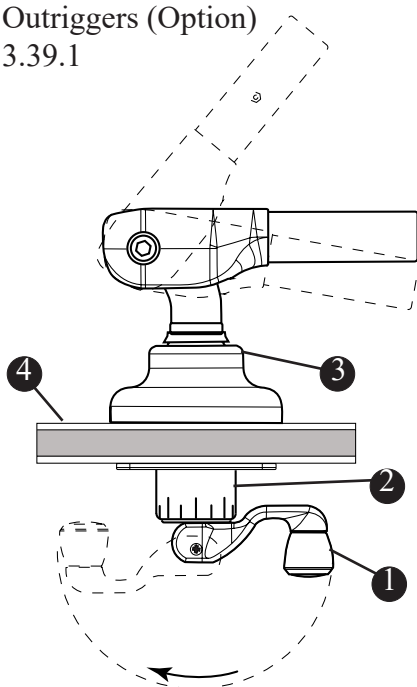

- ① ROTATION ADJUSTMENT HANDLE
- ② LOWER UNIT
- ③ UPPER UNIT
- ④ HARDTOP

If equipped, there are two radial outriggers. One each located on the port and starboard side of the hardtop. The outriggers are adjustable to provide ease of operation and convenient ready-to-use storage. The outriggers use the same handle for raising, lowering, and swinging the outriggers.

Raise/Lower Outriggers

With the handle in the down position, grip knob and rotate the handle clockwise to raise or lower the outboard to the desired position.

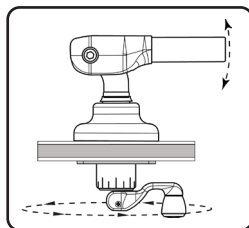

Swing Outriggers In/Out

Once the desired height is reached, flip the handle to the “up” position. Grab firmly on the handle, and rotate the handle to position the outboard to the desired fishing position.

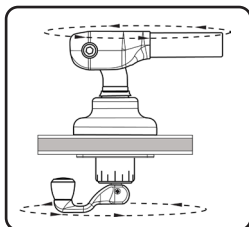

Leaving the base in the down position will keep the base from rotating while fishing and running.

Extend Outriggers:

Starting with the outboard section, extend each section out until the locking button snaps into place.

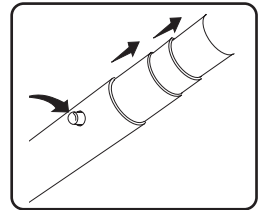

Retrieve Outriggers:

Starting with the inboard most section, Push in the locking button on each succeeding section and insert sections into the shaft until all sections are completely seated in the stowed position.

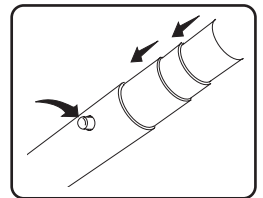

Maintenance

With very little care your equipment will maintain its appearance and operate trouble free. When at port, extend the outriggers and flush with fresh water, wipe with a dry cloth and allow to air dry. When dry collapse the outriggers to the stowed position.

CAUTION

Always ensure clearance of bridges, lights, power lines, etc. while operating your vessel.

ATTENTION

The outriggers have an operable angle (up and down) of 65 degrees to 10 degrees. Please keep this in mind when making adjustments to your outriggers.

REFER TO THE MANUFACTURER'S MANUAL IN YOUR OWNER'S MANUAL PACKET FOR COMPLETE INSTRUCTIONS AND WARRANTY.

Fold Down visibility Platform

The innovative design of the helm incorporates a foldaway platform which can be lowered to provide improved visibility for shorter operators or when conditions mandate.

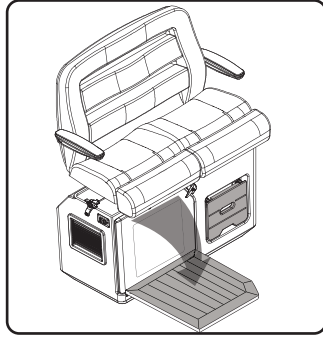

Spotlight (Option)

If equipped, the optional spotlight is mounted forward on the hardtop.

The spotlight with Directional Flexibility is controlled by a wireless remote located at the helm station which gives the operator a full 360° horizontal rotation and vertical tilt with fingertip control.

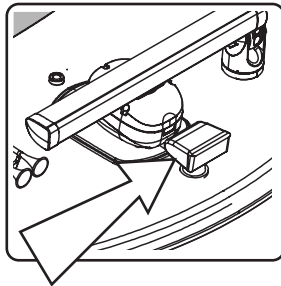

Spotlight Control
Figure 3.40.1

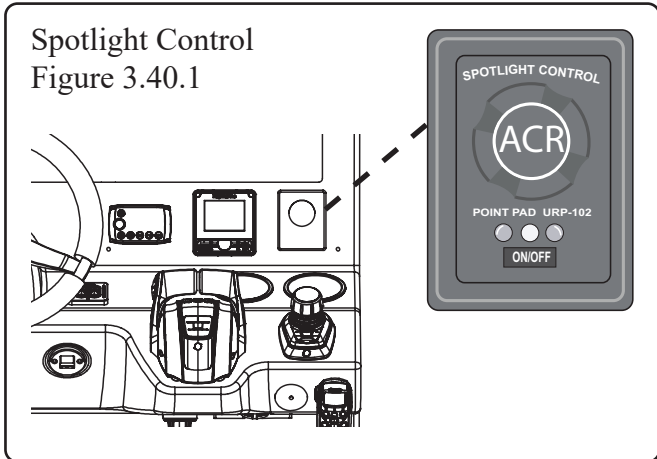

REFER TO THE MANUFACTURER'S MANUAL IN YOUR OWNER'S MANUAL PACKET FOR COMPLETE INSTRUCTIONS.

Bow Table (Option)

ATTENTION

Cover table with the included cover when not in use. Refer to Teak care instructions in Chapter 5.

The optional bow table is electrically actuated, powered by the house batteries. The switch to raise

Bow Table (Option)
Figure 3.40.2

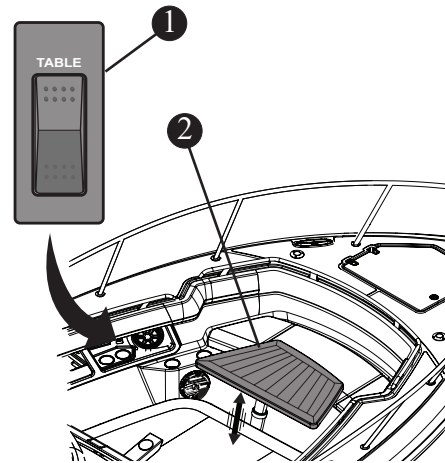

- ① BOW TABLE SWITCH (UP/DOWN)
- ② BOW TABLE

and lower the table is located on the port bow gunnel (Figure 3.40.2).

Fully raised, the table can be used for entertaining in the bow. When completely lowered the table becomes a stable surface for the optional cushion which expands the lounge surface of the bow.

Thermal Night Vision (Option)

Thermal Night Vision (Option)
Figure 3.40.3

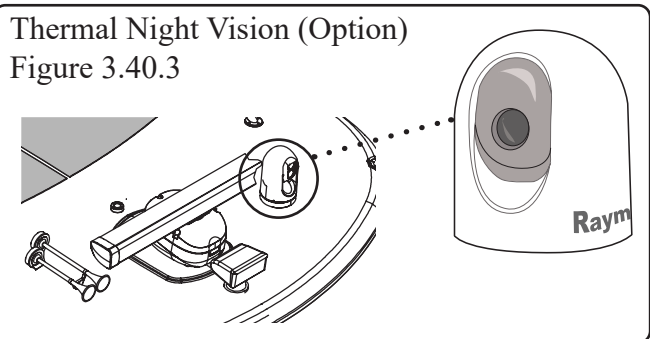

If equipped, the fixed mount thermal night vision camera (Figure 3.39.3) gives the operator the ability to detect floating objects, navigation aids, other vessels and even people in the water at night using thermal imaging technology.

The camera is controlled remotely from the camera application on the Raymarine display.

REFER TO THE MANUFACTURER'S MANUAL IN YOUR OWNER'S MANUAL PACKET FOR COMPLETE INSTRUCTIONS AND WARRANTY.

Cabin Convertible Couch

The port and starboard couch sections in the cabin can be easily and conveniently converted to a full size berth using the uniquely designed accentuator located under the center of the port coach.

To Convert Couch:

- Pull the accentuator (Figure 3.41.1) toward the center of the cabin.

The port couch will glide out to expose a blank space behind the cushion and the platform will extend to accommodate the starboard cushion.

- Pull the starboard seat to the center to meet the port seat.
- Place the port and starboard side cushions (Figure 3.41.1) into the blank areas created by moving the seat cushions toward the center.

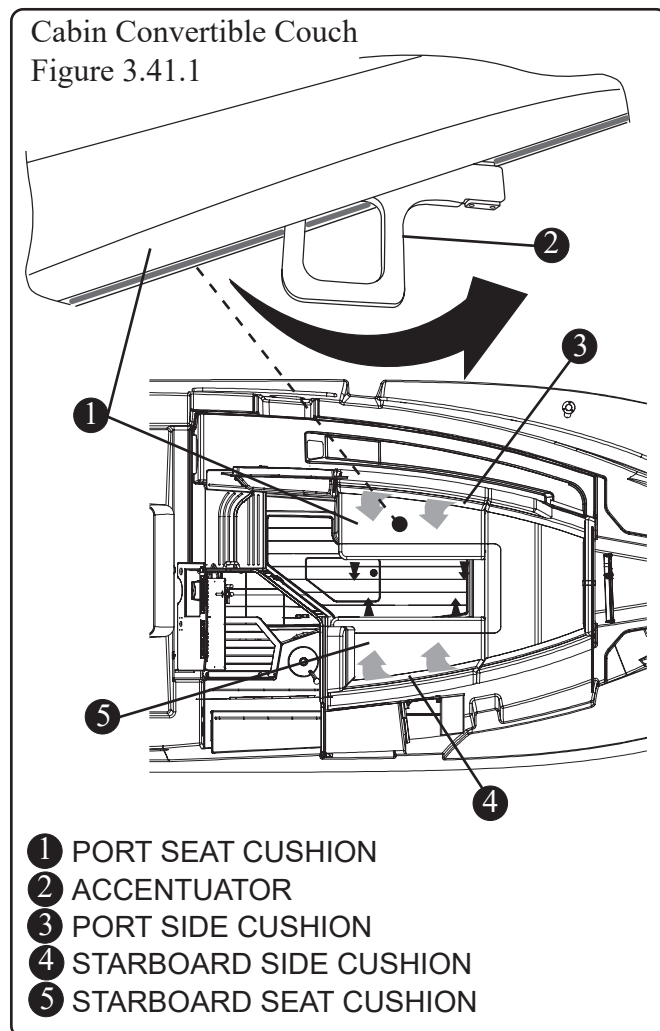

Electric Windshield Vent

The windshield vent at the top of the windshield is electrically actuated. A switch labeled “VENT” is located on the helm switch panel (see Figure 2.24.1).

By depressing the top of the switch you can open the vent. To close the vent depress the bottom of the switch. The vent switch is a momentary switch which means that it must be depressed and held in position for the vent to open or close completely.

Windshield Wiper/Washer

The windshield wiper/washer is controlled by a toggle switch labeled “WIPER/WASH” on the helm switch panel (see Figure 2.24.1). The switch is protected by a reset breaker located on the DC Distribution Panel located on the port gunnel, midship (see Figure 4.8.1).

The windshield washer is activated depressing the bottom of the switch labeled “WASHER/WASH” located on the helm switch panel (see Figure 2.24.1)

NOTICE

Recommended Blade replacement:

ANCO wiper blades - 28 inches

Electric Sun Shade (Option)

If equipped, the electrically actuated cockpit sun shade (SEE FIG. 3.41.1) can be deployed or retracted by depressing the “SHADE” switch located on the helm switch panel (see Figure 2.24.1).

The sun shade is protected by the “SHADE CONTROL” breaker on the DC distribution panel located on the port gunnel, midship (see Figure 4.8.1).

Follow the canvas care instructions in section 5 of this manual to keep the sun shade fabric clean.

NOTICE

A reset functionality has been incorporated into the sun shade controller to enable a service technician to quickly reset the shade position. In the event the shade does not operate at either the fully extended or fully retracted position, contact a Boston Whaler dealer for details.

Electric Sun Shade
Figure 3.42.1

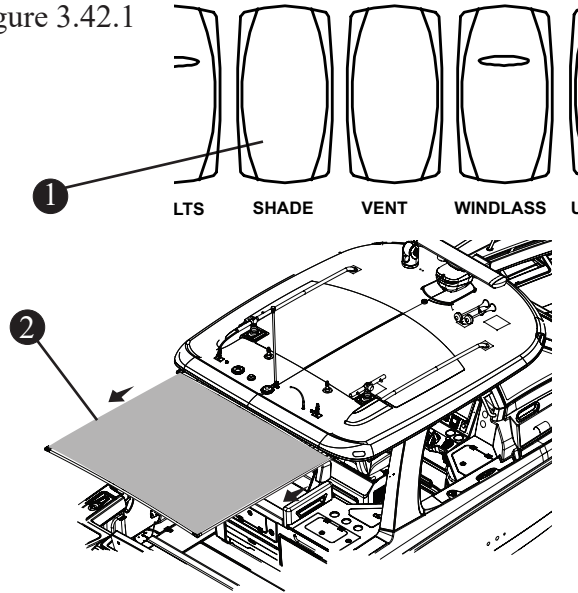

- ① SUN SHADE SWITCH
- ② ELECTRIC SUN SHADE

CAUTION

While underway, the sun shade should be stowed to prevent damage to the rails and or curtain.

Swim Ladder
Figure 3.42.2

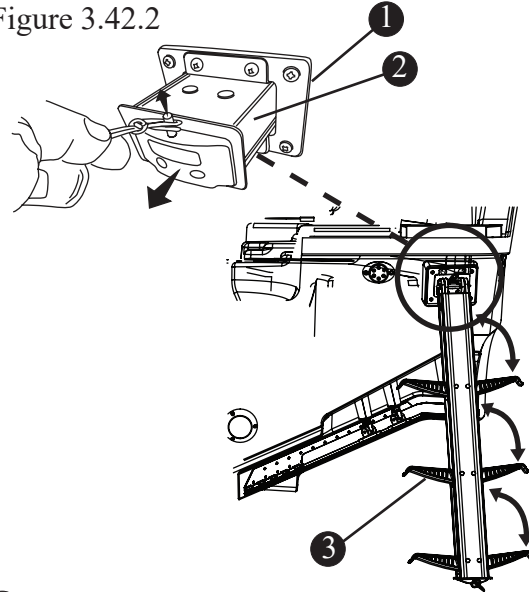

- ① TRANSOM BRACKET
- ② SWIM LADDER
- ③ COLLAPSIBLE STEPS

Collapsible Swim Ladder

The unique swim ladder can be folded and stowed into the transom cavity.

Using the Swim Ladder:

- Pull up on the latch cord to release the ladder
- Pull the ladder Completely out of the transom
- Rotate ladder downward
- Pull individual steps out of stowed position and rotate completely until seated firmly.

Upper Control Station (Option)

Figure 3.43.1

CAUTION
BRIDGE CLEARANCE
UPPER TOWER = 16 FEET

BRIDGE CAPACITY INFORMATION
MAXIMUM WEIGHT CAPACITY UNDERWAY
(PERSONS & GEAR) 450 LBS.

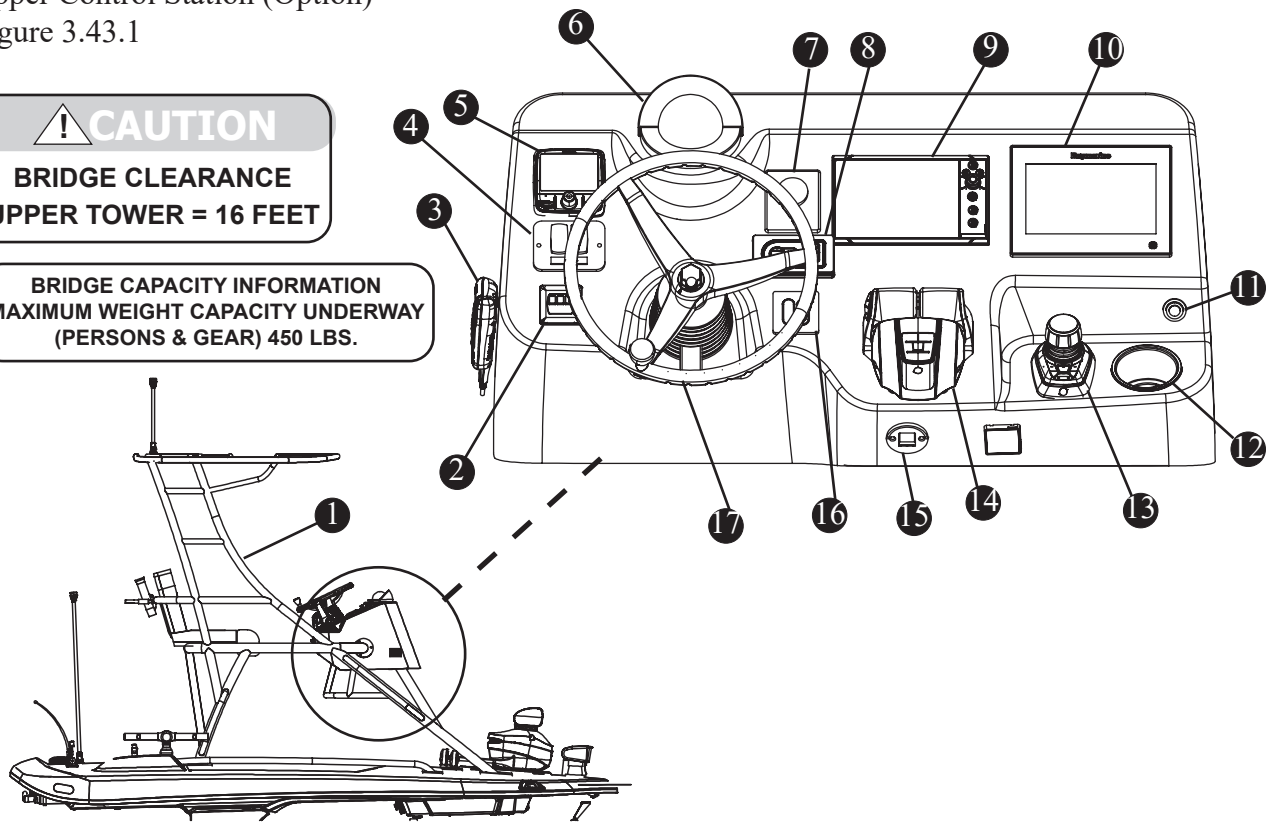

- ① UPPER STATION
- ② START/STOP SWITCH
- ③ VHF RADIO (OPTION)
- ④ HORN/OVERHEAD LIGHTS SWITCH PANEL
- ⑤ RAYMARINE AUTOPILOT
- ⑥ MAGNETIC COMPASS
- ⑦ SPOTLIGHT REMOTE (OPTION)
- ⑧ ACTIVE TRIM CONTROL (OPTION)
- ⑨ VESSELVIEW DISPLAY
- ⑩ RAYMARINE 9.5" SCREEN (GPS/CHARTPLOTTER/FISHFINDER) (OPTION)
- ⑪ 12V ACCESSORY RECEPTACLE
- ⑫ CUP HOLDER
- ⑬ JOYSTICK PILOTING (OPTION)
- ⑭ GEAR SHIFT/THROTTLE CONTROL
- ⑮ ENGINE SHUT DOWN SWITCH
- ⑯ TRIM TAB CONTROL PAD
- ⑰ STAINLESS STEEL STEERING WHEEL

Upper Control Station (Option)

Station Transfer

Station transfer allows engine control to be transferred from one control station to the other. Station transfer can be achieved by either of two methods.

NOTE: It is preferred to have the engines in neutral position when performing a station transfer. If conditions do not allow the remote controls to be placed in a neutral position, a station transfer can be made while the engines are in gear.

METHOD 1

Transfer Delay: This method delays station transfer until the control handles at the station you are transferring to match the handle positions of the station you are transferring from.

1. Press and release the TRANSFER button at the control station where you want to take control. A beep will be heard.

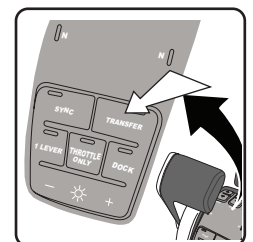

Station Transfer (Cont'd)

The neutral light will turn on.

- The lights will blink if the positions of the control handles are not aligned with the control handles at the station you are transferring from. Move the control handles until the blinking stops and the lights are solid.

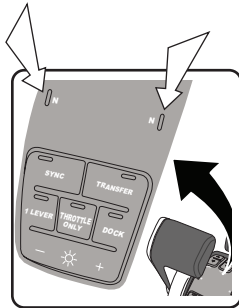

NOTE: The lights will blink faster as the handles are nearing their matched position.

- Press and release the TRANSFER button a second time. A beep will be heard. This completes the transfer.

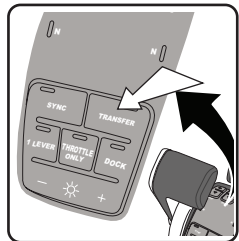

NOTE: Station transfer is cancelled if not completed within ten (10) seconds. Press and release the TRANSFER button again to re-initiate a station transfer.

- Adjust the control handles to the desired throttle and gear position.

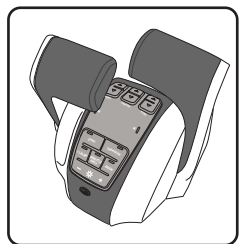

METHOD 2

Immediate Transfer: This method requires you to press the TRANSFER button twice at the control station where you want to take control. This completes the transfer. Engine speed and gear position will automatically adjust at a slow rate to the handle settings at the new active station.

- Press and release the TRANSFER button two times at the control station where you want to take control. Two beeps will be heard (one beep for each button push). This completes the transfer.

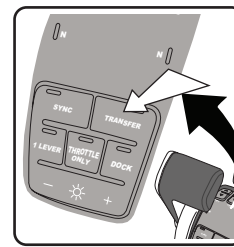

- Adjust the control handles to the desired throttle and gear positions.

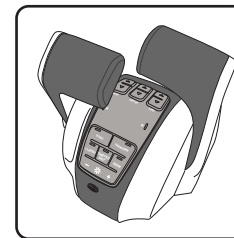

WARNING

Avoid serious injury or death from loss of boat control. The boat operator should NEVER LEAVE THE ACTIVE STATION while the engines are in gear. Helm transfer should only be attempted while both stations are manned. One person helm transfer should only be attempted while engines are in neutral.

Entertainment System

The entertainment system on your boat is a premium multi source/multi zone system with integration into the Raymarine/navigation package.

Stereo

A digital stereo, with touch screen controls, with Wi-Fi, MP3, USB and AUX input speakers throughout the boat. There are three remote control units, one located in the cabin, at the helm, and at the bow (Figure 3.45.1).

The base stereo unit is located behind a panel behind the forward lounge in the cabin.

The stereo option is iPod/iPhone and Android compatible via integrated Bluetooth and also available with optional Sirius® satellite radio receiver and antenna.

Stereo Remote
Figure 3.45.1

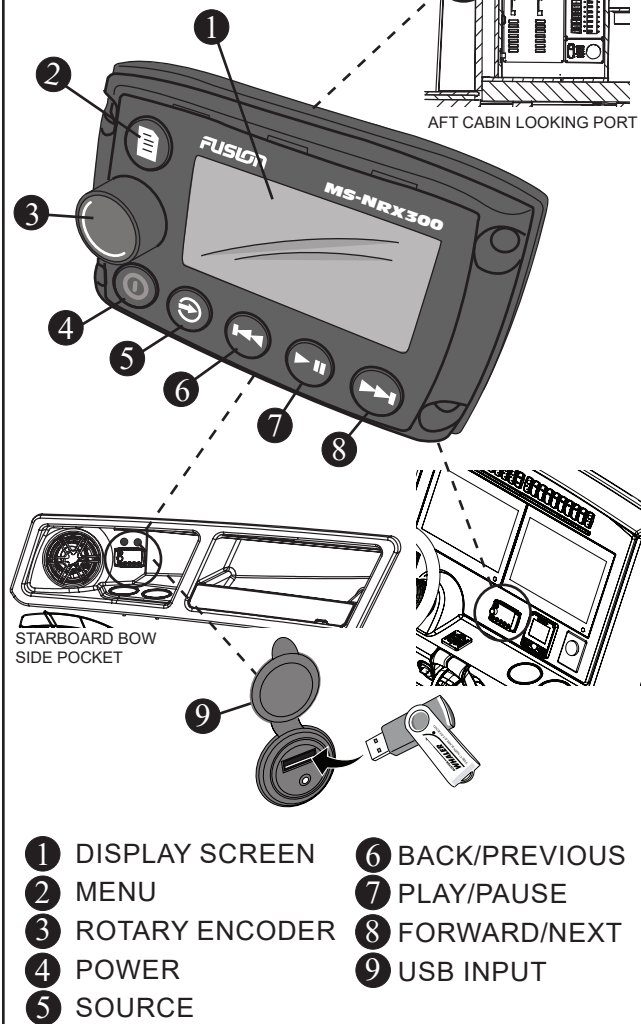

- | | |
|------------------|-----------------|
| ① DISPLAY SCREEN | ⑥ BACK/PREVIOUS |
| ② MENU | ⑦ PLAY/PAUSE |
| ③ ROTARY ENCODER | ⑧ FORWARD/NEXT |
| ④ POWER | ⑨ USB INPUT |
| ⑤ SOURCE | |

Stereo Operation Using a USB Device

- Insert the USB device into the USB input located in the starboard bow side pocket (Figure 3.45.1).
- Turn the stereo ON.
- Press the ‘source’ button and rotate the encoder to “USB”.
- Press ‘menu’ and select DISK.
Note: We recommend you name your USB device allowing the device name to be displayed. Default name of a connected device is ‘DISK’.

Courtesy Lighting

The courtesy lights placed around your boat are dual lamp (white & blue) lights which are powered by switches located on the port side of the cabin entryway, on the starboard aft gunnel, and the helm switch panel. The switches are three position switches which allow for blue or white lighting selection (see Figure 3.45.3).

Cabin Lights

The courtesy lights placed around the cabin are dual lamp (white & blue) lights which are powered by the switch on the port side of the cabin entry (See section 2 General Layout, Cabin Interior_Port).

Cabin Light Switch
Figure 3.45.2

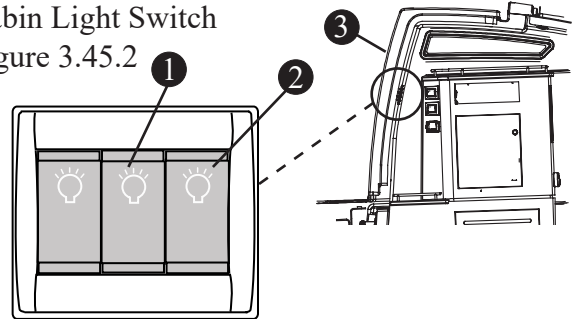

- | |
|---|
| ① CABIN OVERHEAD LIGHTS |
| ② CABIN COURTESY LIGHT SWITCH |
| - PRESS ONCE (BLUE LIGHT ON) |
| - PRESS TWICE (BLUE LIGHT OFF - WHITE LIGHT ON) |
| - PRESS THREE TIMES (ALL LIGHTS OFF) |
| ③ CABIN PORT SIDE ENTRY |

Television

Your boat is equipped with a 120V, 28” flat screen HDTV television with Apple TV and remote located on the forward wall of the cabin (see Figure 3.46.1)

NOTICE

The generator must be ON or shore power connected in order for the TV to operate.

NOTICE

WiFi connection and Apple iTunes account required for TV operation

Television
Figure 3.46.1

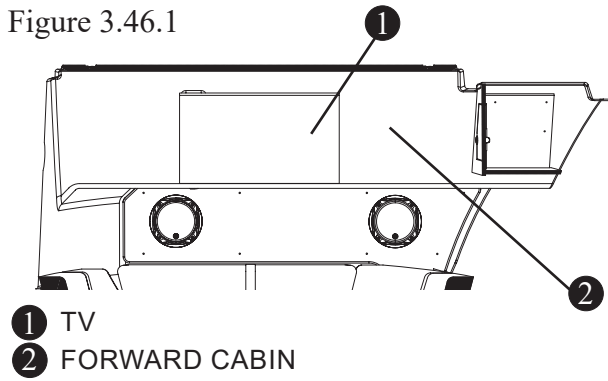

iPad with Charging Station

Your boat is equipped with both an iPad and an charging station base located on the forward facing cabinet wall of the starboard cabinet in the cabin (see Figure 3.46.2).

By mounting the iPad to the charging station, charging starts immediately. The charging station is continuously active, so that any time you attach the iPad it charges.

iPad Charging System
Figure 3.46.2

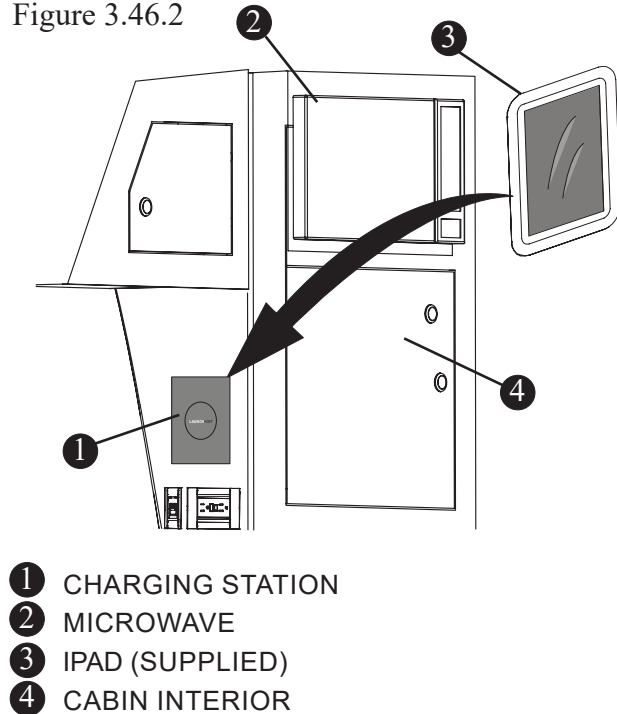

CAUTION

Do not update software, especially iOS versions on either the Raymarine navigation system, the Vessel View unit or your iPad without first contacting your dealer or Boston Whaler. To do so will negatively impact your ability to access C-Zone digital switching.

Cockpit Lighting Switch
Figure 3.46.3

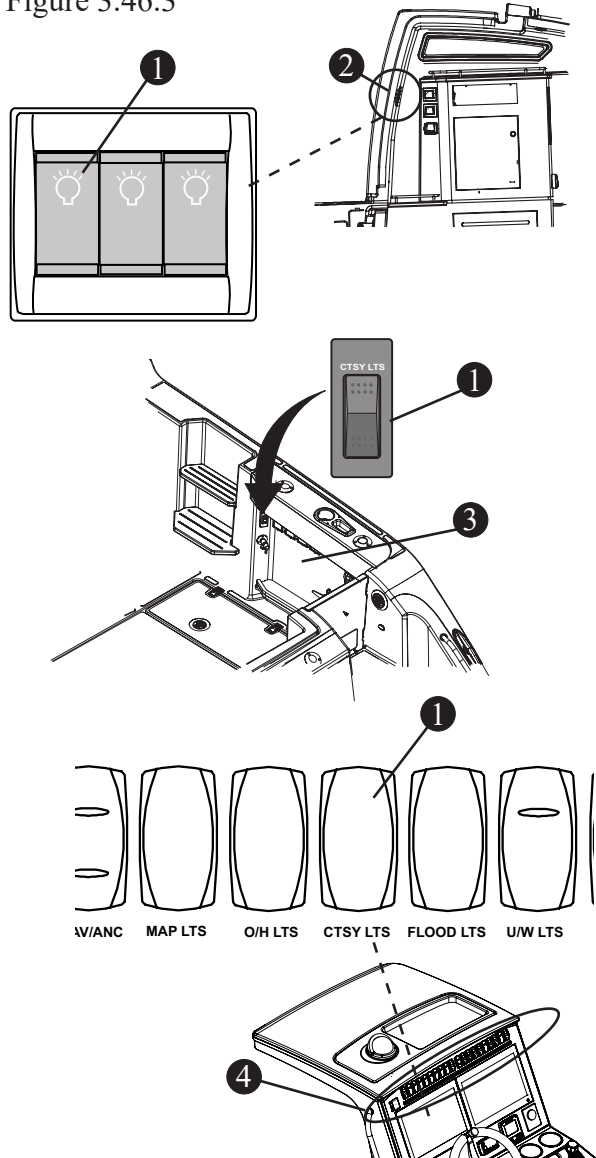

Hardtop Lighting
Figure 3.47.1

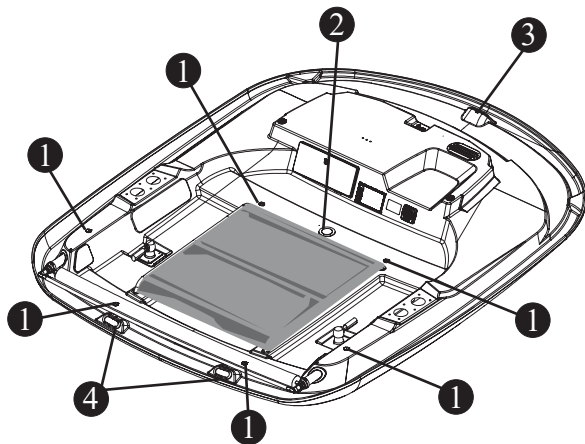

- 1 BLUE AESTHETIC LIGHTING
- 2 DUAL LAMP (RED/WHITE) MAP LIGHT
- 3 FORWARD BOW FLOOD LIGHT
- 4 AFT COCKPIT FLOOD LIGHTS

Hardtop Lighting

Blue Aesthetic lighting

The hardtop of the your boat has six blue aesthetic lights, one dual lamp (red & white) map light, one bow area flood light and two aft cockpit flood lights (Figure 3.47.1).

The blue lights are located around the underside perimeter of the hardtop. They are powered by the “O/H LTS” switch on the helm switch panel (see Figure 2.24.1).

! CAUTION

Hardtop accent lights are not to be used when navigational lights are in use as this may interfere with the effectiveness of the navigational lights.

Map Light Switch
Figure 3.47.2

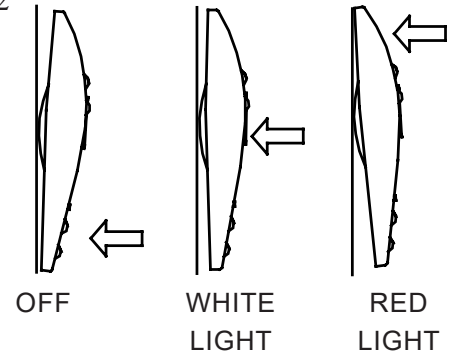

Map Lights

The dual lamp (red & white) map light directly above the console is powered by the “MAP LTS” switch on the helm switch panel (see Figure 2.24.1). The switch on the helm switch panel is a three position switch which allows for red or white lighting selection (Figure 3.47.1).

Flood Lights

The flood lights are powered by the “FLOOD LTS” switch on the helm switch panel (see Figure 3.47.3). The switch on the helm switch panel is a three position switch which allows for forward or aft lighting selection. Push the top for the forward flood and the bottom for the aft floods.

Flood Lights
Figure 3.47.3

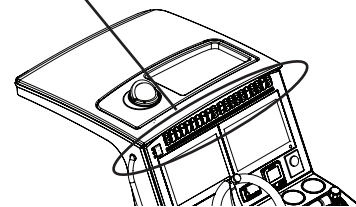
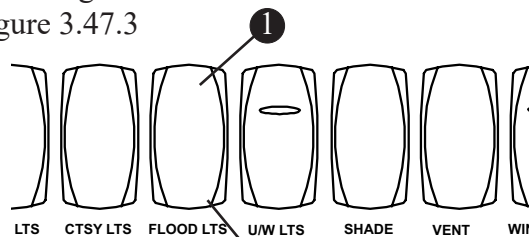

- 1 FLOOD LIGHTS SWITCH
 - PRESS ONCE (AFT FLOODS)
 - PRESS TWICE (BOTH AFT AND FORWARD)
 - PRESS THREE TIMES (FORWARD FLOOD)
 - PRESS FOUR TIMES (BOTH OFF)

Underwater Lights
Figure 3.48.1

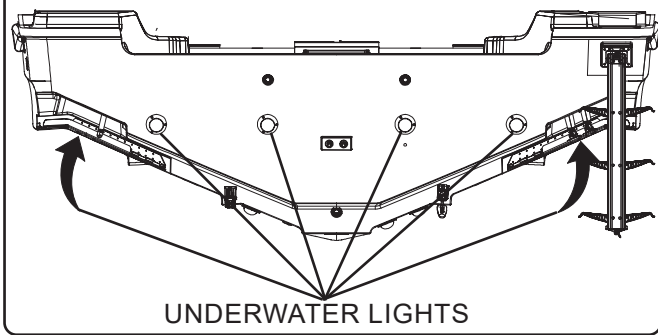

Underwater Lights (option)

If equipped, there are six blue underwater lights. Four located on the transom just below the surface of the water and two lights, one in each of the trim tab pockets on the bottom of the hull (Figure 3.47.1). When lit the lights glow which enhances the after dark experience of being on the water and in addition may on occasion attract marine life.

The underwater lights are powered by the “U/W LTS” switch on the helm switch panel (see Figure 2.24.1). The lights are protected by the “U/W LIGHTS” breaker on the DC distribution panel located on the port midship freeboard (see Figure 4.8.1).

CAUTION

Underwater lights are not to be used when navigational lights are in use as this may interfere with the effectiveness of the navigational lights.

Machinery Space Lighting

There are four white courtesy lights in the machinery space which light when the lid is raised and are turned off when the lid is closed.

Adjustable Helm Seat

The helm seat on your boat can be rotated to face the aft cockpit by lifting the latch located on the starboard side of the seat and rotating the seat. The helm seat can also be adjusted forward and aft electrically by interface with the switch located on the starboard side of the seat (Figure 3.48.2).

Adjustable Helm Seat
Figure 3.48.2

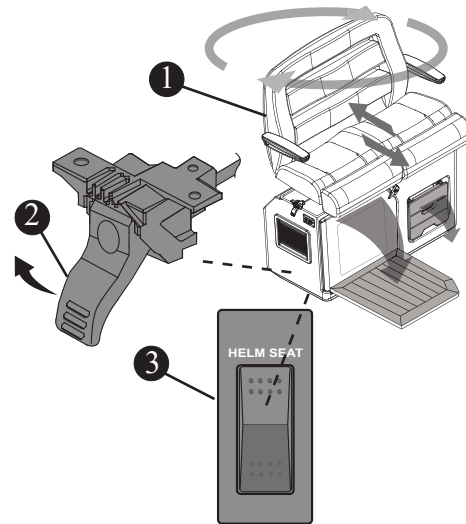

- ① ADJUSTABLE HELM SEAT
- ② ROTATION LATCH
- ③ FORWARD/AFT SWITCH

Trim Tabs

ATTENTION

Visibility from the helm station may be limited, use of trim tabs may be necessary to maintain adequate visibility in some running conditions. Avoid serious injury or death from collisions. maintain a lookout as required by USCG Navigation Rules.

Your vessel may be equipped with e trim tabs (Figure 3.24.1). The trim tabs are located on the bottom of the hull at the transom and are used to assist in leveling your vessel caused by uneven weight distribution or strong cross winds. The use of trim tabs may also increase your operator visibility, particularly during initial acceleration.

An untrimmed boat will:

- Reduce fuel economy
- Increase wear on your engine.

Trim Tab Switch
Figure 3.49.1

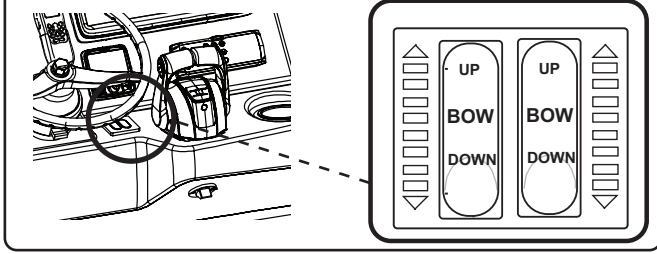

Operation

The trim tabs are controlled by rocker switches located at the helm console. Short momentary bursts of the rockers will achieve proper attitude of the hull. The trim tab switch is marked “bow up” and “bow down”.

Using the trim tabs can:

- Level the boat; fore and aft, port and starboard.
- Reduce resistance in the steering system.
- Increase speed
- Reduce strain on the engines
- Provide a smoother, more stable ride

Maintenance

The trim tabs are sealed, waterproof and maintenance free. General cleaning is recommended, and marine growth should be removed when the boat is out of the water. Also inspect the sacrificial anodes regularly and replace as necessary, refer to chapter 5 for additional information.

REFER TO OWNER'S PACKET FOR COMPLETE INSTRUCTIONS AND WARRANTY. INFORMATION.

Trim Tabs
Figure 3.49.2

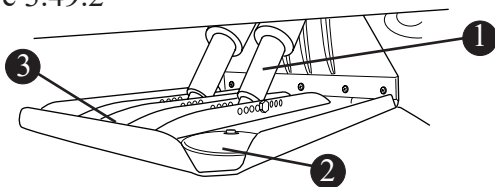

- ① LOW VOLTAGE ELECTRIC MOTOR
- ② ZINC ANODE
- ③ TRIM TAB PLANE

Auto Glide Boat Control System

The Auto Glide uses engine and GPS data to drive your boat to the most efficient running angle by adjusting the trim tabs as needed.

With the Auto Glide, your boat's running angle is measured 25 times per second. The data is used by the Auto Glide control box to:

- Automatically put your boat in the most efficient running angle.
- Reduce the amount of bow rise of your boat during hole shot mode.
- Eliminate bow porpoising (bow bounce).
- Keep your boat level at all times.

The results of these actions is a smoother ride and the best possible fuel efficiency.

Auto Glide Key Pad
Figure 3.50.1

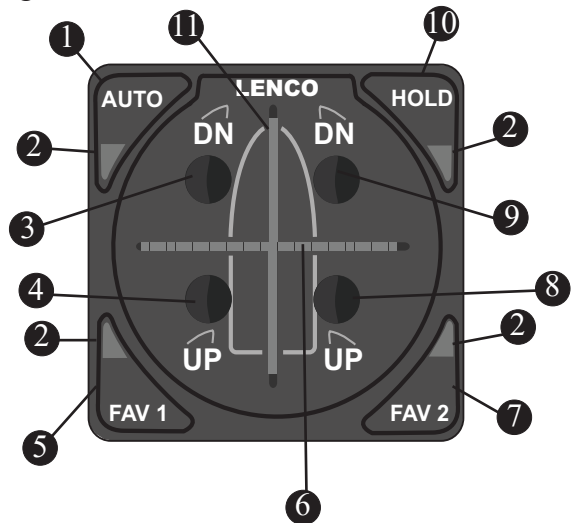

- ① “AUTO” SETTING BUTTON
- ② LED INDICATOR
- ③ PORT BOW DOWN BUTTON
- ④ PORT BOW UP BUTTON
- ⑤ FAVORITE 1 AUTOMATIC SETTING BUTTON
- ⑥ HORIZONTAL LED INDICATORS
- ⑦ FAVORITE 2 AUTOMATIC SETTING BUTTON
- ⑧ STARBOARD BOW UP BUTTON
- ⑨ STARBOARD BOW DOWN BUTTON
- ⑩ “HOLD” SETTING BUTTON
- ⑪ VERTICAL LED INDICATORS

Chapter 3 • Systems Overview & Operation

Although you will most likely keep your Auto Glide in automatic mode, you may convert to manual mode simply by pressing one of the four up/down buttons on the key pad.

REFER TO OWNER'S PACKET FOR COMPLETE INSTRUCTIONS AND WARRANTY. INFORMATION.

Gyroscopic Stabilizer (Option)

If equipped, the innovative gyro stabilizer is located in the center of the cockpit.

The stabilizer uses gyroscopic principals to reduce boat roll motions in waves and wakes independent of boat speed. The stabilizer eliminates the risk of motion sickness and safely walking around the deck in rough water.

In addition to the gyro assembly a remote display unit is located on the hardtop above the helm.

NOTICE

The generator must be ON in order for the gyro stabilizer to function.

Spool-up Time to Rated Speed - **50 minutes**

Spool-up Time to Stabilization - **35 minutes**

Full speed to zero RPM - **approx 2 hours**

! WARNING

Gyroscopic cover panels are provided to prevent personnel or equipment from contacting the gyro while it is in operation. These covers should not be stood on, or have anything placed on top. The covers should always be in place during operation. If it is ever necessary to touch the gyro while the flywheel is spinning, the gyro must be locked at the display to stop the gyro from precessing (tilting). Gyro maintenance should not be attempted unless the gyro is locked and the flywheel has stopped spinning.

REFER TO THE MANUFACTURER'S MANUAL IN YOUR OWNER'S MANUAL PACKET FOR COMPLETE INSTRUCTIONS AND WARRANTY.

Gyroscopic Stabilizer Display (Option)

Figure 3.50.1

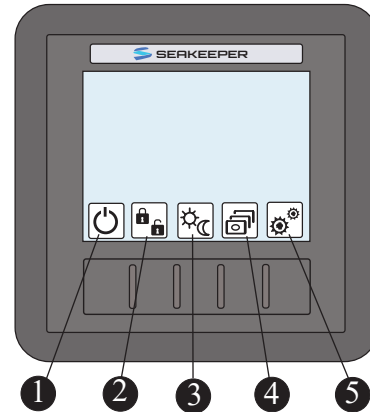

- 1 ON/OFF AND FAULT RESET
- 2 GYRO LOCK/UNLOCK
- 3 DISPLAY BRIGHTNESS (DAY/NIGHT)
- 4 SCREEN VIEWS (TOGGLE)
- 5 SETTINGS

Gyroscopic Stabilizer (Option)

Figure 3.50.2

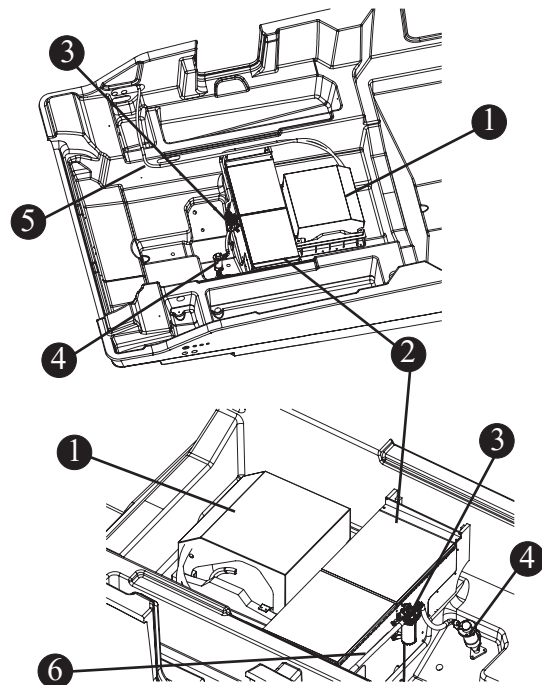

- 1 GYROSCOPIC STABILIZER
- 2 BATTERY COVER
- 3 WATER STRAINER
- 4 INTAKE SEACOCK/PUMP
- 5 TO THRU HULL OUTLET
- 6 TO GYRO INLET

Propeller

NOTICE

- **It is advised that you always carry a spare propeller, propeller hardware and propeller wrench on board. Should your propeller become damaged it can then be easily replaced.**
- **Under no circumstance should you use a propeller which allows the engine to operate at a higher than recommended RPM.**

The engines have been equipped with propellers which our tests have shown to be best suited for general use under normal conditions and load. Your boat has been propped to achieve maximum RPMs which meet Mercury requirements.

Trimming the Engines

When trimmed correctly, your boat will achieve maximum RPMs, minimize steering effort, allow for more stability and increased performance.

Trimming the engines IN full will drive the bow down causing the boat to plow through the water and will prevent the engines from achieving maximum RPMs.

Trimming the engines OUT will push the stern down and raise the bow. If OUT to far the maximum engine RPMs cannot be achieved.

A properly trimmed boat will have the bow slightly UP while running at full speed.

Different seas or operating conditions will necessitate running the boat in different trim positions. The operator will need to use his/her best judgement while boating in different conditions.

Changing Propellers

In some situations you may wish to change the propeller to give your boat slightly different performance characteristics.

In general, changing to a lower pitch propeller will increase acceleration and load pulling capability,

Propeller Assembly

Figure 3.51.1

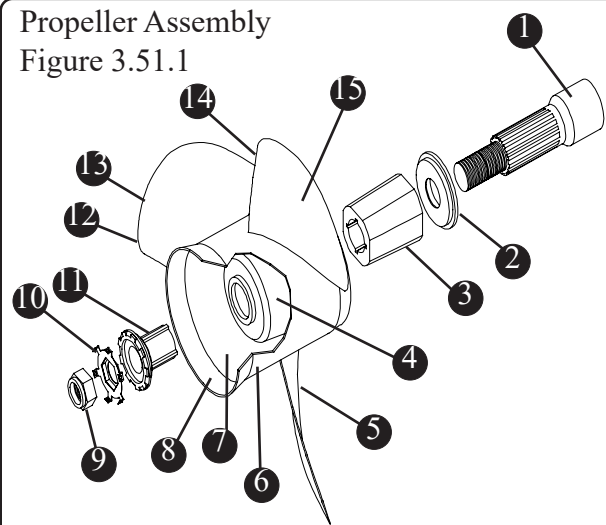

- ① ENGINE SHAFT
- ② FORWARD THRUST WASHER
- ③ DRIVE SLEEVE
- ④ INNER HUB
- ⑤ BLADE BACK
- ⑥ OUTER HUB
- ⑦ EXHAUST PASSAGE
- ⑧ DIFFUSER RING
- ⑨ PROP NUT
- ⑩ LOCK RING
- ⑪ DRIVE SLEEVE ADAPTER
- ⑫ BLADE TIP
- ⑬ LEADING EDGE
- ⑭ TRAILING EDGE
- ⑮ BLADE FACE

with a slight decrease in top end speed. If you choose to change propellers, the type should be discussed with your Boston Whaler® dealer. All propellers are designed to provide maximum forward thrust, consequently, the reverse thrust of the propeller will not be as efficient.

Propellers have two basic characteristics, diameter and pitch.

Diameter is that distance measured across the propeller hub from the outer edge of the 360° that is made by the propeller's blade during a single rotation.

Pitch is that distance in inches that a propeller will travel if rotated one revolution without any slippage.

Propeller Pitch & Diameter
Figure 3.52.1

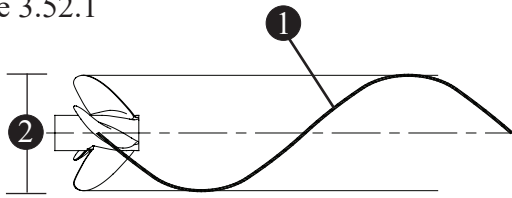

- ① PITCH
- ② DIAMETER

⚠ DANGER

Disconnect power by moving the battery switch to the "OFF" position prior to removing the propeller.

Anchor Windlass

⚠ DANGER

Use the windlass switch on the helm whenever possible. Use care when operating the anchor windlass with the hand-held remote.

The anchor windlass located at the bow gives you a mechanical means of raising and lowering the anchor.

Windlass Switches
Figure 3.52.2

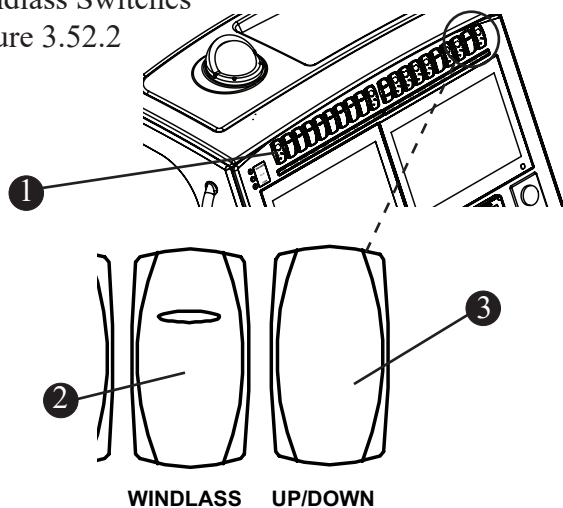

- ① HELM SWITCH PANEL
- ② WINDLASS POWER SWITCH
- ③ WINDLASS OPERATION SWITCH

The anchor windlass is controlled by switches located on the helm switch panel (see Figure 2.24.1) or by a hand held remote located in the bow locker (Figure 3.52.2/3.53.1).

The "WINDLASS" switch on the helm switch panel controls power to the windlass.

The operation switch is a momentary type switch which means that there must be constant pressure applied to the switch to operate the anchor windlass.

When not in use, the remote can be stored in a receptacle located on the aft bulkhead of the bow locker. The power source for the remote is located on the starboard side of the locker.

There is also an emergency handle which can be used to raise and lower the anchor manually in case the power to the anchor windlass is lost.

Windlass
Figure 3.52.3

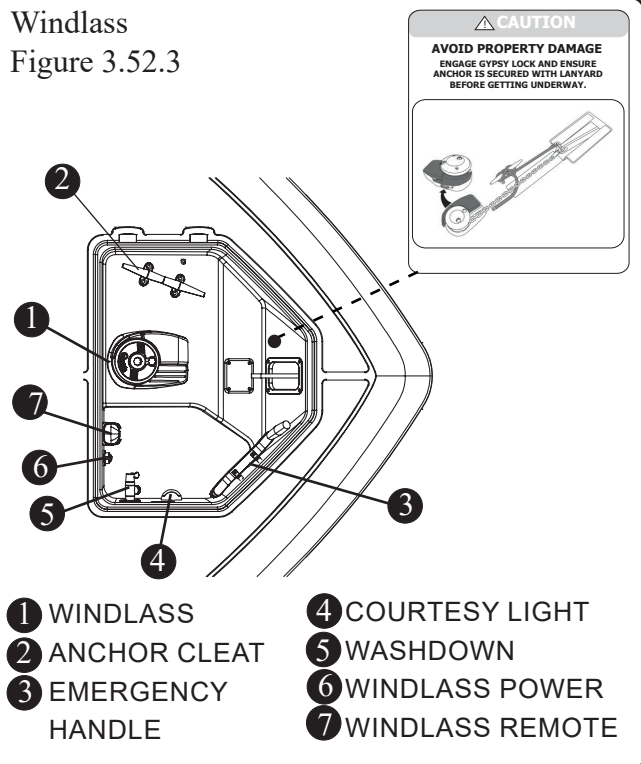

- ① WINDLASS
- ② ANCHOR CLEAT
- ③ EMERGENCY HANDLE
- ④ COURTESY LIGHT
- ⑤ WASHDOWN
- ⑥ WINDLASS POWER
- ⑦ WINDLASS REMOTE

Be sure to attach the anchor lanyard when the anchor is stowed in the bow pulpit.

NOTICE

Always secure the lanyard while underway. Failure to do so may allow accidental deployment of the anchor.

The windlass is protected by a 100 amp circuit breaker located on the DC distribution panel (See page 4-8). If there is a loss of power to the windlass, check the “WINDLASS” circuit breaker. If the breaker is tripped, reset the breaker.

If the breaker continues to trip, have the anchor windlass system checked by a qualified marine electrician.

Operation

NOTICE

Before operating the windlass be sure that the anchor lanyard is removed from the anchor and is clear of the rode as it pays out or is retrieved.

Operating From the Helm

Lowering - Pushing the top part of the switch down will power the anchor windlass DOWN. Make certain that the safety lanyard is detached from the chain and is clear of any moving parts of the anchor windlass.

Raising - Pushing the lower part of the switch will power the anchor windlass UP. Once the anchor and rode is secure in the UP position, the safety lanyard can be re-attached to the rode.

Operating From the Bow

The anchor windlass can be operated from the bow with the use of the windlass remote which is stowed in the bow locker.

WARNING

Keep hands, feet, hair and loose clothing clear of moving parts. Entanglement may cause severe bodily injury (i.e. lose of fingers or toes).

Windlass Remote

Figure 3.53.1

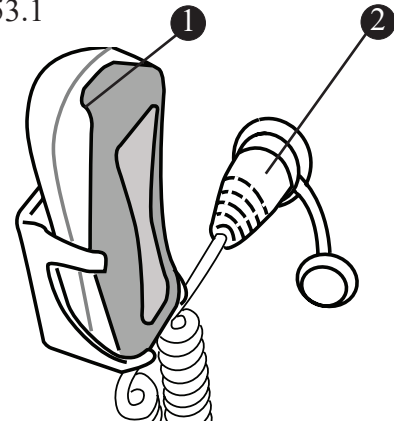

- ① HAND HELD REMOTE
- ② POWER SOURCE

⚠ DANGER

Use the anchor windlass switch on the helm when possible. Use care when operating the anchor windlass with the hand-held remote.

Anchor Windlass Remote

Figure 3.53.2

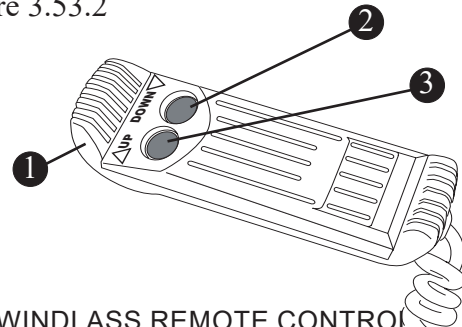

- ① WINDLASS REMOTE CONTROL
- ② “DOWN” BUTTON
- ③ “UP” BUTTON

The windlass remote is protected by a 10 amp manual reset breaker located on the battery switch panel. If there is a loss of power to the windlass remote, check the “WINDLASS CONTROL” breaker. If the breaker is tripped, reset the breaker.

- Plug the power cable into the power receptacle on the aft of the bow locker.

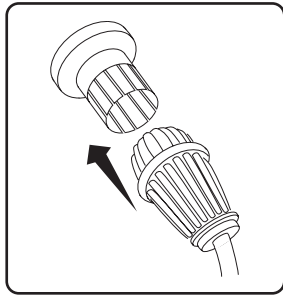

- Turn the forward portion of the plug clockwise to lock.

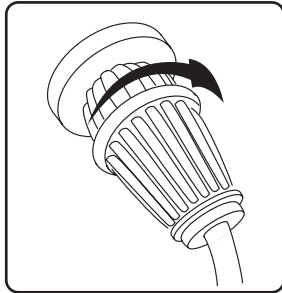

- **To raise** the anchor, press and hold on the “UP” button of the remote.

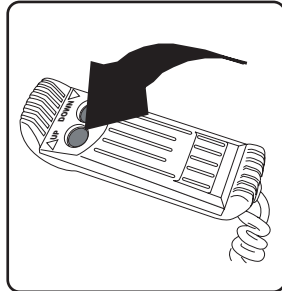

- **To lower** the anchor, press and hold on the “DOWN” button on the remote.

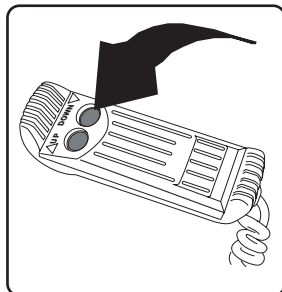

REFER TO THE MANUFACTURER'S MANUAL IN YOUR OWNER'S MANUAL PACKET FOR COMPLETE INSTRUCTIONS AND WARRANTY.

Operating The Windlass Manually

In the event that there is a loss of power to the windlass the anchor can be raised and/or lowered manually by using the emergency handle located in the bow locker.

Windlass Manual/Emergency Operation
Figure 3.54.1

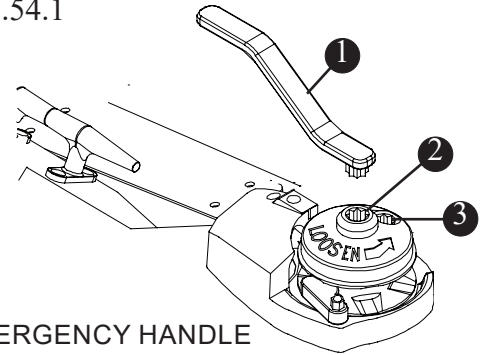

- 1 EMERGENCY HANDLE
- 2 LOOSEN WINDLASS
- 3 RAISE/LOWER ANCHOR

There are two star sockets on the top of the windlass used for manual deployment of the anchor. Inserting the emergency handle into the center socket and turning it counter-clockwise will loosen the anchor windlass chainwheel. The star socket located off-center is used for retrieving and lowering the anchor. Turning the handle counterclockwise will allow you to lower the anchor, while turning it clockwise will raise it.

When operation is complete, insert the handle into the center star socket and tighten the windlass chainwheel by rotating the handle clockwise. Be sure to attach the anchor lanyard when the anchor is stowed in the anchor davit.

Anchoring

Your boat is equipped with a windlass, anchor, rode and an anchor roller davit. Stow the anchor in the davit when not in use.

NOTE: Before using the anchor, be sure the anchor lanyard is removed and the anchor is secured to the windlass chain.

To anchor, bring the bow into the wind or current and put the engines in neutral. When the vessel comes to a stop, lower the anchor from the bow.

Considerations

- Wind and sea conditions can affect the boat.

- Because the boat is not moving through the water, there is no control.
- Be sure that the anchor will hold under all circumstances if you are leaving the boat.
- Understand the principles of rode and scope and their effect on anchor performance.

Proper anchoring requires knowledge of rode and scope and understanding the relationship between rode, scope and anchor performance.

The rode is the line connecting the anchor to the boat. Nylon line is ideal because it is light, strong and stretches, it also can be stored wet and is easy to handle. Add a length of chain between the anchor and the nylon line to prevent abrasion of the line.

The scope is technically defined as the ratio of rode length to the vertical distance from the bow to the sea floor. Scope also depends on the type of anchor, tides, winds, sea conditions and type of sea floor the anchor is in. Since you want to know how much rode to use when anchoring, use this common formula:

Rode length = (bow height + water depth) X Scope

The minimum is 5:1 for calm conditions; normal is 7:1, and severe conditions may require a 10:1.

Example:

Rode length = (3 feet + 10 feet) X 7*

Rode length = 13 feet X 7*

Rode length = 91 feet

* Scope may range from 5 to 10 or more. However, less than 5, the anchor will break out too easily.

Lowering The Anchor

- Be sure there is adequate rode.
- Secure rode to both the anchor and the boat.
- Stop the boat completely before lowering the anchor.
- Keep feet clear of lines.
- Turn on the anchor light when at anchor or drifting (not under power) at night or in low visibility.

NOTE: If using the windlass, refer to the windlass operator's manual for anchoring instructions

Setting the Anchor

There is no best way to set an anchor. Experiment to see how it performs. One method is to turn the rode around a bitt or a cleat and slowly pay out as the boat backs from the anchor site. When the proper scope has been reached snub the rode quickly, causing the anchor to dig in to the sea bottom.

- Reverse the engine slowly to drive the anchor in and to prevent it from dragging.
- Secure the rode to the bitt or cleat.

Weighing the Anchor

To weigh (or retrieve) the anchor, start the boat and run slowly up to the anchor, taking up the rode as you go. The anchor will usually break out when the rode becomes vertical. Coil lines to let them dry before stowing.

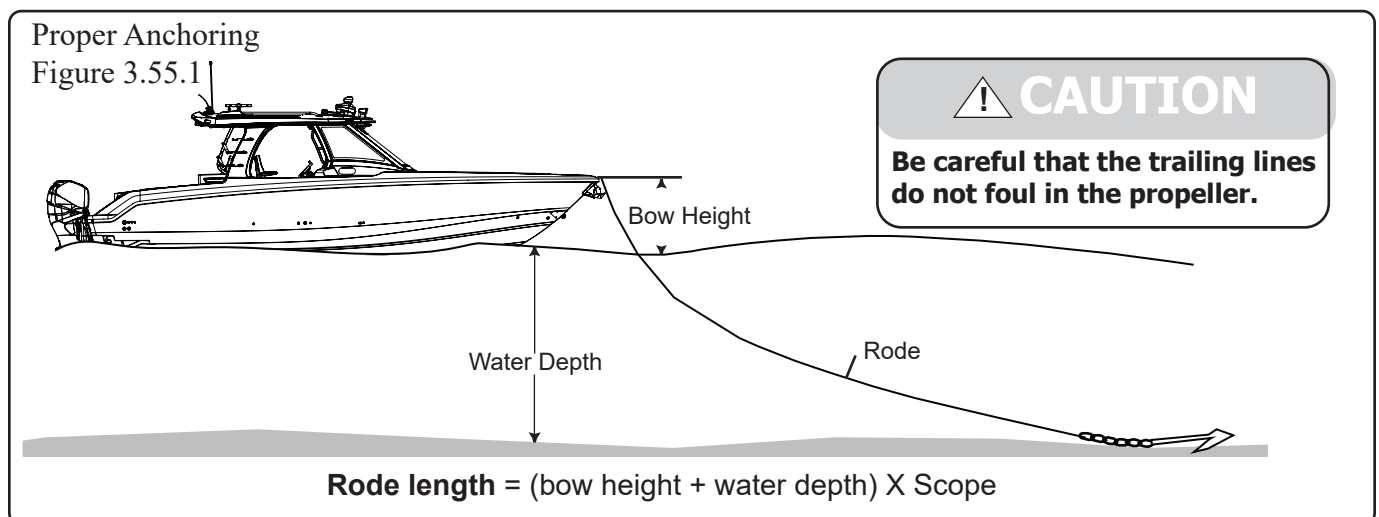

THIS PAGE INTENTIONALLY LEFT BLANK

Electrical Systems

DC Electrical System

This vessel is equipped with an electrical system powered by a series of batteries. The batteries are charged by running the generator or when the engines are running or can be charged by shore power when the engines and generator are off.

A battery charger located on the starboard wall of the bilge (see Figure 4.2.1) facilitates the charging of the batteries when using shore power. See Chapter 3 for shore power operation.

The electrical system utilizes selector switches to control the delivery of power to the following:

- Engine Ignition.
- Engine tilt trim system
- Helm switch panel and helm instrument panel
- Lighting/Navigation systems
- Livewell system
- Add-on accessories and electronics

Batteries

⚠ DANGER

Batteries contain sulfuric acid which is dangerous and can cause serious injury. AVOID contact with skin, eyes and clothing. If contact occurs, immediately flush the affected area with large quantities of water and call for medical assistance.

NOTICE

Always store the batteries in the battery trays. Tighten the knobs on the top of the trays to keep the batteries secure.

NOTICE

Refer to your engine owner's manual for exact battery requirements.

The chart below is provided for reference purposes only. Use only AGM batteries with Verado engines.

Application	Group	Volts	MCA*	RC 25	Qty.**
USA (SAE)	31	12	800	135 min	3

* Marine Cranking Amps

** Gyroscopic Option includes additional fourth battery

Application	Group	Volts	CCA*	Reserve	Qty.**
Intn'l (EN)	31	12	975	65Ah	3

* Cold Cranking Amps

** Gyroscopic Option includes additional fourth battery

NOTICE

Ensure that your batteries meet Mercury's AGM and CCA requirements

Battery Trays

The battery trays, located in the bilge, house and secure the batteries. Your batteries should always be secured in the battery trays provided with your boat and secured in place by the retaining brackets. The trays will ensure that while underway the batteries will not move around, thus causing damage to components fitted in the same area.

The batteries can be removed from the trays by first removing the negative wires from the terminal posts followed by removing the positive wires then removing the retaining lid on the battery tray.

Standard Battery Locations

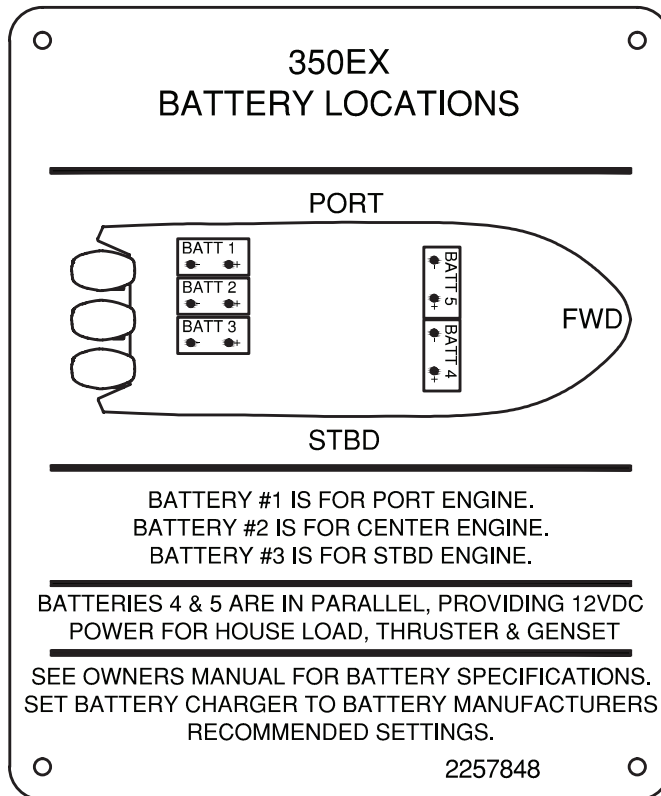

Gyroscopic Stabilizer Battery Locations (Option)

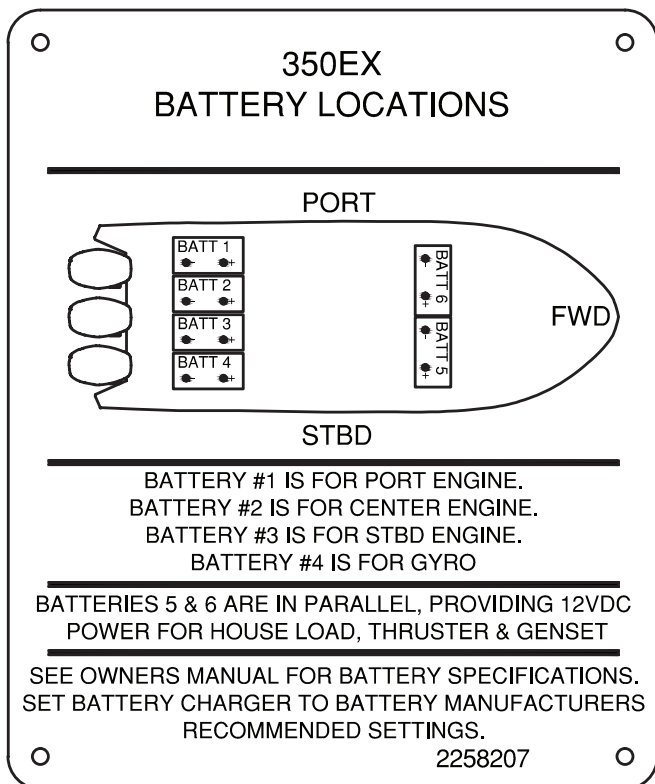

Battery Trays (Gyroscopic Stabilizer Option)
Figure 4.2.2

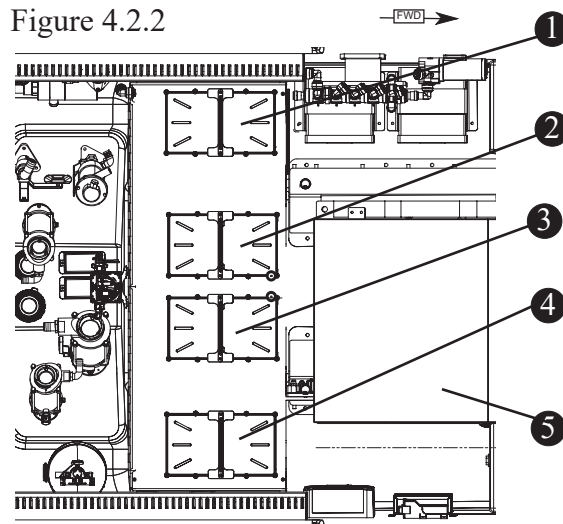

- 1 PORT ENGINE BATTERY TRAY
- 2 CENTER ENGINE BATTERY TRAY
- 3 STARBOARD ENGINE BATTERY TRAY
- 4 GYROSCOPIC STABILIZER BATTERY TRAY
- 5 GYROSCOPIC STABILIZER

Battery Trays
Figure 4.2.1

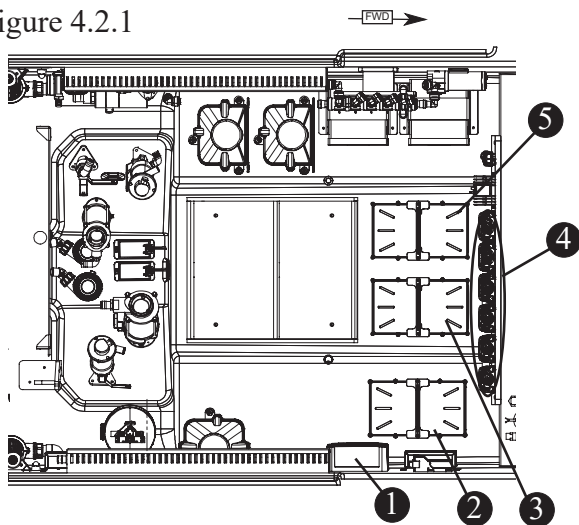

- 1 AFT BATTERY CHARGER
- 2 STARBOARD ENGINE BATTERY TRAY
- 3 CENTER ENGINE BATTERY TRAY
- 4 BATTERY REMOTE SWITCHES AND
AUTOMATIC CHARGING RELAYS (ACR)
- 5 PORT ENGINE BATTERY TRAY

CAUTION

- **Never use an open flame in the battery storage area.**
- **Avoid striking sparks near the battery.**
- **A battery will explode if a flame or spark ignites the free hydrogen given off during charging.**
- **The battery should always be disconnected before doing any work or maintenance on the electrical system.**
- **If equipped with a battery switch, you will need to stop the engine before moving the switch to the "OFF" position.**

Battery Charger

The battery charger, mounted on the starboard side of the bilge (see Figure 4.2.1) automatically increases current output when there is a drop in battery voltage. When the batteries are charged, the unit maintains a small current flow to keep the batteries fully charged and ready for service without overcharging.

Charge Rate

The battery charger has selectable profiles that affect the charge rate. The charge rate profile is pre-set at the factory to AGM to match the battery type

installed in your vessel. Matching the charge rate to the battery type extends battery life and maximizes battery performance.

Overload Protection

If an electrical short or overload occurs in the electrical system the charger will reduce its output voltage to avoid internal damage. When an electrical short occurs, the red LED on the front panel of the unit will be illuminated. The overload or short must be removed in order for the charger to resume charging characteristics.

Maintenance

The charger is fully automatic and requires no maintenance. However, the battery terminals should be cleaned periodically with baking soda and all connections tightened to provide trouble free operation.

Battery Switches

Your boat uses battery switches (one for each engine) to control delivery of DC power from the batteries. These battery switches are advanced electric relay switches located on the forward bulkhead in the bilge and are actuated via a rocker switch on the DC distribution panel (see Figure 4.8.1).

The DC distribution panel is located behind an access door on the port freeboard opposite the control station.

CAUTION

You must stop the engine(s) before moving the battery switch(es) to the "OFF" position.

When the engines are shut down or not providing a charge, the boats systems will draw power from the forward batteries (see Figure 4.5.1). This will allow you to run all the boats functions without affecting the engine's batteries.

Remote Battery Switches

Each battery switch on the DC Distribution panel (see Figure 4.8.1) is wired to a remote switch located on the forward bulkhead in the bilge (see Figure 4.4.1).



Automatic Charging Relays (ACR)

Batteries are automatically connected in parallel through the use of ACRs (Automatic Charging Relay) when a sufficient charging source is present. The battery banks are automatically separated when the charging source falls below a certain voltage level for a predetermined amount of time.

The use of ACRs eliminates the need for the operator to monitor battery voltage and decide whether or not it is ok to parallel the battery banks. It also eliminates the chance of a dead battery bank if a paralleling switch were left in the "Combined" position without a sufficient charging source present. In an emergency, the operation of the ACRs can be manually overridden by use of the knob on the top of the ACR.

Manual Control Override

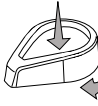
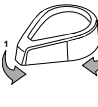
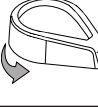
Each of the remote battery switches and ACR units have a manual override knob on the top of the unit as an added level of safety that allows manual ON-OFF control with or without power and provides LOCK OFF for servicing of the electrical system (See chart at the top of right column).

Manual Control Override Knob Operation		
To combine battery banks	With Override Knob in (REMOTE position) push button until latched (Push to latch ON).	
To isolate battery banks that are connected	Rotate Override Knob to right to release button from latch ON mode (button pops up). Rotate Override Knob to left (REMOTE position).	
To prevent remote operation.	Rotate Override Knob to right (LOCK OFF position).	
To secure for servicing.	With Override Knob in (LOCK OFF position), pass cable tie through hole.	

REFER TO THE MANUFACTURER'S MANUAL IN YOUR OWNER'S MANUAL PACKET FOR COMPLETE INSTRUCTIONS, WARRANTY AND SAFETY INFORMATION.

Remote Battery Switches and ACRs

Figure 4.4.1

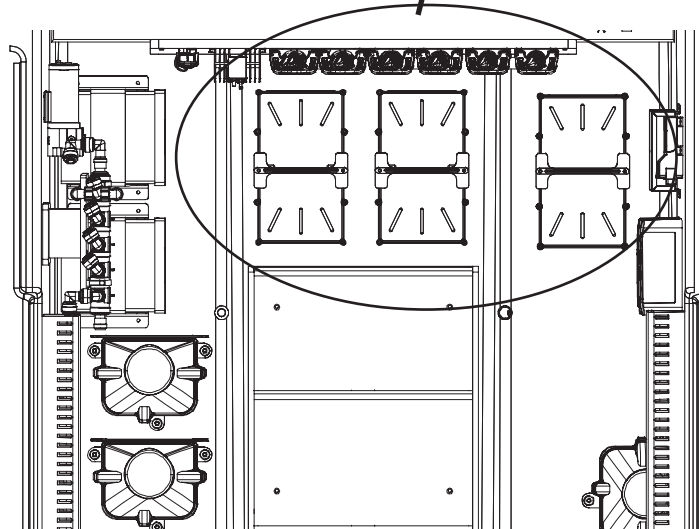
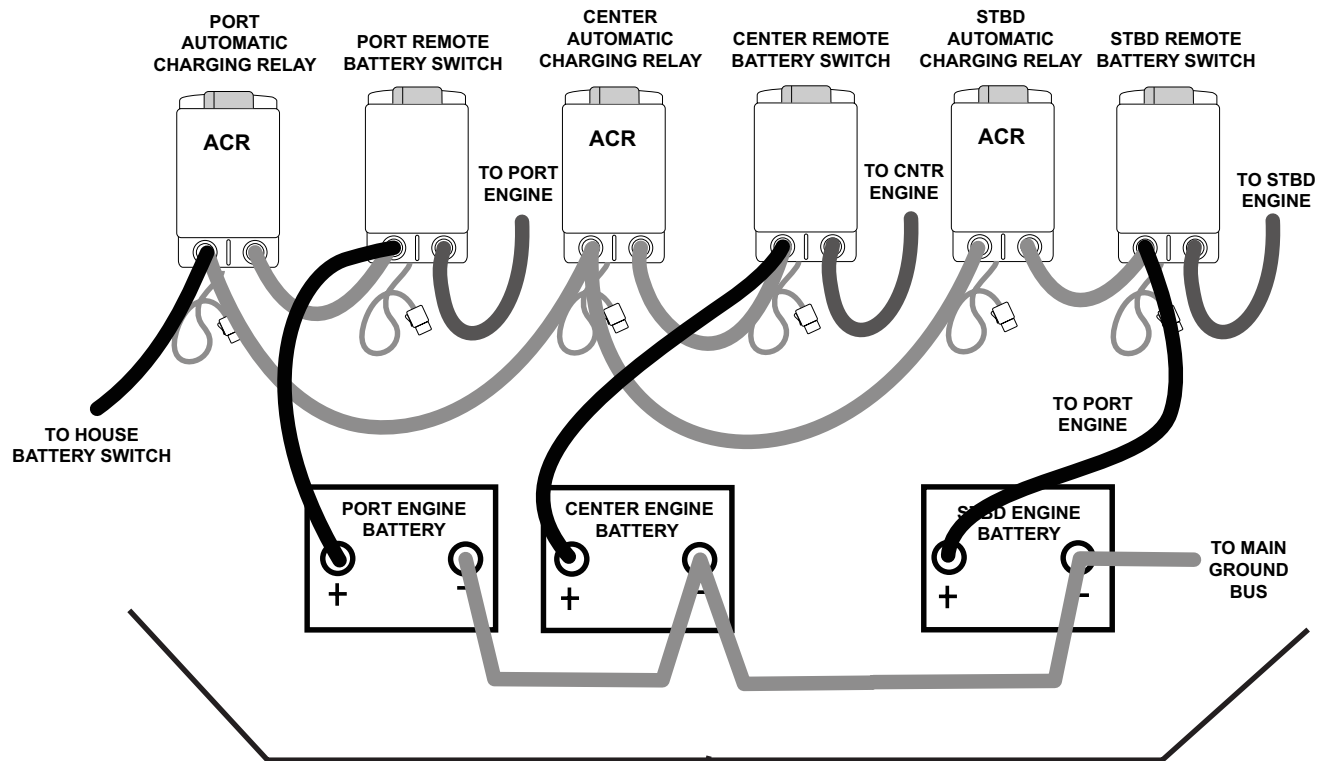

House Battery Trays

There are battery trays, for the two batteries in parallel which provide the 12 volts necessary to power the house load, the bow thruster, and the generator along with a battery switch and battery charger. Access can be made through forward bunk base in the cabin.

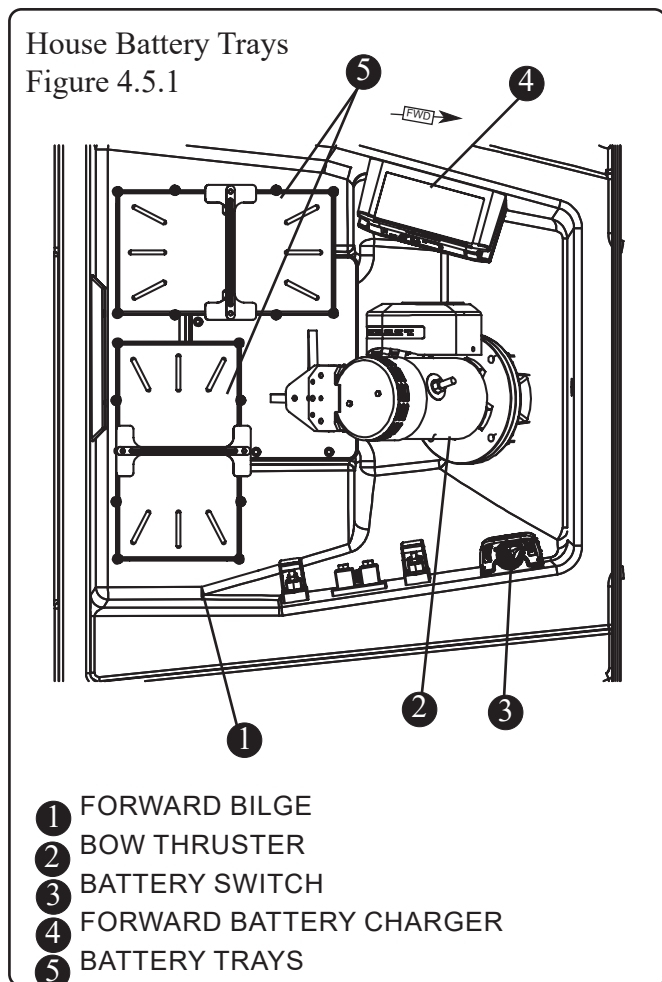

The chart below is only a recommendation. Refer to your bow thruster owner's manual for exact battery requirements. **Use only AGM batteries with Verado engines.**

Application	Group	Volts	MCA*	RC 25	Qty.
USA (SAE)	31	12	800	135 min	2

* Marine Cranking Amps

NOTICE

Ensure that your batteries meet Mercury's AGM and CCA requirements

Battery Maintenance

Before use, check each battery and the charging system for loose connections or wiring. Normal

maintenance should include:

- Coat the terminals with dielectric grease
- Keep the batteries dry
- Remove the batteries from the boat during cold weather or long term storage.

The most life shortening experience for the battery is to be drained to zero charge before recharging.

When a battery discharges, the active material on both positive and negative plates converts to lead sulfate, causing the plates to become more alike in an electrical charge. The electricity conducting battery acid becomes weaker and the voltage drops. As the battery remains discharged, the process continues until recharging the battery becomes impossible.

If the battery does become run down be sure to recharge it as soon as possible. Over charging the battery can be just as detrimental to its life as running it down too far.

12 Volt Accessory Receptacles

NOTICE

DO NOT insert a cigarette lighter into the 12V receptacles. Damage to the unit and system may occur.

Your boat is equipped with four 12 volt accessory receptacles. One each receptacle is located in the port and starboard bow storage pockets, another is located in the console storage tray and another is located in the upper storage cabinet on the port aft cabin (see Figure 4.6.1).

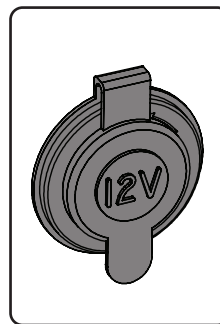

These receptacles are made of corrosion resistant marine grade materials and have a moisture proof cap. The receptacles are protected by the 24HR breaker on the DC distribution breaker panel. (see Figure 4.8.1).

Be sure to use accessories that do not exceed the rated capacity of the circuit, (10 amps).

12V receptacles
Figure 4.6.1

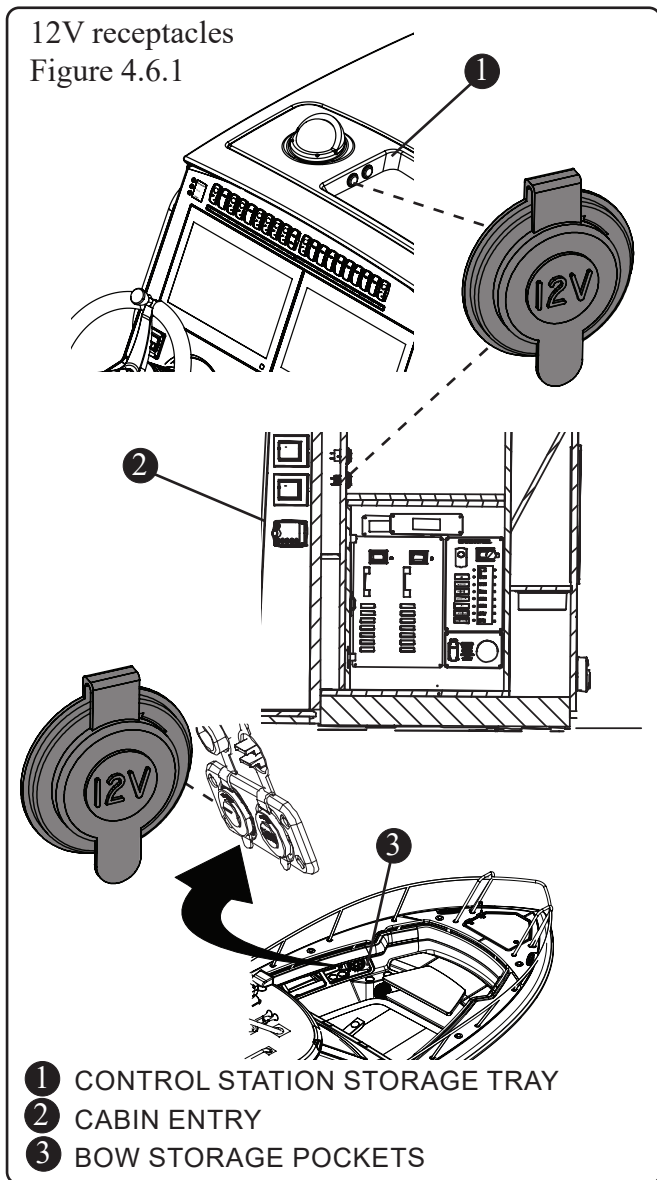

120 Volt Receptacles

Your boat is equipped with three 120 volt receptacles. One each located on the starboard and port side of the prep station. Another located on the aft wall of the head.

The receptacles can be used while the generator is running or while connected to shore power (see Chapter 3).

The outlets are protected by a breaker on the 120V AC Distribution Panel located in the cabin (Figure 4.10.1).

120V receptacles
Figure 4.6.2

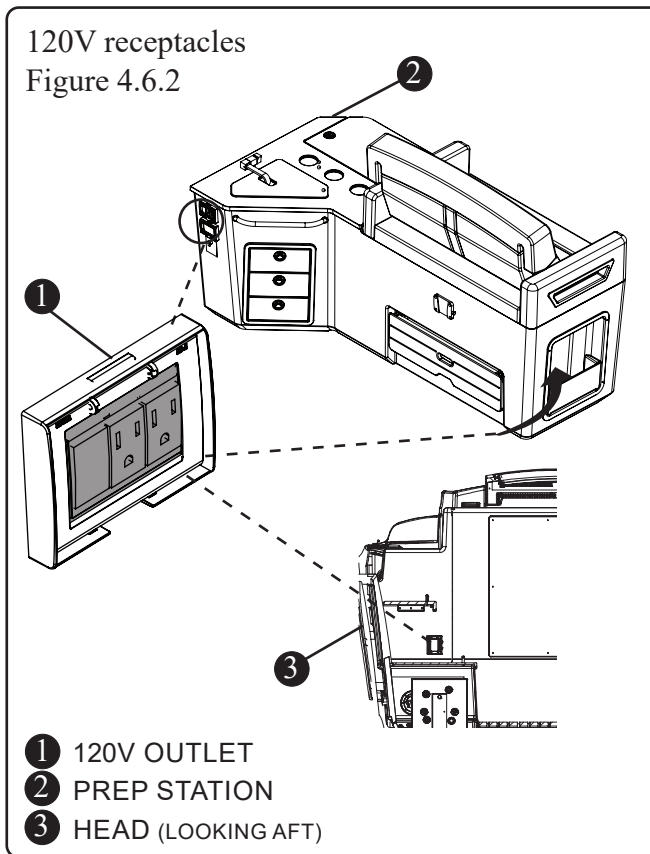

Theft Deterrent System (TDS)/Whaler Watch w/Remote Connectivity*

Your vessel is equipped with the following features:

- Anti-theft security key fob with engine immobilization
- Boston Whaler proprietary vessel monitoring system
- Cellular and satellite 24-hour monitoring system providing world-wide coverage
- Monitor tanks, batteries, shore power and high-water sensor
- Telematics tracking system with GeoFence alert notification

*A limited subscription is included and thereafter the service is subscription based. To access the system remotely go to www.whalerwatch.net

REFER TO MANUFACTURER'S MANUAL IN OWNER'S PACKET FOR COMPLETE INSTRUCTIONS AND WARRANTY INFORMATION.

Main DC Breaker Panel

Your boat's DC electrical system operates on 12V power supplied by the two forward batteries (see Figure 4.5.1).

The DC breaker panel is located in a cabinet on the aft port side of the cabin (see Figure 2.18.1)

Main DC Panel
Figure 4.7.1

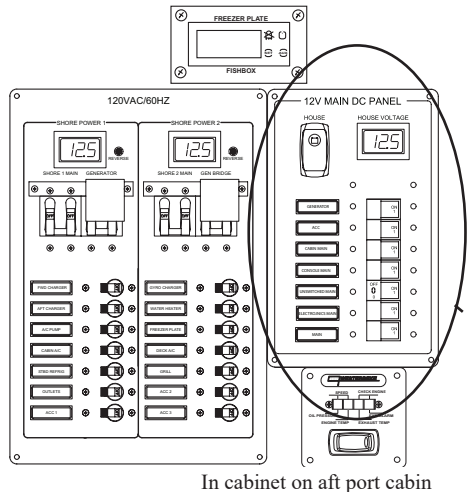

In cabinet on aft port cabin

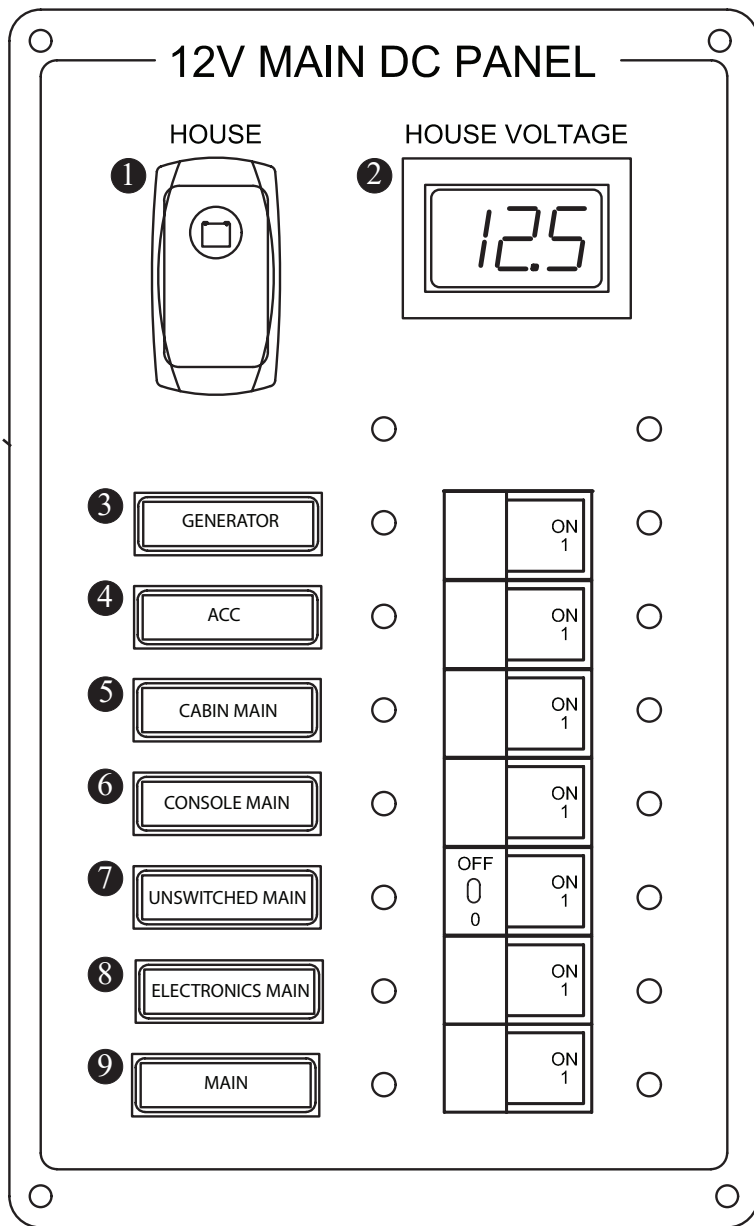

- ① HOUSE BATTERY SWITCH
- ② VOLTAGE METER
- ③ GENERATOR..... 125 AMPS
- ④ ACC..... 10 AMPS
- ⑤ CABIN MAIN 80 AMPS
- ⑥ CONSOLE MAIN 50 AMPS
- ⑦ UNSWITCHED MAIN 40 AMPS
- ⑧ ELECTRONICS MAIN..... 60 AMPS
- ⑨ MAIN..... 150 AMPS

DC Distribution Panel

The DC distribution panel is located on the port midship gunwale.

DC Distribution Panel 12V

Figure 4.8.1

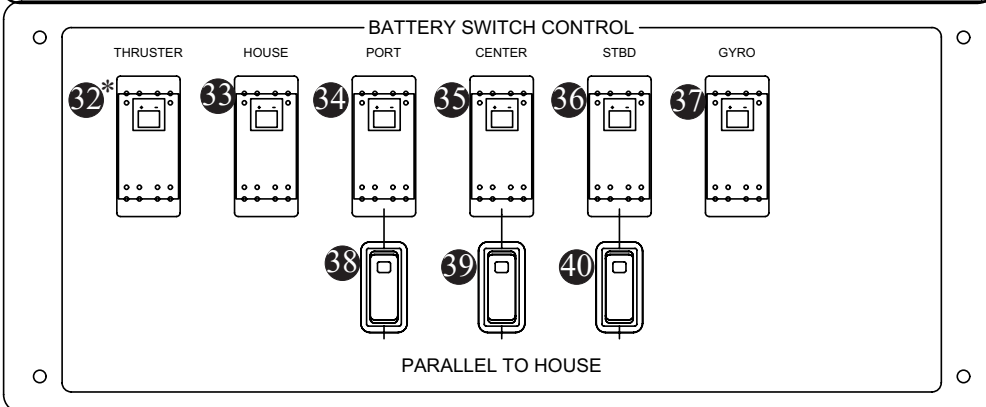
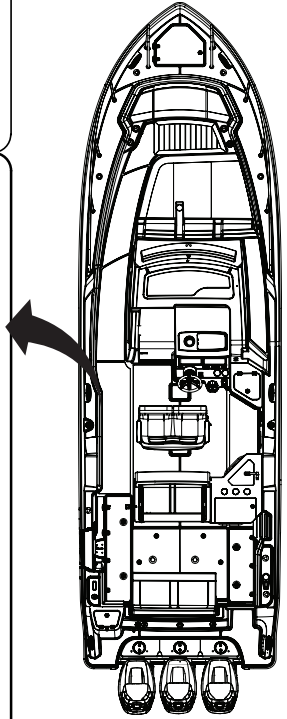
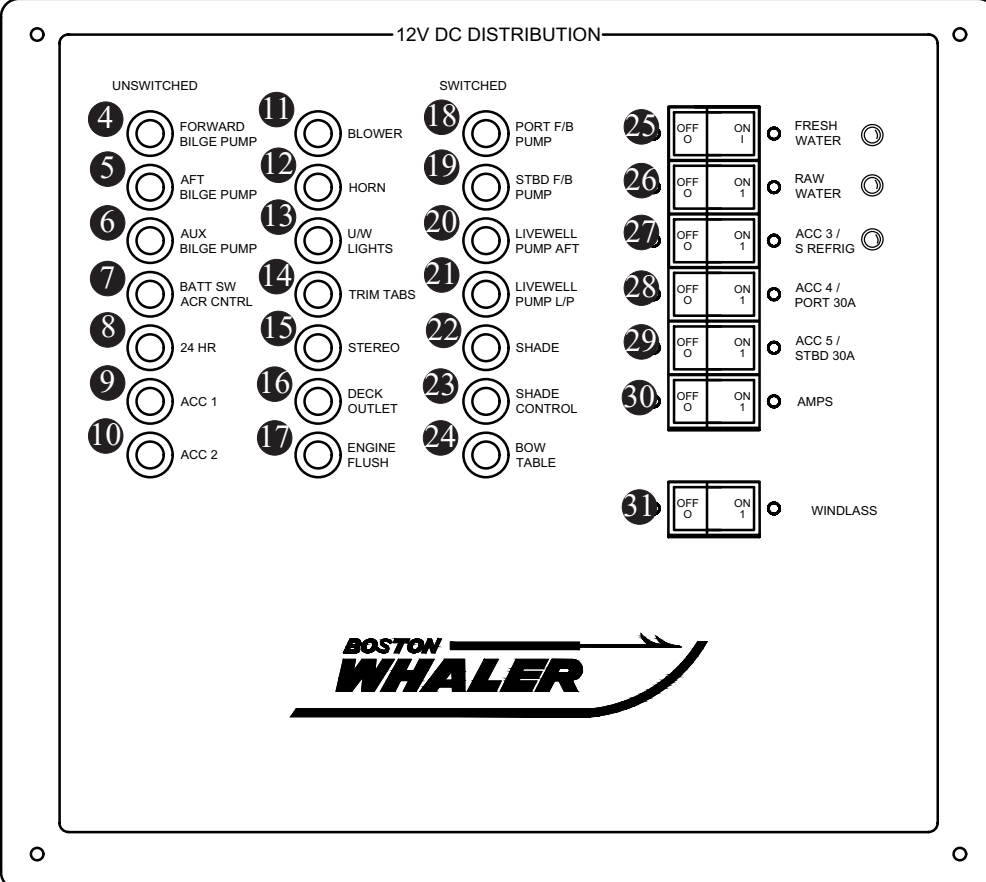
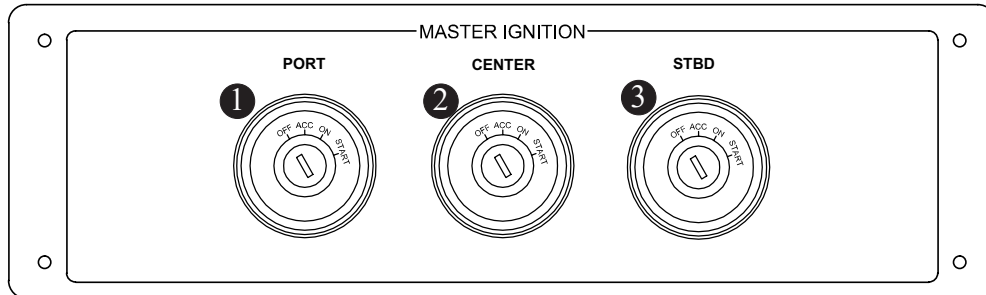

* Thruster switch deleted with Joystick Piloting option.

DC Distribution Panel

Figure 4.9.1

- ① PORT ENGINE IGNITION
- ② CENTER ENGINE IGNITION
- ③ STARBOARD ENGINE IGNITION
- ④ FORWARD BILGE PUMP 6 AMPS
- ⑤ AFT BILGE PUMP 12 AMPS
- ⑥ AUXILIARY BILGE PUMP 12 AMPS
- ⑦ BATTERY SWITCH/ACR CONTROL 10 AMPS
- ⑧ 24 HR 5 AMPS
- ⑨ ACC 1 5 AMPS
- ⑩ ACC 2 5 AMPS
- ⑪ BLOWER 7 AMPS
- ⑫ HORN 10 AMPS
- ⑬ UNDERWATER LIGHTS 25 AMPS
- ⑭ TRIM TABS 20 AMPS
- ⑮ STEREO 15 AMPS
- ⑯ DECK OUTLET 15 AMPS
- ⑰ ENGINE FLUSH 15 AMPS
- ⑱ PORT F/B PUMP 10 AMPS
- ⑲ STBD F/B PUMP 10 AMPS
- ⑳ AFT LIVEWELL PUMP 15 AMPS
- ㉑ LP LIVEWELL PUMP 6 AMPS
- ㉒ SHADE 15 AMPS
- ㉓ SHADE CONTROL 5 AMPS
- ㉔ BOW TABLE 15 AMPS
- ㉕ FRESH WATER PUMP 15 AMPS
- ㉖ RAW WATER PUMP 15 AMPS
- ㉗ ACC3/STBD REFRIGERATOR 15 AMPS
- ㉘ ACC4/PORT 30A RECEPTACLE 30 AMPS
- ㉙ ACC5/STBD 30A RECEPTACLE 30 AMPS
- ㉚ AMPS 150 AMPS
- ㉛ WINDLASS 100 AMPS
- ㉜ BOW THRUSTER BATTERY SWITCH*
- ㉝ HOUSE BATTERY SWITCH
- ㉞ PORT ENGINE BATTERY SWITCH
- ㉟ CENTER ENGINE BATTERY SWITCH
- ㊱ STARBOARD ENGINE BATTERY SWITCH
- ㊲ GYRO STABILIZATION (OPTION)
- ㊳ PORT ENGINE BATTERY/HOUSE BATTERY PARALLEL SWITCH
- ㊴ CENTER ENGINE BATTERY/HOUSE BATTERY PARALLEL SWITCH
- ㊵ STARBOARD ENGINE BATTERY/HOUSE BATTERY PARALLEL SWITCH

* Thruster switch deleted with Joystick Piloting option.

Main AC Breaker Panel

The panel is located in a cabinet on the aft port side of the cabin (see Figure 2.18.1)

AC Distribution Panel

Figure 4.10.1

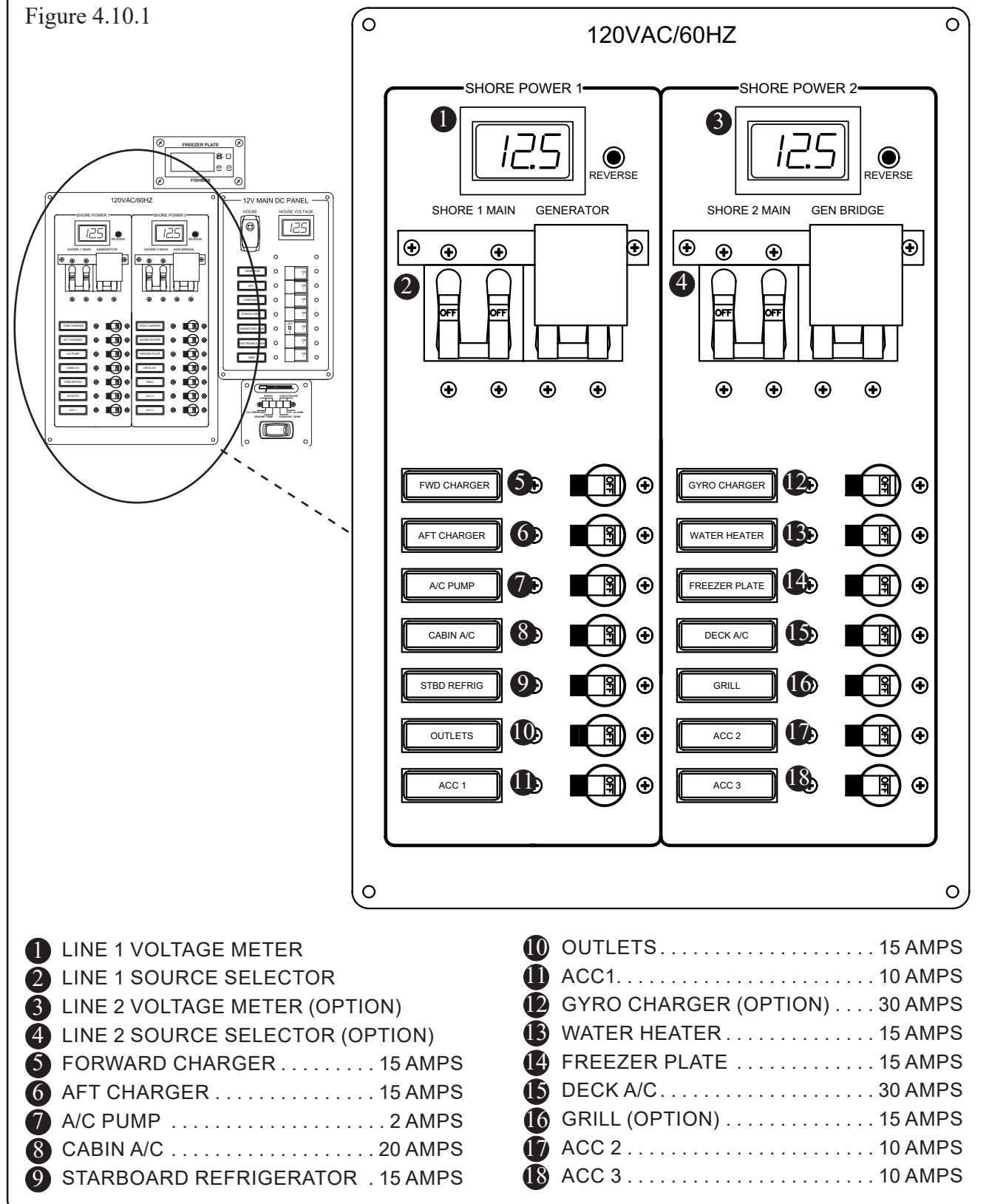

- | | |
|-------------------------------------|---------------------------------------|
| ① LINE 1 VOLTAGE METER | ⑩ OUTLETS 15 AMPS |
| ② LINE 1 SOURCE SELECTOR | ⑪ ACC1 10 AMPS |
| ③ LINE 2 VOLTAGE METER (OPTION) | ⑫ GYRO CHARGER (OPTION) . . . 30 AMPS |
| ④ LINE 2 SOURCE SELECTOR (OPTION) | ⑬ WATER HEATER 15 AMPS |
| ⑤ FORWARD CHARGER 15 AMPS | ⑭ FREEZER PLATE 15 AMPS |
| ⑥ AFT CHARGER 15 AMPS | ⑮ DECK A/C 30 AMPS |
| ⑦ A/C PUMP 2 AMPS | ⑯ GRILL (OPTION) 15 AMPS |
| ⑧ CABIN A/C 20 AMPS | ⑰ ACC 2 10 AMPS |
| ⑨ STARBOARD REFRIGERATOR . 15 AMPS | ⑱ ACC 3 10 AMPS |

AC Electrical System

Your boat's AC electrical system operates on 120/30A power from the generator or shore power. See Chapter 3 for information regarding the operation of your generator and Chapter 3 for information regarding the operation of the shore power system. The AC distribution panel is located in a cabinet on the aft port wall of the cabin.

Component Breakers

Your boat utilizes manual reset breakers for the various components throughout the boat. The breakers can be found on panels located in various places on your boat (Figure 4.7.1 through 4.10.1).

If a component breaker trips, determine and correct the problem before resetting the breaker. Should a circuit breaker trip repeatedly, have a qualified marine electrician determine and correct the cause of the trip.

In the event it is necessary to replace a breaker, use only the same amperage as the original. If a breaker is replaced with one of lower amperage, it will not be sufficient to carry the electrical load of the equipment it is connected to and will cause nuisance breaker tripping. Conversely, if a breaker is replaced with one of higher amperage, it will not provide adequate protection against an electrical malfunction and will create a fire hazard.

WARNING

Use of higher amperage fuses or breakers is a fire hazard.

Fuse Blocks

WARNING

Use of higher amperage fuses or breakers is a fire hazard.

Use fuses and breakers having the same amperage rating as the original or as specified.

There are four fuse blocks on your boat.

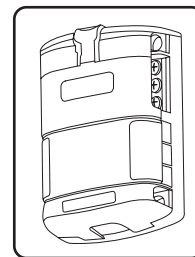

• **The unswitched fuse block** is located on the aft wall of the electronics bay and can be accessed through a panel behind the port cabin lounge.

1 - FWD BILGE PUMP	6 AMPS
2 - AFT BILGE PUMP	12 AMPS
3 - AUX BILGE PUMP	12 AMPS
4 - BATTERY SWITCH/ACR CONTROL	10 AMPS
5 - 24 HR.	10 AMPS
6 - ACC1	5 AMPS
7 - ACC2	5 AMPS

• **The cabin fuse block** is located on the port wall of the electronics bay and can be accessed through a panel behind the port cabin lounge.

1 - SUMP PUMP	4 AMPS
2 - VACUUM PUMP	10 AMPS
3 - CABIN OUTLET	15 AMPS
4 - AC/DC PANEL BACKLIGHT	5 AMPS
5 - TV	10 AMPS
6 - DISCHARGE PUMP	20 AMPS

• Cabin 24 hour fuse block

1 - CO MONITOR	5 AMPS
2 - KEY FOB POWER	5 AMPS
3 - STNG POWER	3 AMPS
4 - SPARE	

• **The console fuse block** is located in the base of the console and can be accessed through a panel on the aft wall of the head.

1 - A/C BLOWER	7 AMPS
2 - PHOTO CELL POWER	5 AMPS
3 - FIRE EXTINGUISHER INDICATOR	5 AMPS
4 - FLIR VIDEO	5 AMPS

• Console Breaker block

1 - DEFROSTER	15 AMPS
2 - HELM SEAT	10 AMPS
3 - SPOTLIGHT	10 AMPS
4 - VENT	10 AMPS

- 5 - WINDLASS CONTROL 10 AMPS
- 6 - ACC

• **The electronics fuse block** is located on the port wall of the forward bilge opposite the batteries and can be accessed through the base of the forward cabin lounge.

- 1 - MFD 1 POWER 15 AMPS
- 2 - MFD 2 POWER 15 AMPS
- 3 - RADAR 20 AMPS
- 4 - VHF 10 AMPS
- 5 - CONSOLE NETWORK SWITCH 3 AMPS
- 6 - NETWORK SW 3 AMPS
- 7 - FISH FINDER 5 AMPS
- 8 - FISH FINDER 5 AMPS
- 9 - AUTOPILOT 5 AMPS
- 10 - SAT WEATHER 20 AMPS
- 11 - FLIR CAMERA 5 AMPS
- 12 - ACC

In the event you need to replace a fuse, use only the same amperage as the original. It is recommended that you carry spare fuses.

If a fuse is replaced with one of lower amperage, it will not be sufficient to carry the electrical load of the equipment it is connected to and will cause nuisance fuse failure or breaker tripping.

If a fuse is replaced with one of higher amperage, it will not provide adequate protection against an electrical malfunction and will create a fire hazard

Ground Fault Interrupter (GFI)

Your boat is equipped with three ground fault interrupter (GFI) receptacles. One is located on the aft wall of the head (see Figure 4.12.1), another on the starboard side of the prep station (see Figure 2.12.1) and a third on the forward face of the starboard cabinet in the cabin (see Figure 2.12.1). The GFI receptacle is designed to protect people from the line-to-ground shock hazards which could occur from defective tools or appliances operating from the receptacle, or from down-line outlets protected by it.

The GFI will not prevent line-to-ground electric shock, but does limit the time of exposure to a period considered safe for normal healthy persons.

The receptacle will not protect against line-to-line or line-to-neutral faults, short circuits or overloads.

⚠ WARNING

Persons with heart problems or other conditions which may make them susceptible to electric shock may still be injured by ground faults on circuits protected by the GFI receptacle. No safety devices yet designed will protect against all hazards or carelessly handled or misused electrical equipment or wiring.

Testing

The GFI outlet has a TEST and RESET button that you can use to regularly test the outlet for proper operation. Before testing the outlet, push the RESET button in. Plug an appliance into the outlet (such as a lamp) and turn it on. Push the TEST button, the appliance should shut OFF. If it does, the circuit was interrupted and it is working properly. Push the RESET button to return the power to the outlet. If the power to the appliance was not interrupted, have a qualified marine electrician check the system to find the problem.

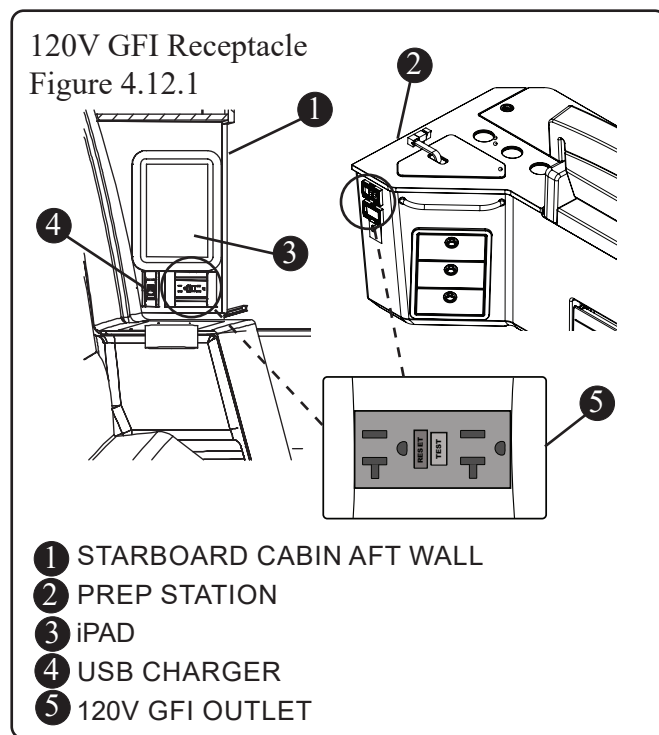
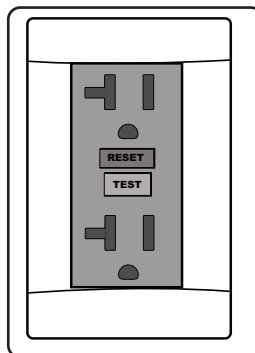

Digital Switching

This vessel's digital switching system replaces traditional mechanical switches and circuit breakers with digital power distribution modules to provide monitoring and control of the electrical system. These modules are controlled from the helm displays, iPad, wireless remote, or switch panels. CZone, Raymarine, and EmpirBus modules are located behind seat panels in the cabin. For the convenience of the operator, some switch functions duplicate those of mechanical switches.

CZone™ Wireless Remote

The CZone wireless remote control key fob (see Figure 4.13.1) allows operation of four different functions from a distance of up to 250 feet (80 meters).

CZone Wireless Remote Key Fob

(FIGURE 4.13.1)

- 1 HOUSE BATTERY SWITCH ON*
- 2 HARDTOP OVERHEAD LIGHTS ON/OFF
- 3 CABIN OVERHEAD LIGHTS ON/OFF
- 4 DECK COURTESY LIGHTS ON/OFF

*Switch does not turn house battery off.

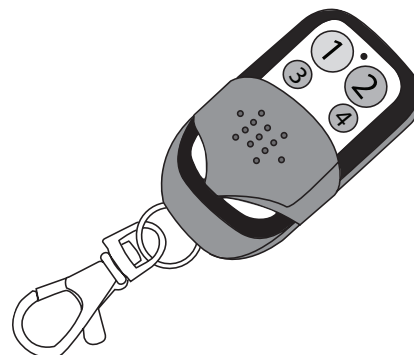

Digital Switching Display

Tap on the *SWITCH PANEL* icon (see Figure 4.13.2) on the helm display and tap arrows to access additional functions that control and monitor various systems.

⚠ CAUTION

To maintain digital switching access, do not update software on Raymarine navigation system, VesselView or iPad without first contacting a Boston Whaler dealer.

Switch Panel
Figure 4.13.2

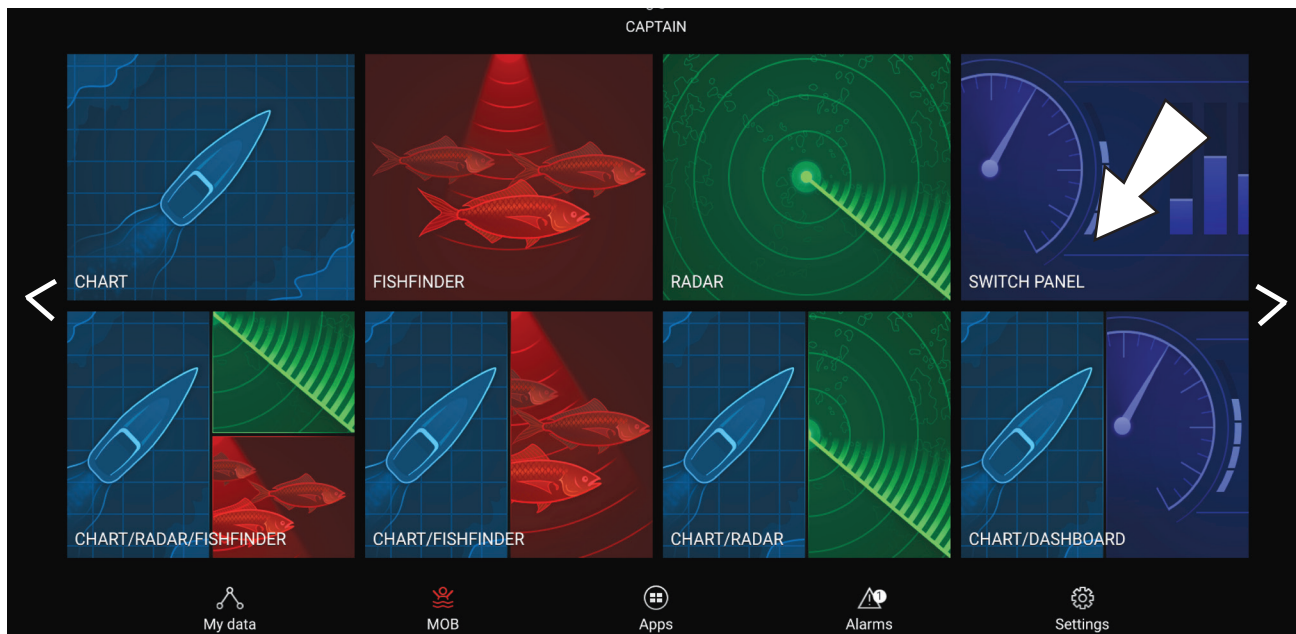

Digital Switching Tabs

There are six digital switching system tabs including gauges, lights, RGB (lighting colors), controls, systems, and alarms (see Figure 4.14.1). Switches glow with a blue ring when selected.

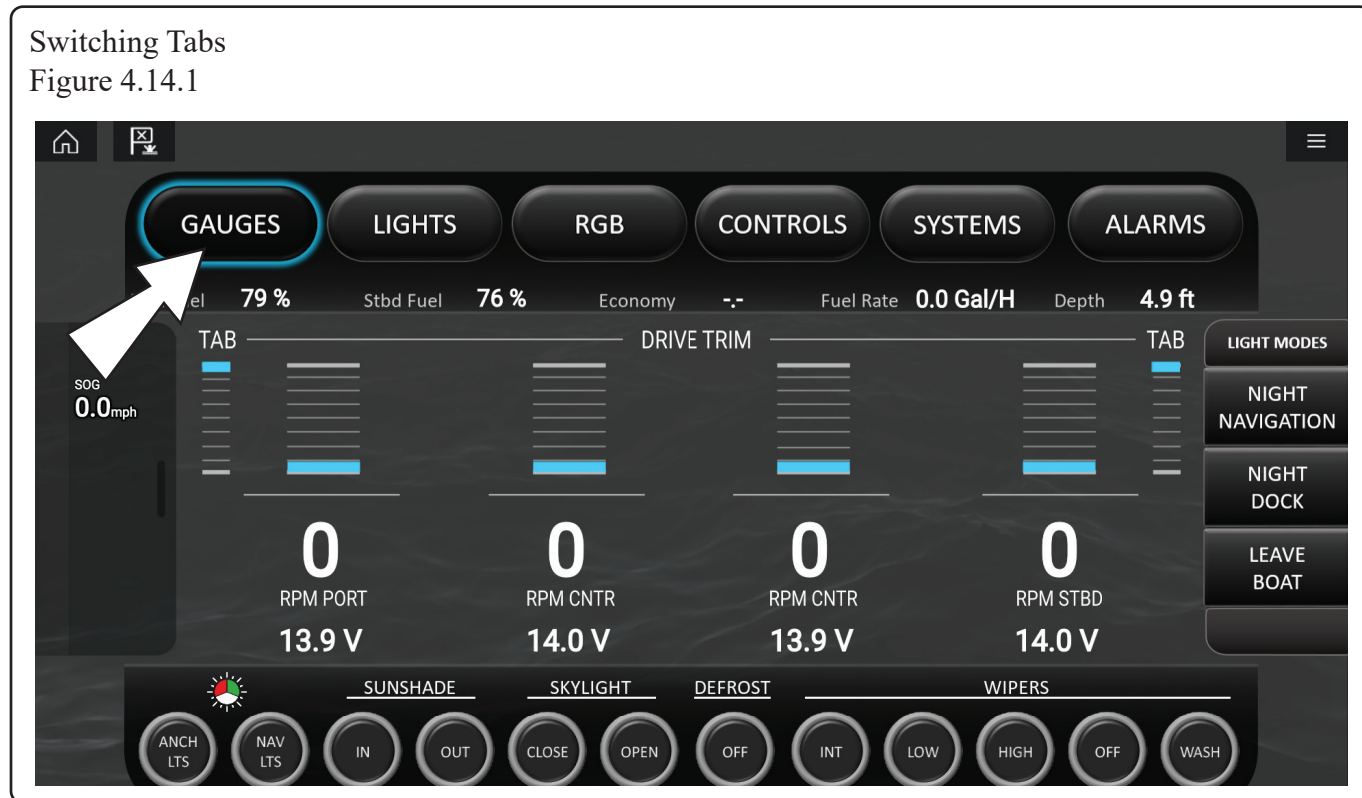

iPad

This vessel is equipped with an iPad in the cabin that is charged by placing it against the magnetic charging base station. Once the iPad attached to the base, charging starts immediately.

Connecting iPad to Boat's Wi-Fi Interface

Contact your Boston Whaler dealer for information on connecting the boat's iPad to the onboard Wi-Fi interface (EmpirBus module). This pairing allows control and monitoring of certain systems via the iPad.

Digital Switching on the iPad

There are five digital switching system tabs including gauges, lights, RGB (lighting colors), controls, systems, and alarms. Switches glow with a blue ring when selected.

CAUTION

To maintain access to digital switching, do not update software, especially OS versions on either the Raymarine navigation system, VesselView unit or the iPad without contacting a Boston Whaler dealer.

CZone Wi-Fi Interface Module

Figure 4.14.1

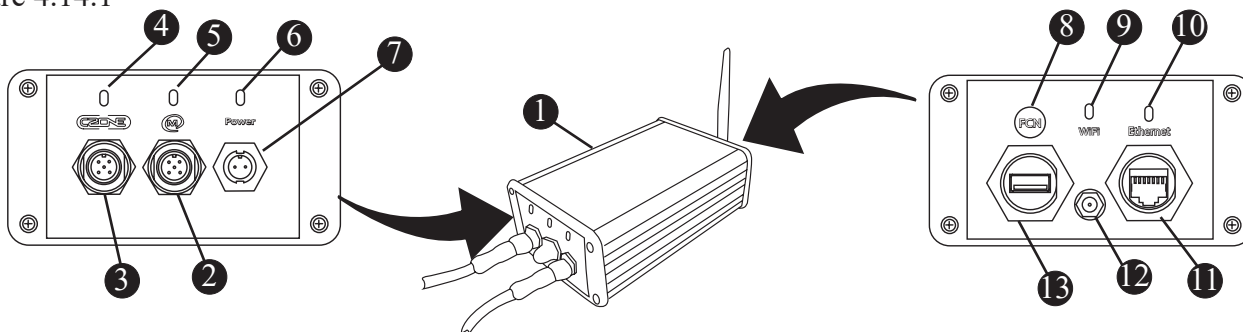

- | | |
|---|---|
| <ul style="list-style-type: none"> ❶ CZONE Wi-Fi INTERFACE MODULE ❷ NMEA 2K - MASTER BUS ❸ NMEA 2K - CZONE ❹ CZONE DATA/POWER LED ❺ MASTER BUS DATA/POWER LED ❻ POWER LED ❼ DC INPUT | <ul style="list-style-type: none"> ❽ FUNCTION BUTTON ❾ LED ❿ LED ETHERNET ⓫ ETHERNET SOCKET ⓬ WI-FI AERIAL ⓭ USB SOCKET |
|---|---|

LED FUNCTION

LED	LED State	LED Meaning
Power LED	Green	Power ON
CZone and MasterBus Data/Power LED	Green	Connected
CZone and MasterBus Data/Power LED	Red Flash	Traffic

LED Mode	WiFi LED State	Ethernet LED State	Meaning
OFF	—	—	Not active or connected
ON continuously	Enabled	Connected	Normal use

REFER TO THE MANUFACTURER'S MANUAL IN YOUR OWNER'S MANUAL PACKET FOR COMPLETE INSTRUCTIONS AND WARRANTY.

Transducer

Transducer Location
Figure 4.17.1

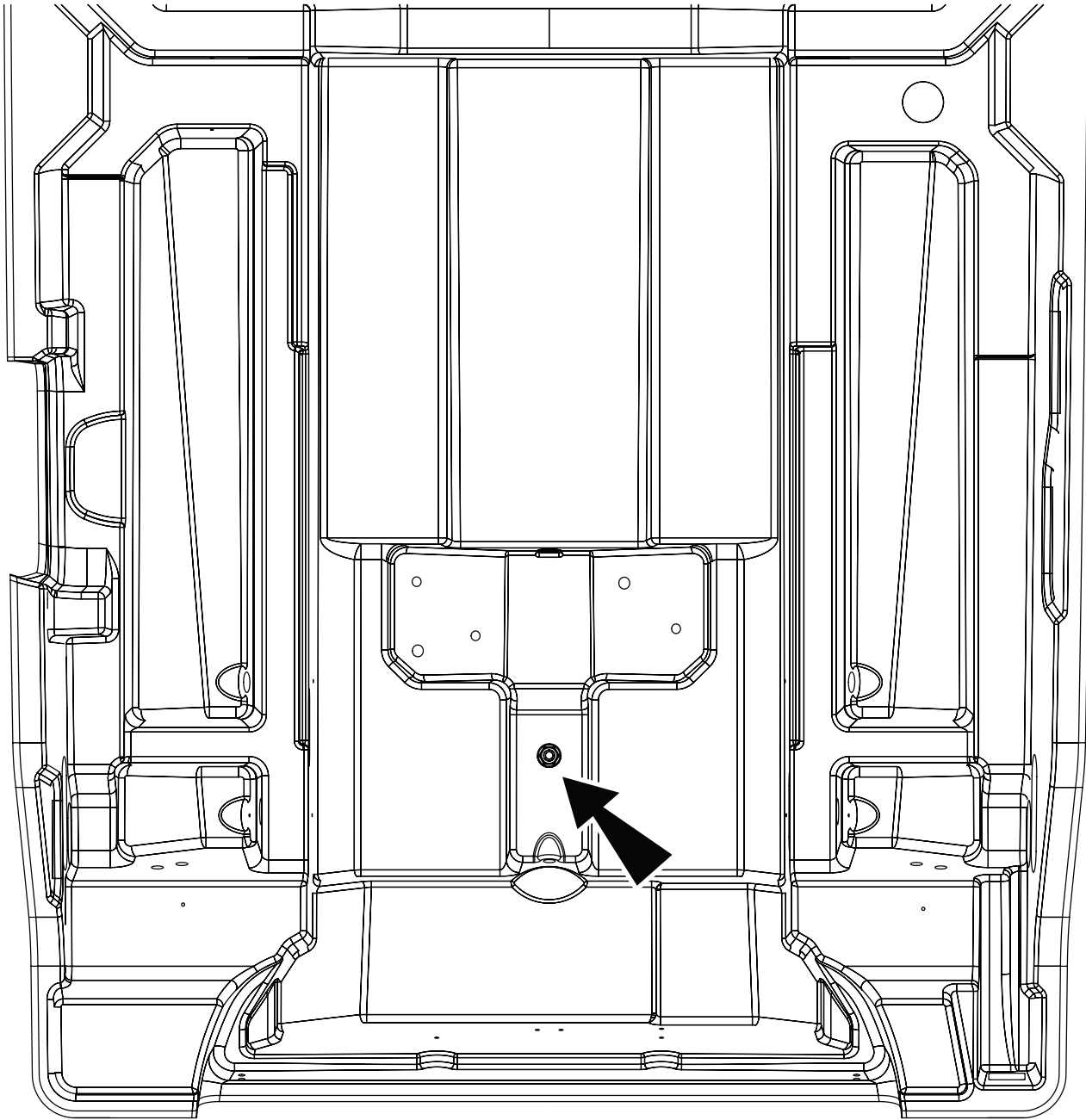

Chapter 4 • Electrical System

Electrical Schematics and Harnesses

The following pages contain schematics and harnesses pertaining to the electrical system in your boat. These schematics were generated by electrical engineers in the Boston Whaler® Engineering Department and are for reference and to be used by service technicians.

Boston Whaler® does not recommend that you attempt to work on the electrical system yourself. Instead, we suggest that you take your boat to an authorized Boston Whaler® dealer for electrical service.

Boston Whaler® reserves the right to change or update the electrical system on any model at any time without notice to the customer and is not obligated to make any updates to units built prior to the change.

Wiring Identification Chart

Boston Whaler® adheres to electrical wiring requirements which meet all the ABYC-E11 standards. The following chart outlines the gauge, color and function of the wiring used.

Wire Color Chart for DC and Special Circuit

COLOR	FUNCTION	COLOR	FUNCTION
GRN	GROUNDING MAIN/TOWER & ALUMINUM FUEL TANKS	BRN/ORN	SUMP PUMP
GRN	GROUNDING	BRN/RED	BILGE PUMP (UNSWITCHED)
ORN	STARBOARD 30 AMP RECEPTACLE	BRN/VIO	FORWARD FISHBOX PUMP
RED	MAIN FEEDS/PORT 30 AMP RECEPTACLE	BRN/WHT	MACERATOR
BRN/BLK	STARBOARD FISHBOX PUMP	BRN/YEL	LIVWELL PUMP
BRN/VIO	FORWARD FISHBOX PUMP	GRY	RUNNING LIGHTS
BRN/YEL	LIVWELL PUMP (HIGH CURRENT)	GRY/BLK	ACC 1
BRN/BLU	PORT FISHBOX PUMP	GRY/BLU	ACC 2
BLK	GROUND	GRY/GRN	ACC 3
RED	+12V MAIN	GRY/RED	AFT MAST/ACC 4
BLK	GROUND	GRY/WHT	ALL ROUND/FWD MAST LIGHT
BLK/YEL	STOP CIRCUIT	GRN	GROUNDING
BLK/WHT	GEN SHUTDOWN	ORN	REFRIGERATOR or CENTER WIPER
BLU	COMPASS	ORN/BLU	HORN
BLU/BLK	DOME LIGHT	ORN/BRN	STARBOARD WIPER PARK
BLU/GRN	SPREADER LIGHT	ORN/GRN	STARBOARD WIPER
BLU/ORN	LIVWELL LIGHT	ORN/RED	PORT WIPER
BLU/RED	COURTESY LIGHTS	ORN/VIO	VACUUM PUMP
BLU/VIO	CABIN LIGHTS	ORN/WHT	CENTER WIPER
BRN	BILGE PUMP (SWITCHED)	PINK	FUEL SENDER
BRN/BLK	STARBOARD FISHBOX PUMP	RED	12V RECEPTACLE
BRN/BLU	PORT FISHBOX PUMP	VIO	IGNITION
BRN/GRY	RAW WATER	WHT	CO MONITOR/ELECTRIC TRIM TAB (SWITCHED)
BRN/GRN	FRESH WATER	YLW	BLOWER/STEREO MEMORY
		YLW/RED	START

120VAC Diagram
Figure 4.19.1

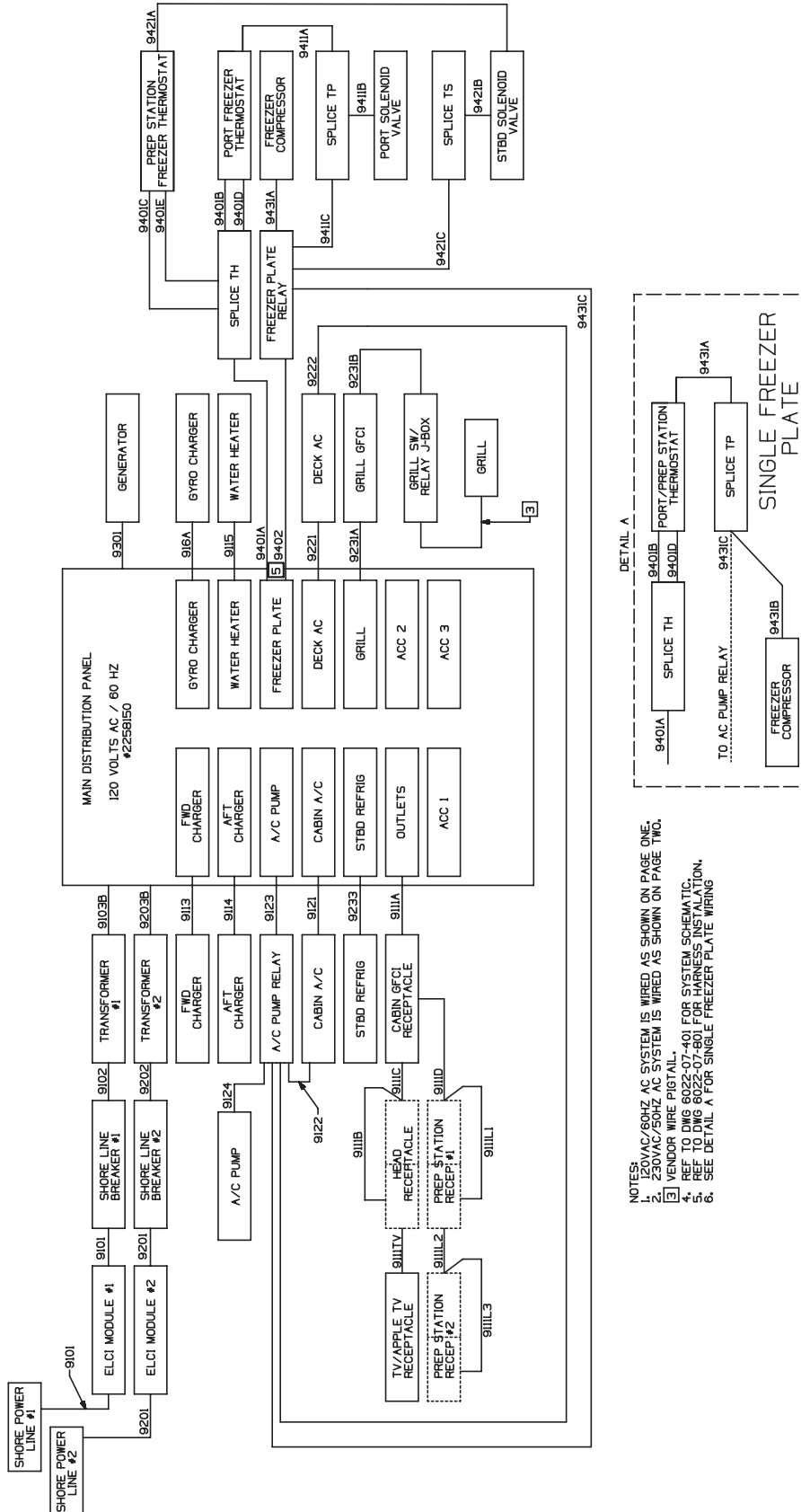

NOTES:
 1. 120VAC/60HZ AC SYSTEM IS WIRED AS SHOWN ON PAGE ONE.
 2. 230VAC/60HZ AC SYSTEM IS WIRED AS SHOWN ON PAGE TWO.
 3. VENDOR WIRE PIGTAIL
 4. REF TO DWG 8022-07-401 FOR SYSTEM SCHEMATIC.
 5. REF TO DWG 8022-07-801 FOR HARNESS INSTALLATION.
 6. SEE DETAIL A FOR SINGLE FREEZER PLATE WIRING

230VAC Diagram
Figure 4.20.1

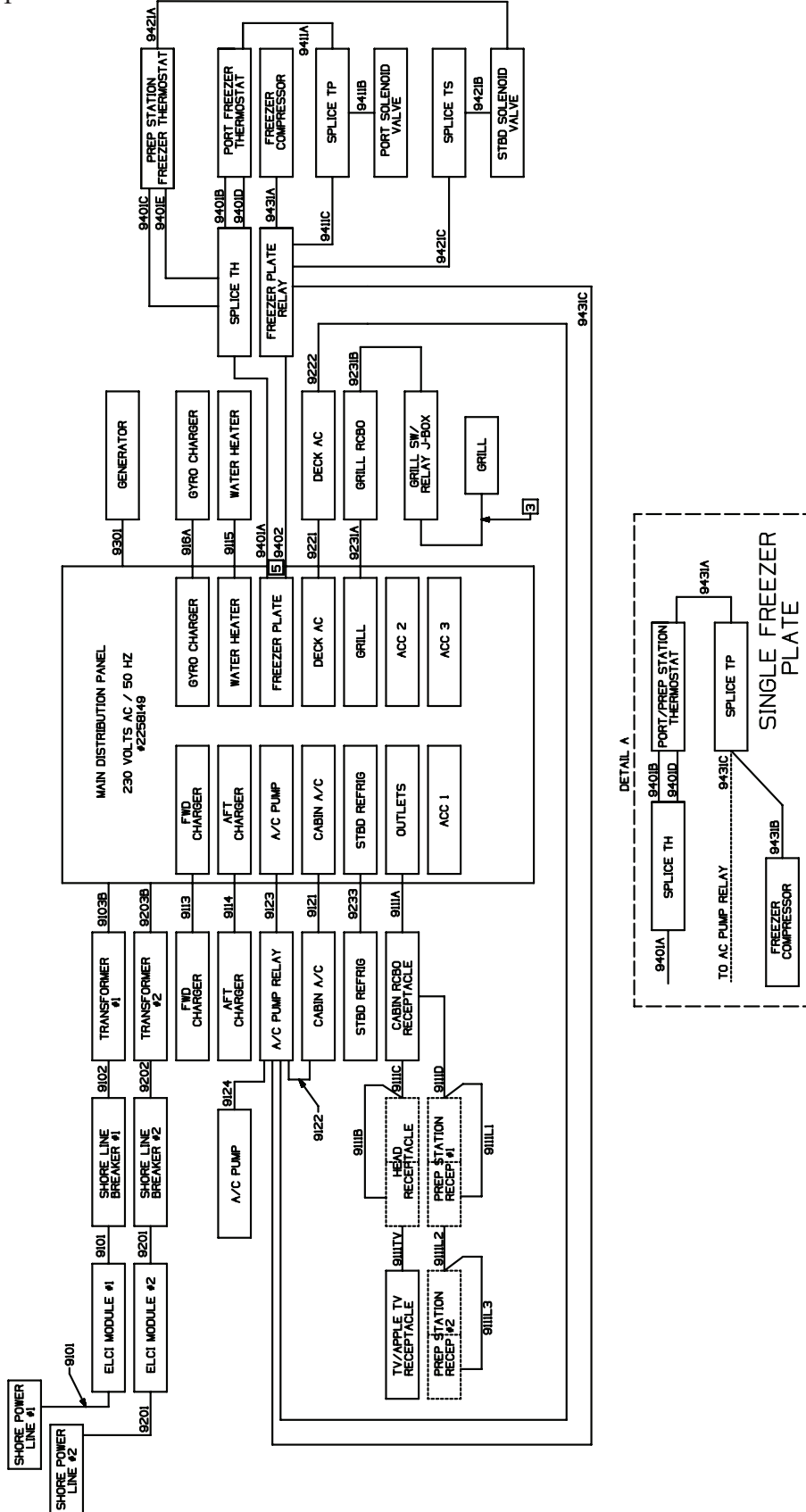

Switch/Receptacle Diagram - STANDARD
Figure 4.21.1

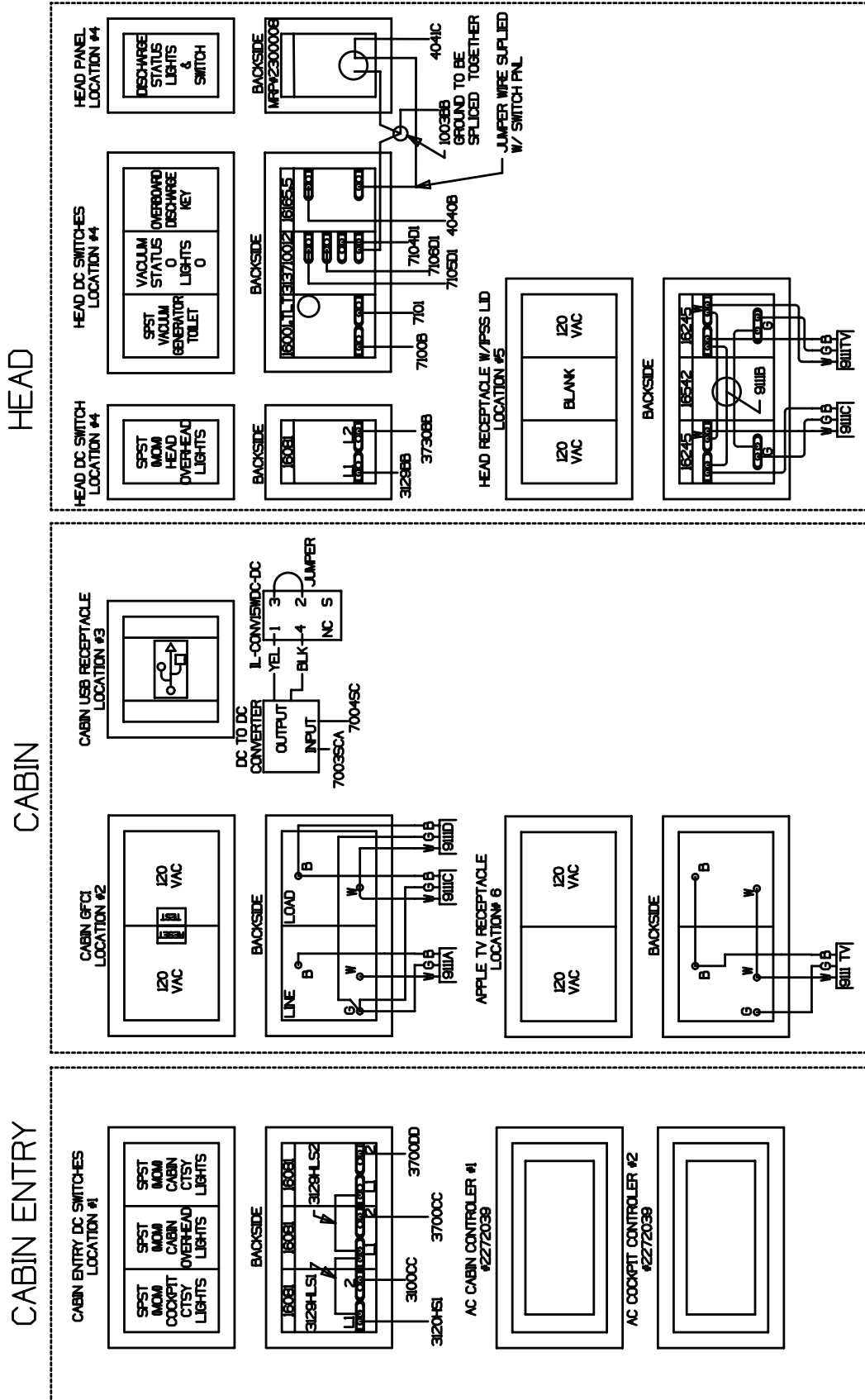

Switch/Receptacle Diagram - EURO
Figure 4.23.1

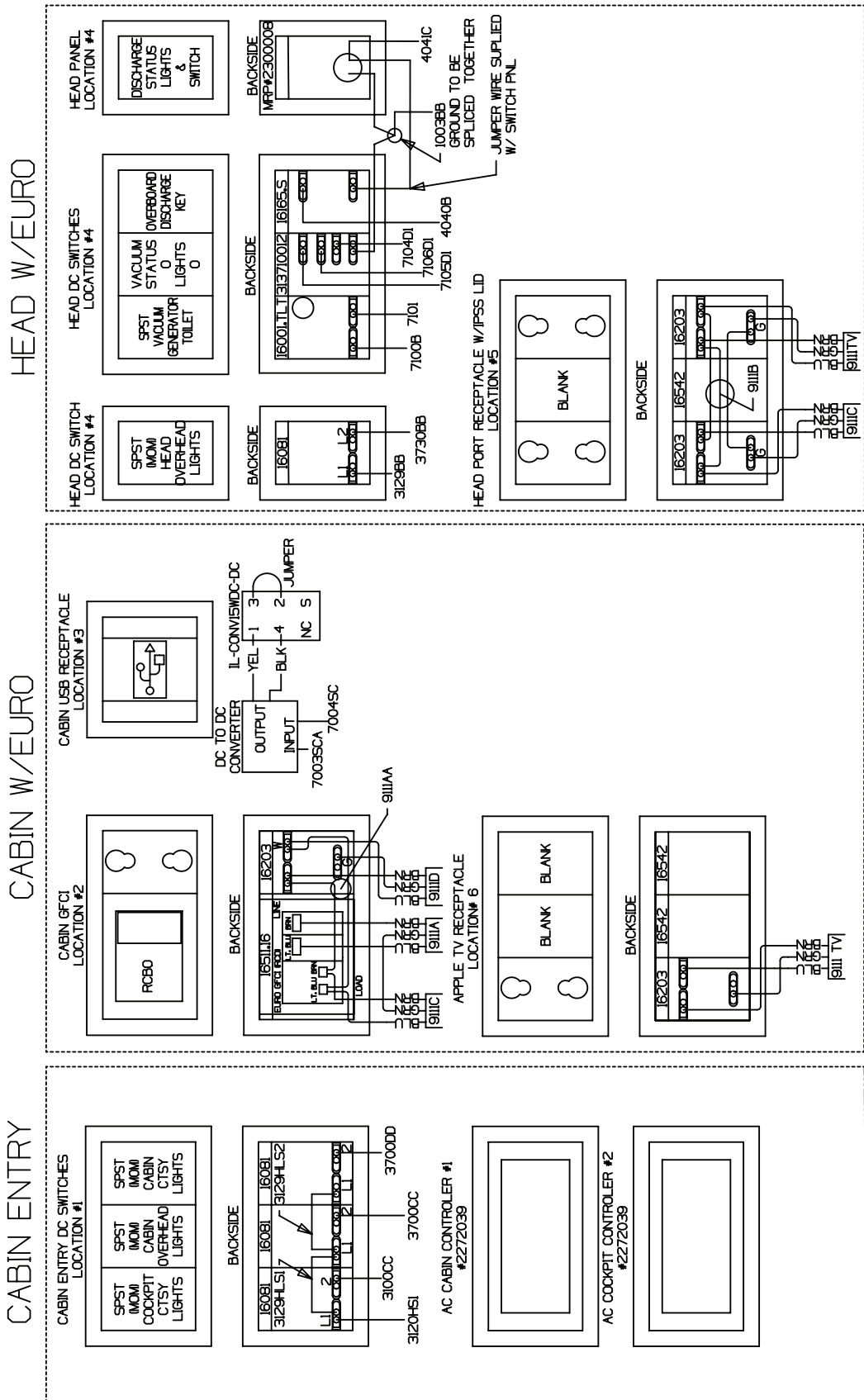

Switch/Receptacle Diagram - EURO
Figure 4.24.1

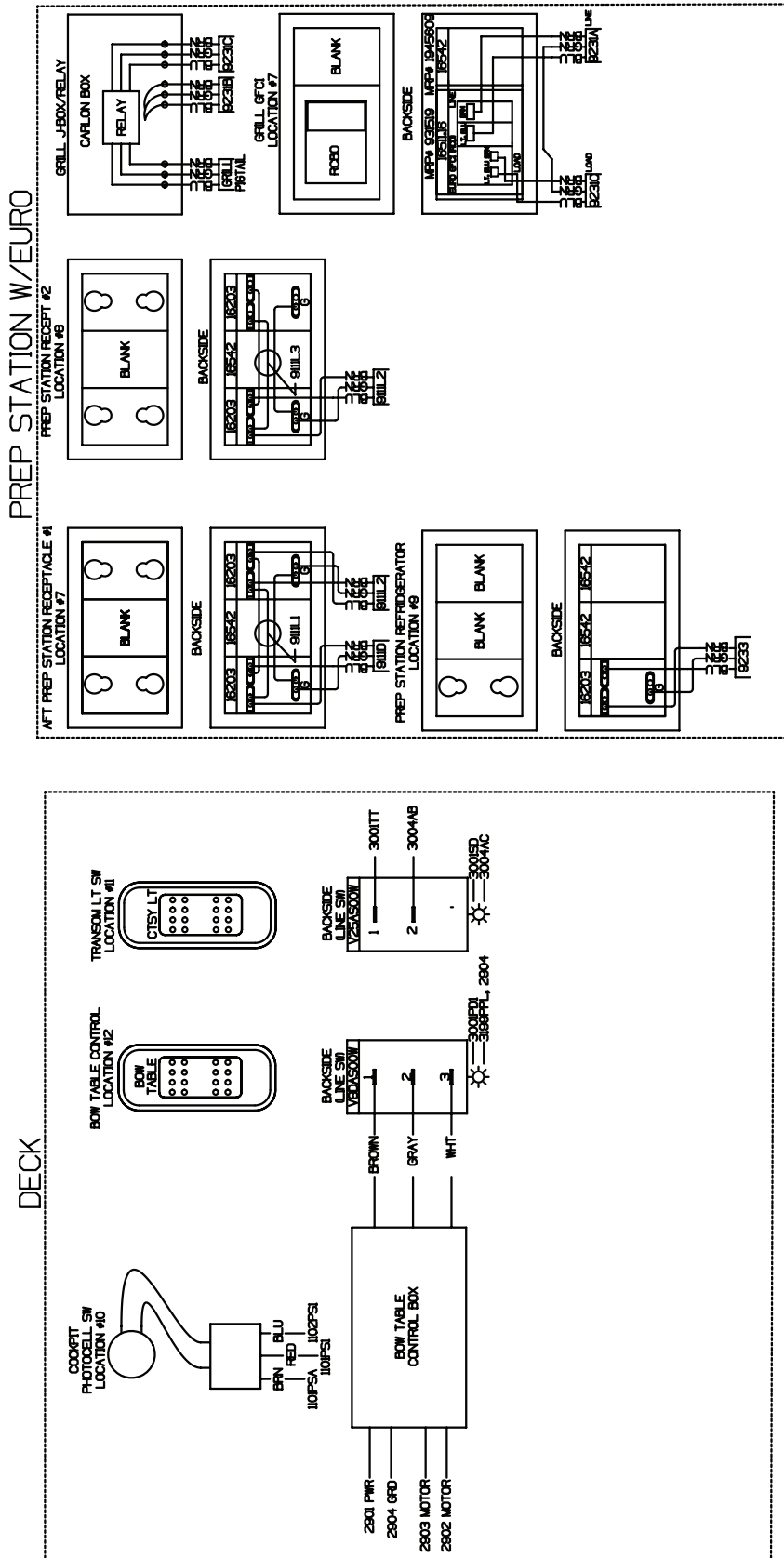

Batteries-Standard
Figure 4.25.1

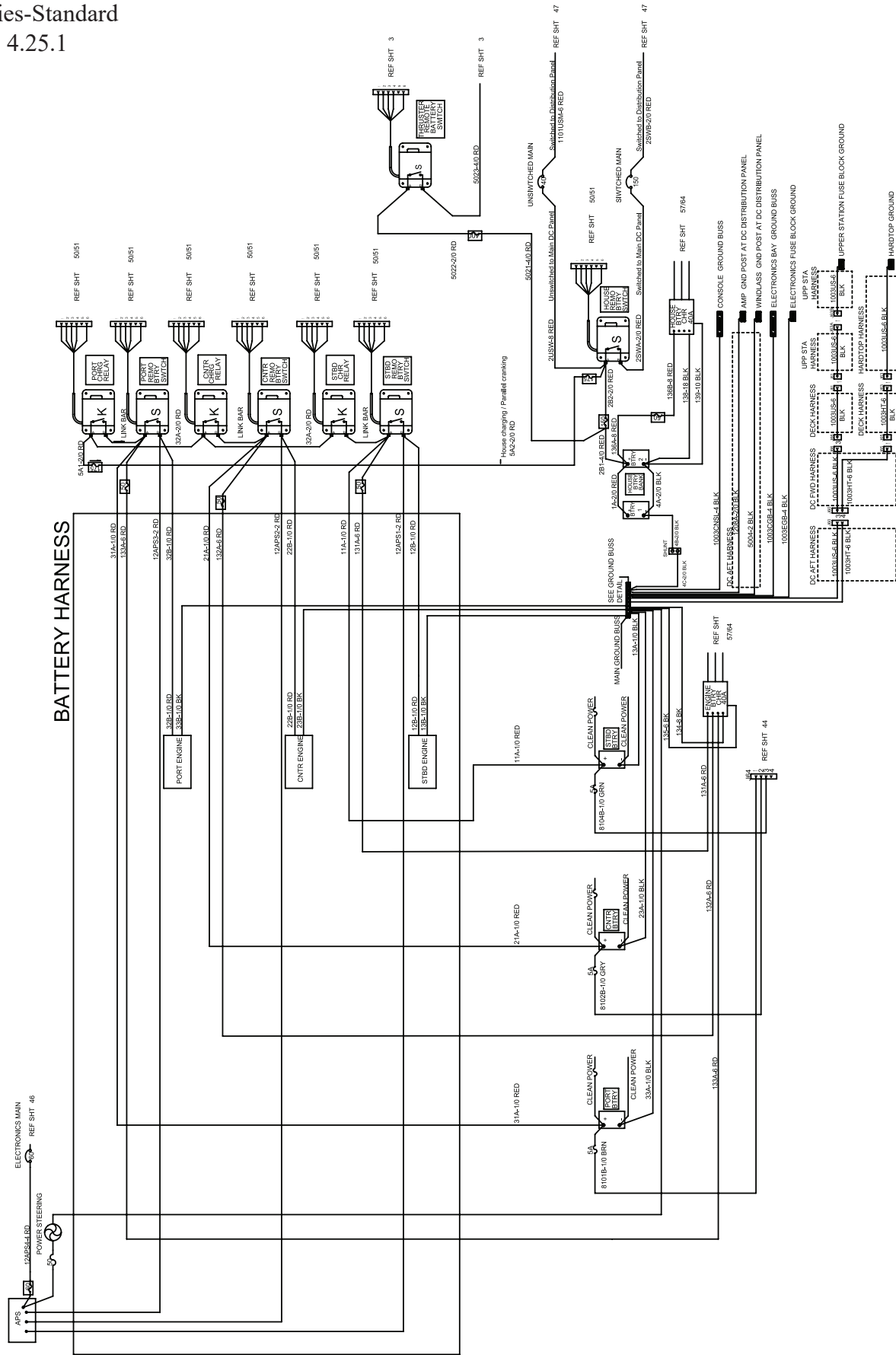

Batteries-JPO
Figure 4.26.1

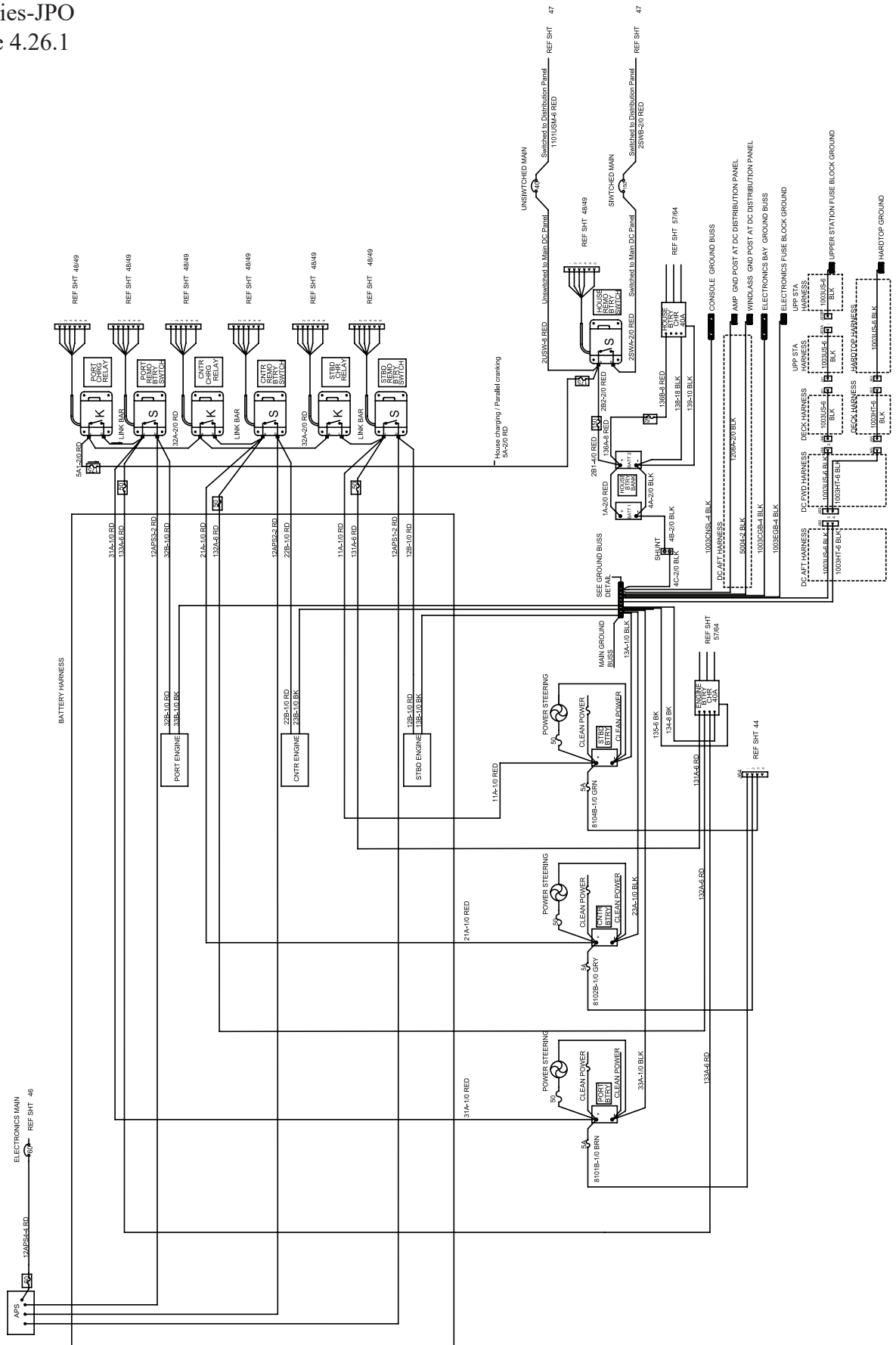

Bow Thruster
Figure 4.27.1

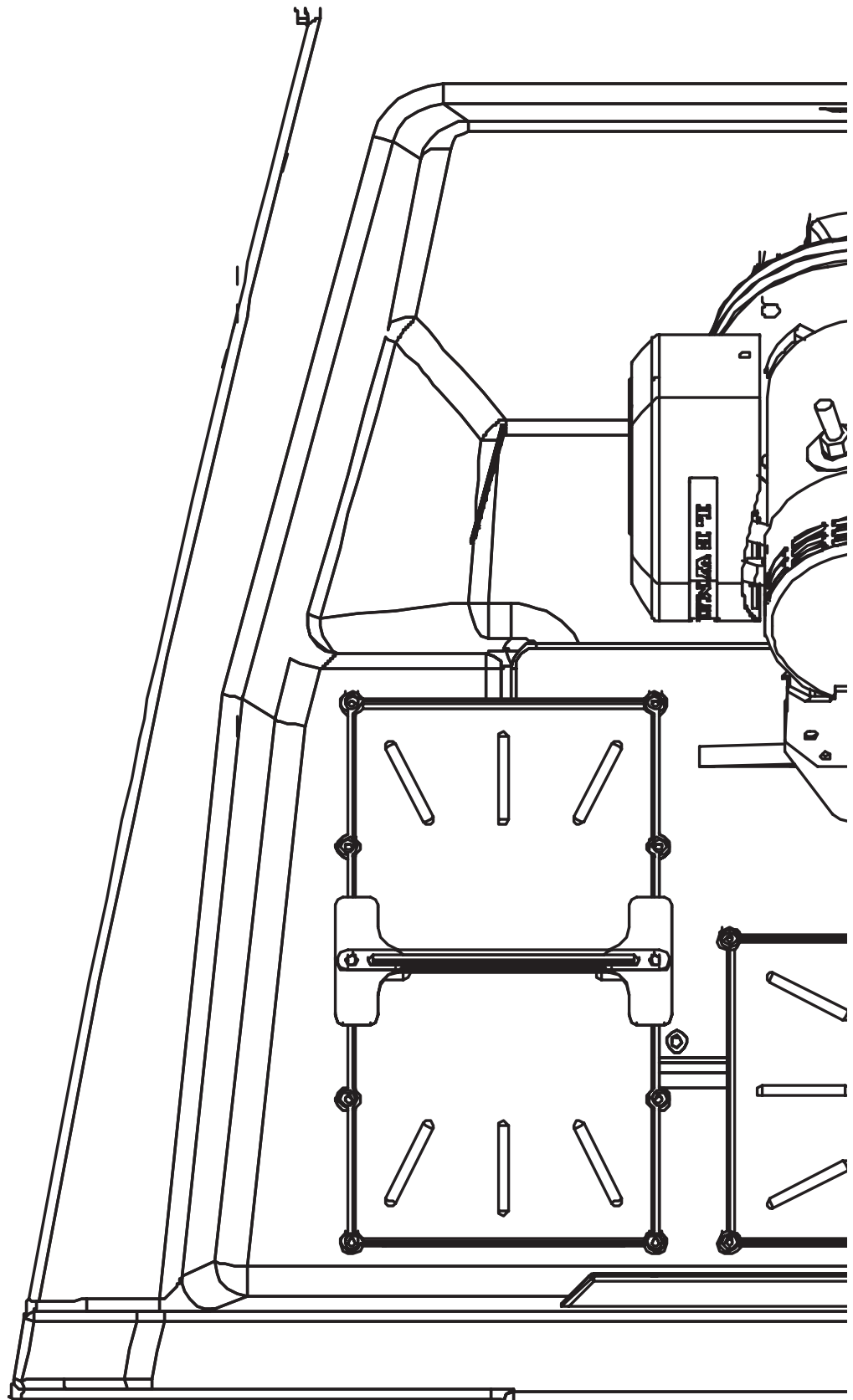

Gyroscopic Stabilizer DC and AC (Option)
Figure 4.28.1

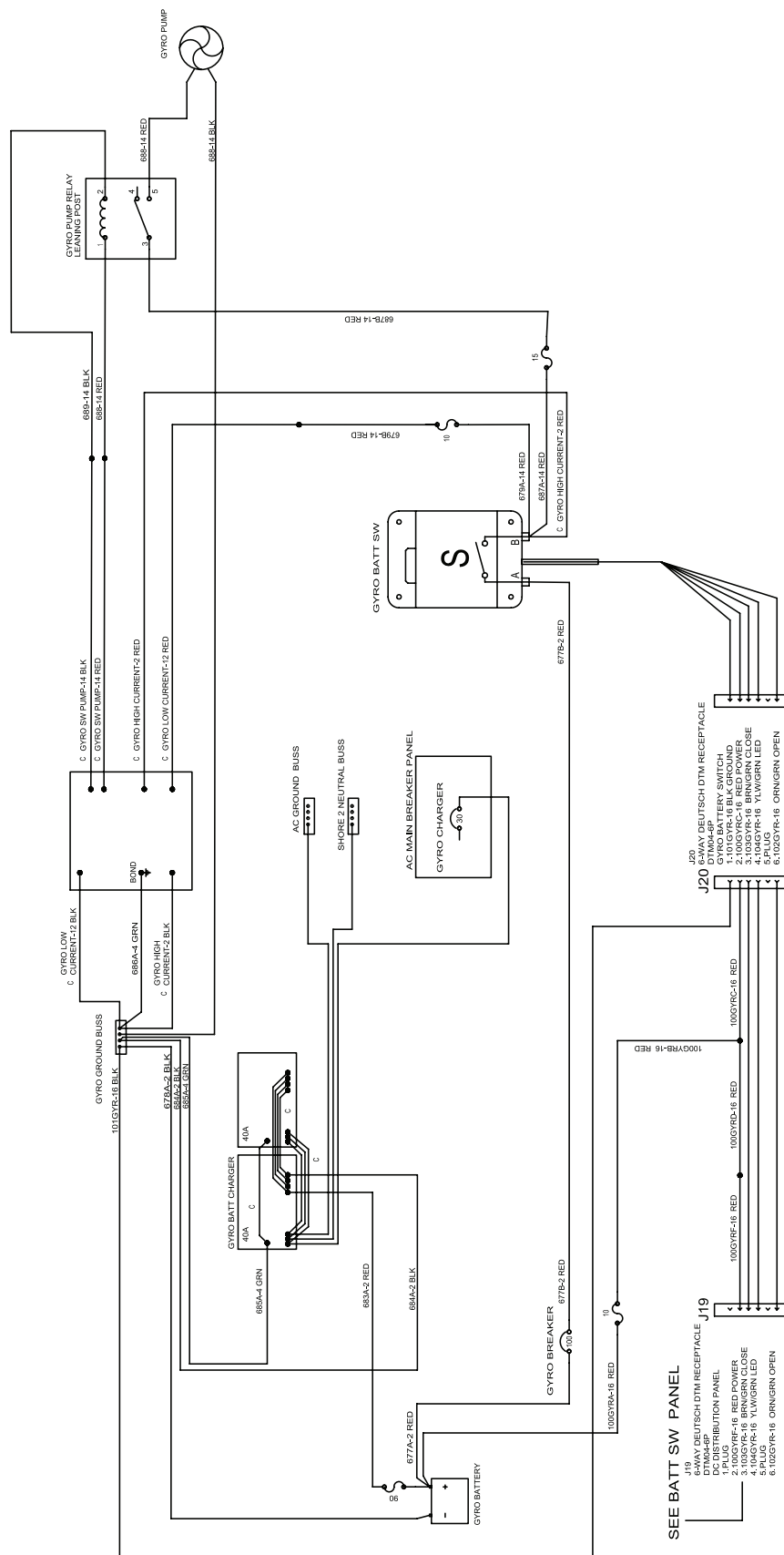

Bonding
Figure 4.29.1

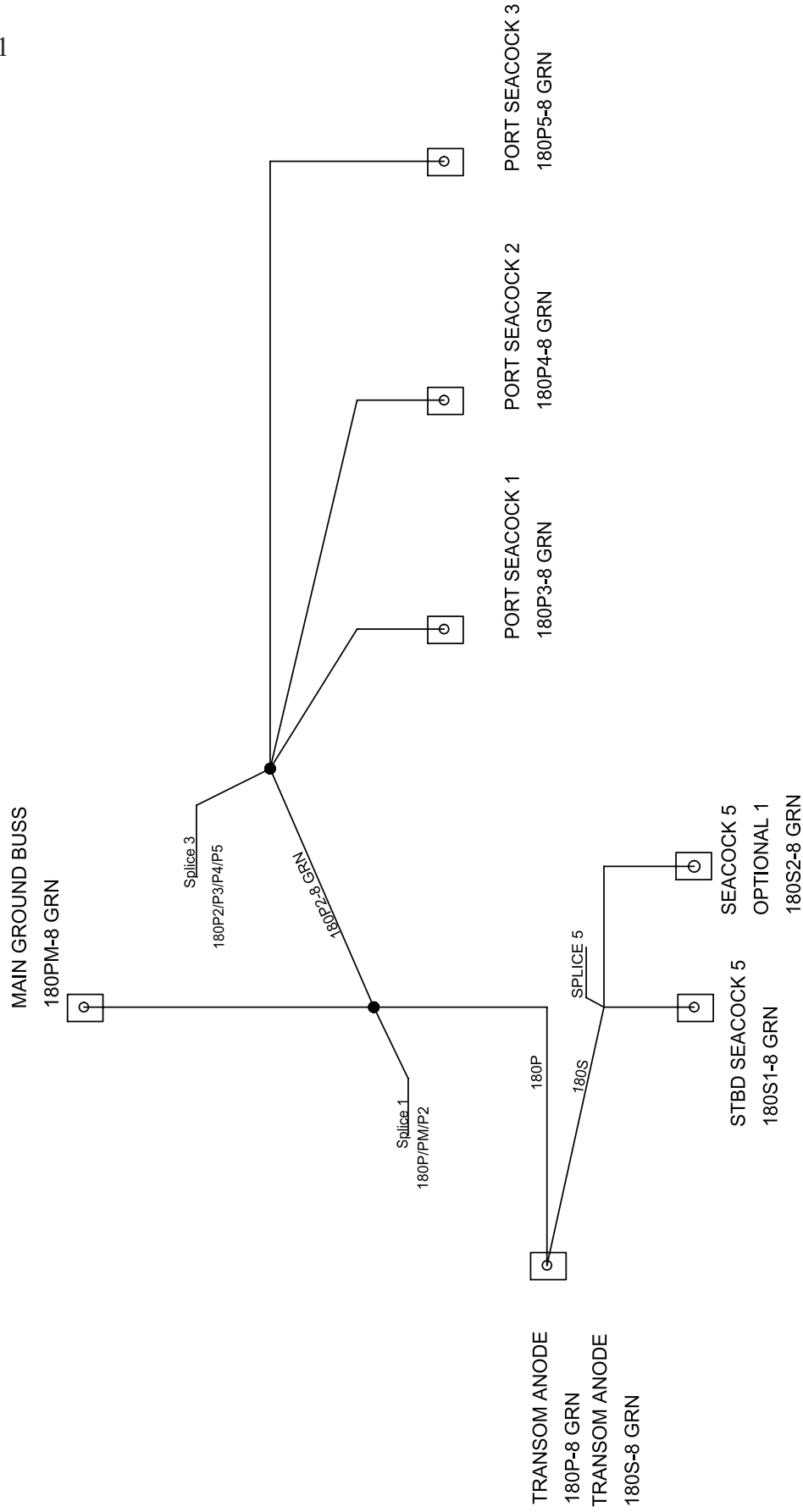

Bonding Gyroscopic Stabilizer (Option)
Figure 4.30.1

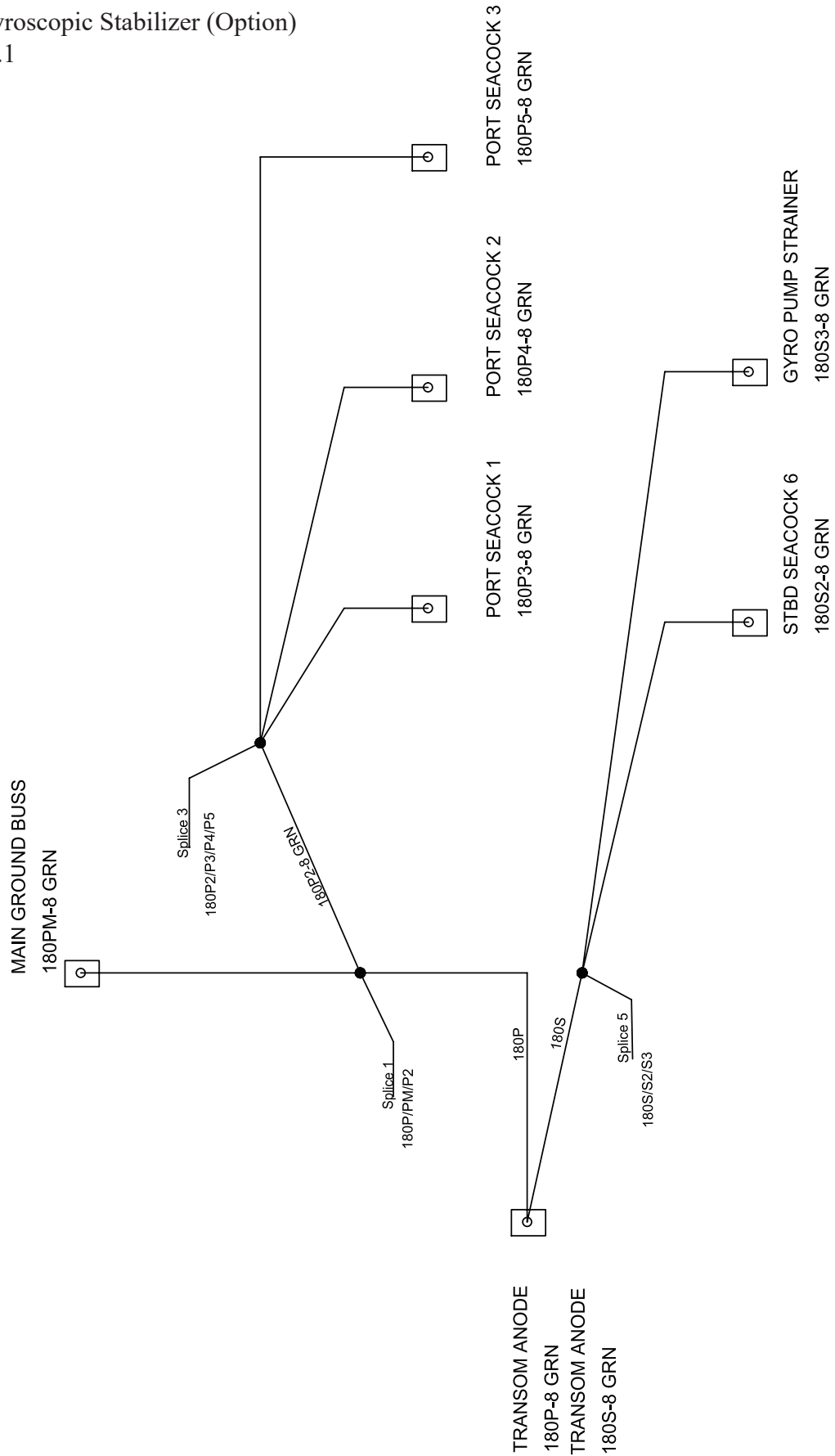

30A Receptacle
Figure 4.31.1

30A RECEPTACLE

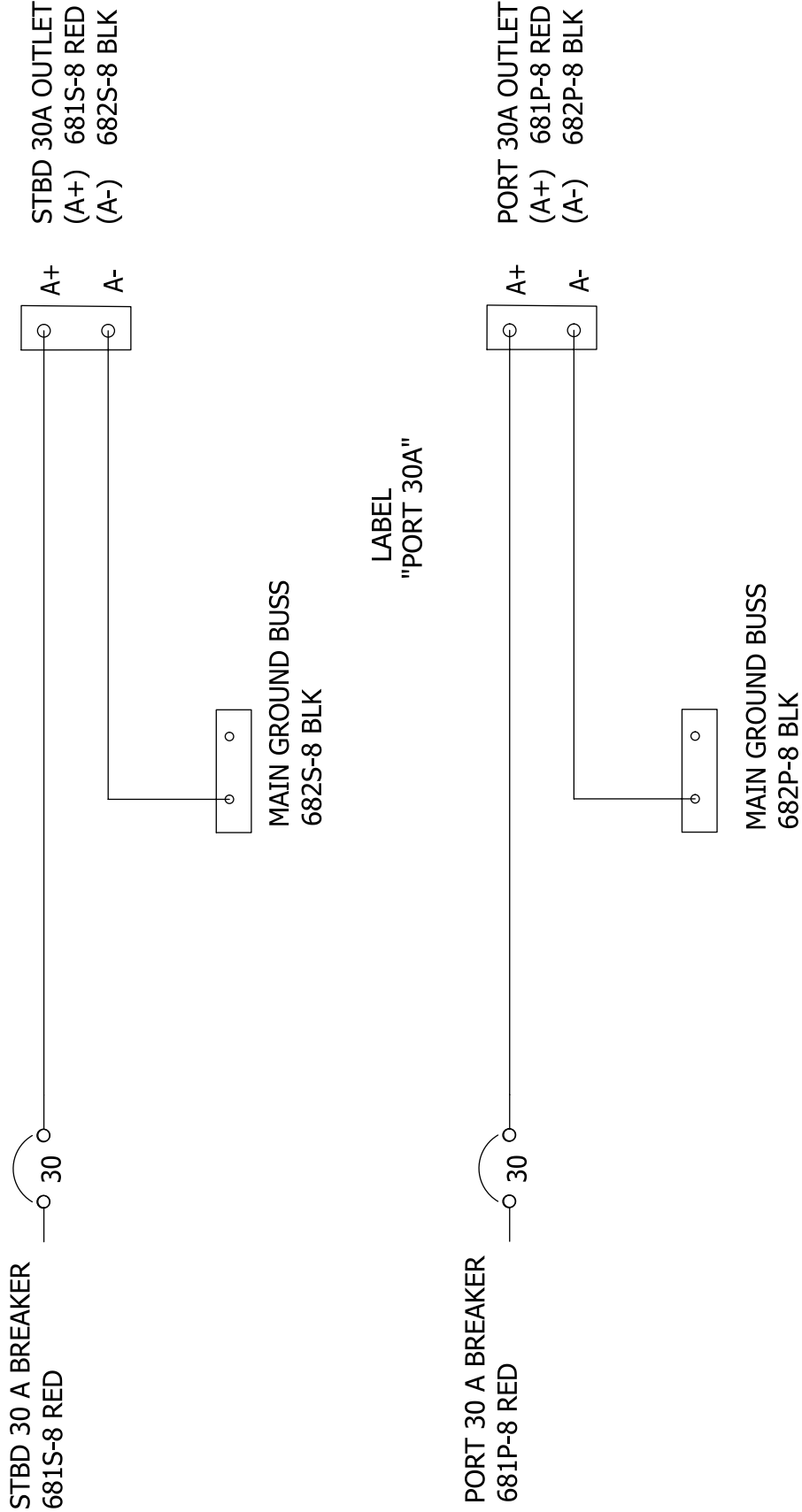

Horn Schematic
Figure 4.32.1

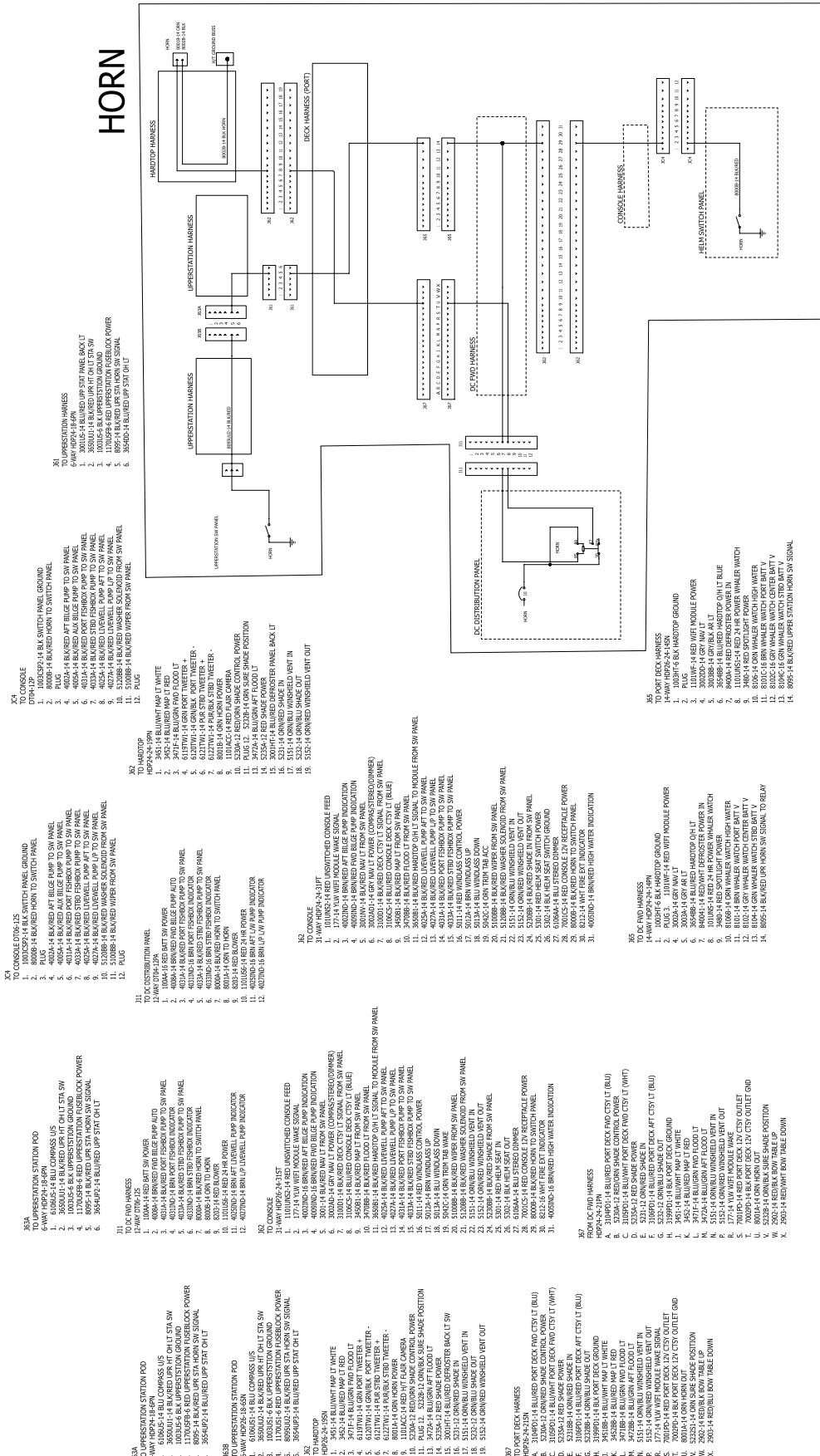

Wiper Schematic
Figure 4.35.1

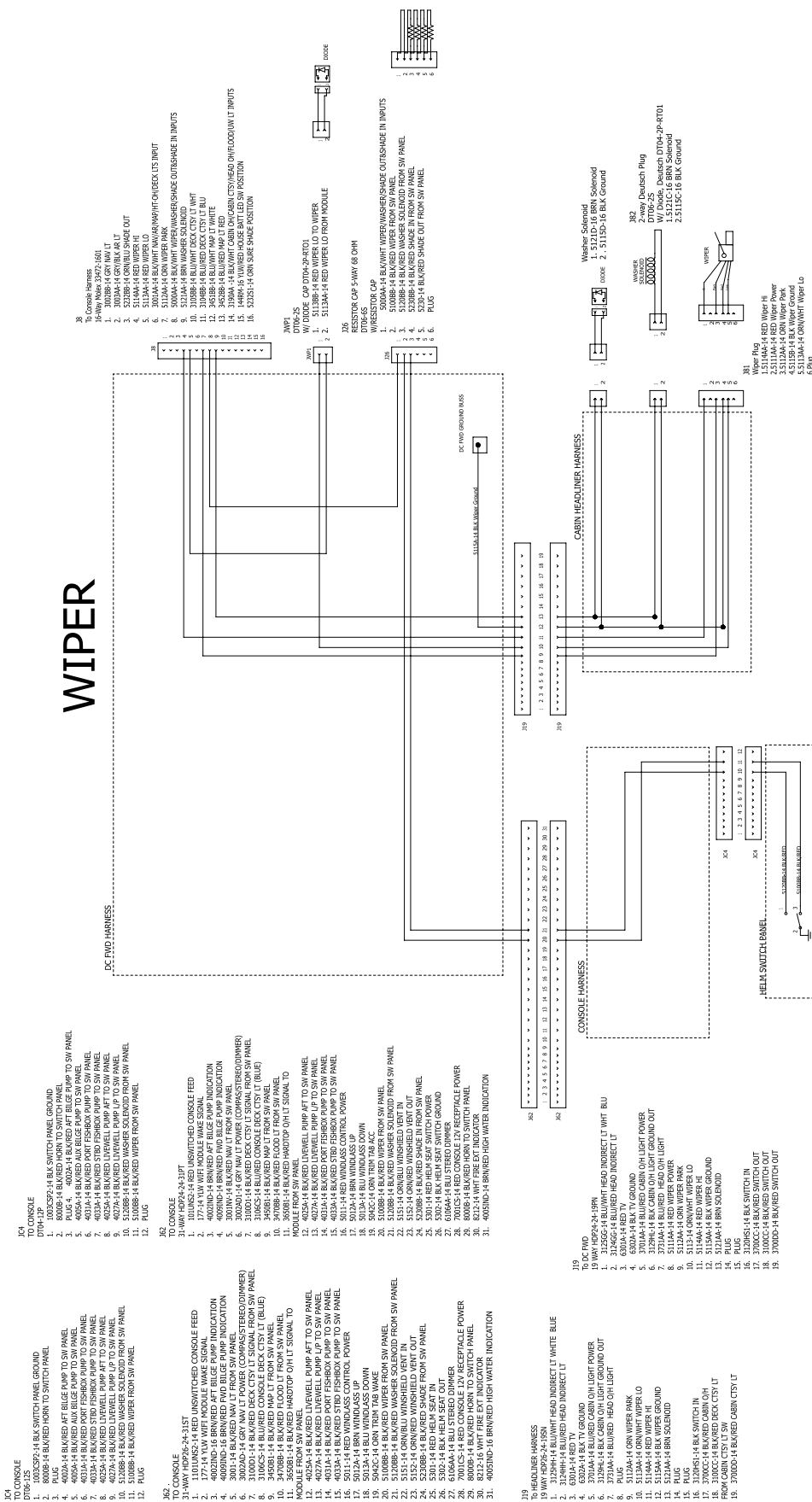

Vent Schematic
Figure 4.36.1

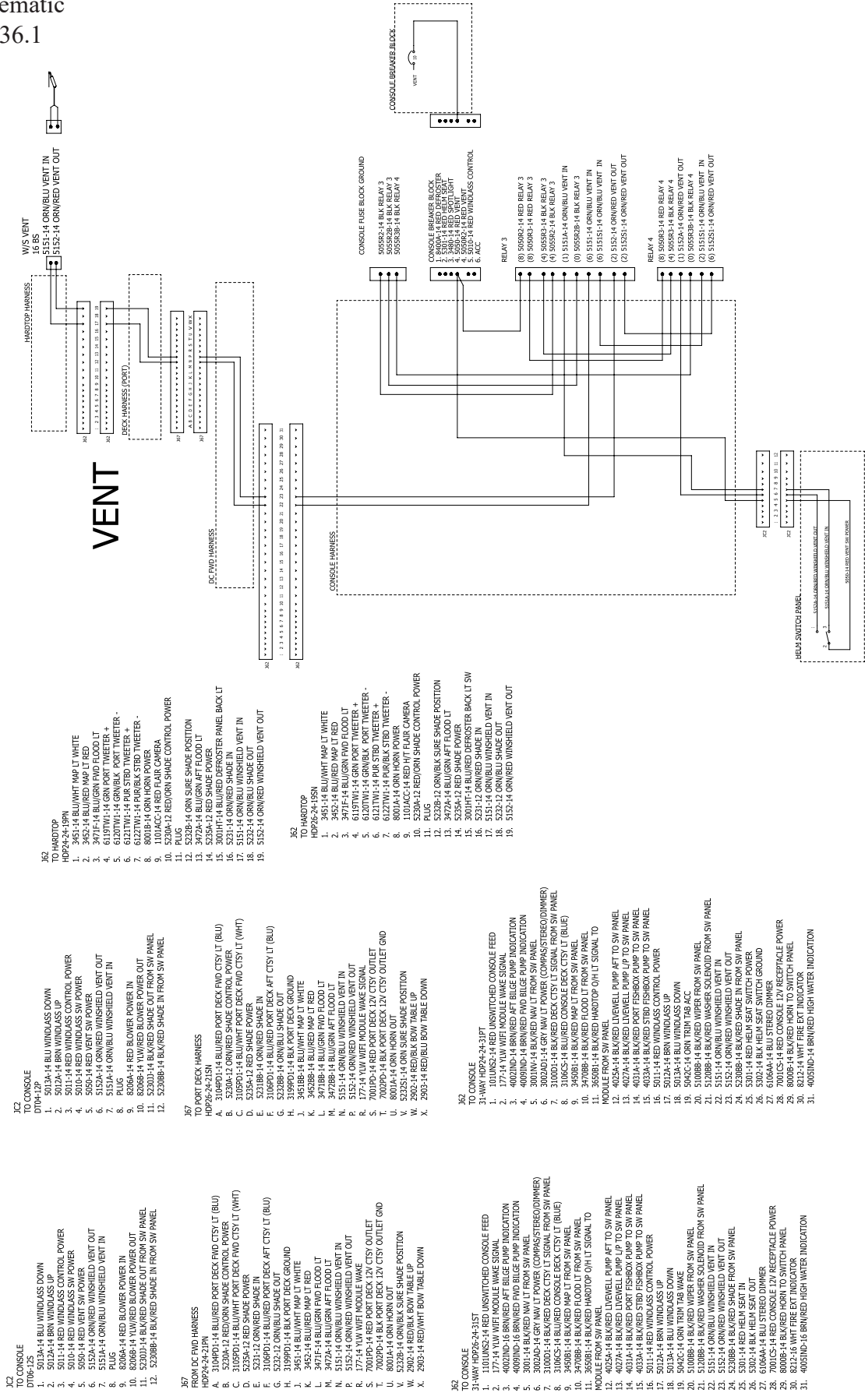

Trim Tabs Schematic
Figure 4.37.1

TRIM TABS

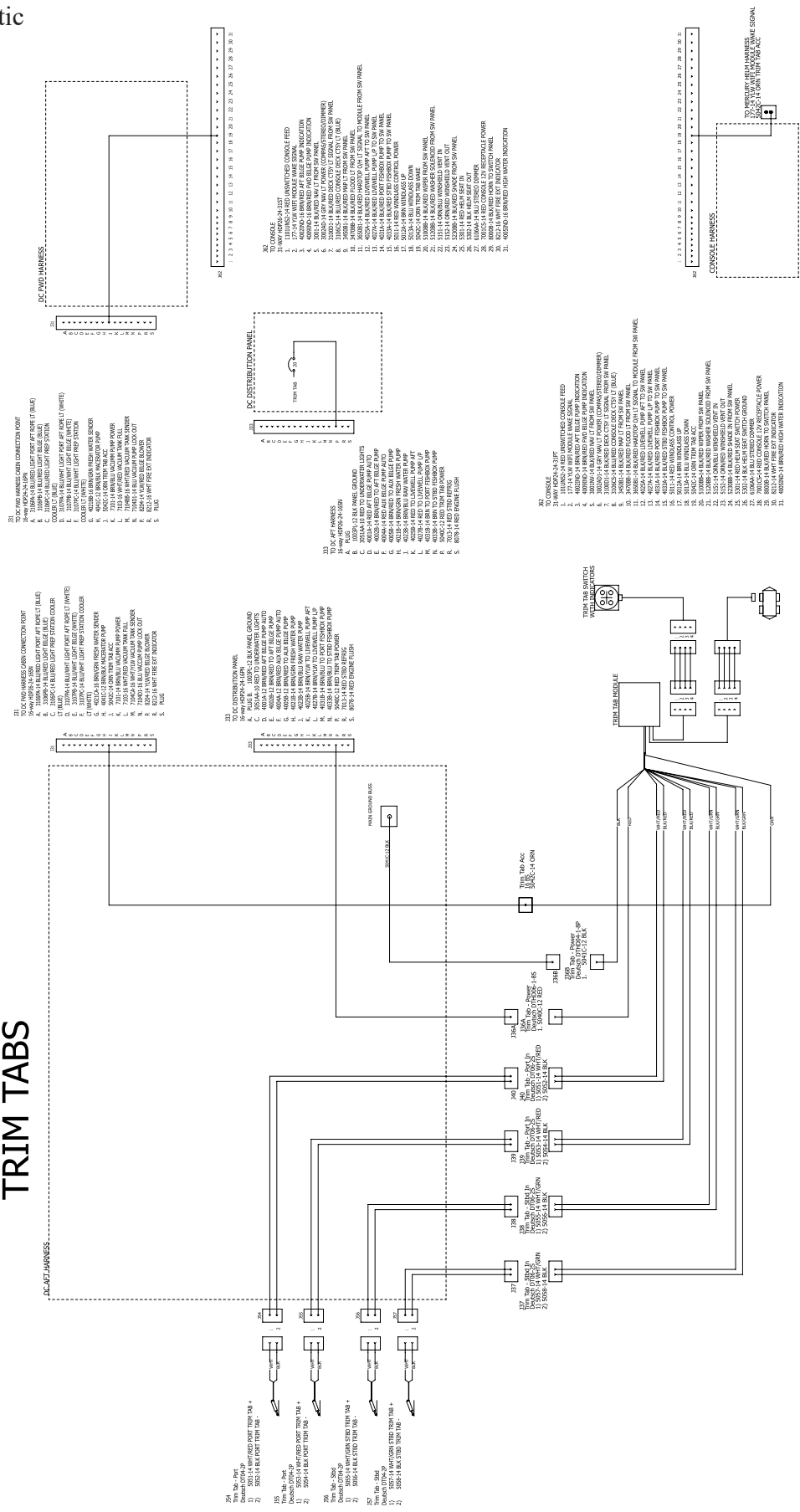

Engine Flush Schematic
Figure 4.38.1

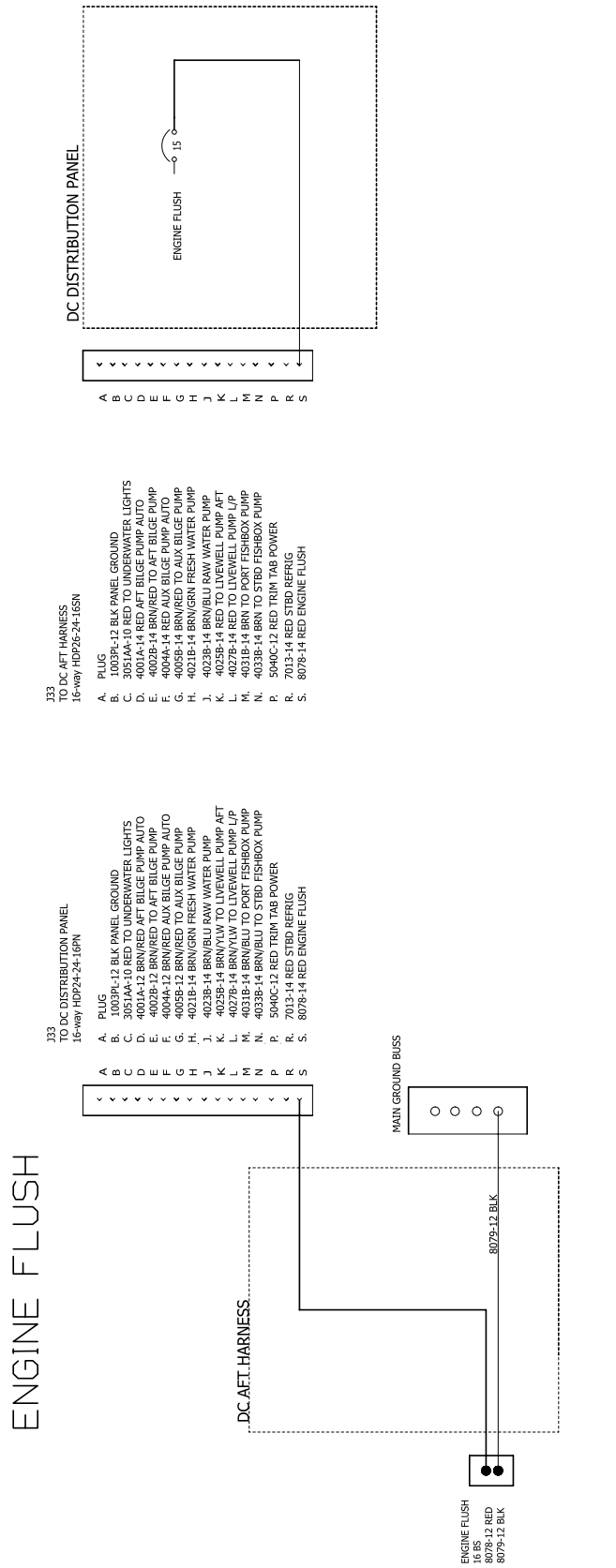

Deck Lights-STBD Schematic Figure 4.40.1

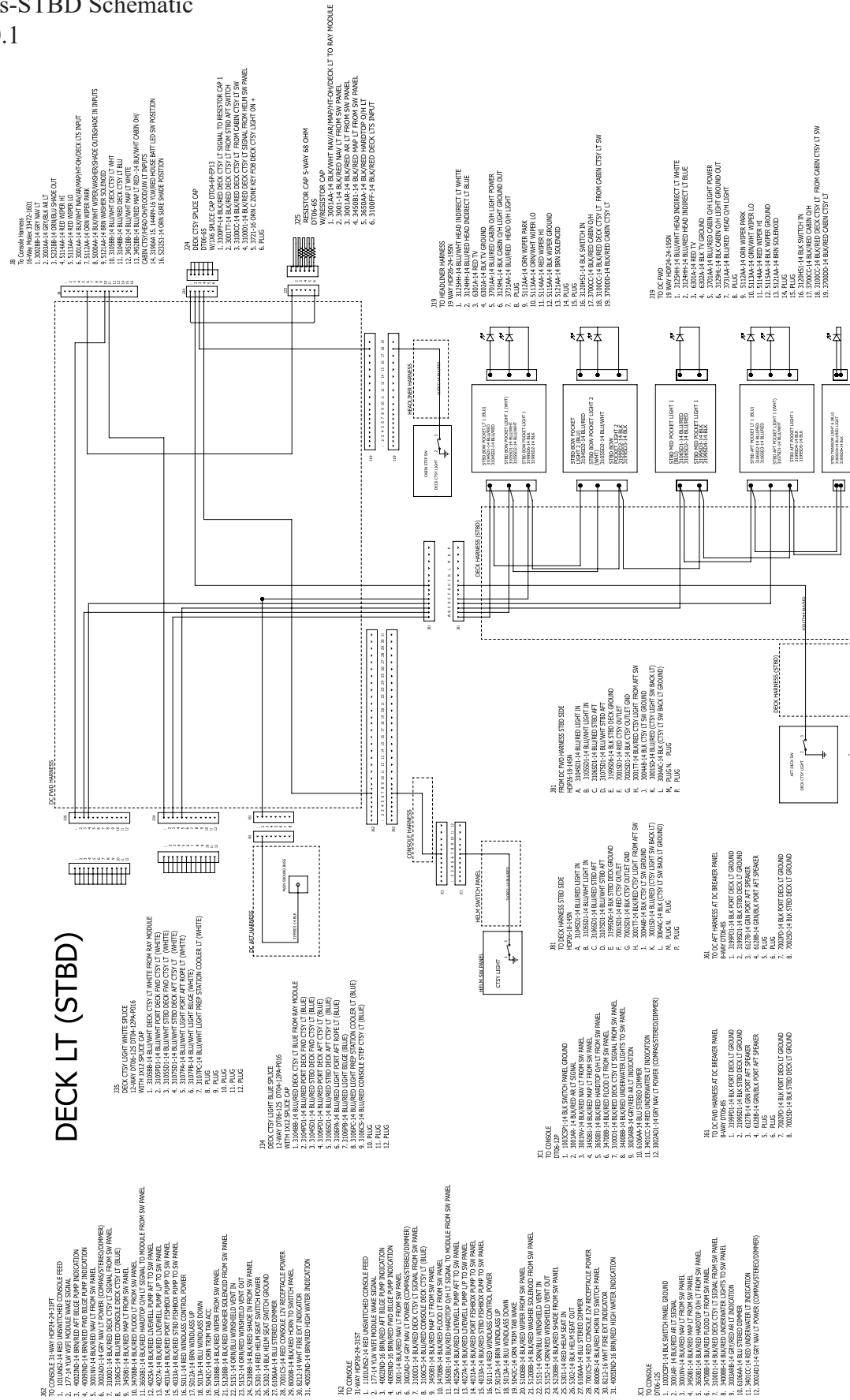

Underwater Lights Schematic
Figure 4.41.1

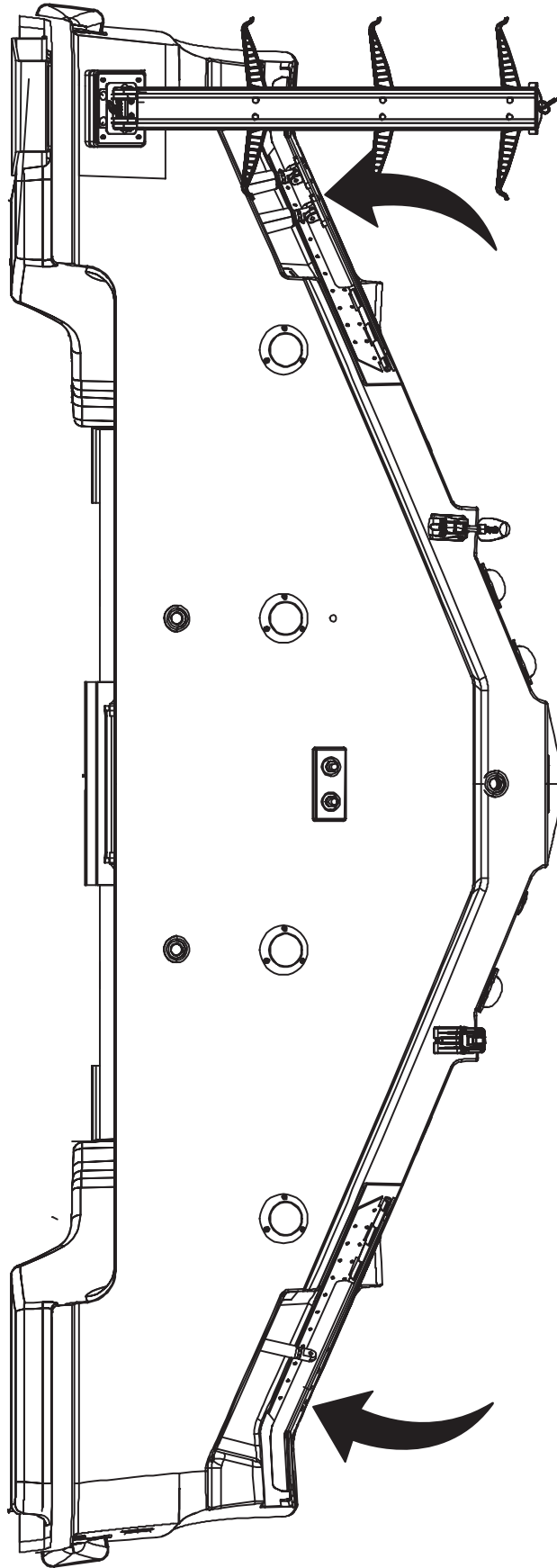

Hardtop Lights Schematic
Figure 4.43.1

HARDTOP LIGHTS

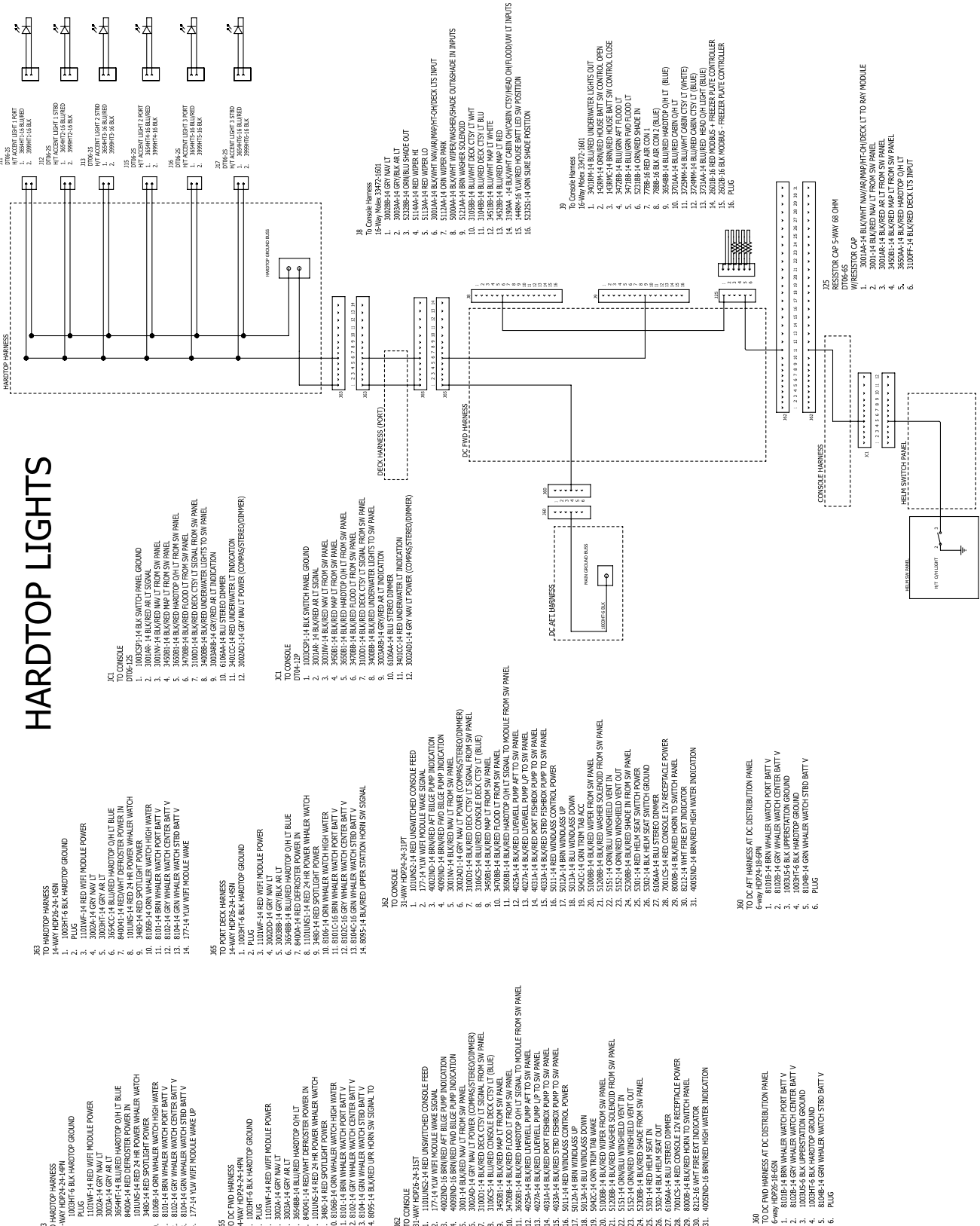

Nav Lights Schematic
Figure 4.45.1

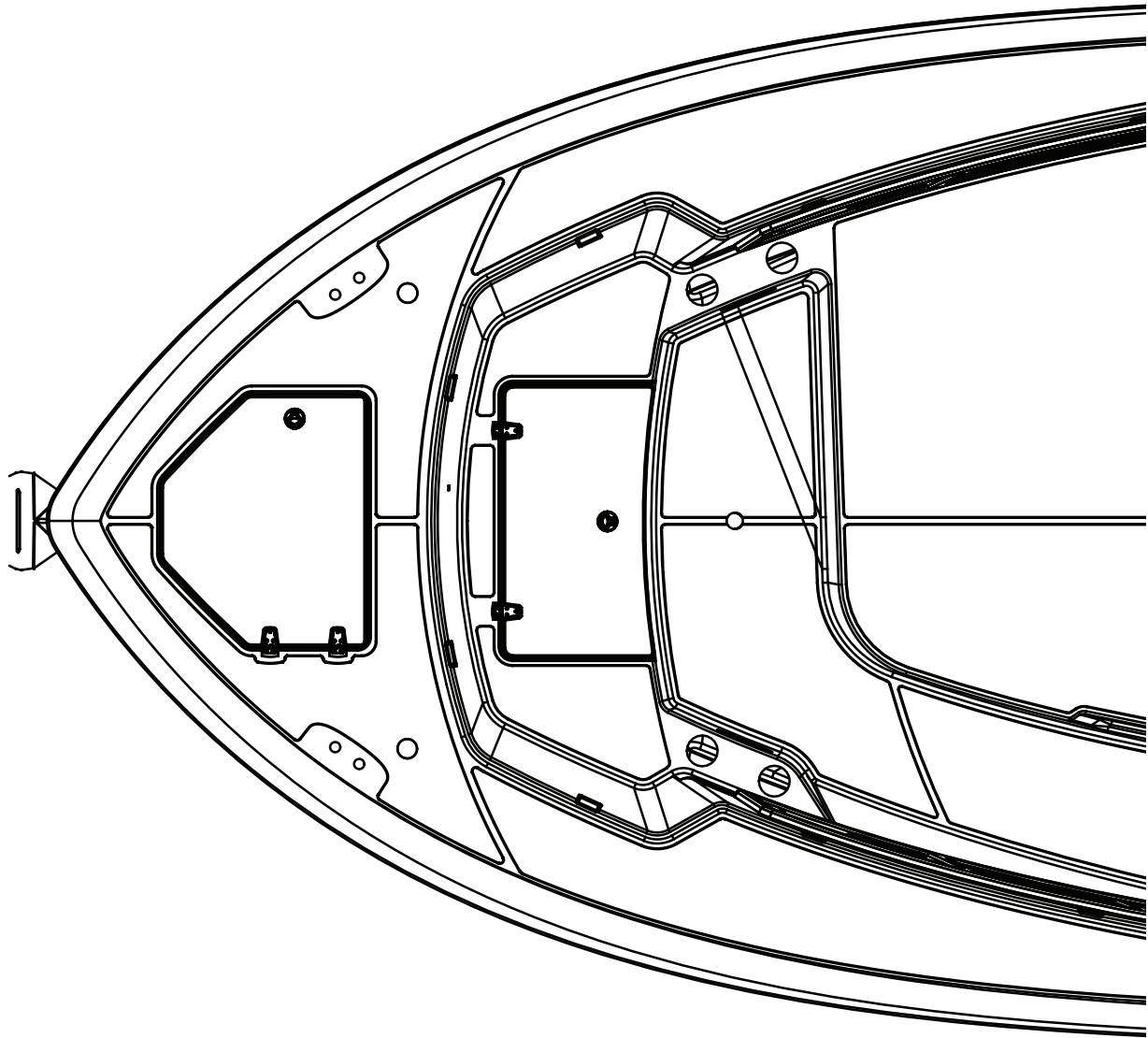

Spot Lights Schematic
Figure 4.47.1

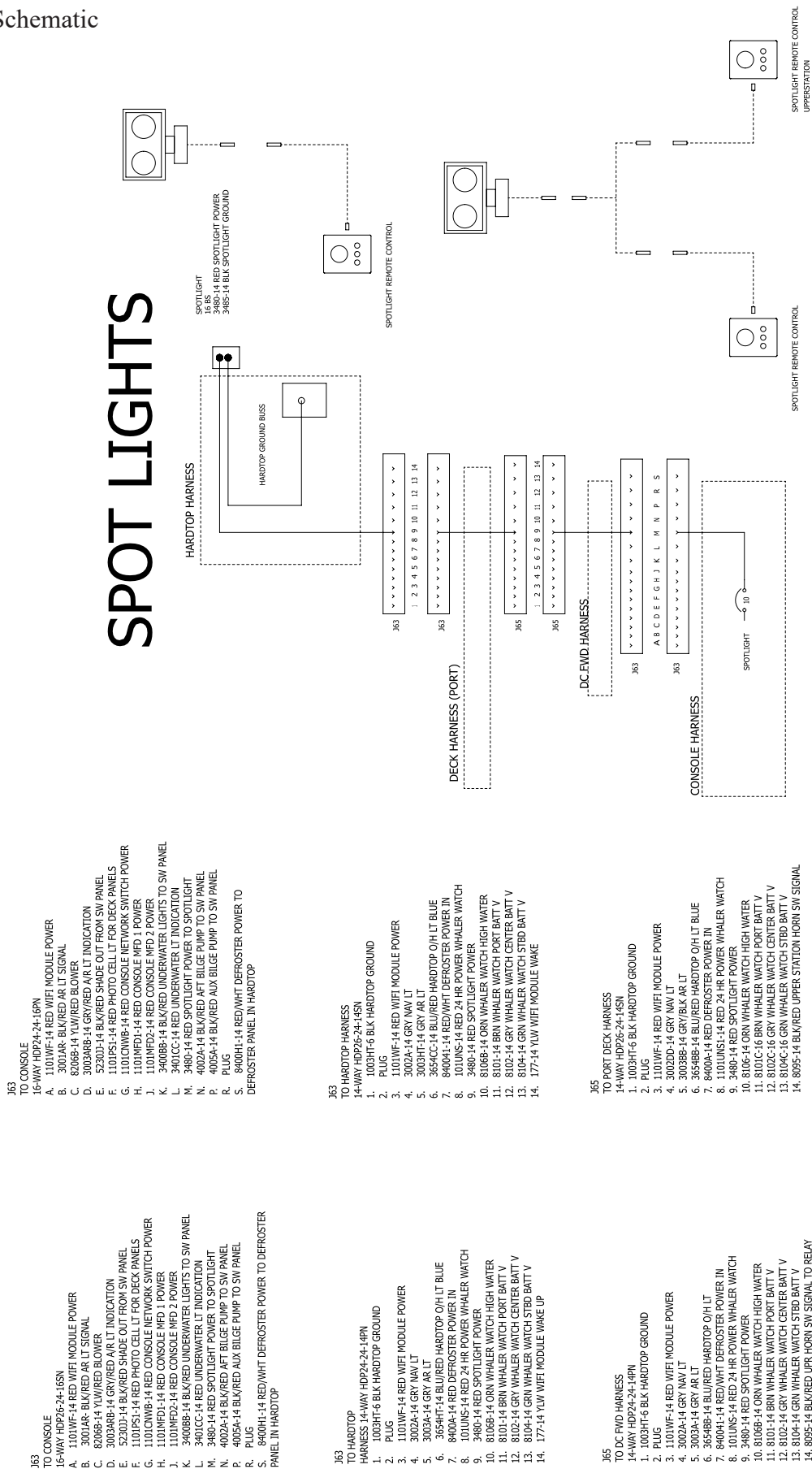

Cabin Overhead Lights Schematic

Figure 4.48.1

CABIN O/H LIGHTS

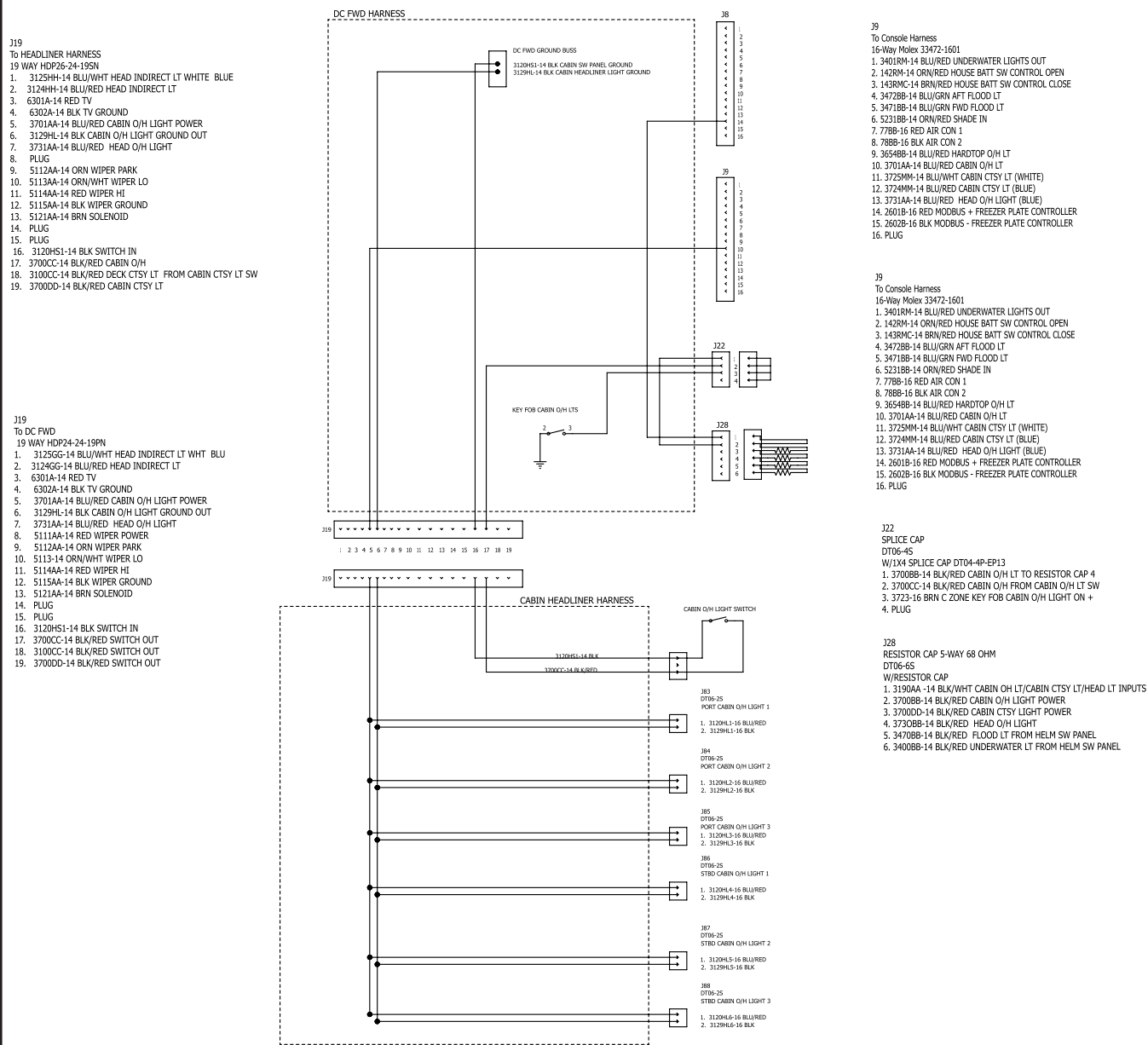

Head Overhead Lights Schematic
Figure 4.50.1

HEAD O/H LIGHTS

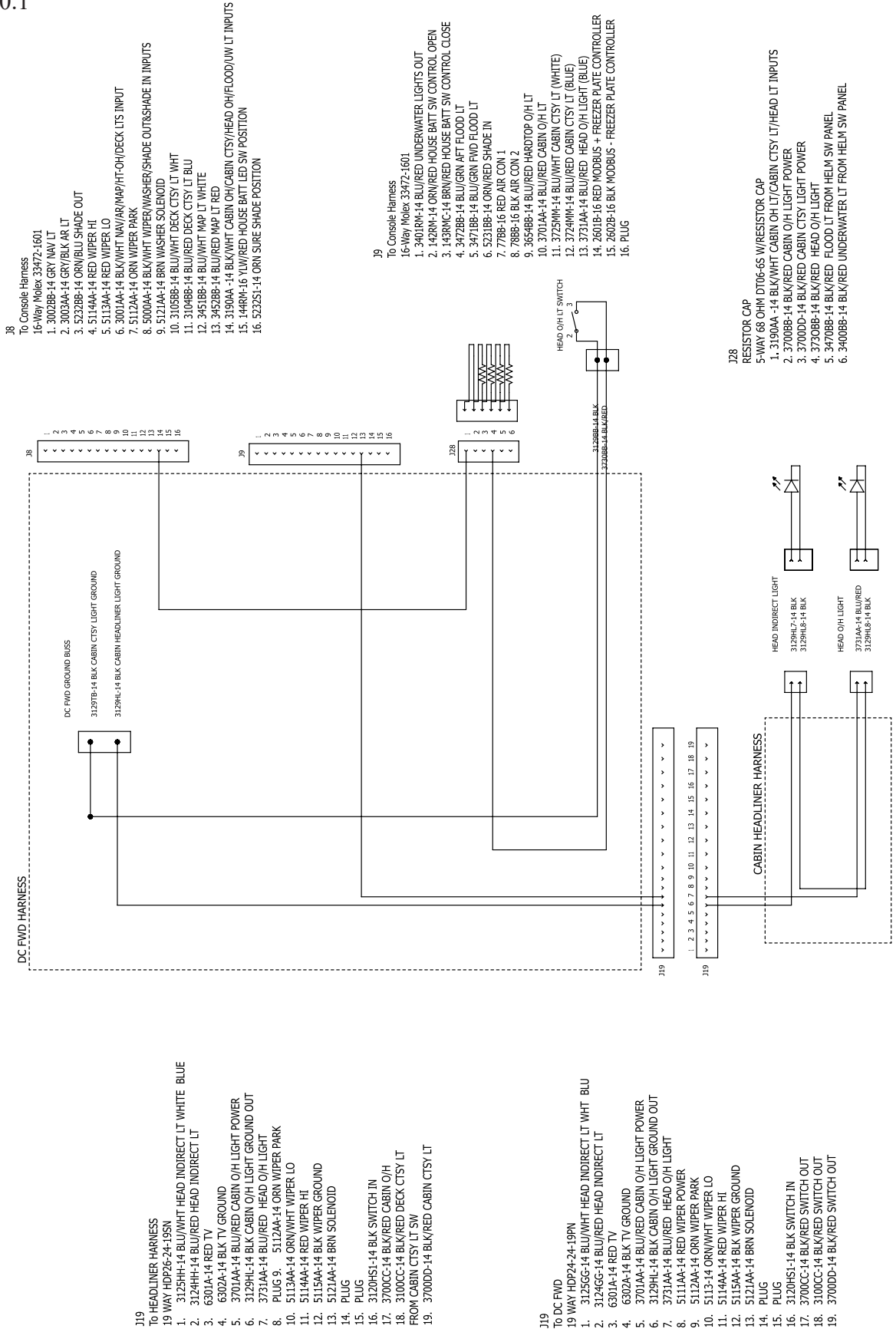

AC Mod Buss Schematic
Figure 4.51.1

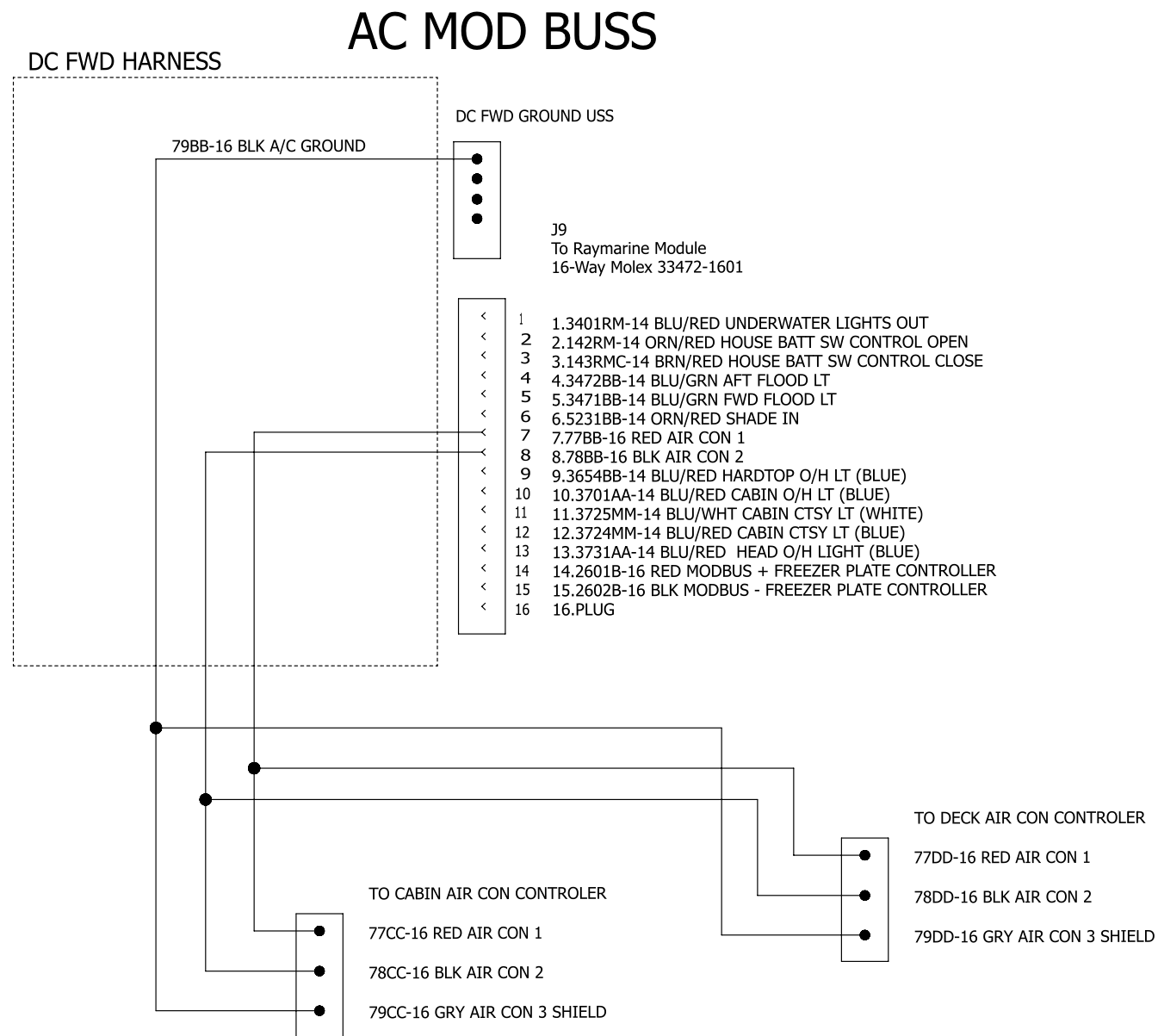

Refrigerator Schematic
Figure 4.52.1

REFRIGERATOR

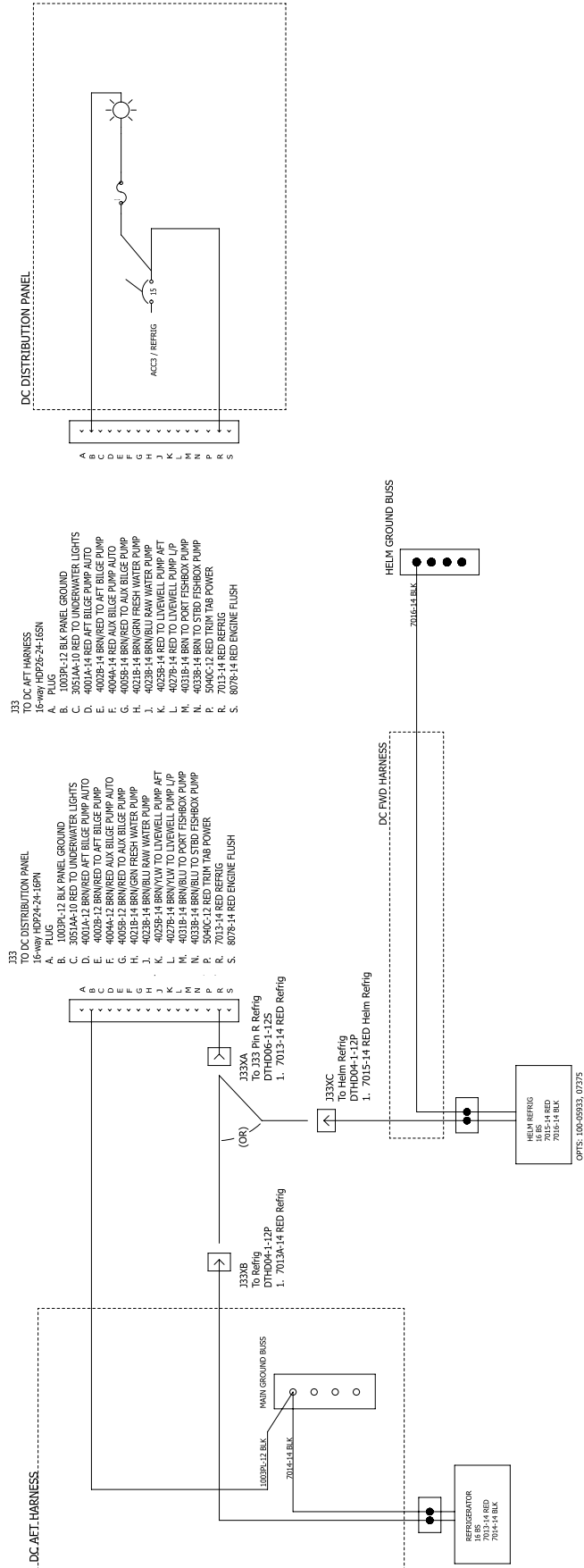

12V and USB Schematic Figure 4.53.1

12V & USB

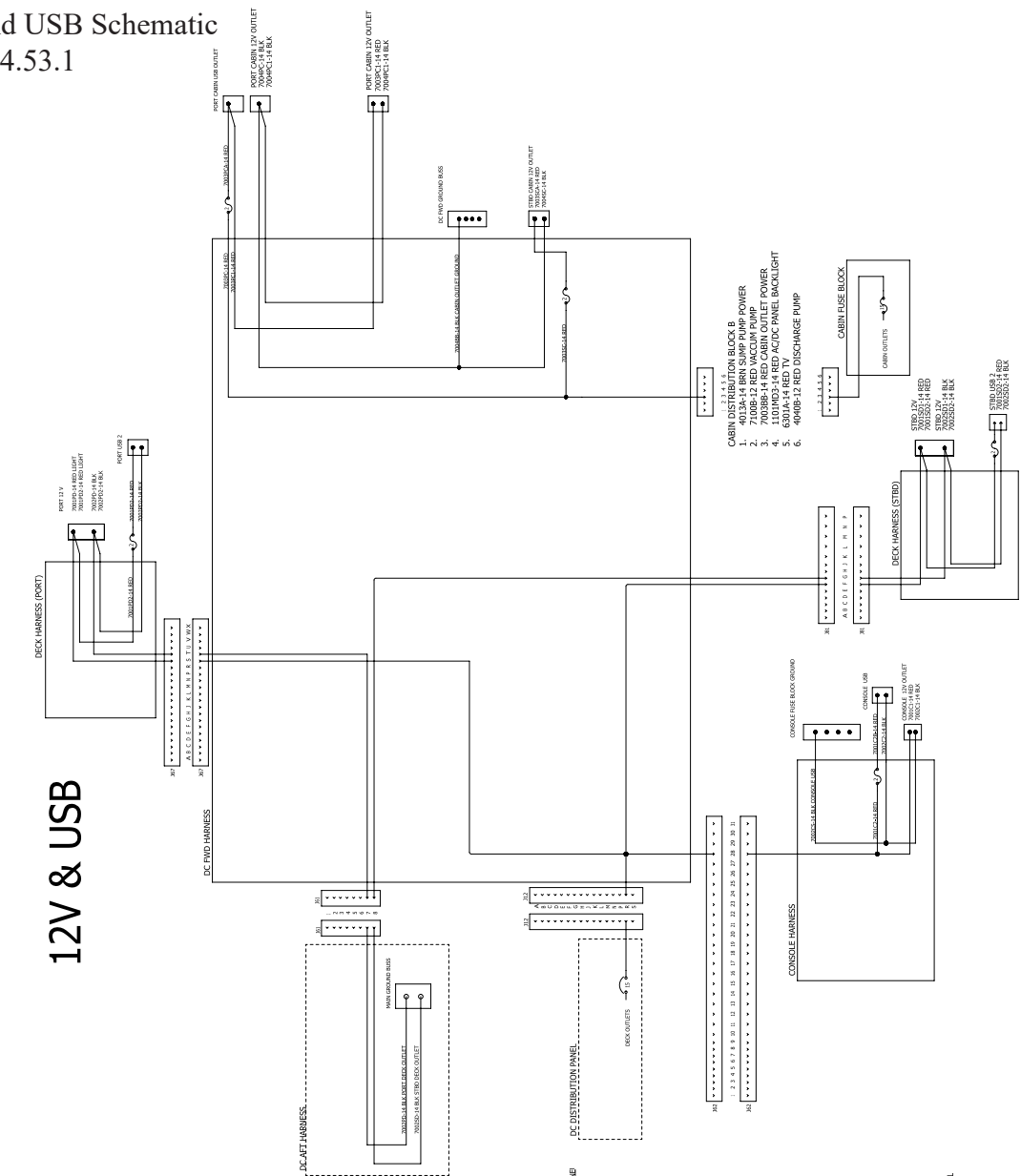

- 12V**
- 1. 12V BATTERY
 - 2. 12V BATTERY POSITIVE
 - 3. 12V BATTERY NEGATIVE
 - 4. 12V BATTERY POSITIVE
 - 5. 12V BATTERY NEGATIVE
 - 6. 12V BATTERY POSITIVE
 - 7. 12V BATTERY NEGATIVE
 - 8. 12V BATTERY POSITIVE
 - 9. 12V BATTERY NEGATIVE
 - 10. 12V BATTERY POSITIVE
 - 11. 12V BATTERY NEGATIVE
 - 12. 12V BATTERY POSITIVE
 - 13. 12V BATTERY NEGATIVE
 - 14. 12V BATTERY POSITIVE
 - 15. 12V BATTERY NEGATIVE
 - 16. 12V BATTERY POSITIVE
 - 17. 12V BATTERY NEGATIVE
 - 18. 12V BATTERY POSITIVE
 - 19. 12V BATTERY NEGATIVE
 - 20. 12V BATTERY POSITIVE
 - 21. 12V BATTERY NEGATIVE
 - 22. 12V BATTERY POSITIVE
 - 23. 12V BATTERY NEGATIVE
 - 24. 12V BATTERY POSITIVE
 - 25. 12V BATTERY NEGATIVE
 - 26. 12V BATTERY POSITIVE
 - 27. 12V BATTERY NEGATIVE
 - 28. 12V BATTERY POSITIVE
 - 29. 12V BATTERY NEGATIVE
 - 30. 12V BATTERY POSITIVE
 - 31. 12V BATTERY NEGATIVE
 - 32. 12V BATTERY POSITIVE
 - 33. 12V BATTERY NEGATIVE
 - 34. 12V BATTERY POSITIVE
 - 35. 12V BATTERY NEGATIVE
 - 36. 12V BATTERY POSITIVE
 - 37. 12V BATTERY NEGATIVE
 - 38. 12V BATTERY POSITIVE
 - 39. 12V BATTERY NEGATIVE
 - 40. 12V BATTERY POSITIVE
 - 41. 12V BATTERY NEGATIVE
 - 42. 12V BATTERY POSITIVE
 - 43. 12V BATTERY NEGATIVE
 - 44. 12V BATTERY POSITIVE
 - 45. 12V BATTERY NEGATIVE
 - 46. 12V BATTERY POSITIVE
 - 47. 12V BATTERY NEGATIVE
 - 48. 12V BATTERY POSITIVE
 - 49. 12V BATTERY NEGATIVE
 - 50. 12V BATTERY POSITIVE
 - 51. 12V BATTERY NEGATIVE
 - 52. 12V BATTERY POSITIVE
 - 53. 12V BATTERY NEGATIVE
 - 54. 12V BATTERY POSITIVE
 - 55. 12V BATTERY NEGATIVE
 - 56. 12V BATTERY POSITIVE
 - 57. 12V BATTERY NEGATIVE
 - 58. 12V BATTERY POSITIVE
 - 59. 12V BATTERY NEGATIVE
 - 60. 12V BATTERY POSITIVE
 - 61. 12V BATTERY NEGATIVE
 - 62. 12V BATTERY POSITIVE
 - 63. 12V BATTERY NEGATIVE
 - 64. 12V BATTERY POSITIVE
 - 65. 12V BATTERY NEGATIVE
 - 66. 12V BATTERY POSITIVE
 - 67. 12V BATTERY NEGATIVE
 - 68. 12V BATTERY POSITIVE
 - 69. 12V BATTERY NEGATIVE
 - 70. 12V BATTERY POSITIVE
 - 71. 12V BATTERY NEGATIVE
 - 72. 12V BATTERY POSITIVE
 - 73. 12V BATTERY NEGATIVE
 - 74. 12V BATTERY POSITIVE
 - 75. 12V BATTERY NEGATIVE
 - 76. 12V BATTERY POSITIVE
 - 77. 12V BATTERY NEGATIVE
 - 78. 12V BATTERY POSITIVE
 - 79. 12V BATTERY NEGATIVE
 - 80. 12V BATTERY POSITIVE
 - 81. 12V BATTERY NEGATIVE
 - 82. 12V BATTERY POSITIVE
 - 83. 12V BATTERY NEGATIVE
 - 84. 12V BATTERY POSITIVE
 - 85. 12V BATTERY NEGATIVE
 - 86. 12V BATTERY POSITIVE
 - 87. 12V BATTERY NEGATIVE
 - 88. 12V BATTERY POSITIVE
 - 89. 12V BATTERY NEGATIVE
 - 90. 12V BATTERY POSITIVE
 - 91. 12V BATTERY NEGATIVE
 - 92. 12V BATTERY POSITIVE
 - 93. 12V BATTERY NEGATIVE
 - 94. 12V BATTERY POSITIVE
 - 95. 12V BATTERY NEGATIVE
 - 96. 12V BATTERY POSITIVE
 - 97. 12V BATTERY NEGATIVE
 - 98. 12V BATTERY POSITIVE
 - 99. 12V BATTERY NEGATIVE
 - 100. 12V BATTERY POSITIVE
- USB**
- 1. USB PORT 1
 - 2. USB PORT 2
 - 3. USB PORT 3
 - 4. USB PORT 4
 - 5. USB PORT 5
 - 6. USB PORT 6
 - 7. USB PORT 7
 - 8. USB PORT 8
 - 9. USB PORT 9
 - 10. USB PORT 10
 - 11. USB PORT 11
 - 12. USB PORT 12
 - 13. USB PORT 13
 - 14. USB PORT 14
 - 15. USB PORT 15
 - 16. USB PORT 16
 - 17. USB PORT 17
 - 18. USB PORT 18
 - 19. USB PORT 19
 - 20. USB PORT 20
 - 21. USB PORT 21
 - 22. USB PORT 22
 - 23. USB PORT 23
 - 24. USB PORT 24
 - 25. USB PORT 25
 - 26. USB PORT 26
 - 27. USB PORT 27
 - 28. USB PORT 28
 - 29. USB PORT 29
 - 30. USB PORT 30
 - 31. USB PORT 31
 - 32. USB PORT 32
 - 33. USB PORT 33
 - 34. USB PORT 34
 - 35. USB PORT 35
 - 36. USB PORT 36
 - 37. USB PORT 37
 - 38. USB PORT 38
 - 39. USB PORT 39
 - 40. USB PORT 40
 - 41. USB PORT 41
 - 42. USB PORT 42
 - 43. USB PORT 43
 - 44. USB PORT 44
 - 45. USB PORT 45
 - 46. USB PORT 46
 - 47. USB PORT 47
 - 48. USB PORT 48
 - 49. USB PORT 49
 - 50. USB PORT 50
 - 51. USB PORT 51
 - 52. USB PORT 52
 - 53. USB PORT 53
 - 54. USB PORT 54
 - 55. USB PORT 55
 - 56. USB PORT 56
 - 57. USB PORT 57
 - 58. USB PORT 58
 - 59. USB PORT 59
 - 60. USB PORT 60
 - 61. USB PORT 61
 - 62. USB PORT 62
 - 63. USB PORT 63
 - 64. USB PORT 64
 - 65. USB PORT 65
 - 66. USB PORT 66
 - 67. USB PORT 67
 - 68. USB PORT 68
 - 69. USB PORT 69
 - 70. USB PORT 70
 - 71. USB PORT 71
 - 72. USB PORT 72
 - 73. USB PORT 73
 - 74. USB PORT 74
 - 75. USB PORT 75
 - 76. USB PORT 76
 - 77. USB PORT 77
 - 78. USB PORT 78
 - 79. USB PORT 79
 - 80. USB PORT 80
 - 81. USB PORT 81
 - 82. USB PORT 82
 - 83. USB PORT 83
 - 84. USB PORT 84
 - 85. USB PORT 85
 - 86. USB PORT 86
 - 87. USB PORT 87
 - 88. USB PORT 88
 - 89. USB PORT 89
 - 90. USB PORT 90
 - 91. USB PORT 91
 - 92. USB PORT 92
 - 93. USB PORT 93
 - 94. USB PORT 94
 - 95. USB PORT 95
 - 96. USB PORT 96
 - 97. USB PORT 97
 - 98. USB PORT 98
 - 99. USB PORT 99
 - 100. USB PORT 100

CO Monitor Schematic
Figure 4.54.1

CO MONITOR

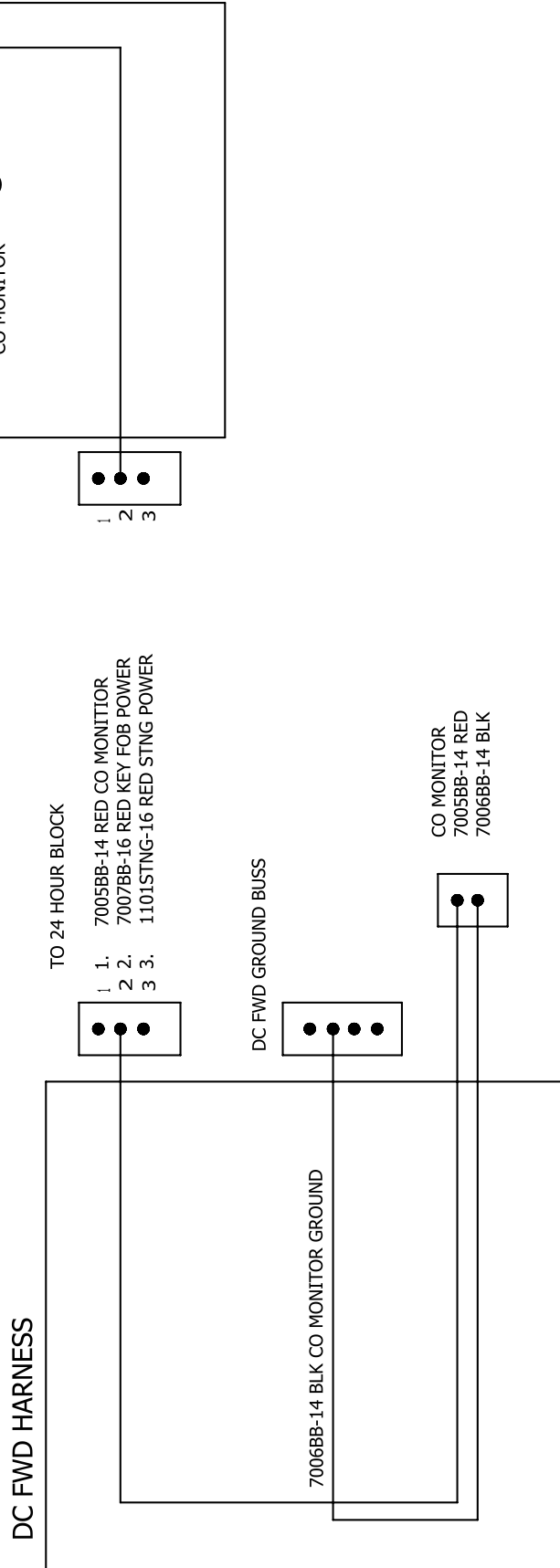

Bow Table Schematic
Figure 4.55.1

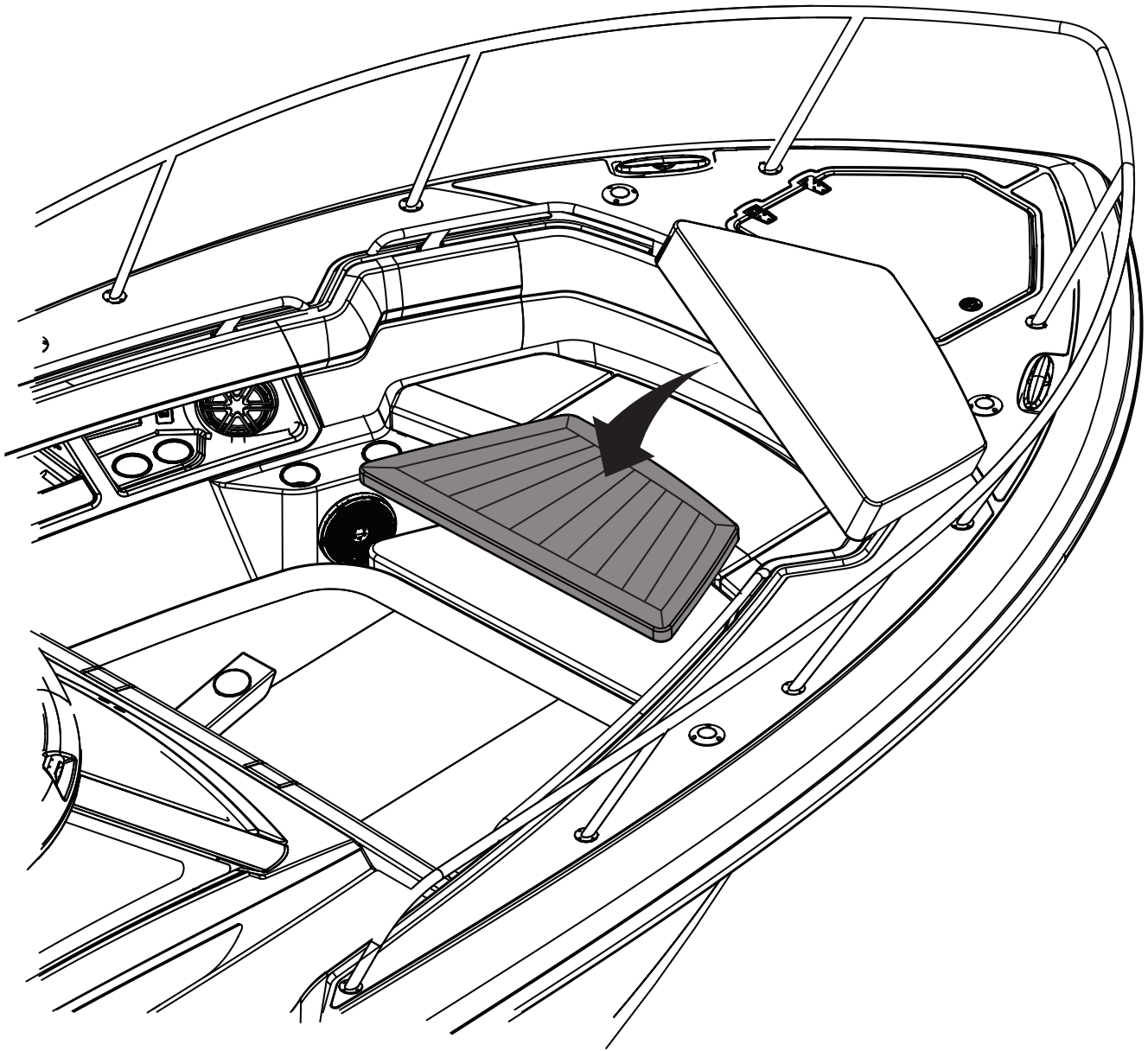

TV Schematic
Figure 4.56.1

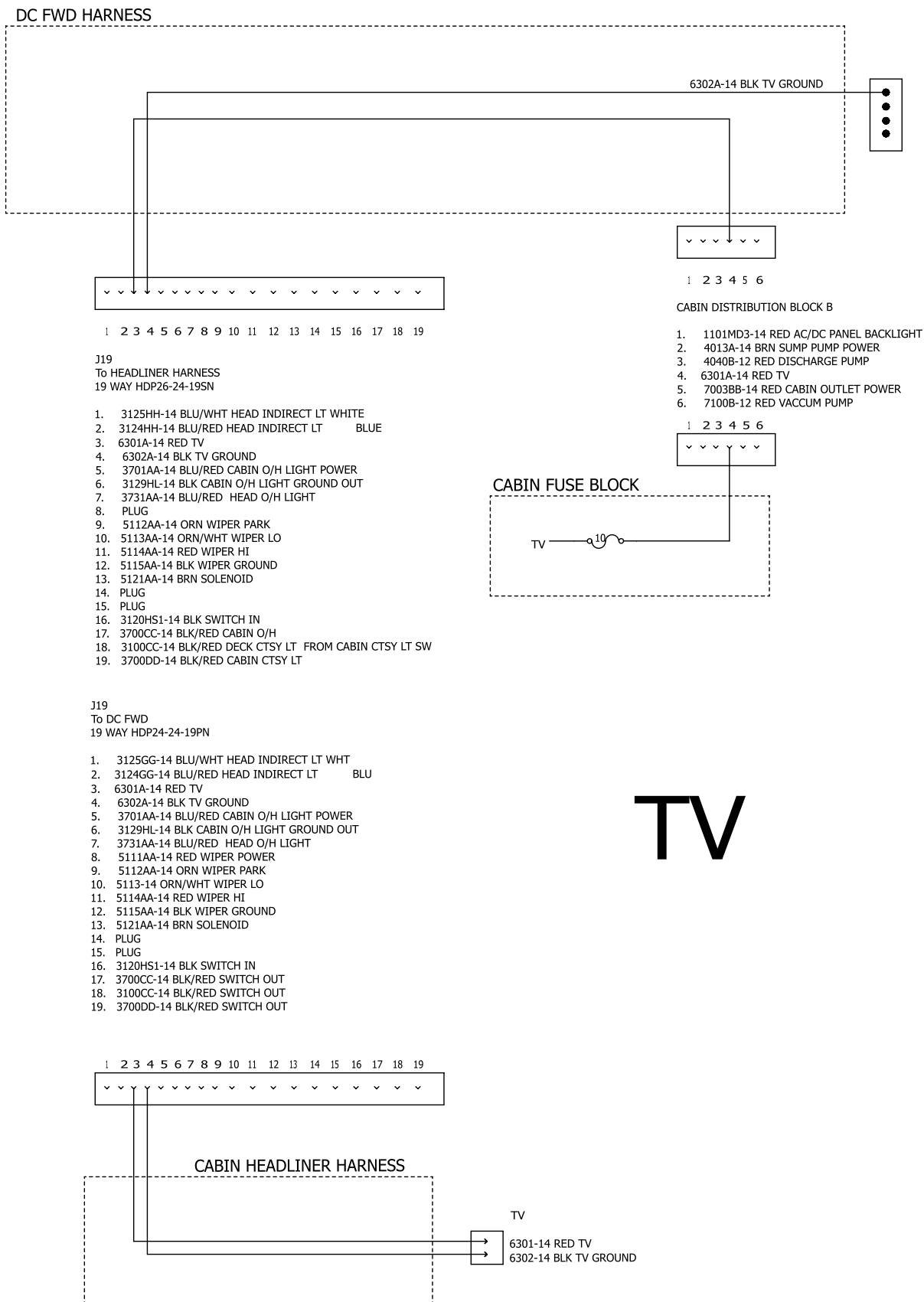

Electronics Schematic
Figure 4.58.1

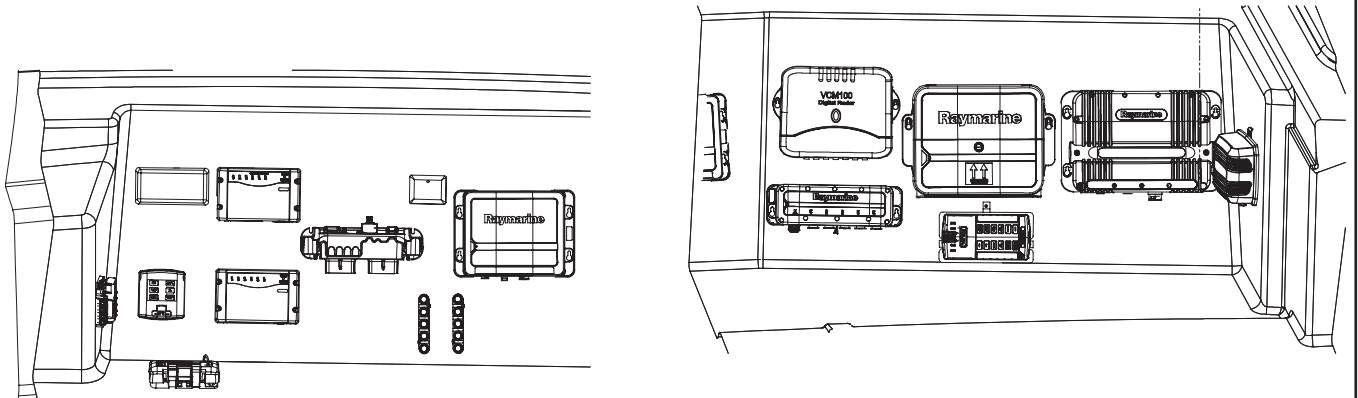

Bilge Pumps Schematic
Figure 4.59.1

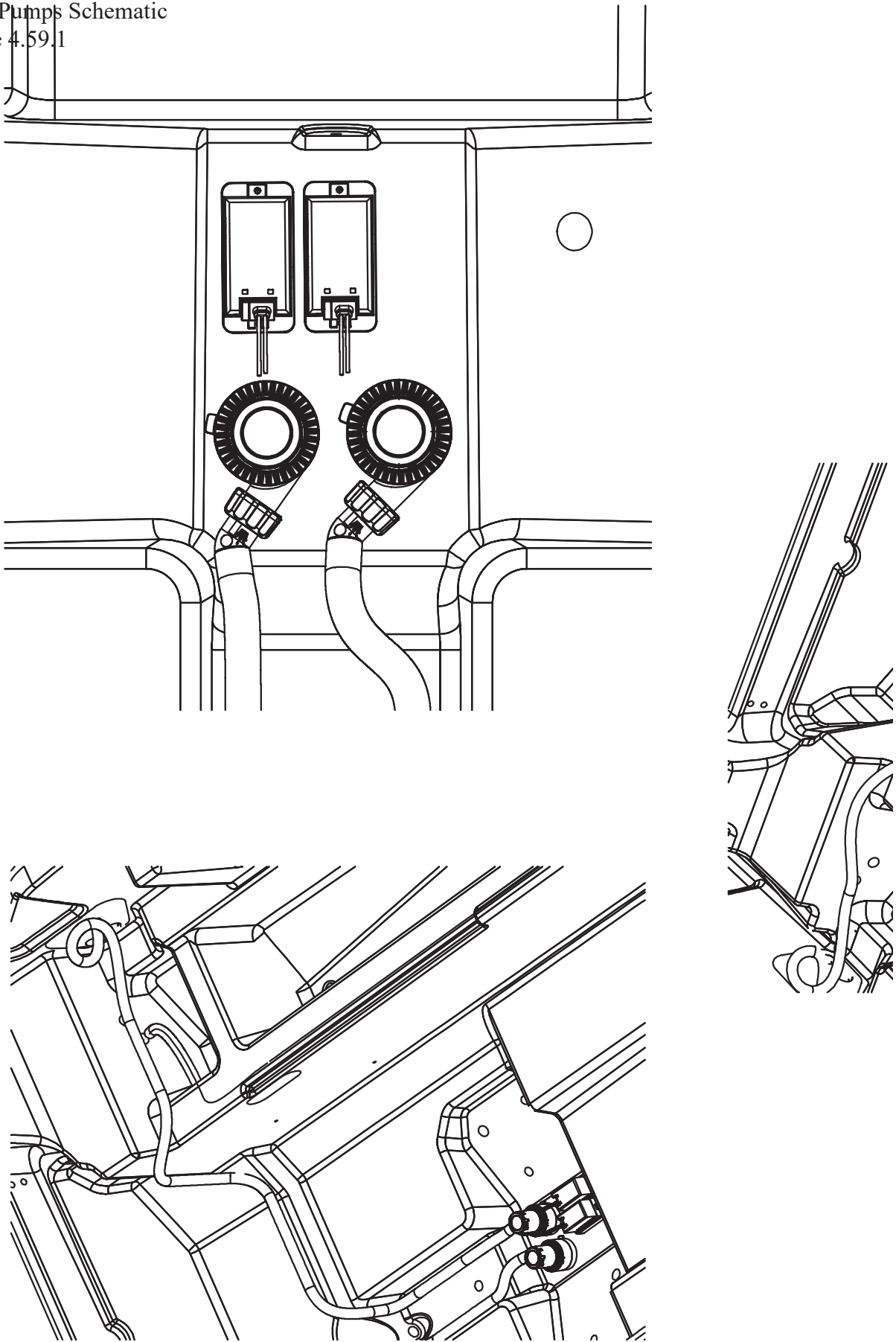

Pumps Schematic
Figure 4.60.1

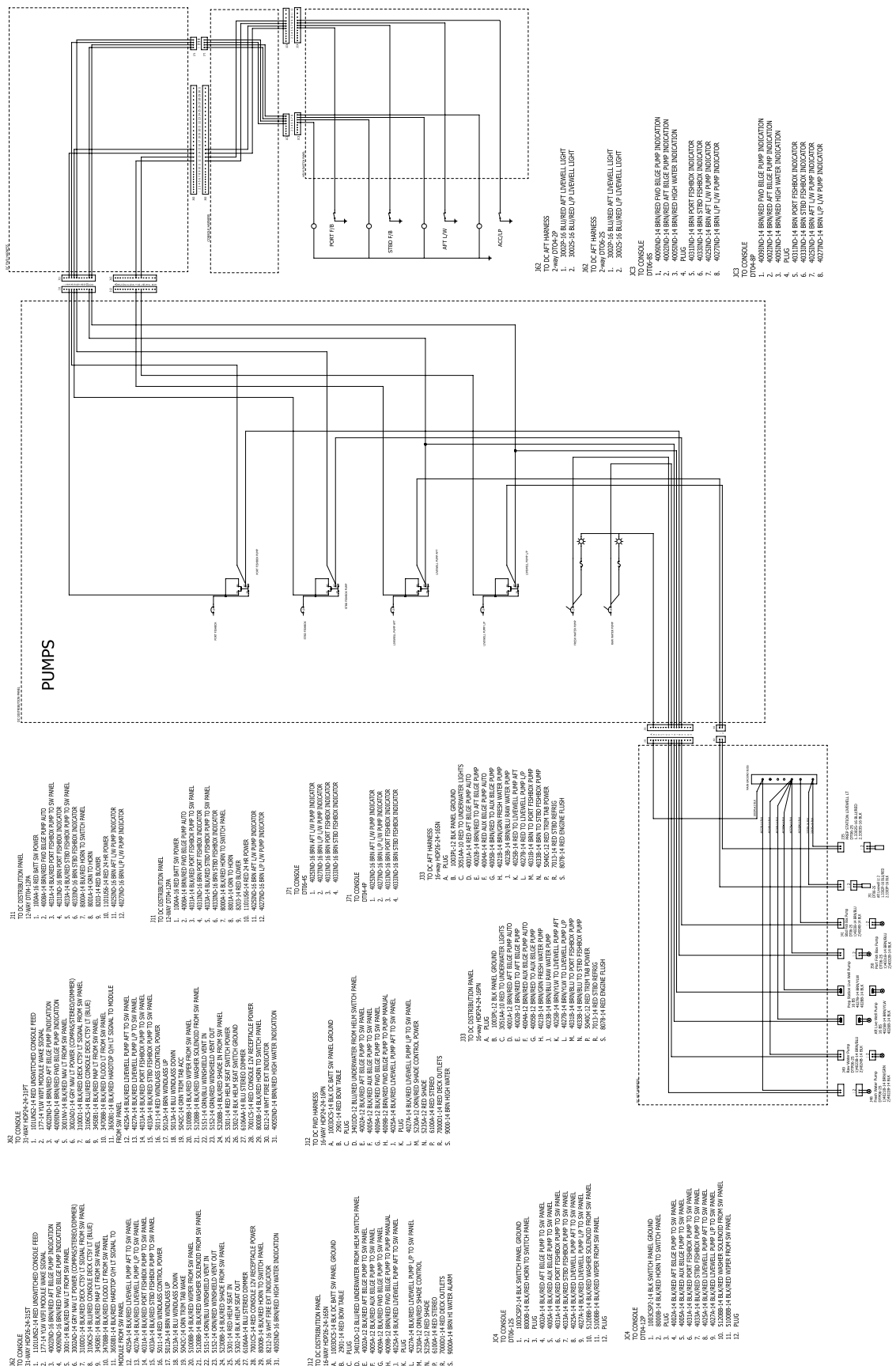

Sump Pump Schematic
Figure 4.61.1



Audio Schematic Figure 4.63.1

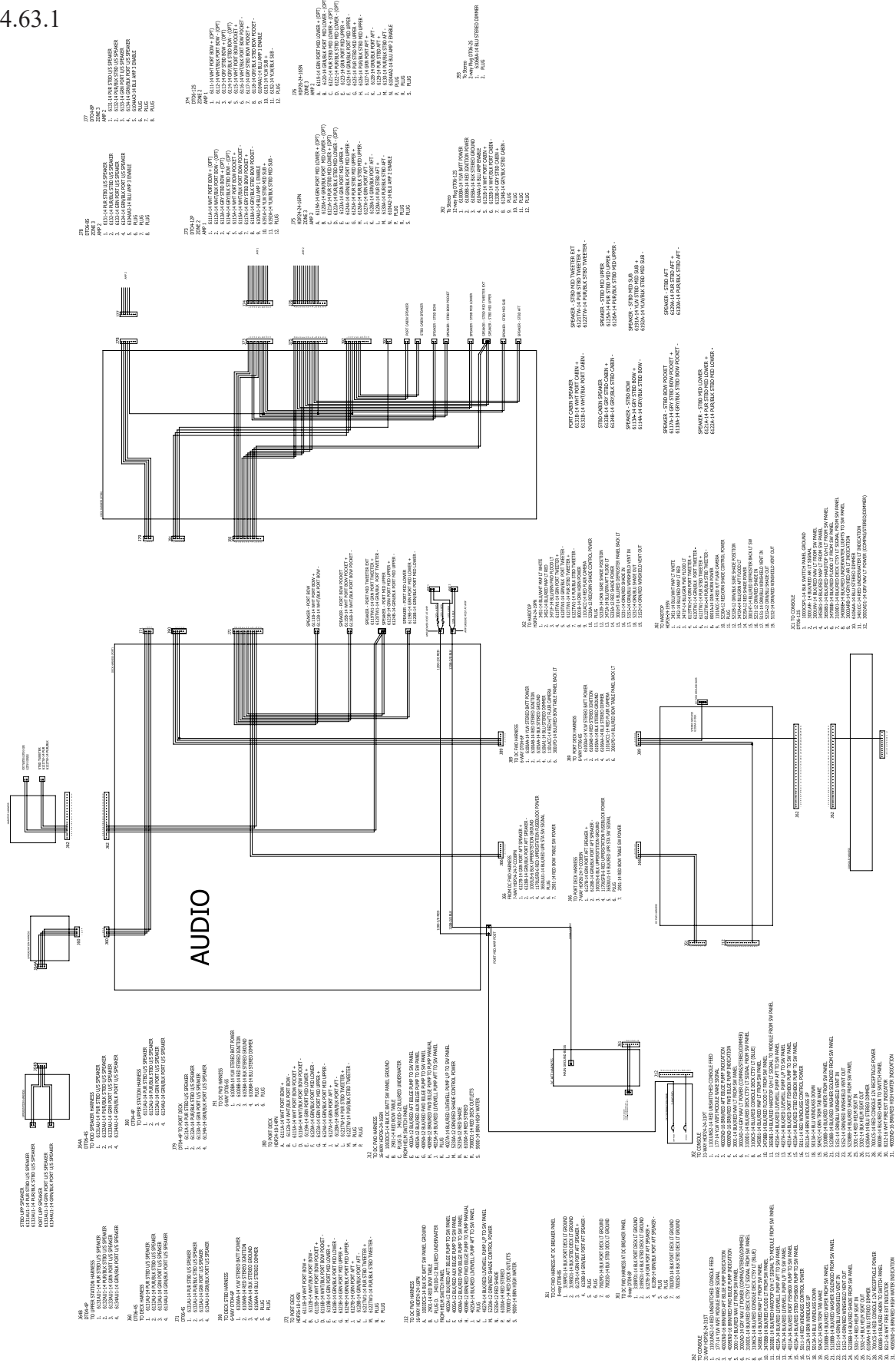

Defroster Schematic
Figure 4.65.1

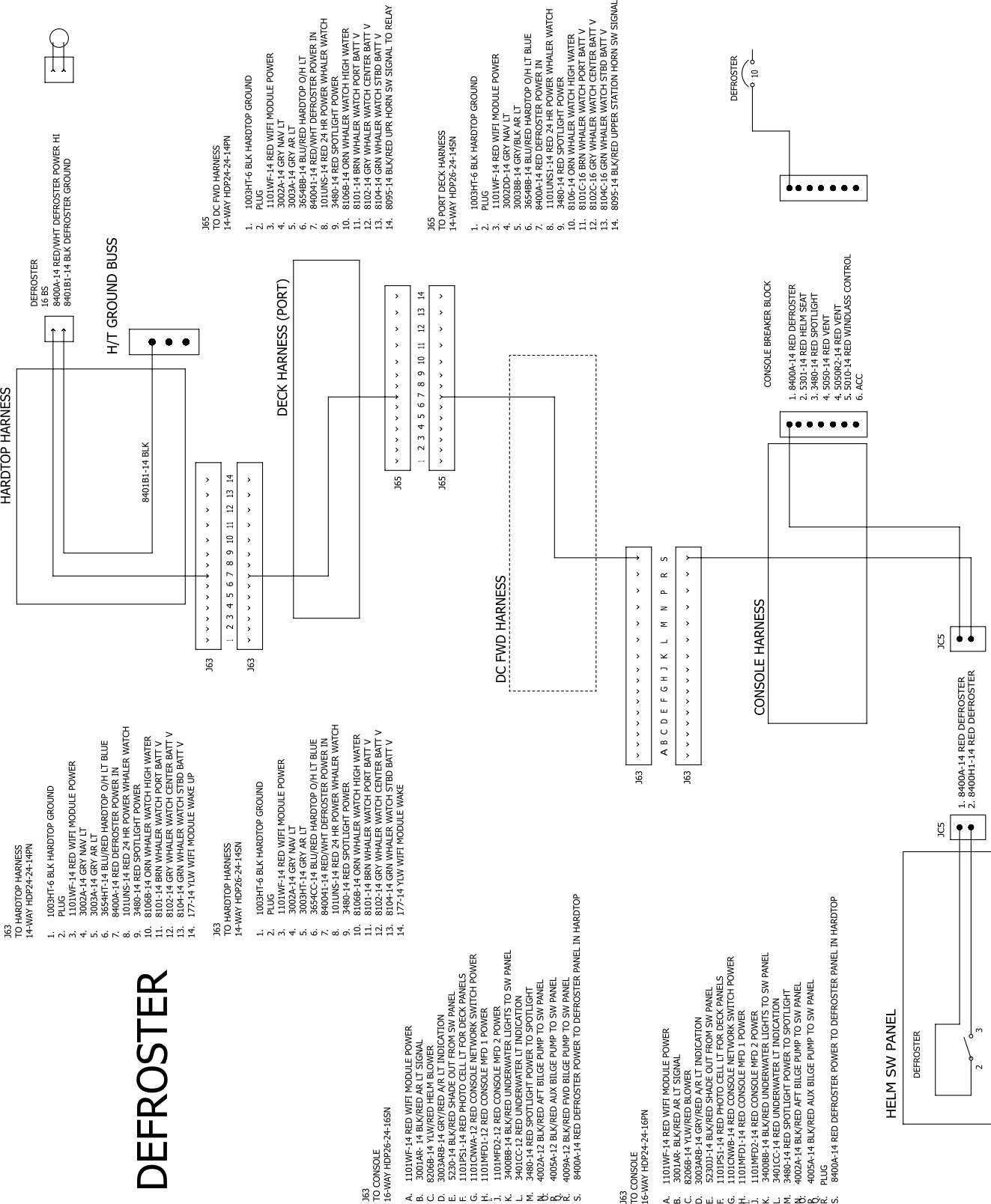

Key Fob Schematic
Figure 4.66.1



Waste/Fuel/Water Sender Schematic
Figure 4.67.1

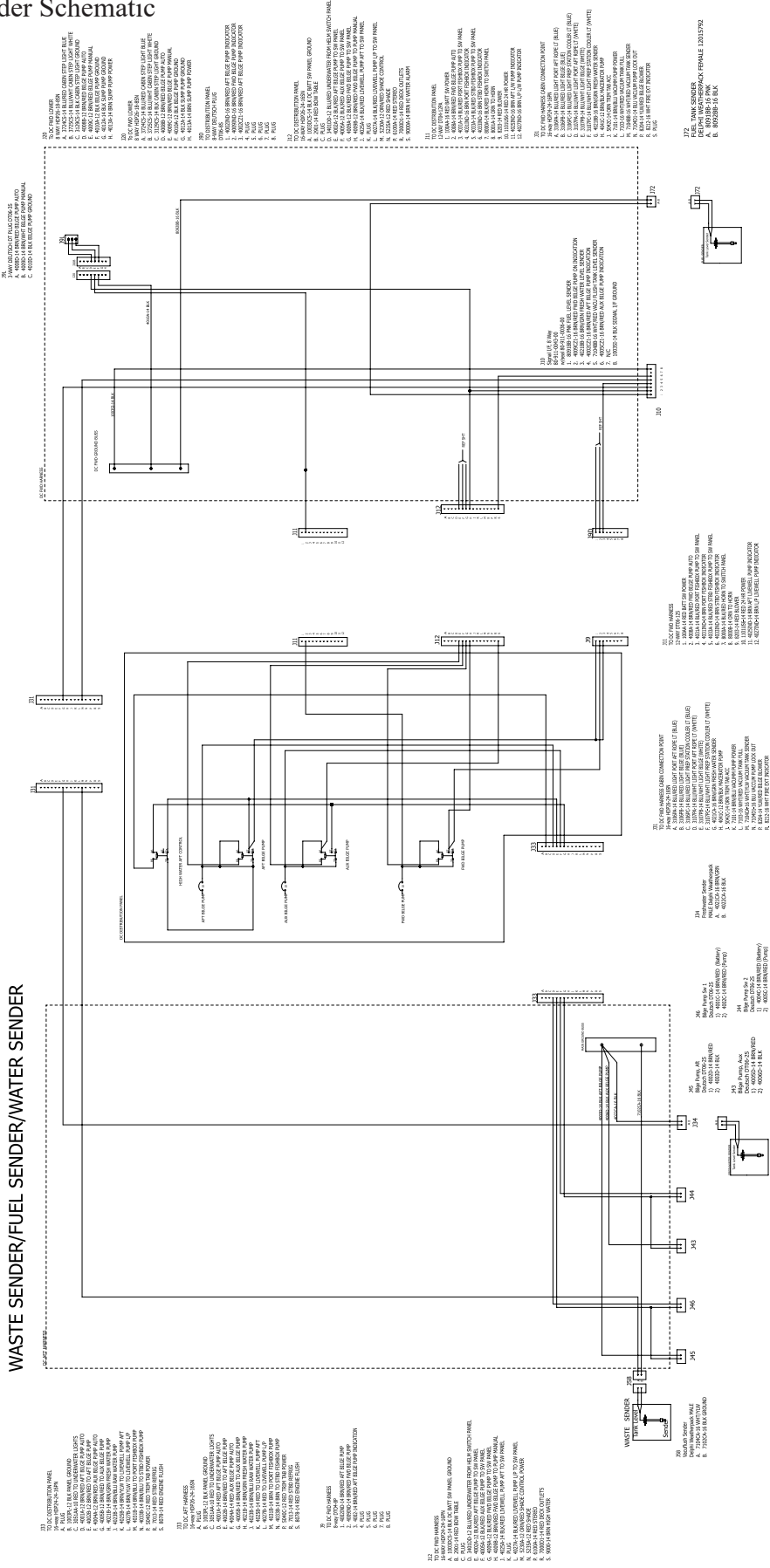

AC Monitor Schematic
Figure 4.69.1

AC MONITOR

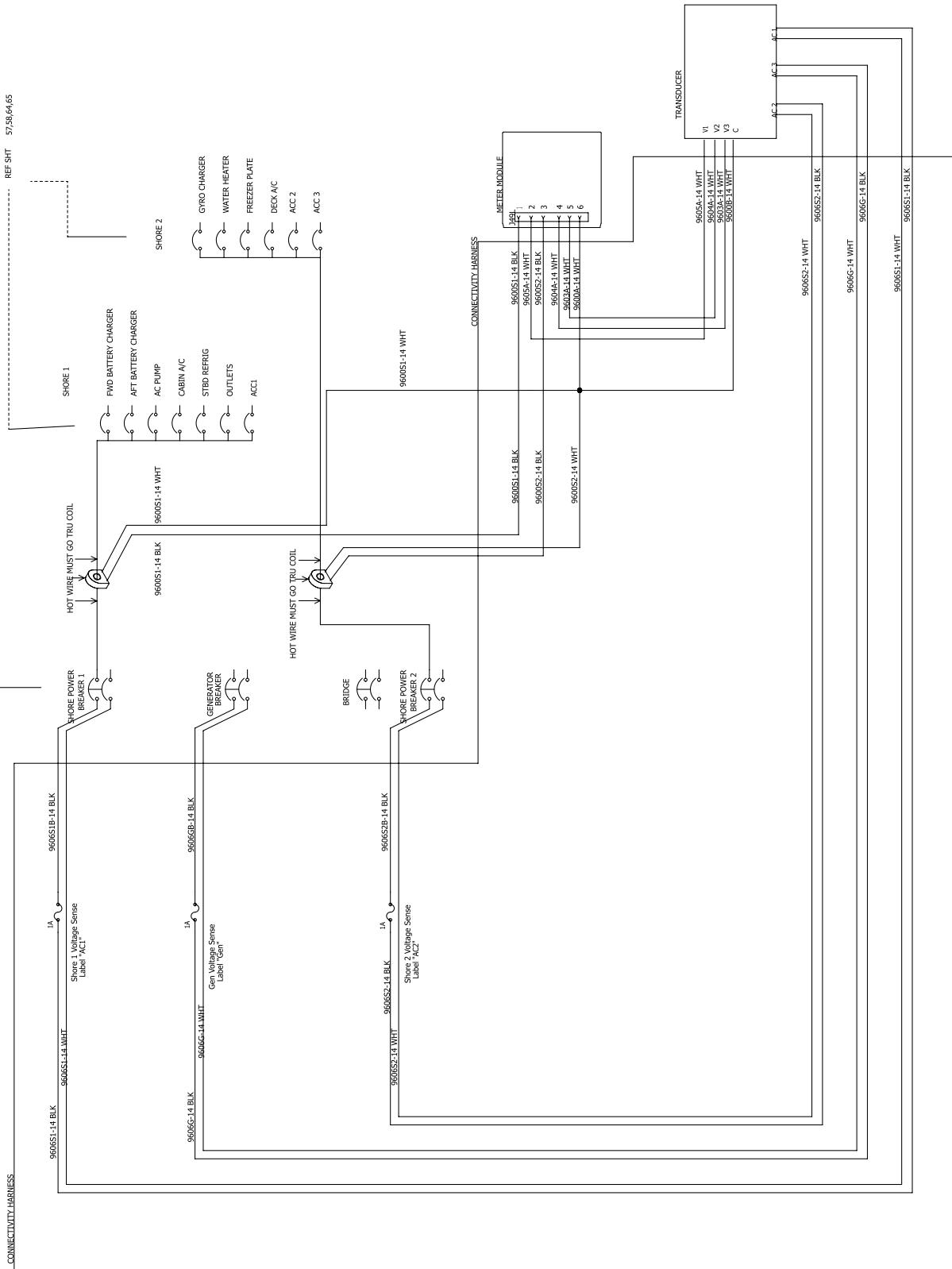

DC Main Panel Schematic
Figure 4.70.1

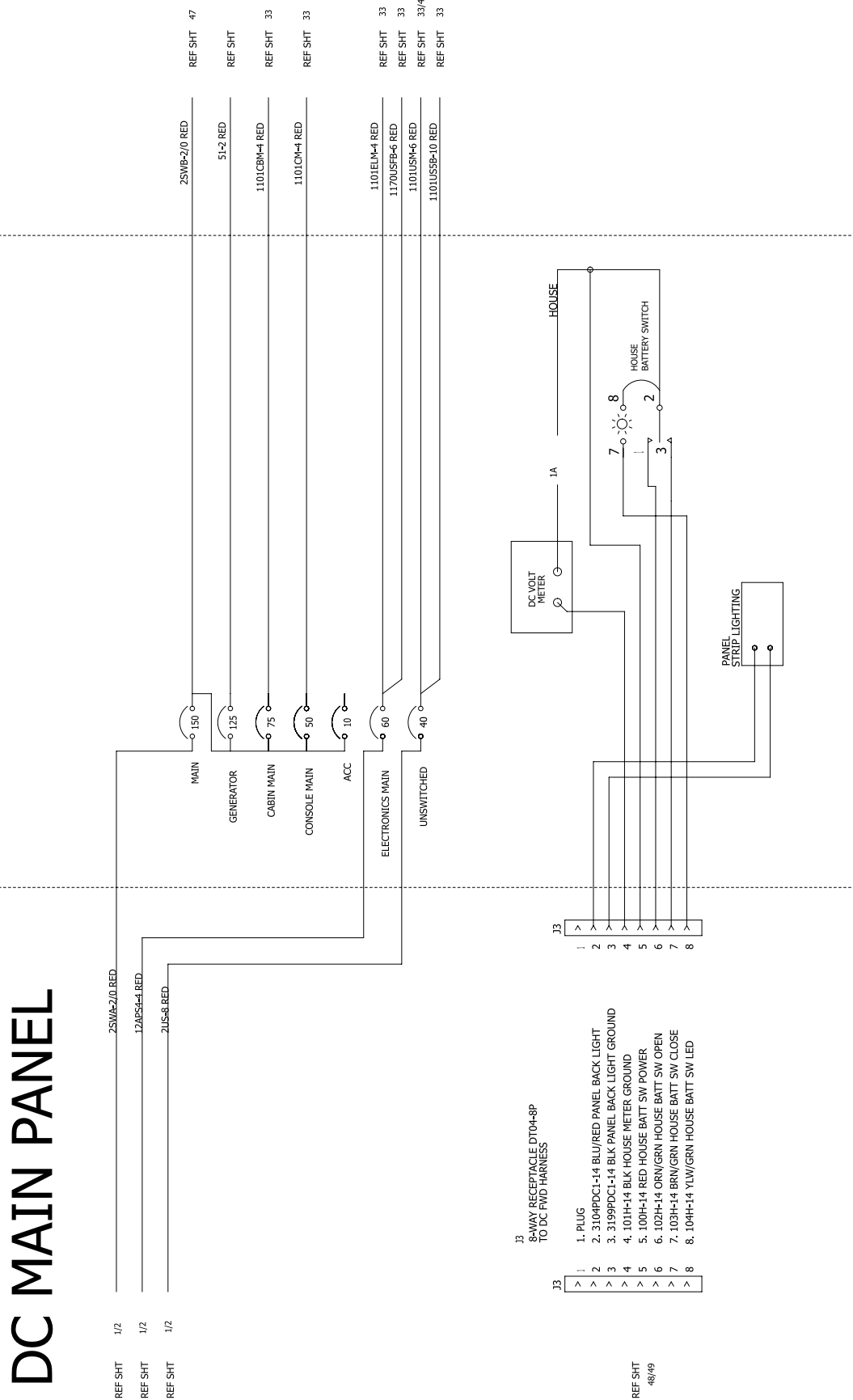

DC Distribution Panel Schematic
Figure 4.71.1

DC DISTRIBUTION PANEL

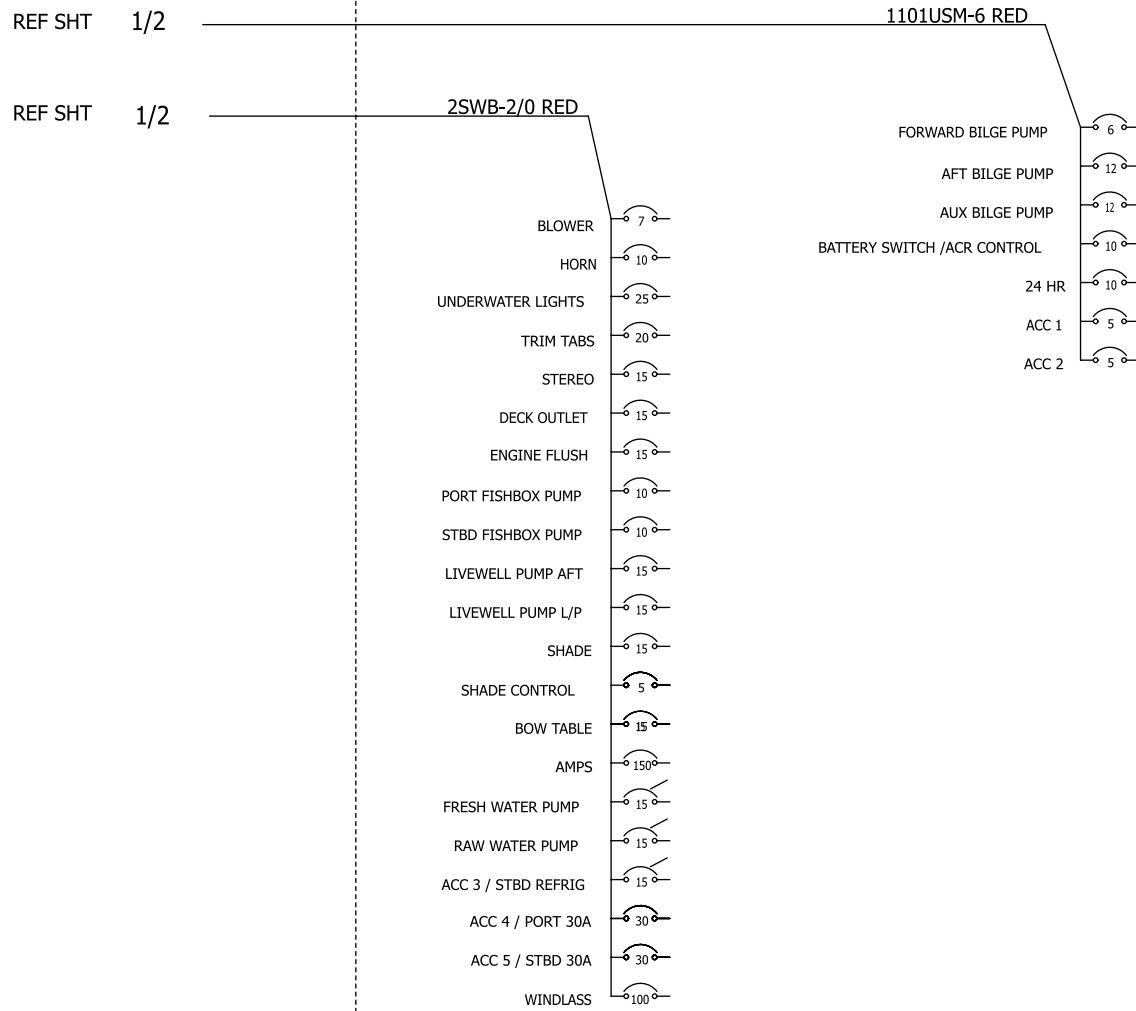

Battery Switch JPO Schematic
Figure 4.72.1

BATTERY SWITCH JPO

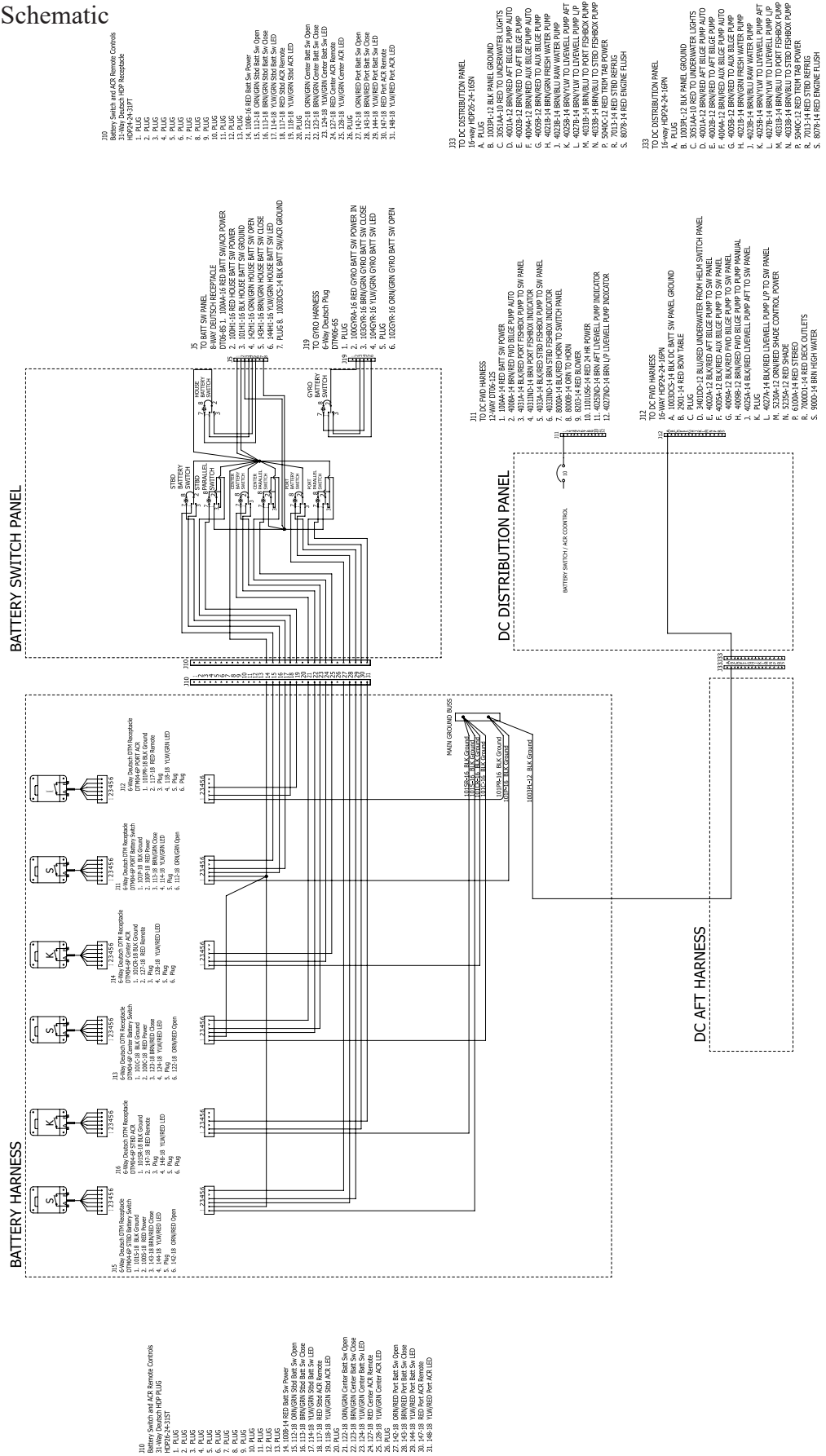

Upper Station Lighting/Upper Station Horn Schematic

Figure 4.75.1

UPPER STATION LIGHTING / UPPER STATION HORN

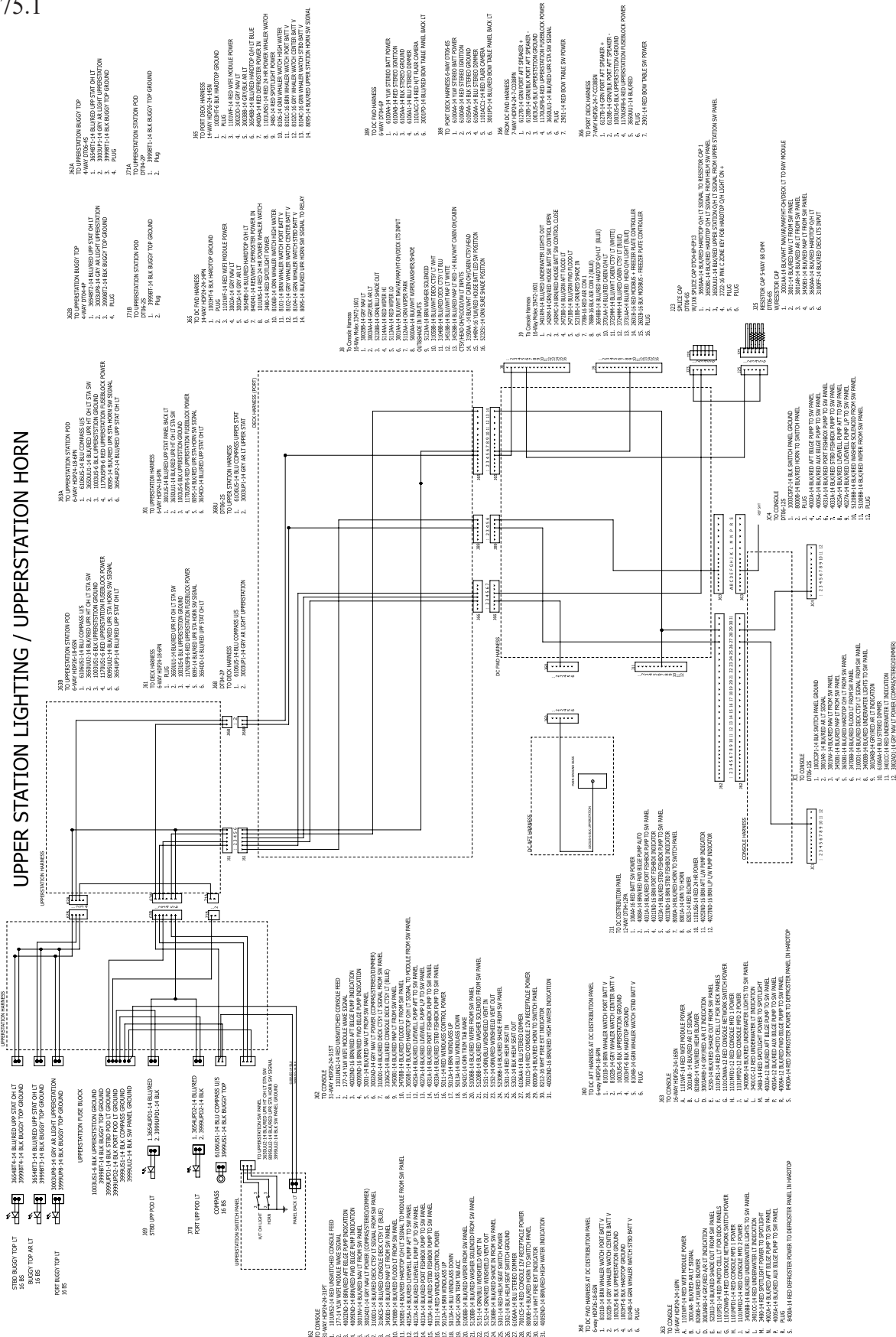

Interface Diagram
Figure 4.77.1

Meter Interface #01
Addr 0100 0000
Cabin - Port

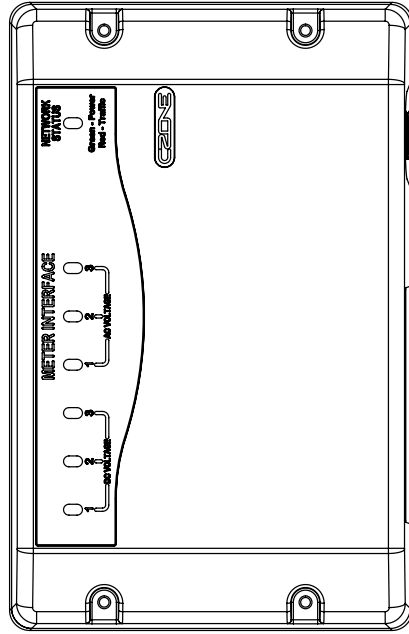

Signal Interface #02
Addr 0000 1000
Cabin - Port

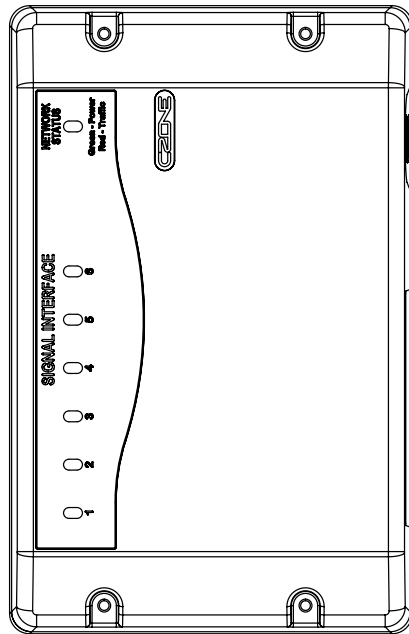

1 2 3 4 5 6 8

BEP ACVSEN-4

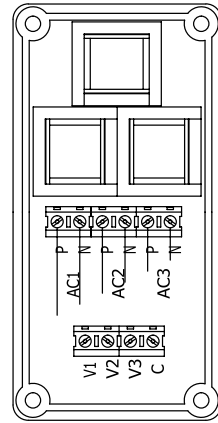

AC 120V Shore Power Inlet Schematic
Figure 4.78.1

AC 120V SHORE POWER INLET

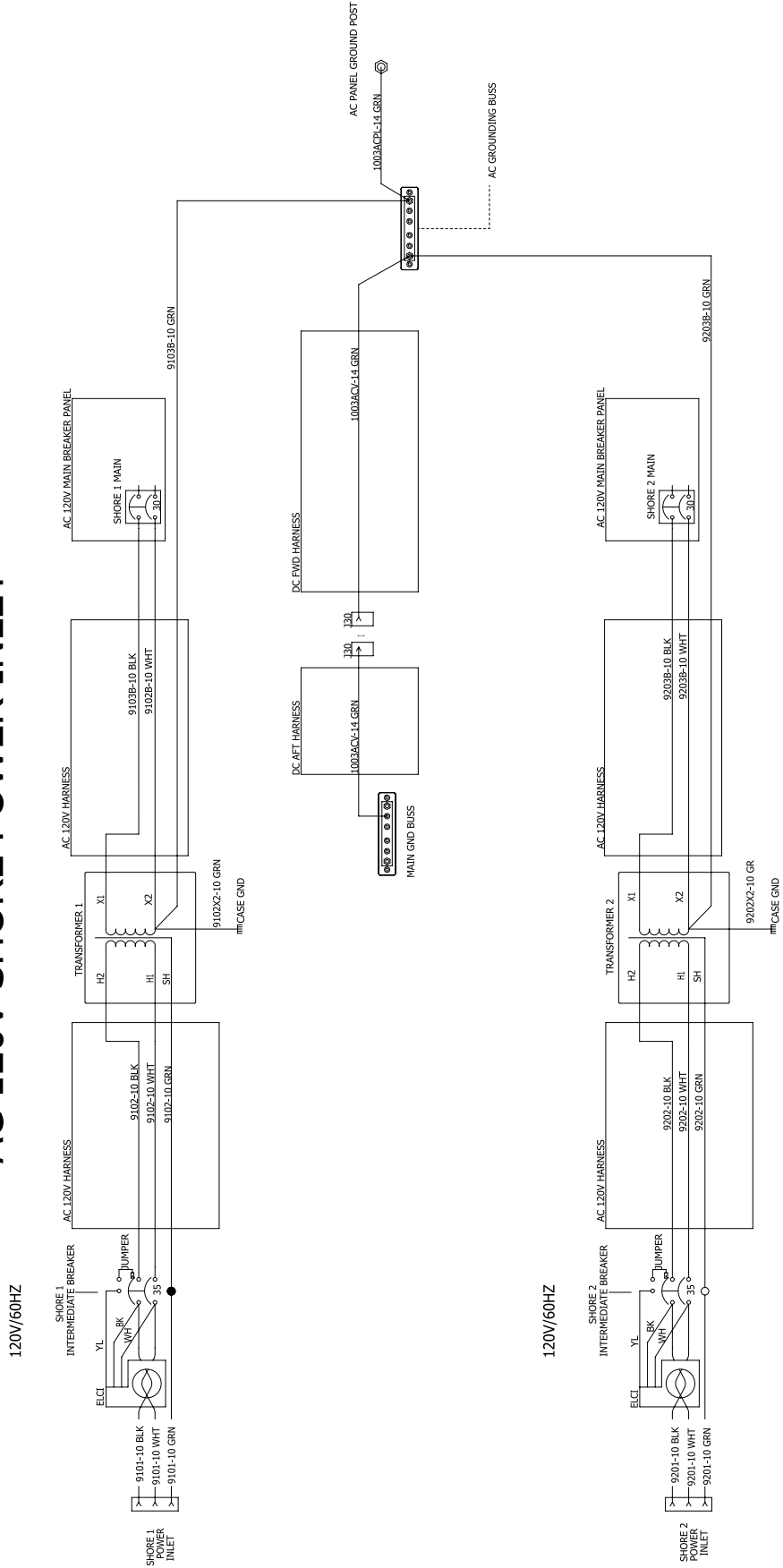

AC 120V Shore 1 Schematic
Figure 4.79.1

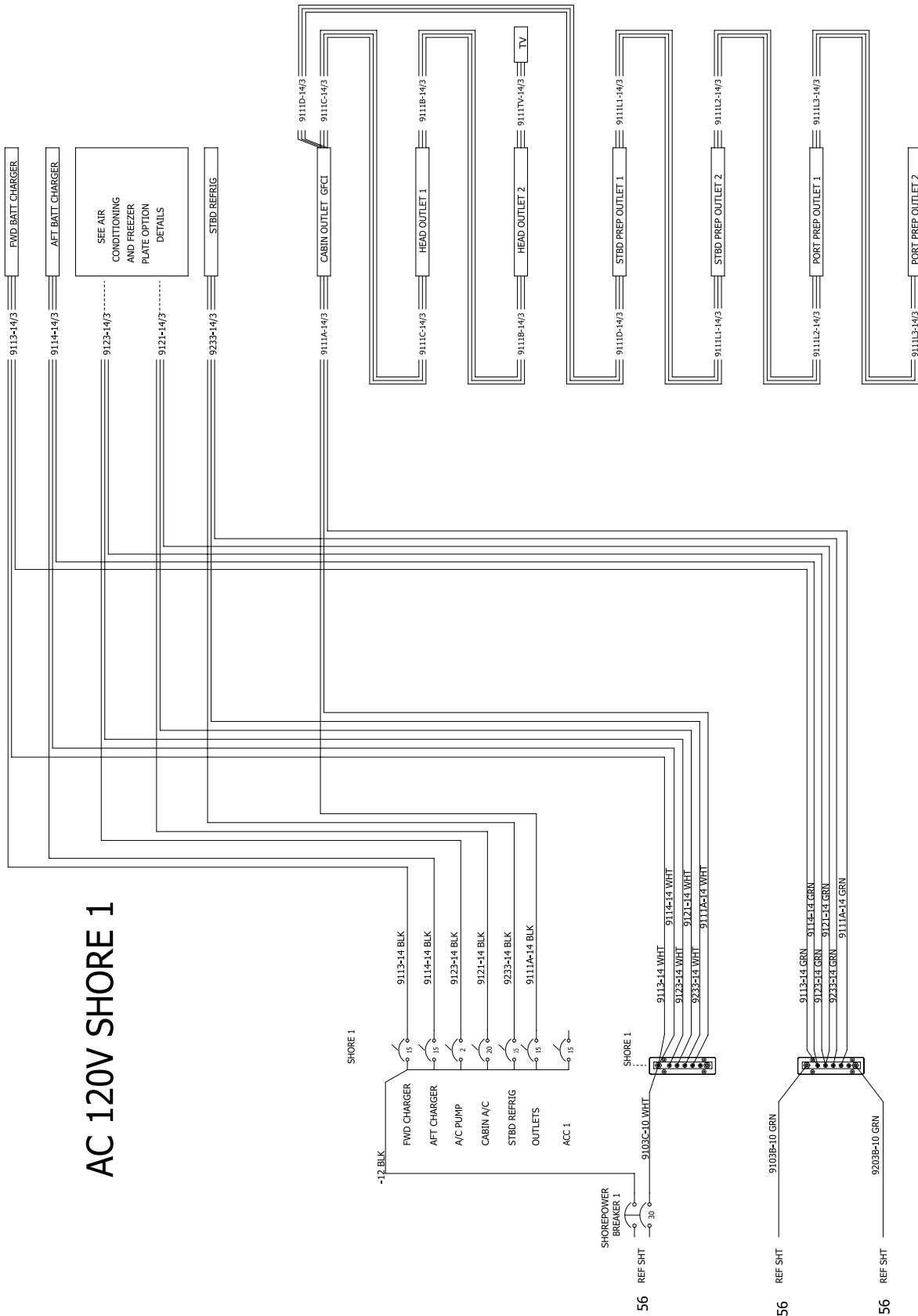

AC 120V Shore 2 Schematic
Figure 4.80.1

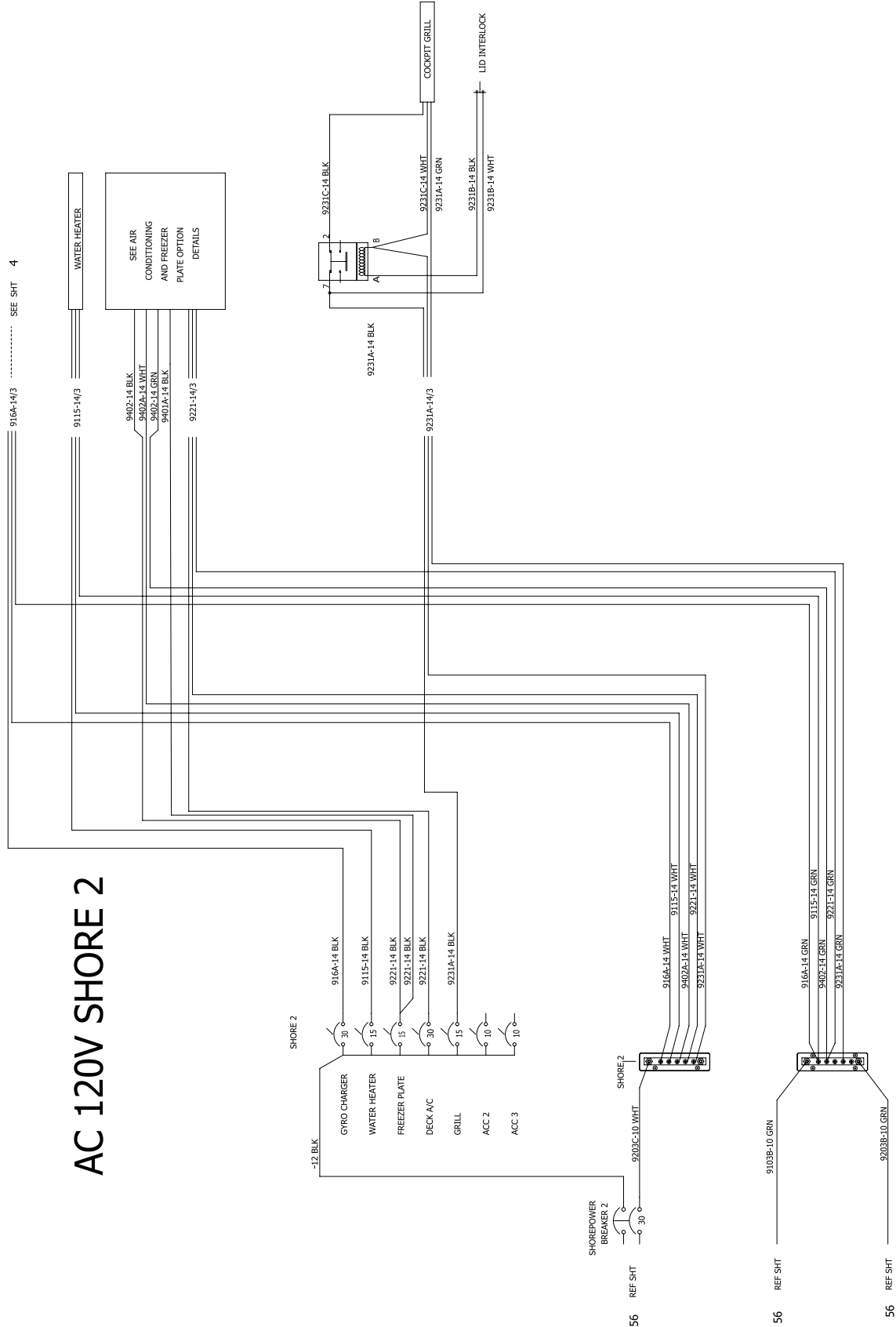

AC 120V Cabin AC
Figure 4.81.1

AC 120V CABIN AC

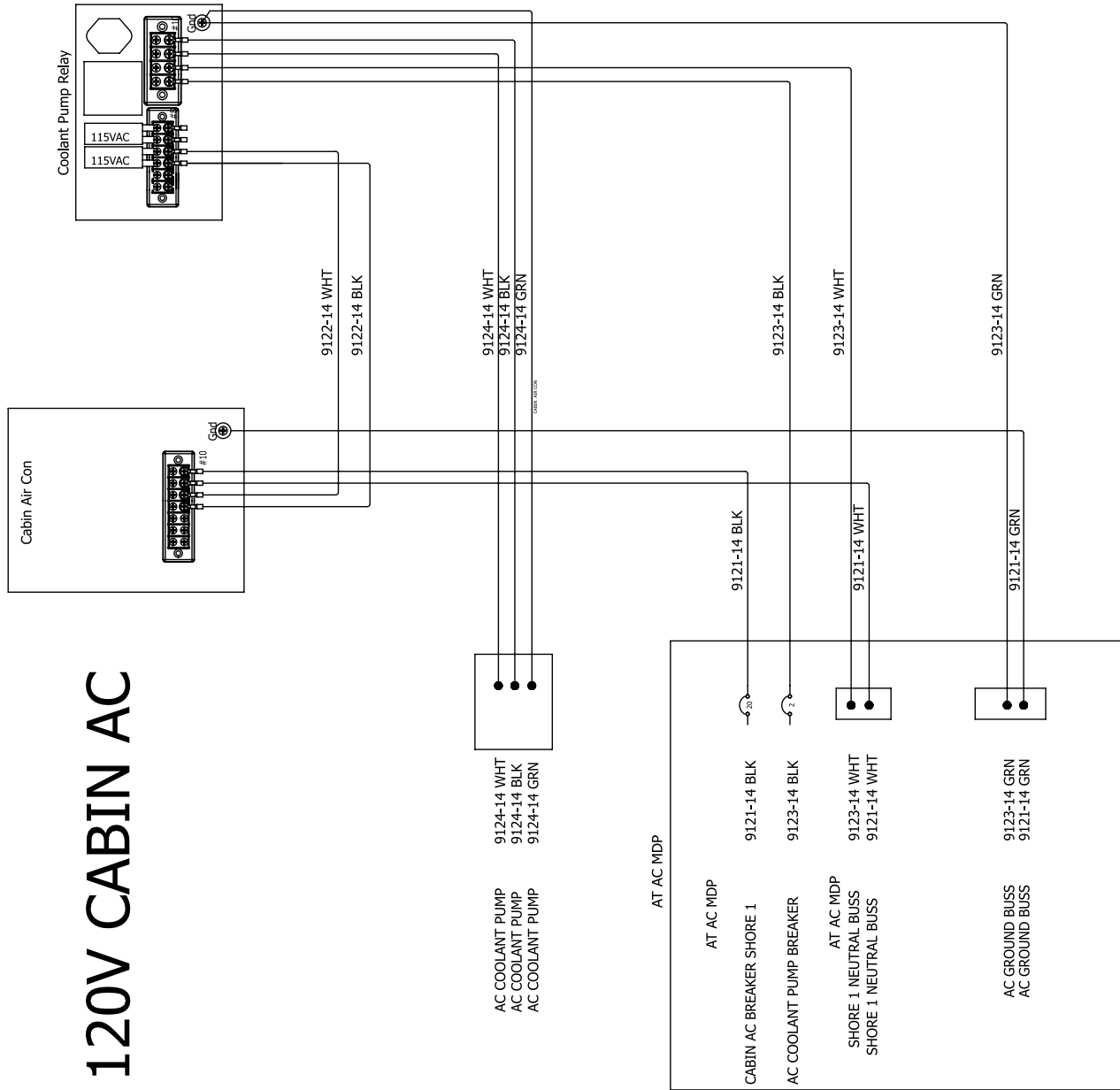

AC 120V Dual AC Schematic
Figure 4.82.1

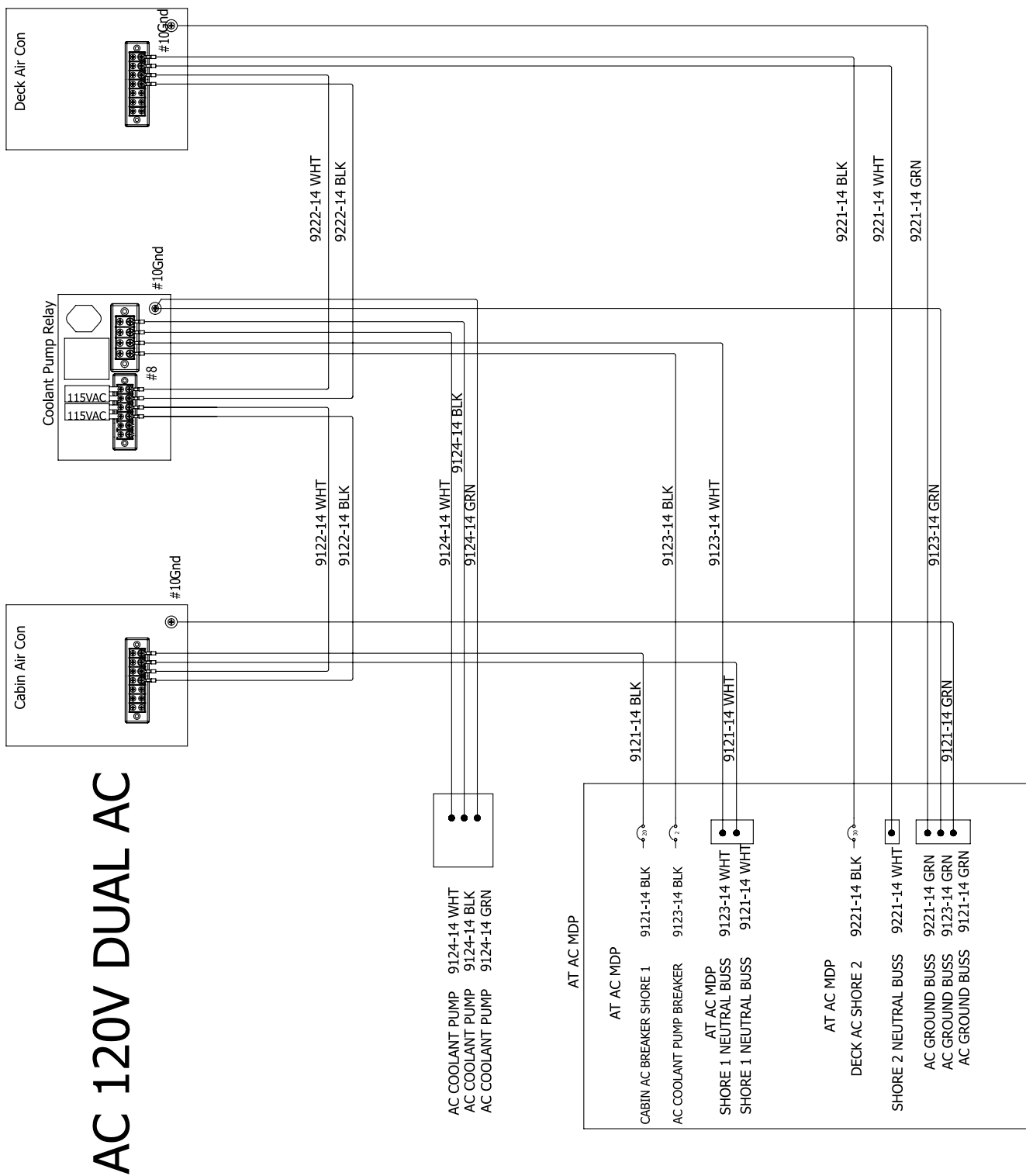

AC 120V Dual AC, Single freezer Plate Schematic
Figure 4.83.1

AC 120V DUAL AC, SINGLE FREEZER PLATE

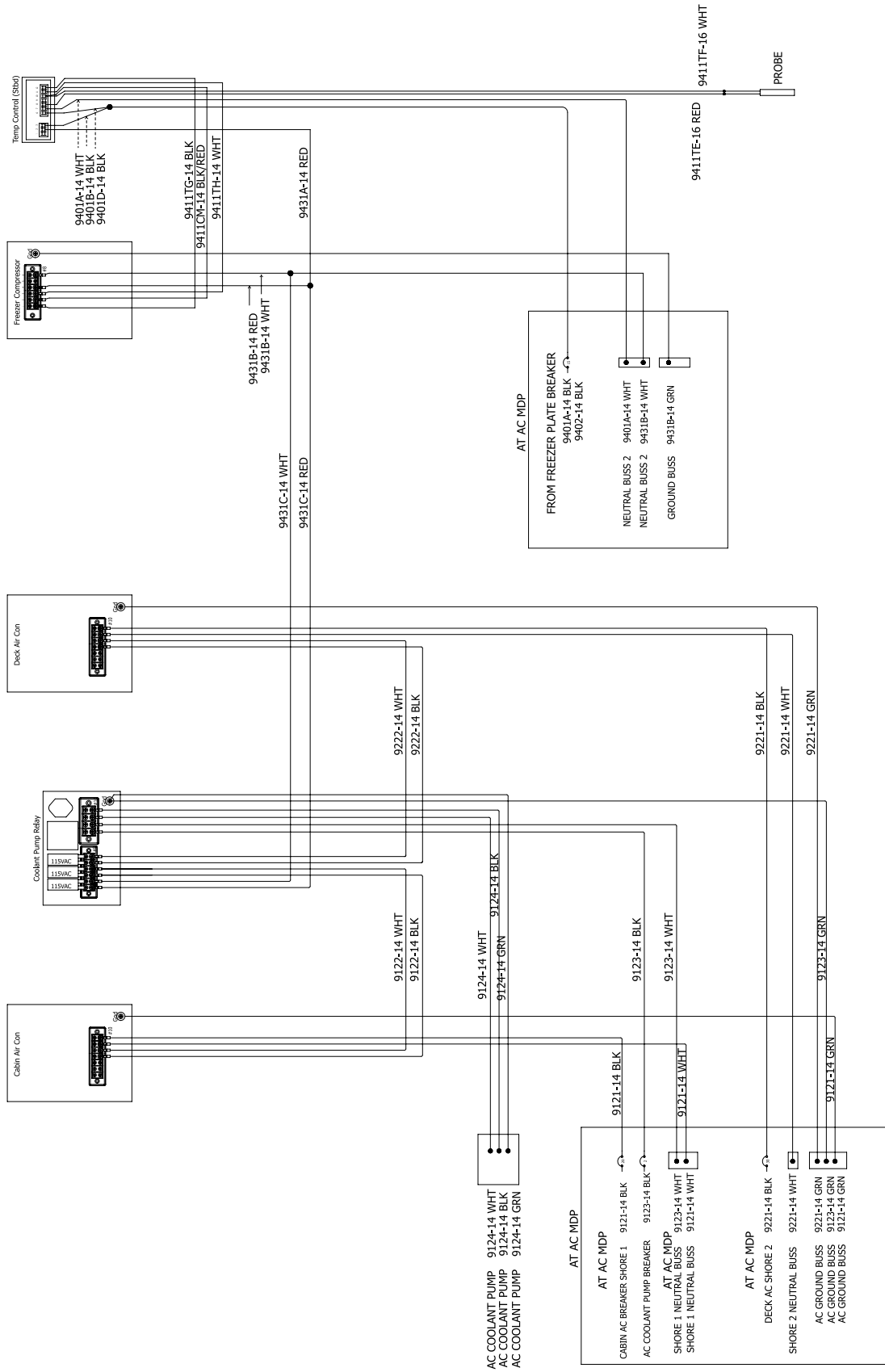

AC 120V Dual AC, Dual freezer Plate Schematic
Figure 4.84.1

AC 120V DUAL AC, DUAL FREEZER PLATE

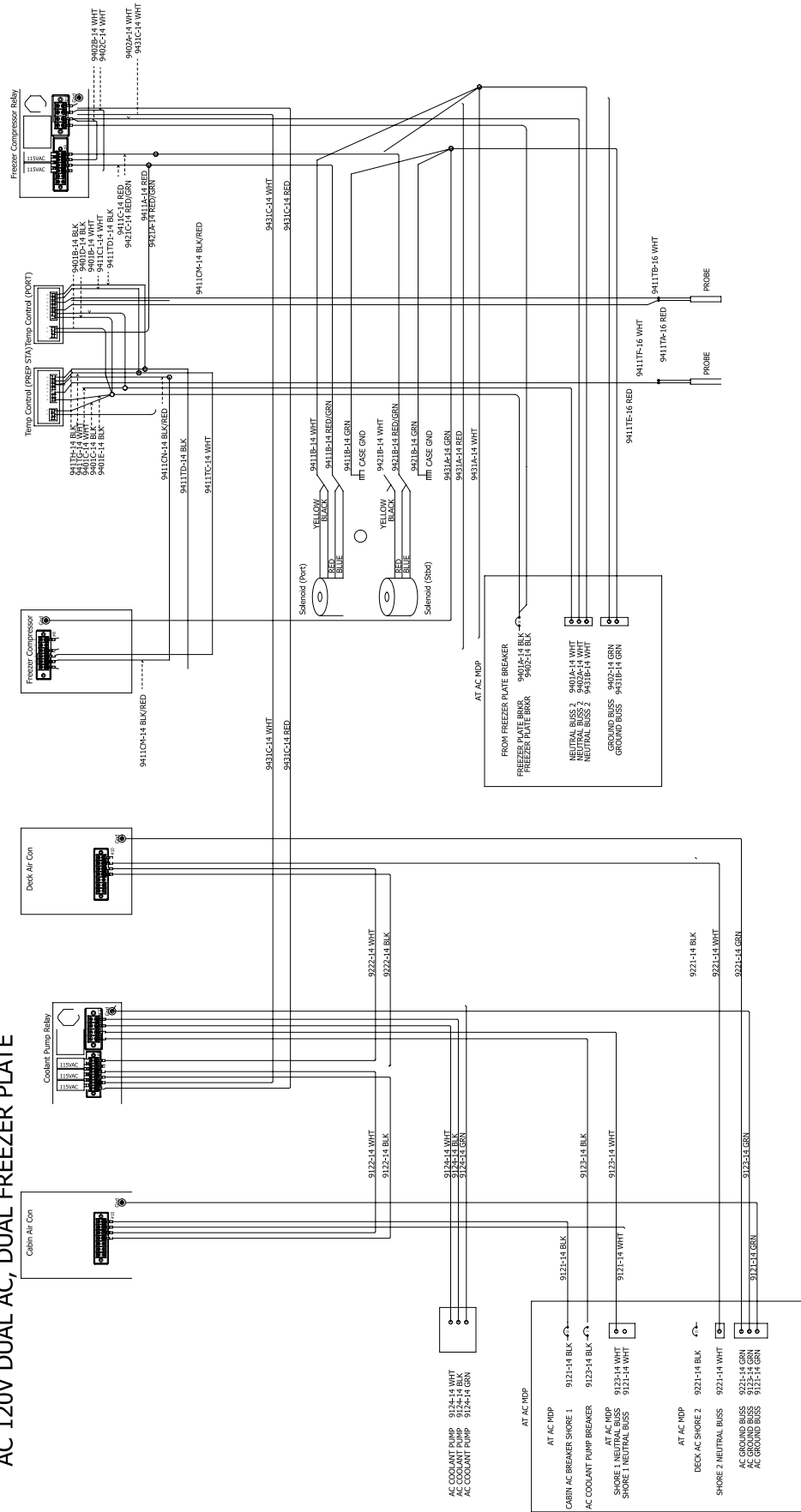

AC 230V Shore Power Inlet Schematic
Figure 4.85.1

AC 230V SHORE POWER INLET 230V/50HZ

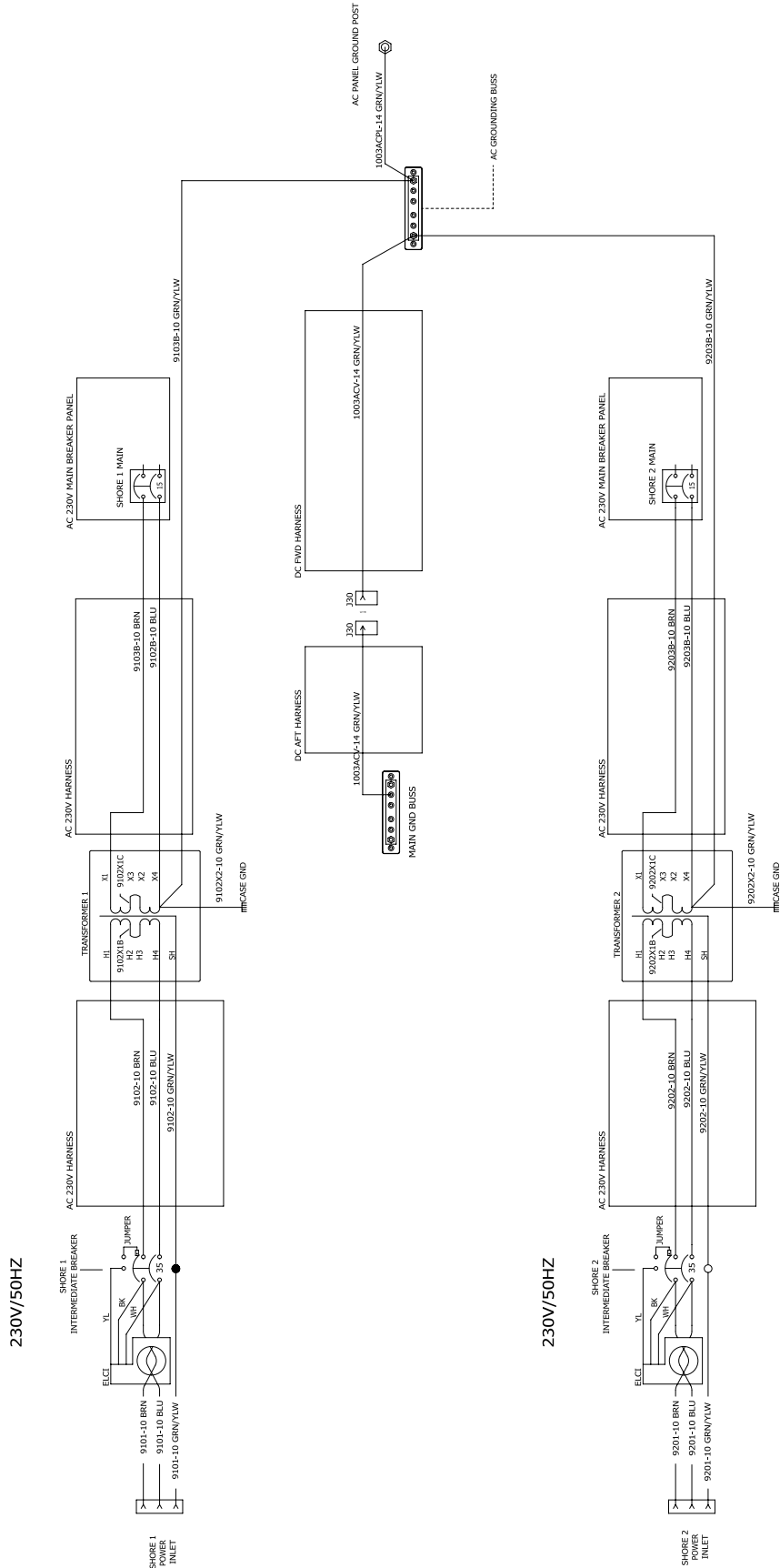

AC 230V Shore 1 Schematic
Figure 4.86.1

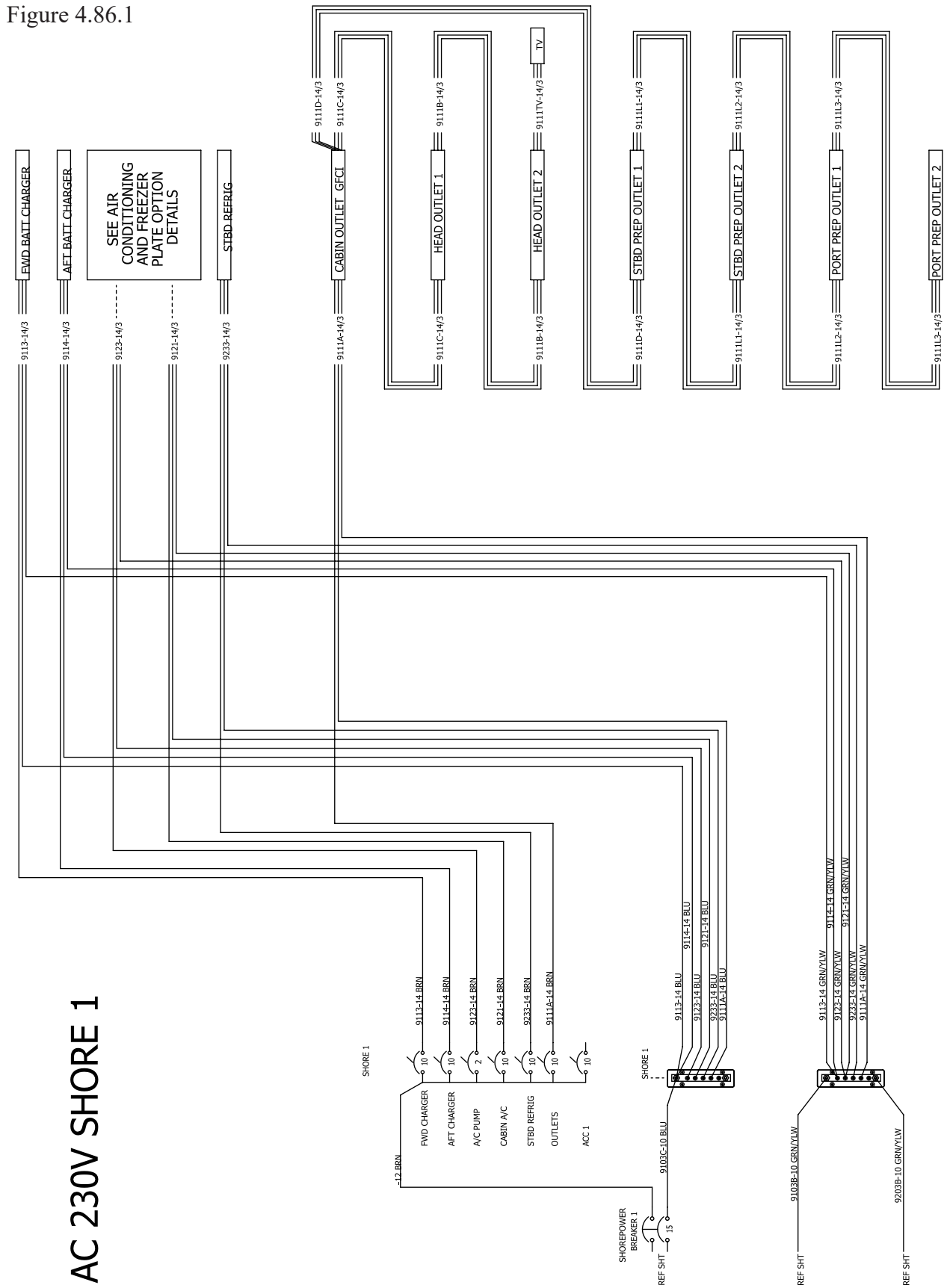

AC 230V Shore 2 Schematic
Figure 4.87.1

AC 230V SHORE 2

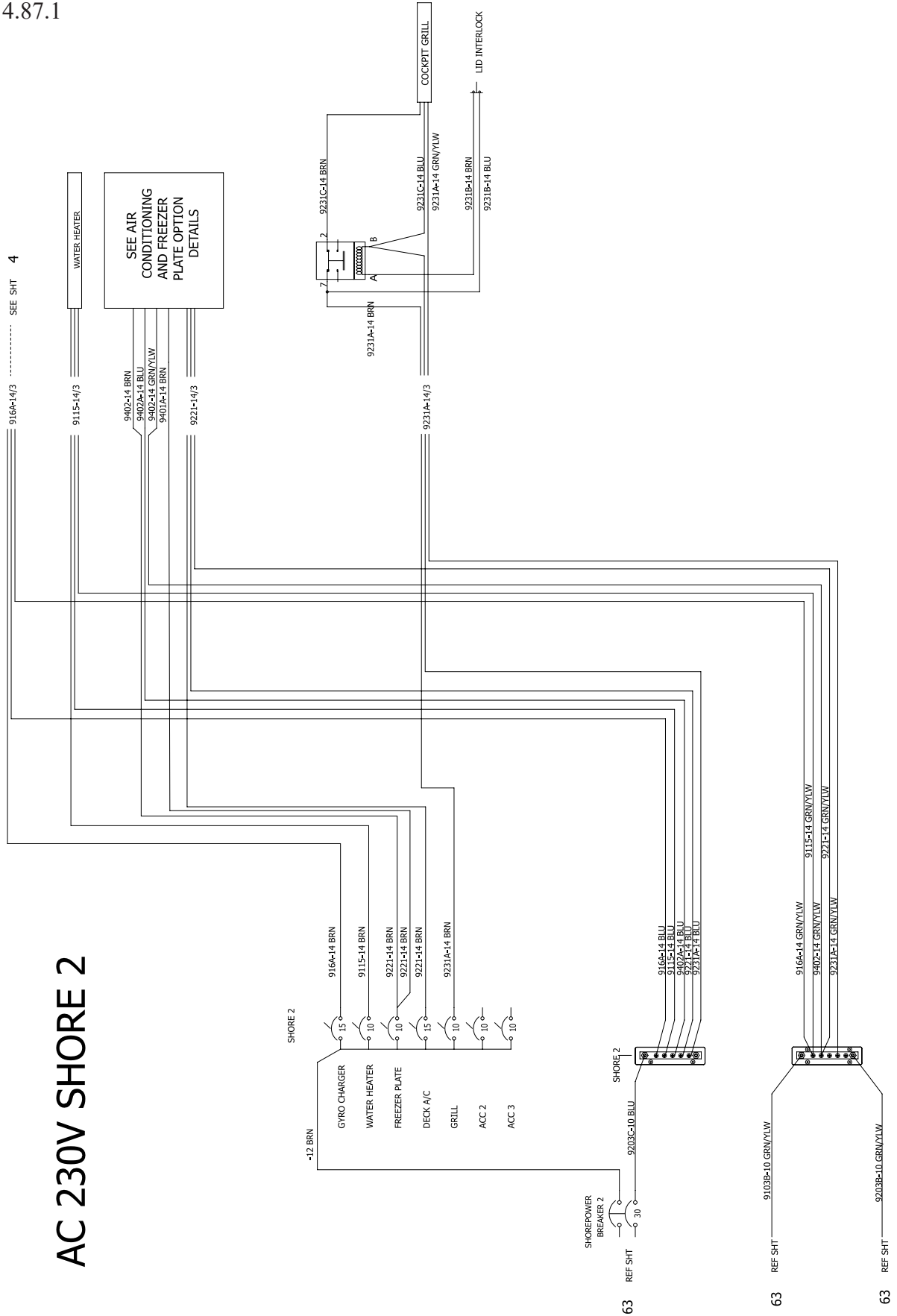

Cabin AC 230V Schematic
Figure 4.88.1

CABIN AC 230V

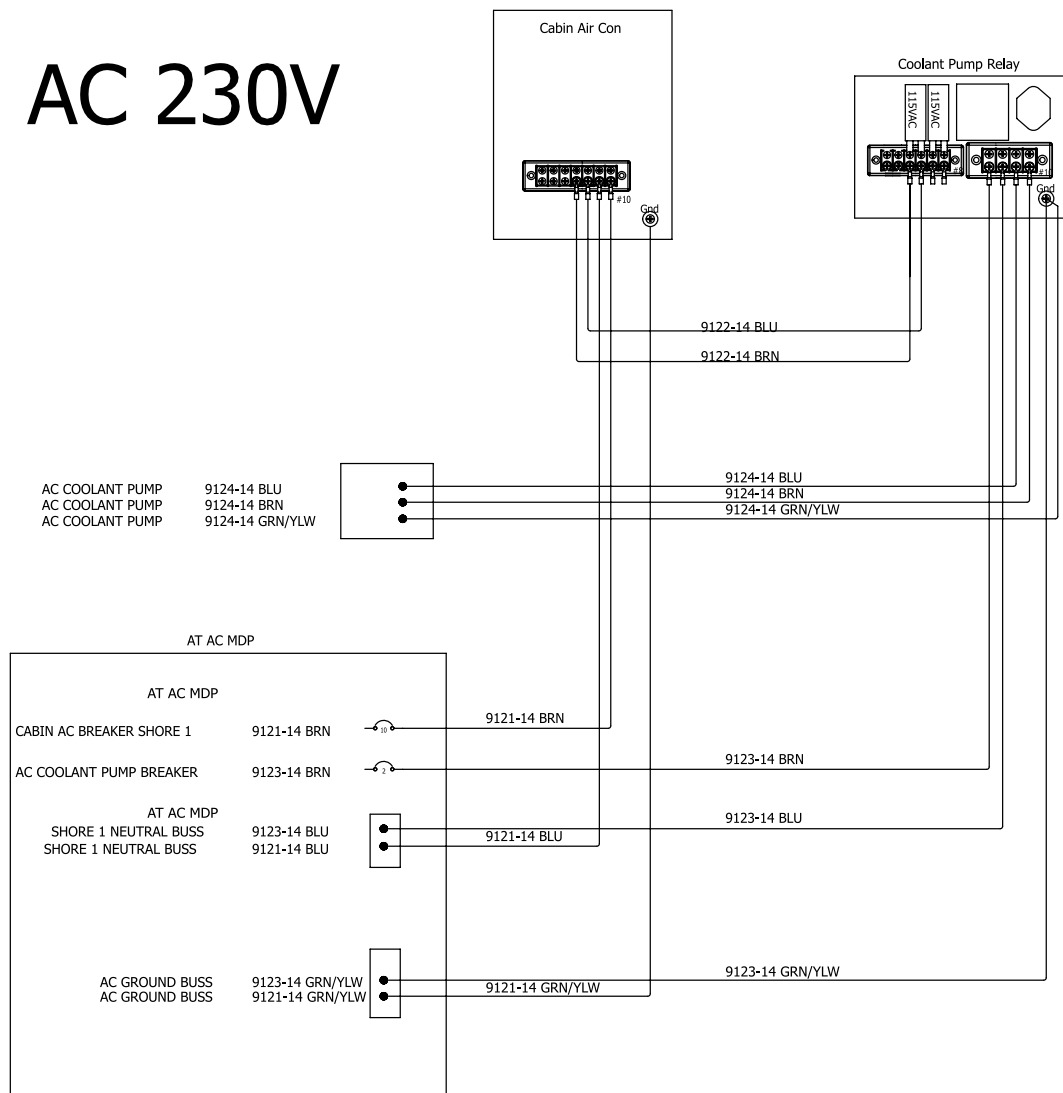

DUAL AC 230V Schematic
Figure 4.89.1

DUAL AC 230V

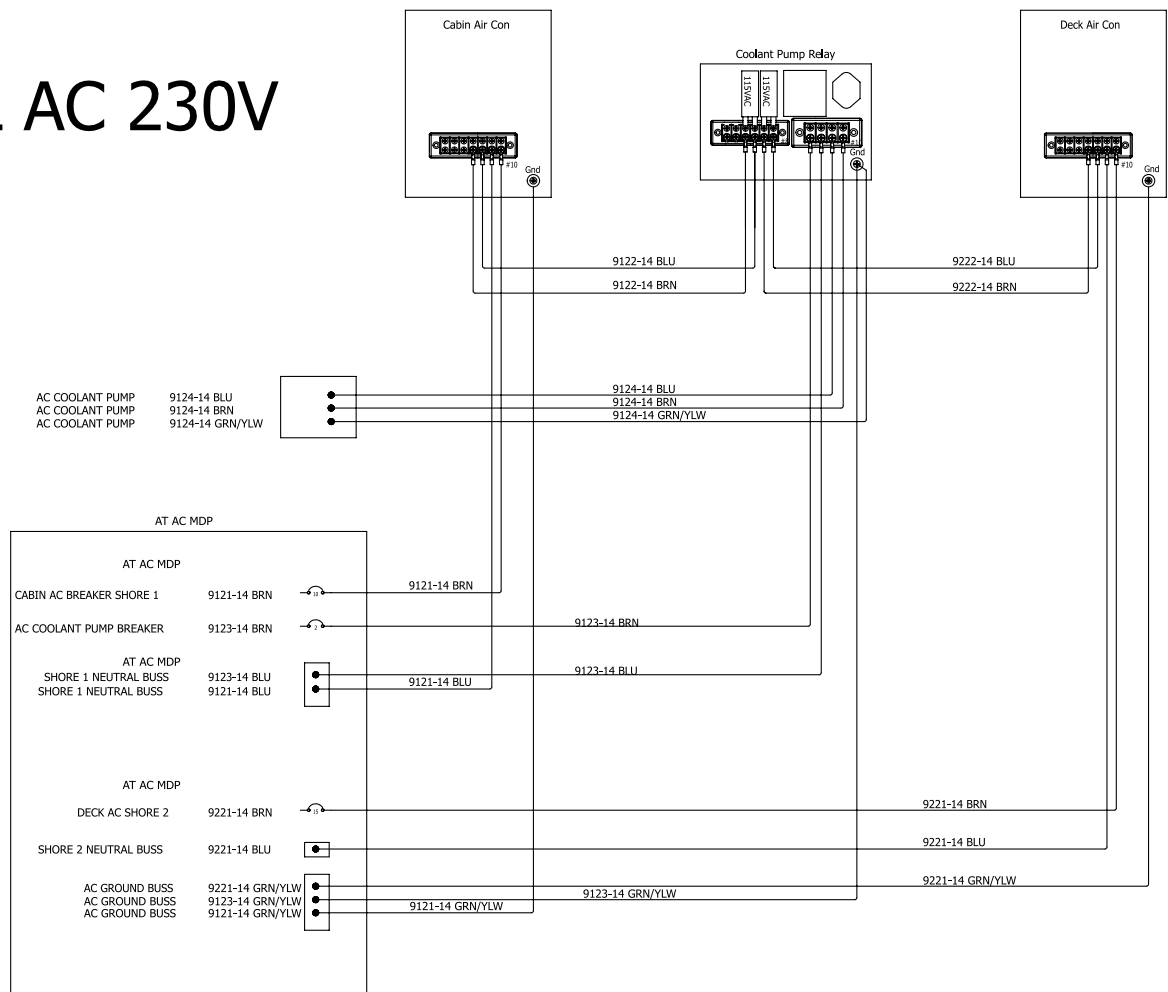

AC 230V/Dual Freezer Plate Schematic
Figure 4.90.1

DUAL AC 230V, DUAL FREEZER PLATE

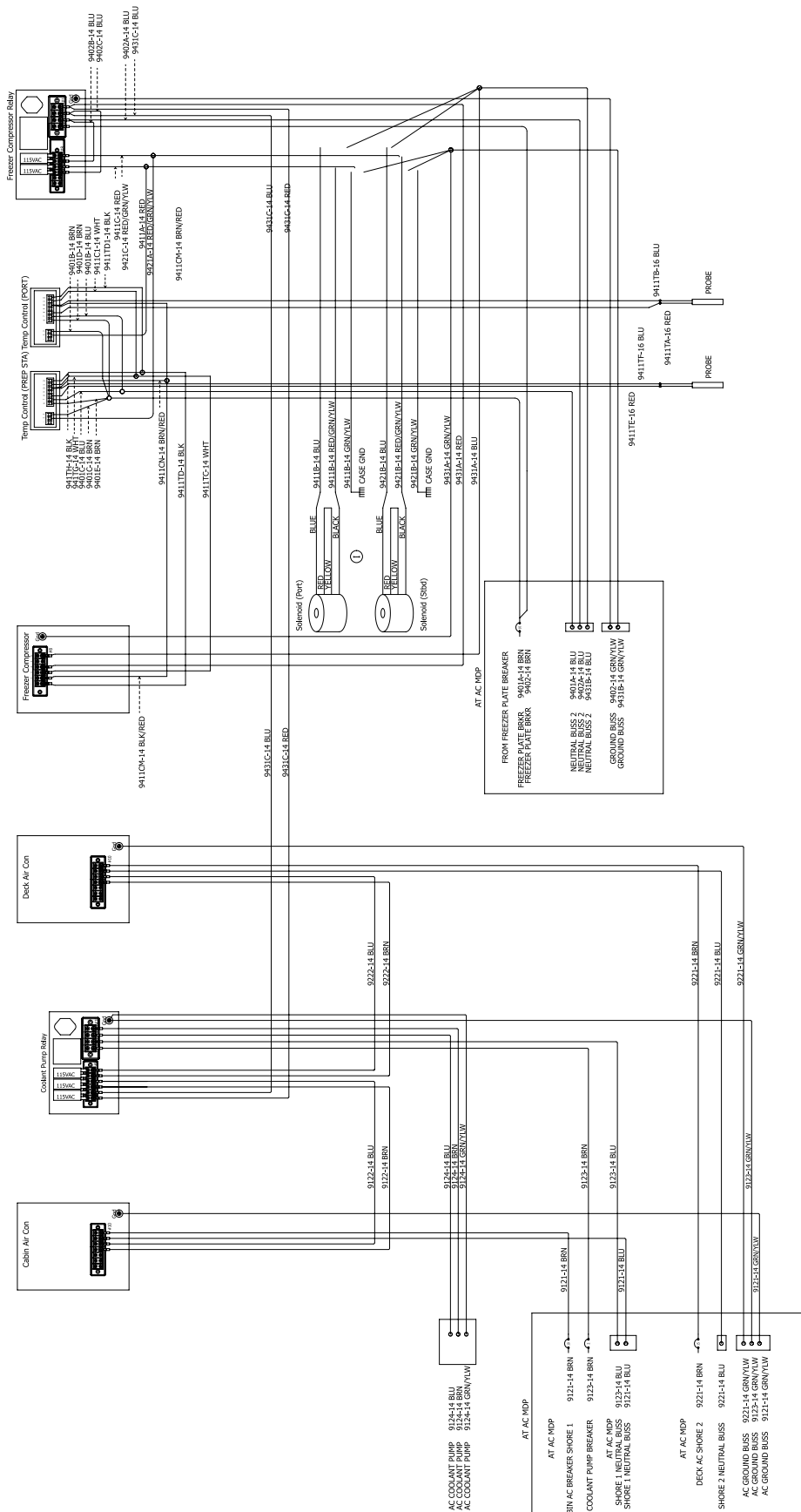

Battery Switch JPO Schematic Figure 4.91.1

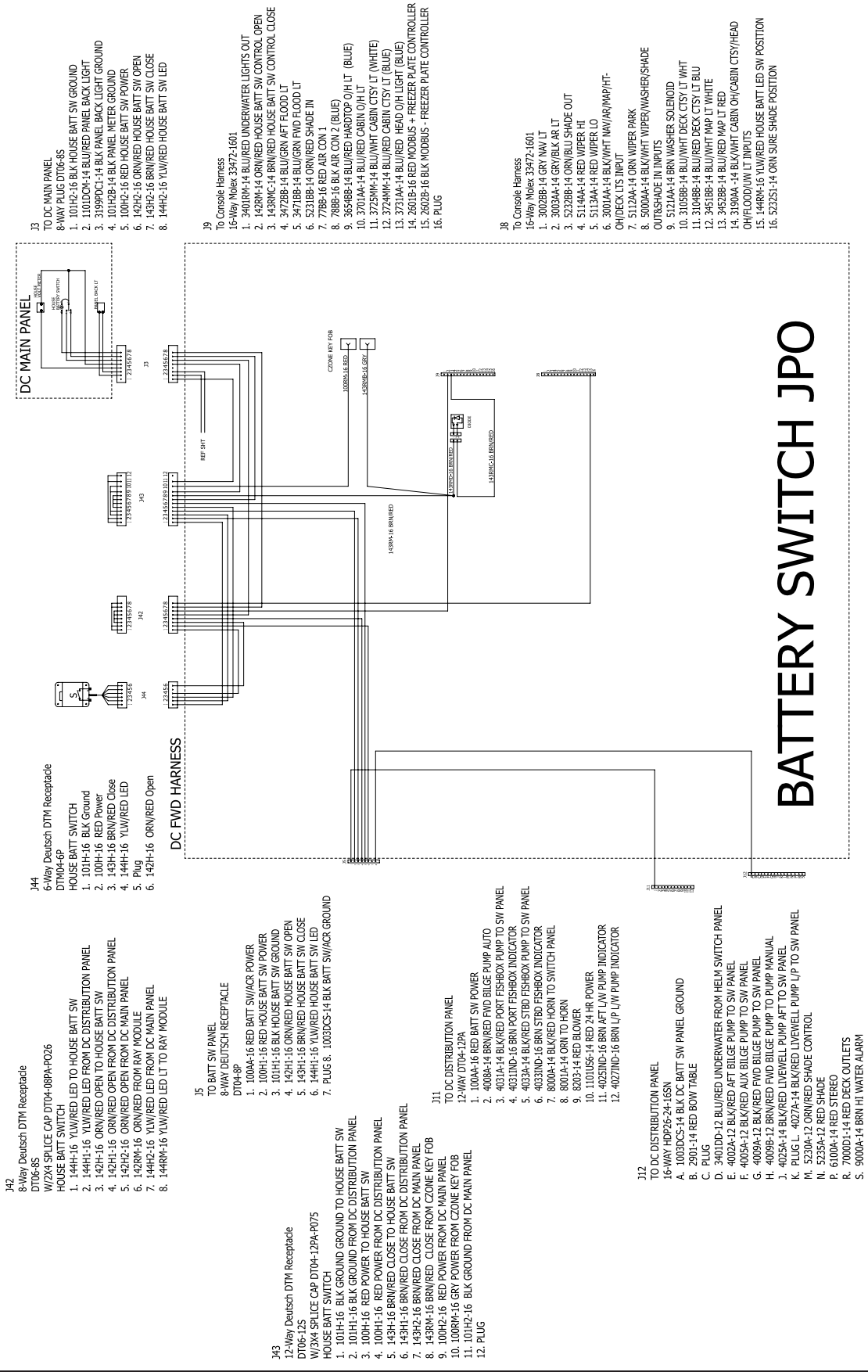

BATTERY SWITCH JPO

- J3**
TO DC MAIN PANEL
8-WAY PLUG DT06-8S
1. 101H2-16 BLK HOUSE BATT SW GROUND
2. 1101DCM-14 BLU/RED PANEL BACK LIGHT GROUND
3. 3199PDCI-14 BLK PANEL BACK LIGHT GROUND
4. 101H2B-14 BLK PANEL METER GROUND
5. 100H2-16 RED HOUSE BATT SW POWER
6. 142H2-16 ORN/RED HOUSE BATT SW OPEN
7. 143H2-16 BRN/RED HOUSE BATT SW CLOSE
8. 144H2-16 YLW/RED HOUSE BATT SW LED
- J9**
To Console Harness
16-Way Molex 33472-1601
1. 3401RN-14 BLU/RED UNDERWATER LIGHTS OUT
2. 421RN-14 BRN/RED HOUSE BATT SW CONTROL OPEN
3. 438YC-14 BRN/RED HOUSE BATT SW CONTROL CLOSE
4. 3472B8-14 BLU/GRN AFT FLOOD LT
5. 3471B8-14 BLU/GRN FWD FLOOD LT
6. 531B8-14 ORN/RED SHADE IN
7. 77B8-16 RED AIR CON 1
8. 78B8-16 BLK AIR CON 2 (BLUE)
9. 354B8-14 BLU/RED HARDTOP O/H LT (BLUE)
10. 3701AA-14 BLU/RED CABIN O/H LT
11. 3725MM-14 BLU/WHT CABIN CTSY LT (WHITE)
12. 3731AA-14 BLU/RED CABIN CTSY LT (BLUE)
13. 3731AA-14 BLU/RED HEAD O/H LIGHT (BLUE)
14. 2601B-16 RED MOBISUS + FREEZER PLATE CONTROLLER
15. 2602B-16 BLK MOBISUS - FREEZER PLATE CONTROLLER
16. PLUG
- J8**
To Console Harness
16-Way Molex 33472-1601
1. 3002B8-14 GRN NAV LT
2. 3003A4-14 GRN/BLK AR LT
3. 5232B8-14 ORN/BLU SHADE OUT
4. 5114A4-14 RED WIPER HI
5. 5113A4-14 RED WIPER LO
6. 3001A4-14 BLK/WHT NAV/AR/MAP/HT-OH/DECK LTS INPUT
7. 5112A4-14 ORN WIPER PARK
8. 5000A4-14 BLK/WHT WIPER/WASHER/SHADE OUT/SHADE IN INPUTS
9. 5121AA-14 BRN WASHER SOLENOID
10. 3105B8-14 BLU/WHT DECK CTSY LT WHT
11. 3104B8-14 BLU/RED DECK CTSY LT BLU
12. 3451B8-14 BLU/WHT MAP LT WHITE
13. 3452B8-14 BLU/RED MAP LT RED
14. 3190AA-14 BLK/WHT CABIN OH/CABIN CTSY/HEAD OH/FLOOD/UV LT INPUTS
15. 1448R-16 YLW/RED HOUSE BATT LED SW POSITION
16. 5232S1-14 ORN SURE SHADE POSITION
- J44**
6-Way Deutsch DTM Receptacle DT06-6P
HOUSE BATT SWITCH
1. 100H-16 BLK GROUND
2. 100H-16 RED Power
3. 143H-16 BRN/RED Close
4. 144H-16 YLW/RED LED
5. Plug
6. 142H-16 ORN/RED Open
- J5**
TO BATT SW PANEL
8-WAY DEUTSCH RECEPTACLE DT04-8P
1. 100AA-16 RED BATT SW/ACR POWER
2. 100H-16 RED HOUSE BATT SW POWER
3. 100H1-16 BLK HOUSE BATT SW GROUND
4. 142H1-16 BRN/RED HOUSE BATT SW OPEN
5. 143H1-16 BRN/RED HOUSE BATT SW CLOSE
6. 144H1-16 YLW/RED HOUSE BATT SW LED
7. PLUG 8. 1003DCS-14 BLK BATT SW/ACR GROUND
- J42**
8-Way Deutsch DTM Receptacle DT06-8S
W/2X4 SPLICE CAP DT04-08PA-PO26
HOUSE BATT SWITCH
1. 144H-16 YLW/RED LED TO HOUSE BATT SW
2. 144H1-16 YLW/RED LED FROM DC DISTRIBUTION PANEL
3. 142H-16 ORN/RED OPEN TO HOUSE BATT SW
4. 142H1-16 ORN/RED OPEN FROM DC DISTRIBUTION PANEL
5. 143H2-16 ORN/RED OPEN FROM DC MAIN PANEL
6. 142RM-16 ORN/RED FROM RAY MODULE
7. 144H2-16 YLW/RED LED FROM DC MAIN PANEL
8. 144RM-16 YLW/RED LED LT TO RAY MODULE
- J4**
12-Way Deutsch DTM Receptacle DT06-12S
W/3X4 SPLICE CAP DT04-12PA-P075
HOUSE BATT SWITCH
1. 101H-16 BLK GROUND TO HOUSE BATT SW
2. 101H1-16 BLK GROUND FROM DC DISTRIBUTION PANEL
3. 100H-16 RED POWER TO HOUSE BATT SW
4. 100H1-16 RED POWER FROM DC DISTRIBUTION PANEL
5. 143H-16 BRN/RED CLOSE TO HOUSE BATT SW
6. 143H1-16 BRN/RED CLOSE FROM DC DISTRIBUTION PANEL
7. 143H2-16 BRN/RED CLOSE FROM DC MAIN PANEL
8. 143RM-16 BRN/RED CLOSE FROM CONSOLE NET FOB
9. 100R2-16 GRN POWER FROM DC MAIN PANEL
10. 100RN-16 GRN POWER FROM CONSOLE NET FOB
11. 101H2-16 BLK GROUND FROM DC MAIN PANEL
12. PLUG
- J11**
TO DC DISTRIBUTION PANEL
12-WAY DT04-12PA
1. 100AA-16 RED BATT SW POWER
2. 4008A-14 BRN/RED FWD BILGE PUMP AUTO
3. 4031A-14 BLK/RED PORT FISHBOX PUMP TO SW PANEL
4. 4031ND-16 BRN PORT FISHBOX INDICATOR
5. 4033A-14 BLK/RED STB9 FISHBOX PUMP TO SW PANEL
6. 4033ND-16 BRN STB9 FISHBOX INDICATOR
8. 8001A-14 ORN TO HORN
9. 8203-14 RED BLOWER
10. 1101SE-14 RED 24-HR POWER
11. 4025ND-16 BRN AFT LW PUMP INDICATOR
12. 4027ND-16 BRN LP LW PUMP INDICATOR
- J12**
TO DC DISTRIBUTION PANEL
16-WAY HD26-24-16SN
A. 1003DCS-14 BLK DC BATT SW PANEL GROUND
B. 2901-14 RED BOW TABLE
C. PLUG
D. 3401DD-12 BLU/RED UNDERWATER FROM HELM SWITCH PANEL
E. 4002A-12 BLK/RED AFT BILGE PUMP TO SW PANEL
F. 4005A-12 BLK/RED AUX BILGE PUMP TO SW PANEL
G. 4009A-12 BLK/RED FWD BILGE PUMP TO SW PANEL
H. 4009B-12 BRN/RED FWD BILGE PUMP TO PUMP MANUAL
J. 4025A-14 BLK/RED LIVEWELL PUMP AFT TO SW PANEL
K. PLUG L. 4027A-14 BLK/RED LIVEWELL PUMP LP TO SW PANEL
M. 5230A-12 ORN/RED SHADE CONTROL
N. 5235A-12 RED SHADE
P. 6100A-14 RED STEREO
R. 7000D1-14 RED DECK OUTLETS
S. 9000A-14 BRN H1 WATER ALARM

Battery switch Schematic
Figure 4.92.1

BATTERY SWITCH STD

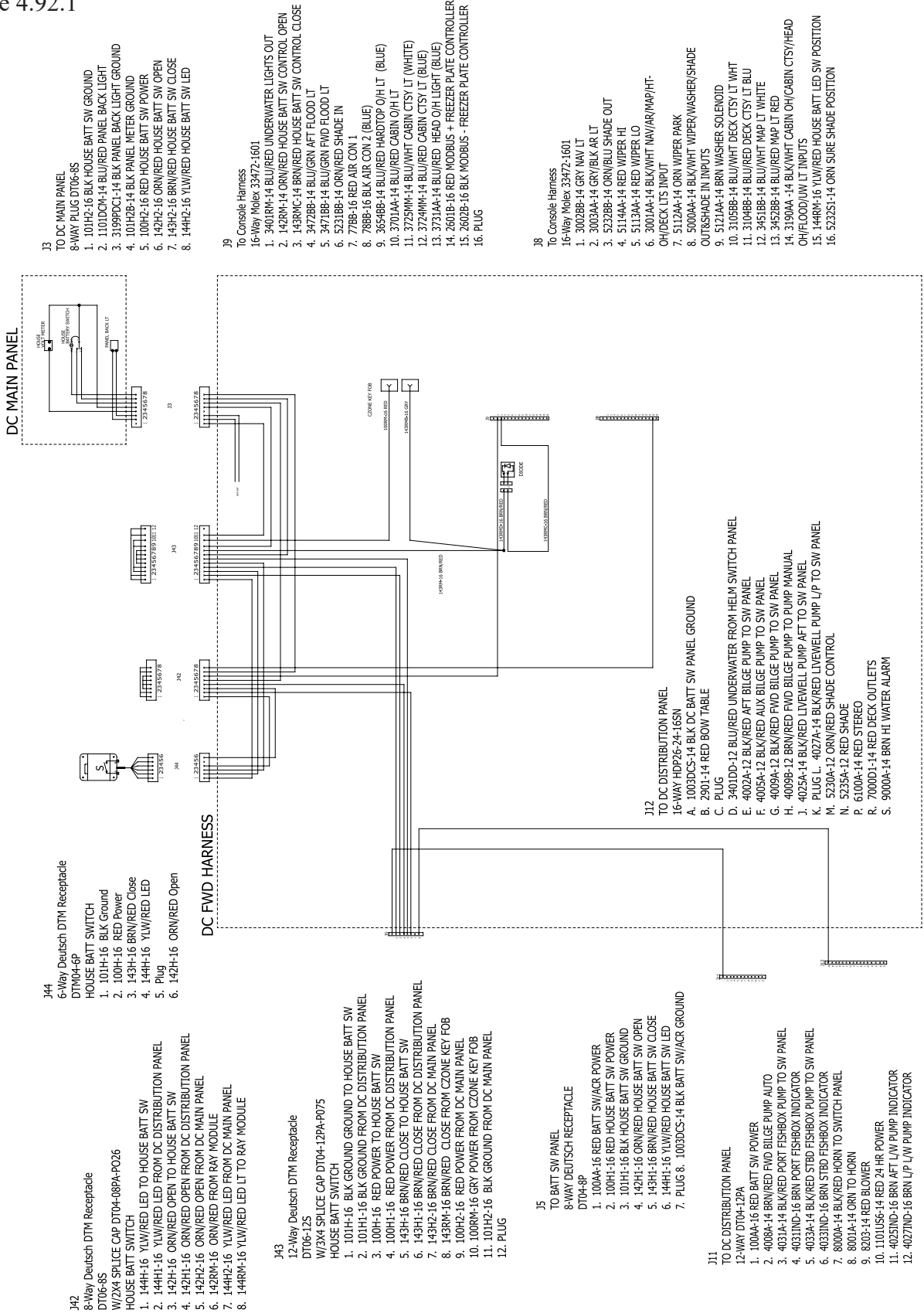

- 13. TO DC MAIN PANEL
 - 8-WAY PLUG DT06-8S
 - 1. 101H-16 BLK HOUSE BATT SW GROUND
 - 2. 1101DCH-14 BLU/RED PANEL BACK LIGHT
 - 3. 3199PDC1-14 BLK PANEL METER GROUND
 - 4. 101H2B-14 BLK PANEL METER GROUND
 - 5. 100H2-16 RED HOUSE BATT SW OPEN
 - 6. 142H-16 ORN/RED HOUSE BATT SW OPEN
 - 7. 142H-16 ORN/RED HOUSE BATT SW CLOSE
 - 8. 144H2-16 YLW/RED HOUSE BATT SW LED
- 16-Way Molex 33472-1601
 - 1. 3401RM-14 BLU/RED UNDERWATER LIGHTS OUT
 - 2. 142RM-14 ORN/RED HOUSE BATT SW CONTROL OPEN
 - 3. 143RMC-14 BRN/RED HOUSE BATT SW CONTROL CLOSE
 - 4. 3472BB-14 BLU/GRN AFT FLOOD LT
 - 5. 3471BB-14 BLU/GRN FWD FLOOD LT
 - 6. 5231BB-14 ORN/RED SHADE IN
 - 7. 778B-16 RED AIR CON 1
 - 8. 788B-16 BLK AIR CON 2 (BLUE)
 - 9. 3654BB-14 BLU/RED HARDTOP O/H LT (BLUE)
 - 10. 3701AA-14 BLU/RED CABIN O/H LT
 - 11. 3725MM-14 BLU/WHIT CABIN CTSY LT (WHITE)
 - 12. 3724MM-14 BLU/RED CABIN CTSY LT (BLUE)
 - 13. 3731AA-14 BLU/RED HEAD O/H LIGHT (BLUE)
 - 14. 2601B-16 RED MODBUS + FREEZER PLATE CONTROLLER
 - 15. 2602B-16 BLK MODBUS - FREEZER PLATE CONTROLLER
 - 16. PLUG
- To Console Harness
 - 16-Way Molex 33472-1601
 - 1. 3002BB-14 GRN NAV LT
 - 2. 3003AA-14 GRN/BLK AR LT
 - 3. 5232BB-14 ORN/BLU SHADE OUT
 - 4. 5114AA-14 RED WIPER HI
 - 5. 5113AA-14 RED WIPER LO
 - 6. 3001AA-14 BLK/WHIT NAV/AR/WIP/H/OH/DECK LTS INPUT
 - 7. 5112AA-14 ORN WIPER PARK
 - 8. 5000AA-14 BLK/WHIT WIPER/WASHER/SHADE OUT/RSHADE IN INPUTS
 - 9. 5121AA-14 BRN WASHER SOLENOID
 - 10. 3105BB-14 BLU/WHIT DECK CTSY LT WHT
 - 11. 3104BB-14 BLU/RED DECK CTSY LT BLU
 - 12. 3451BB-14 BLU/WHIT MAP LT WHITE
 - 13. 3452BB-14 BLU/RED MAP LT RED
 - 14. 3190AA-14 BLK/WHIT CABIN O/H/CABIN CTSY/HEAD O/H/FLOOD/J/W LT INPUTS
 - 15. 144RM-16 YLW/RED HOUSE BATT LED SW POSITION
 - 16. 5232S1-14 ORN SURE SHADE POSITION

- J44. 6-Way Deutsch DTM Receptacle
 - DTM04-6P
 - HOUSE BATT SWITCH
 - 1. 101H-16 BLK Ground
 - 2. 100H-16 RED Power
 - 3. 143H-16 BRN/RED Close
 - 4. 144H-16 YLW/RED LED
 - 5. Plug
 - 6. 142H-16 ORN/RED Open
- J43. 12-Way Deutsch DTM Receptacle
 - DT06-12S
 - W/3X4 SPLICE CAP DT04-12PA-P075
 - HOUSE BATT SWITCH
 - 1. 101H-16 BLK GROUND FROM DC DISTRIBUTION PANEL
 - 2. 101H1-16 BLK GROUND FROM DC DISTRIBUTION PANEL
 - 3. 100H-16 RED POWER TO HOUSE BATT SW
 - 4. 100H1-16 RED POWER FROM DC DISTRIBUTION PANEL
 - 5. 143H-16 BRN/RED CLOSE TO HOUSE BATT SW
 - 6. 143H1-16 BRN/RED CLOSE FROM DC DISTRIBUTION PANEL
 - 7. 143H2-16 BRN/RED CLOSE FROM DC MAIN PANEL
 - 8. 143RM-16 BRN/RED CLOSE FROM CZONE KEY FOB
 - 9. 100H2-16 RED POWER FROM DC MAIN PANEL
 - 10. 100RM-16 GRN POWER FROM CZONE KEY FOB
 - 11. 101H2-16 BLK GROUND FROM DC MAIN PANEL
 - 12. PLUG
- J5. TO BATT SW PANEL
 - 8-WAY DEUTSCH RECEPTACLE
 - DT04-8P
 - 1. 100AA-16 RED BATT SW/ACR POWER
 - 2. 100H1-16 RED HOUSE BATT SW POWER
 - 3. 101H1-16 BLK HOUSE BATT SW GROUND
 - 4. 142H1-16 ORN/RED HOUSE BATT SW OPEN
 - 5. 143H1-16 BRN/RED HOUSE BATT SW CLOSE
 - 6. 144H1-16 YLW/RED HOUSE BATT SW LED
 - 7. PLUG 8. 1003DCS-14 BLK BATT SW/ACR GROUND
- J11. TO DC DISTRIBUTION PANEL
 - 12-WAY DT04-12PA
 - 1. 100AA-16 RED BATT SW POWER
 - 2. 4008A-14 BRN/RED FWD BILGE PUMP AUTO
 - 3. 4008A-14 BLK/RED PORT FISHBOX PUMP TO SW PANEL
 - 4. 4031ND-16 BRN PORT FISHBOX INDICATOR
 - 5. 4033A-14 BLK/RED STBD FISHBOX PUMP TO SW PANEL
 - 6. 4033ND-16 BRN STBD FISHBOX INDICATOR
 - 7. 8001A-14 BLK/RED HORN TO SWITCH PANEL
 - 8. 8001A-14 ORN TO HORN
 - 9. 8203-14 RED BLOWER
 - 10. 1101US6-14 RED 24 HR POWER
 - 11. 4025ND-16 BRN AFT L/W PUMP INDICATOR
 - 12. 4027ND-16 BRN L/P L/W PUMP INDICATOR
- J12. TO DC DISTRIBUTION PANEL
 - 16-WAY HD26-24-16SN
 - A. 1003DCS-14 BLK DC BATT SW PANEL GROUND
 - B. 2901-14 RED BOW TABLE
 - C. PLUG
 - D. 3401DD-12 BLU/RED UNDERWATER FROM HELM SWITCH PANEL
 - E. 4002A-12 BLK/RED AFT BILGE PUMP TO SW PANEL
 - F. 4005A-12 BLK/RED AUX BILGE PUMP TO SW PANEL
 - G. 4009A-12 BLK/RED FWD BILGE PUMP TO SW PANEL
 - H. 4009B-12 BRN/RED FWD BILGE PUMP TO PUMP MANUAL
 - J. 4025A-14 BLK/RED LIVEWELL PUMP AFT TO SW PANEL
 - K. PLUG L. 4027A-14 BLK/RED LIVEWELL PUMP LP TO SW PANEL
 - M. 5230A-12 ORN/RED SHADE CONTROL
 - N. 5230A-12 RED SHADE
 - P. 6100A-14 RED STEREO
 - R. 7000D1-14 RED DECK OUTLETS
 - S. 9000A-14 BRN HI WATER ALARM

Generator - 120V/60HZ (Domestic) Schematic
Figure 4.93.1

GENERATOR - 120V/60HZ (DOMESTIC)

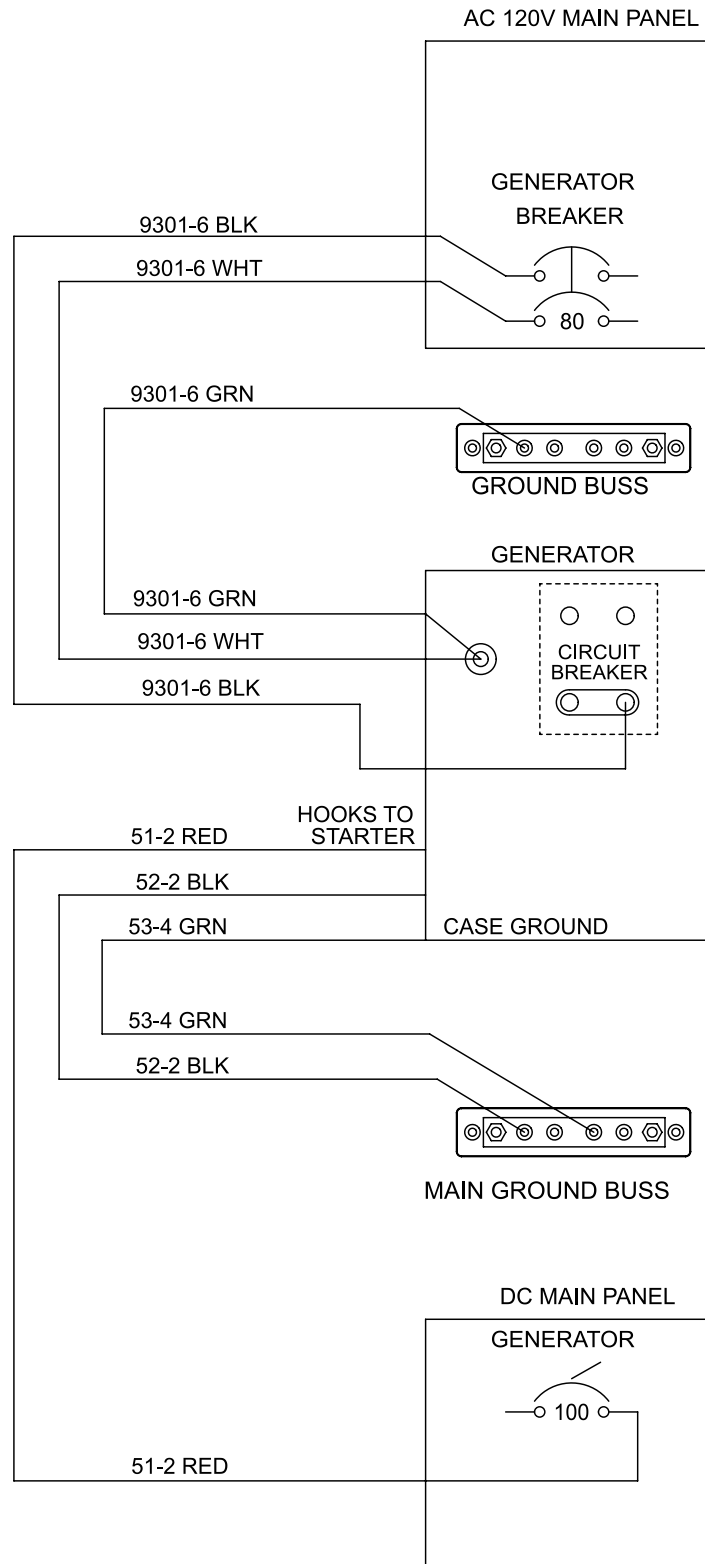

Generator - 230V/50HZ (EURO) Schematic
Figure 4.94.1

GENERATOR - 230V/50HZ (EURO)

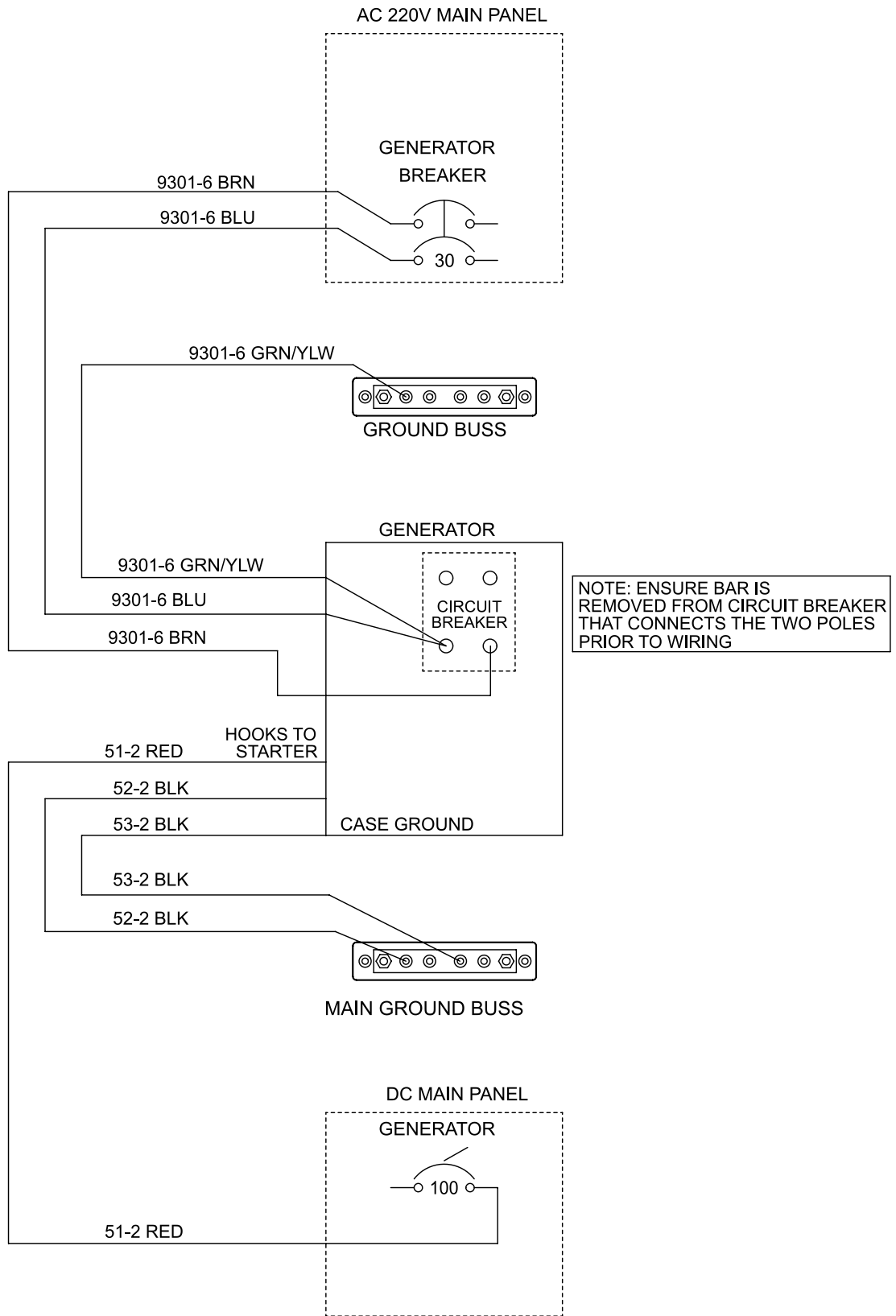

AC 120V MDP Schematic
Figure 4.95.1

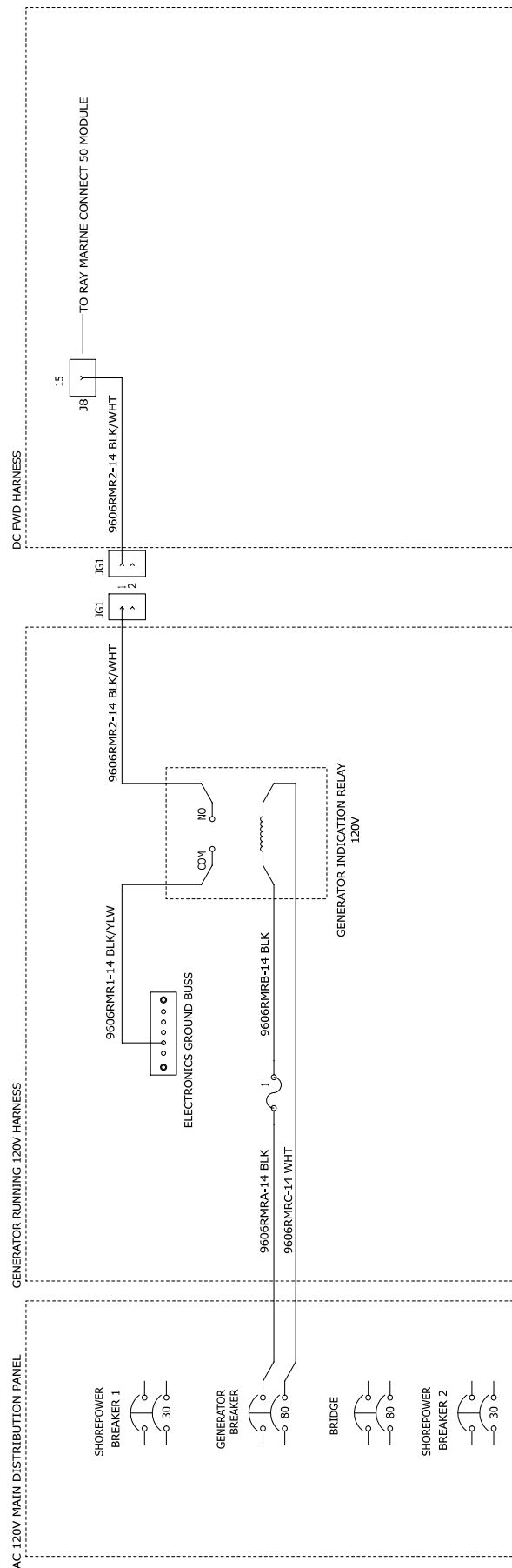

AC 220V MDP Schematic
Figure 4.96.1

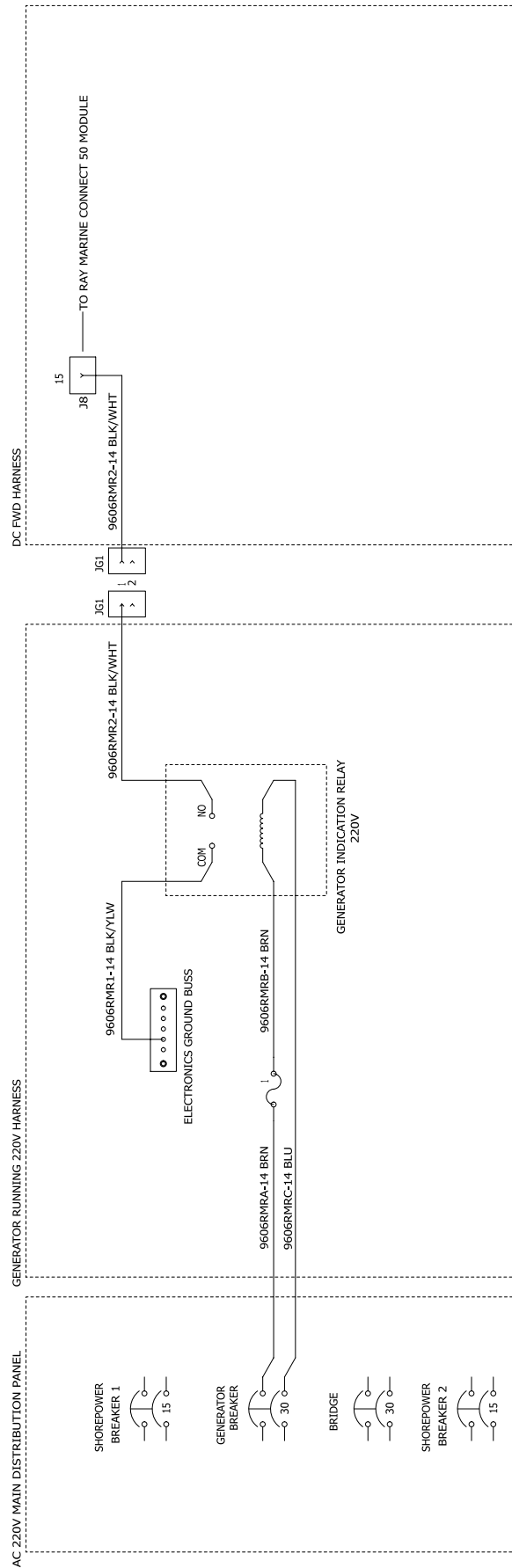

AC 230V Shore 2 Schematic
Figure 4.97.1

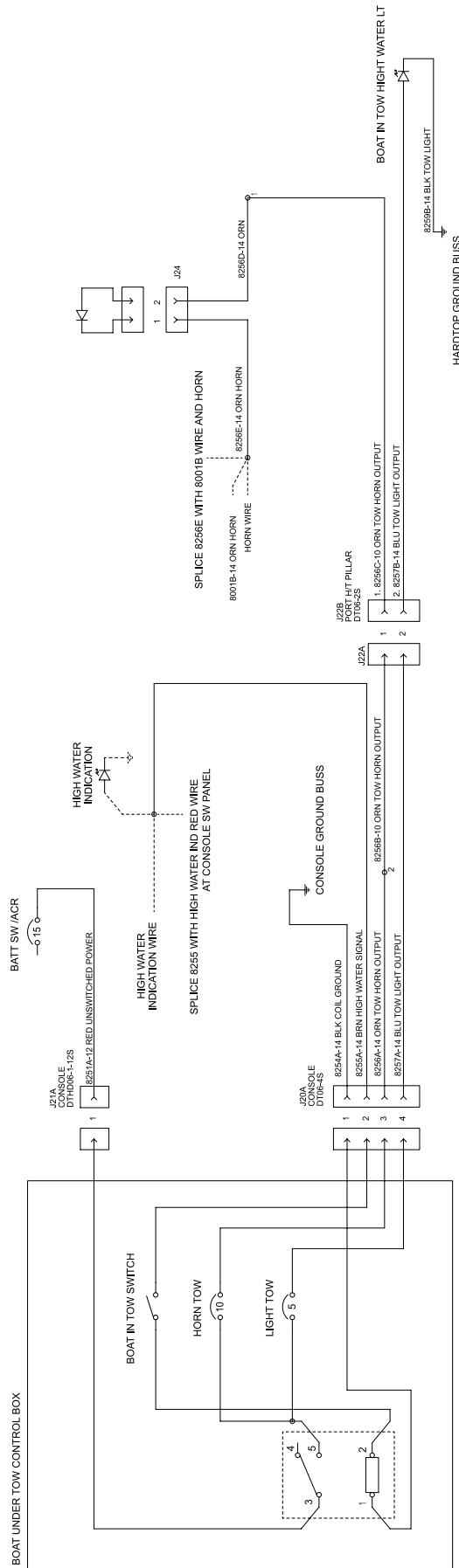

Joystick Piloting - Triple Engine
Figure 4.98.1

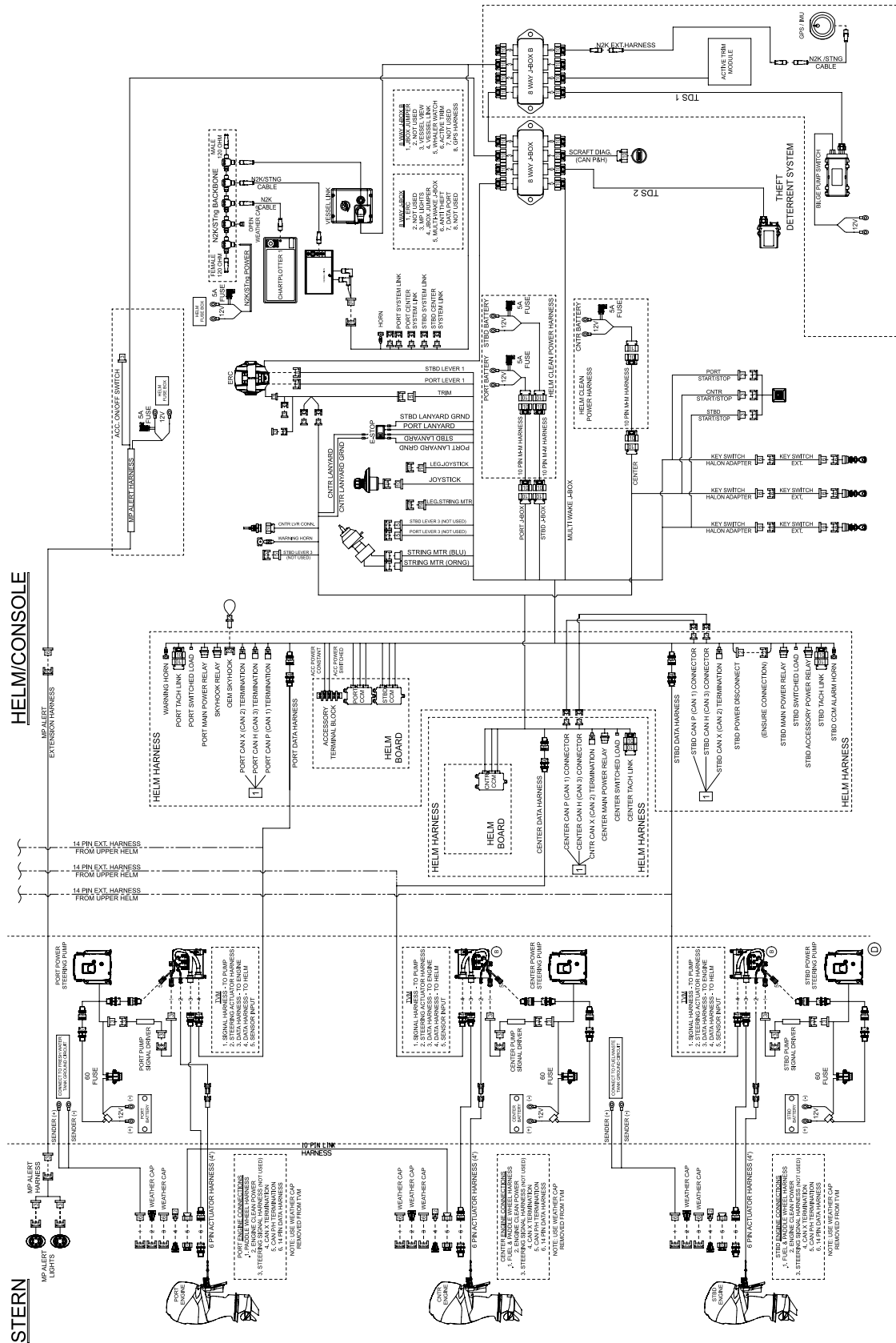

Chapter 4 • Electrical System

Smartcraft - Triple Engine-Sheet 1
Figure 4.99.1

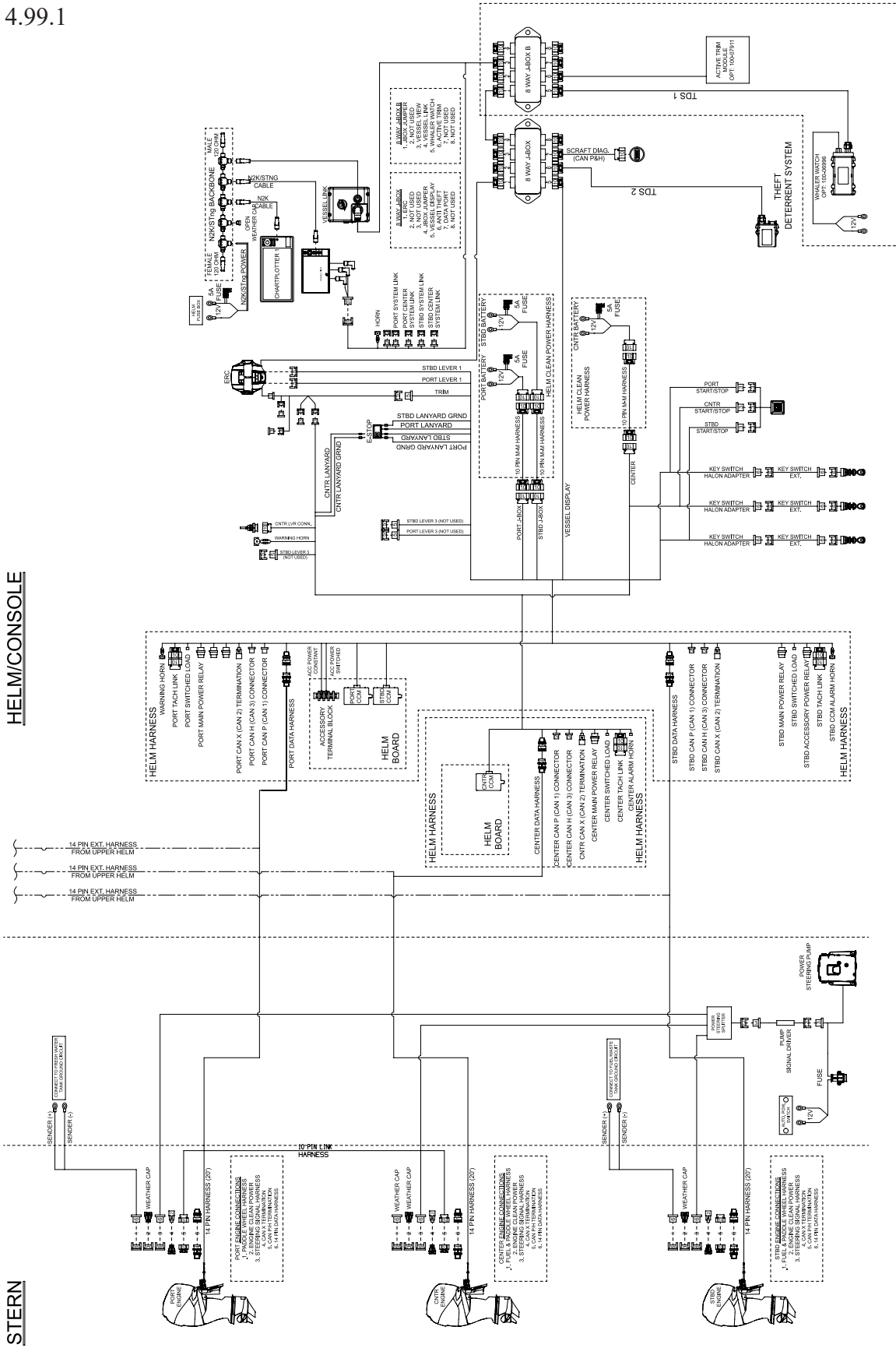

HELM/CONSOLE

STERN

Smartcraft - Triple Engine-Sheet 2
Figure 4.100.1

DUAL HELM/CONSOLE

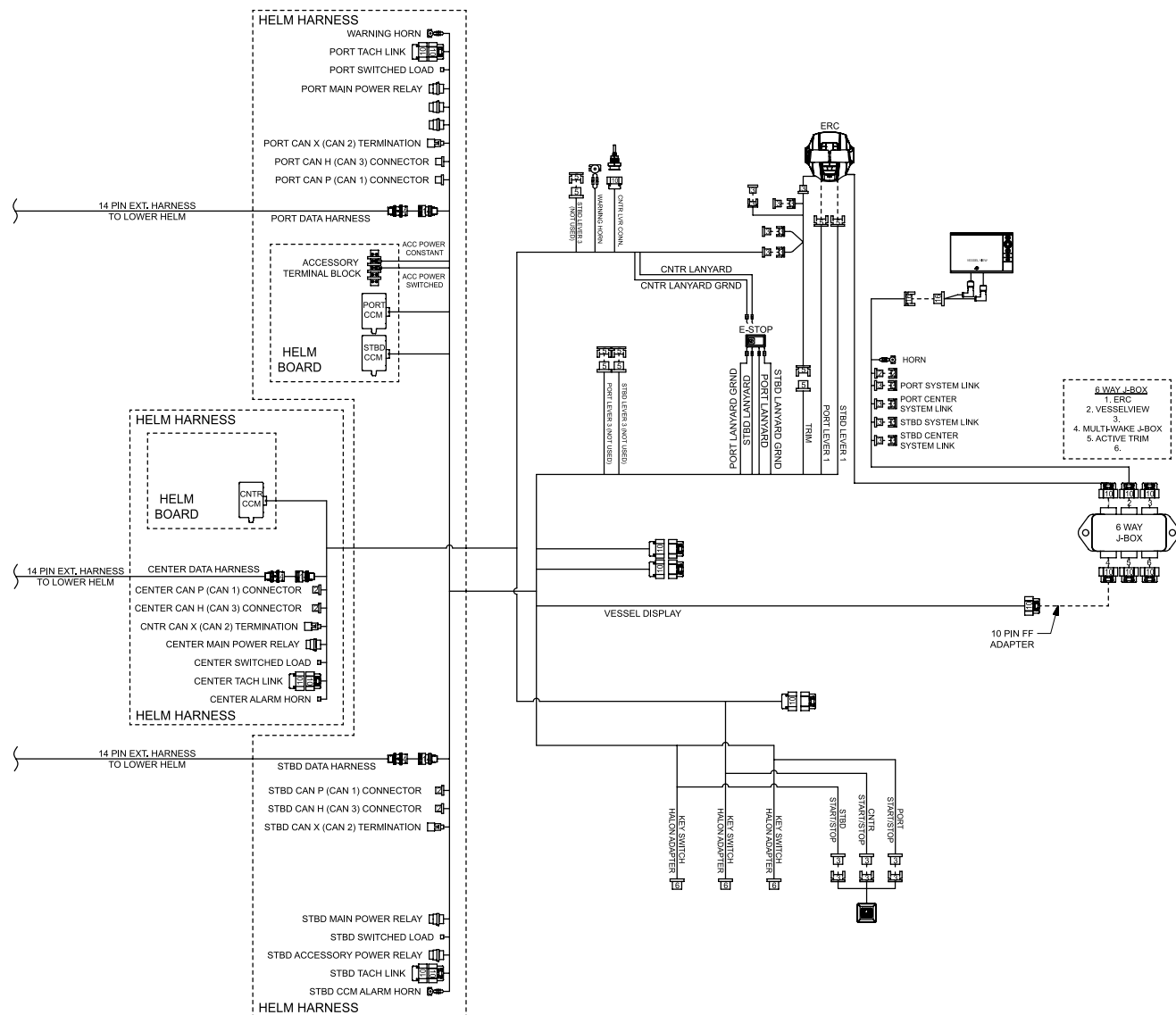

AC System Diagram-120V
Figure 4.101.1

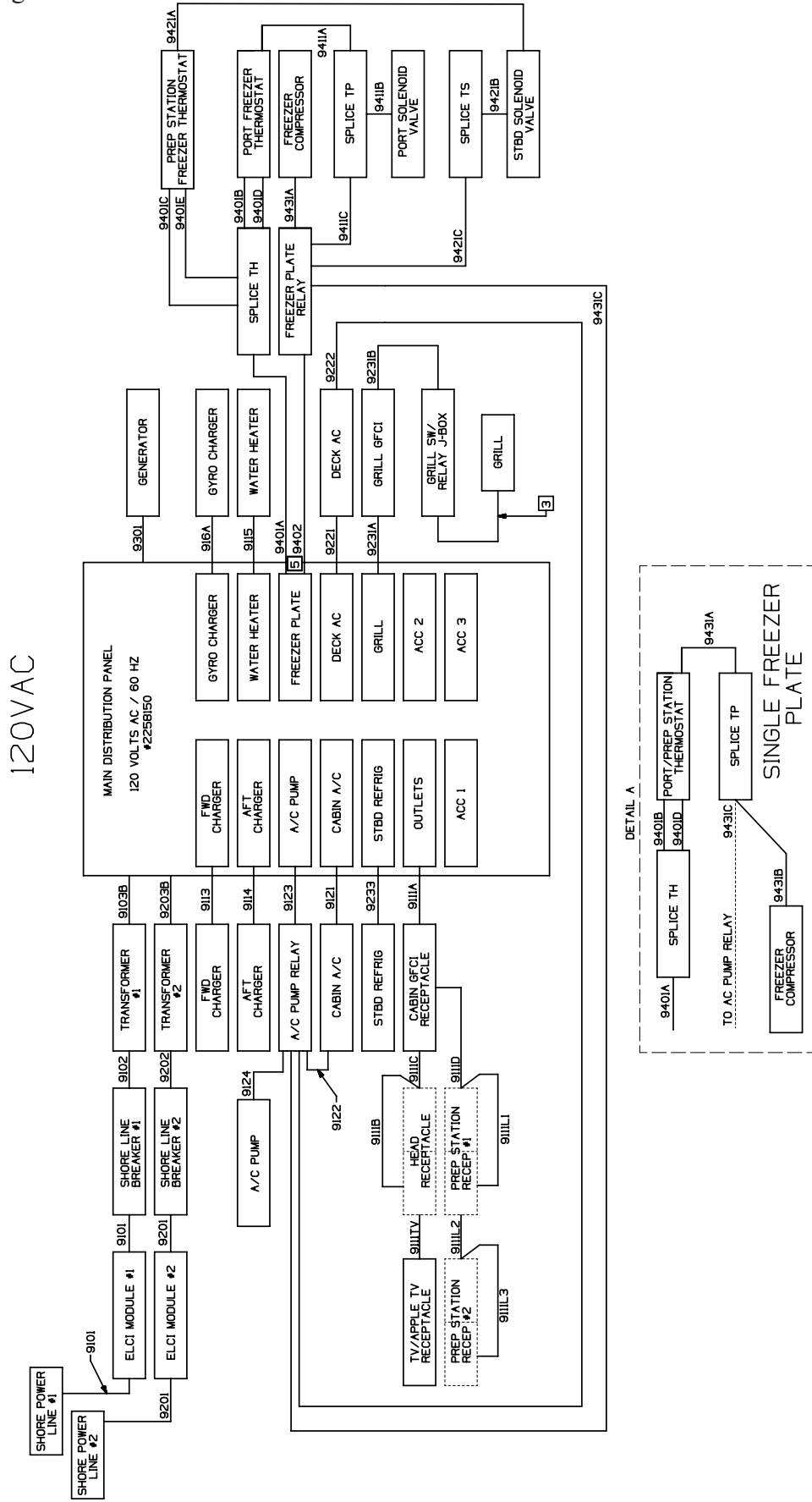

AC System Diagram-230V
Figure 4.102.1

230VAC

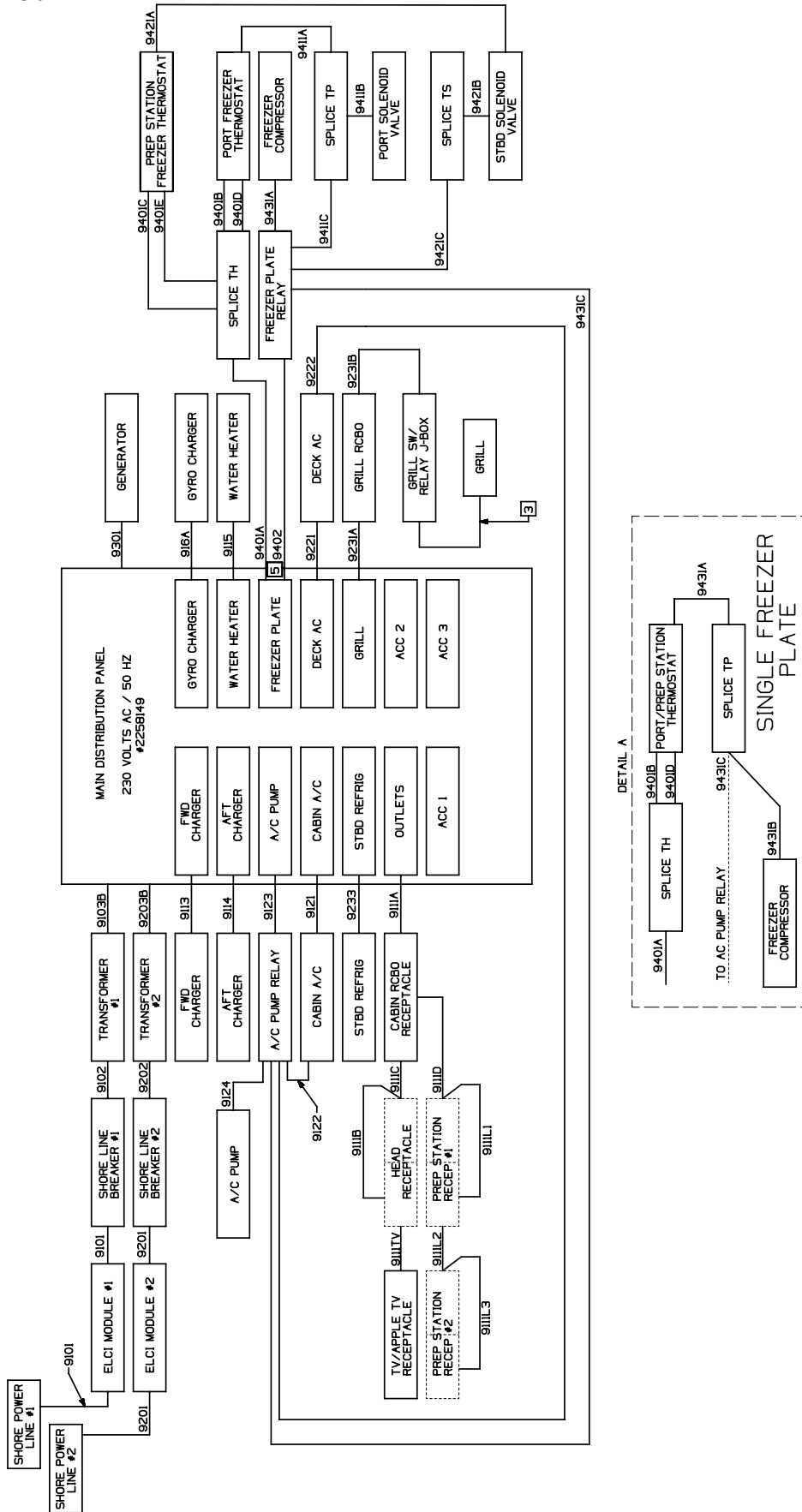

Electronics Diagram-Sheet 2
Figure 4.104.1

UPPER CONSOLE

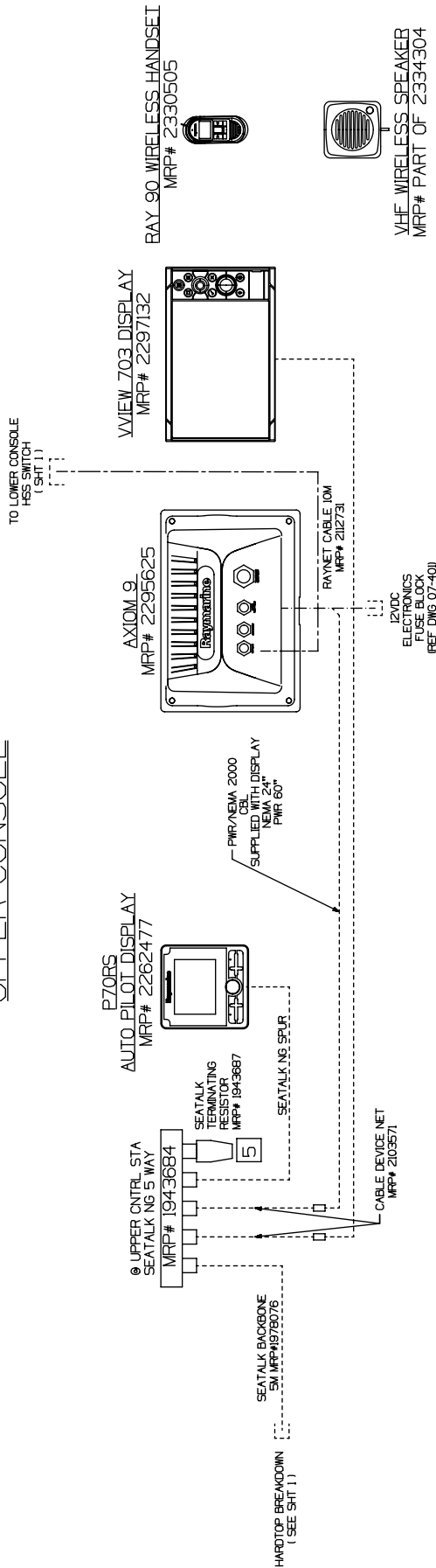

Audio/Video diagram - Standard Layout 1 of 2
Figure 4.105.1

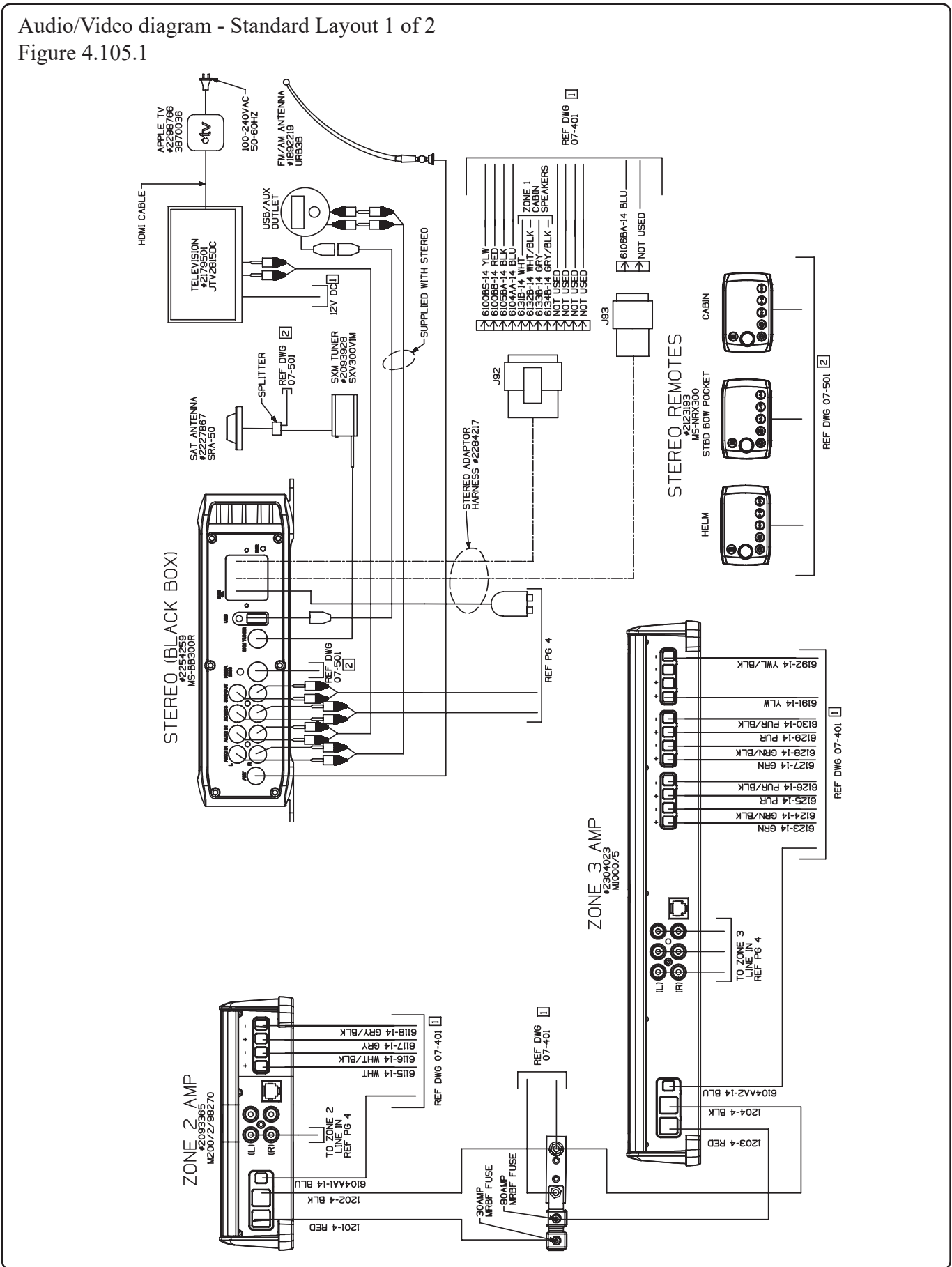

Audio/Video diagram - Standard Layout 2 of 2
Figure 4.106.1

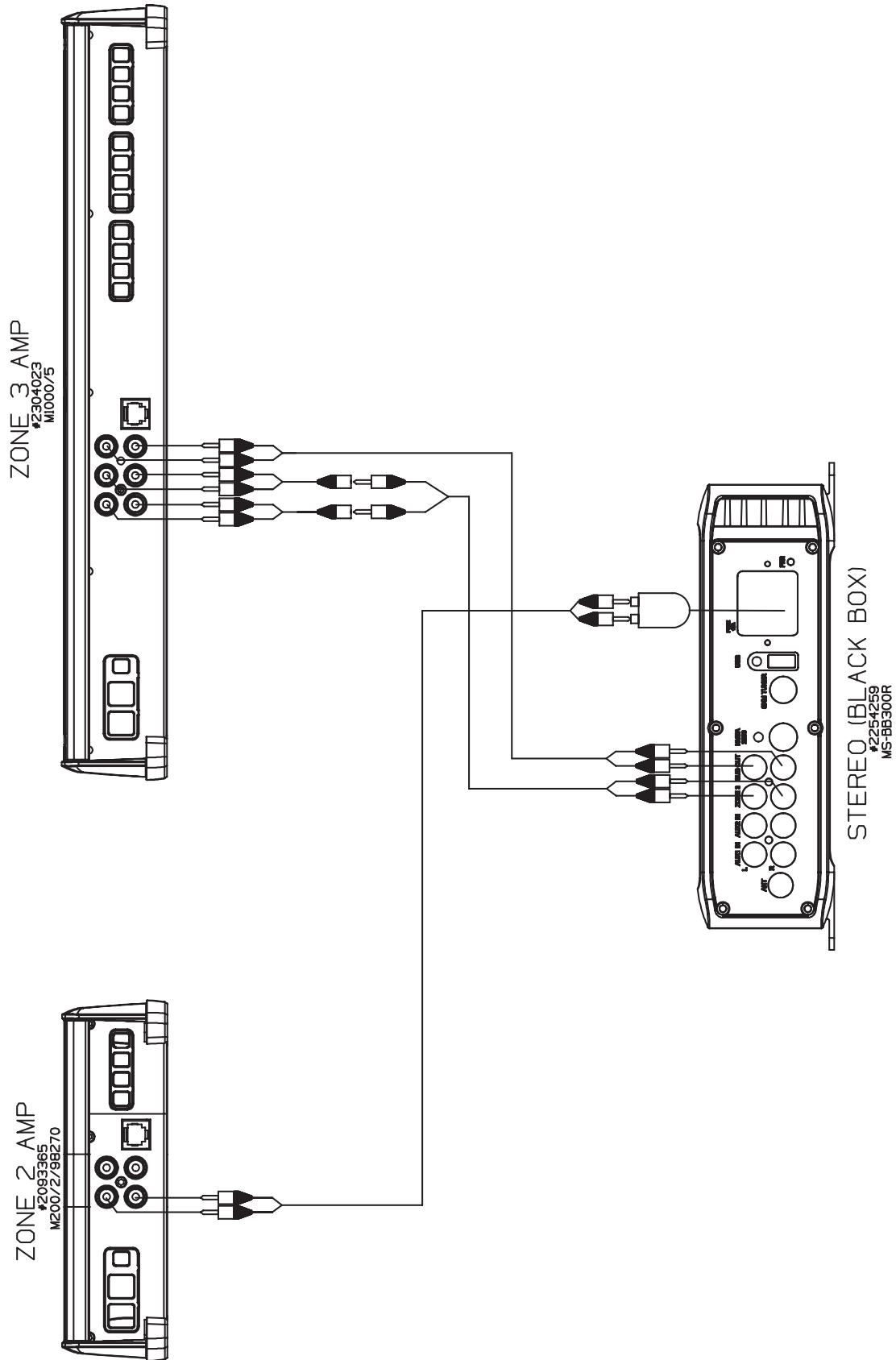

Audio/Video diagram - Premium Layout 1 of 2 (Option)
Figure 4.107.1

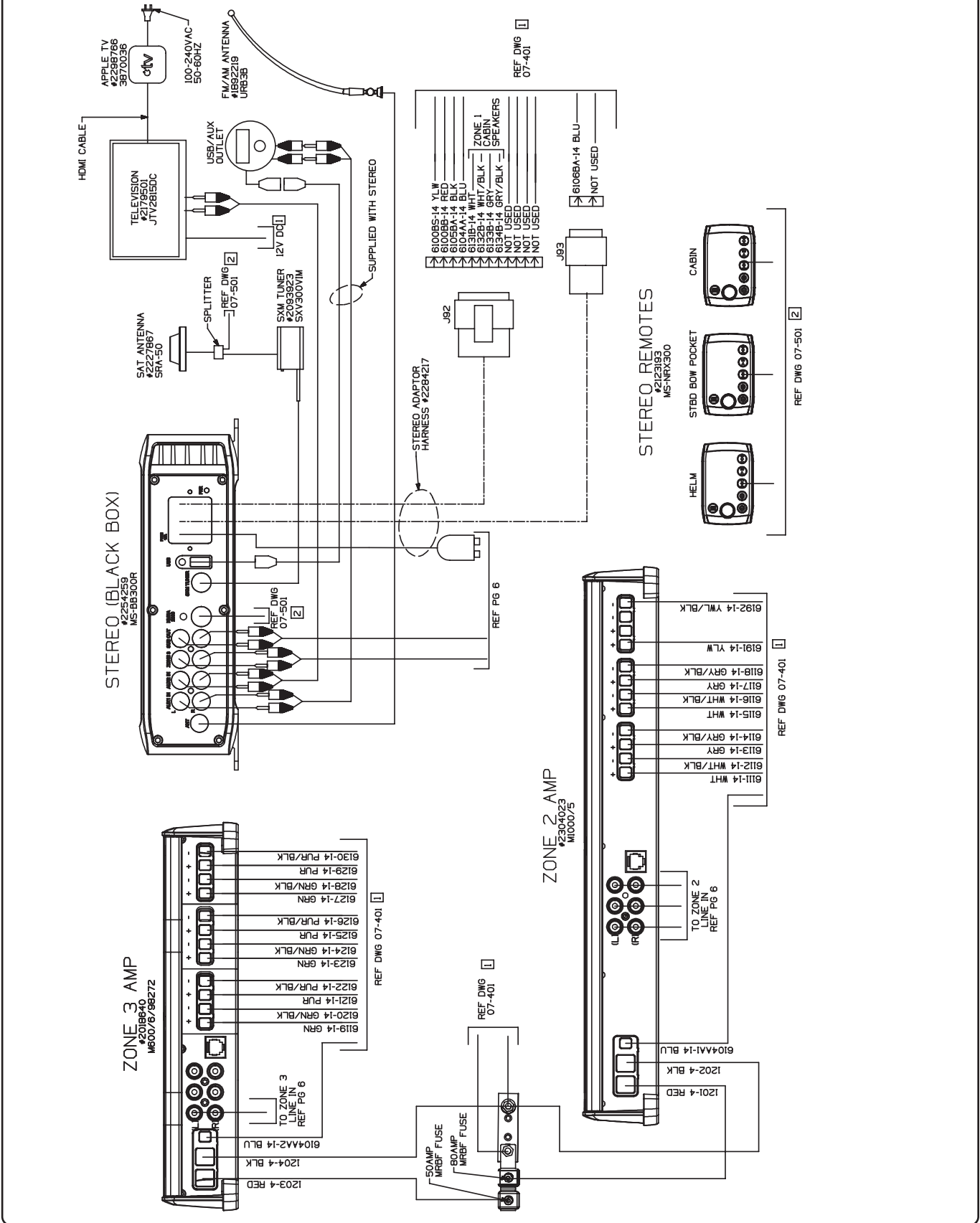

Audio/Video diagram - Premium Layout 2 of 2 (Option)
Figure 4.108.1

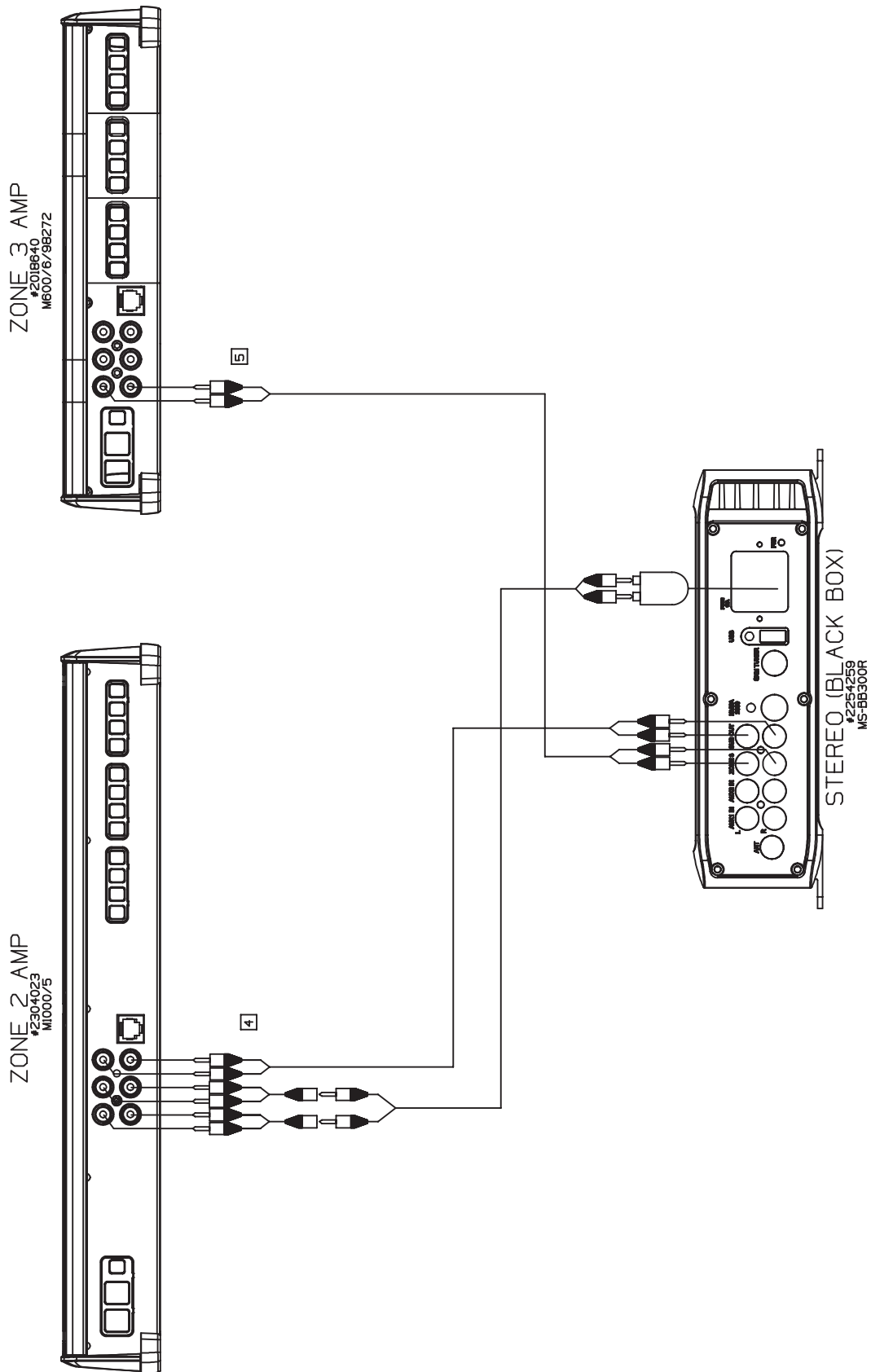

Chapter 4 • Electrical System

Harness, (AC) 120V/60HZ, 220V/50HZ STBD
Figure 4.109.1

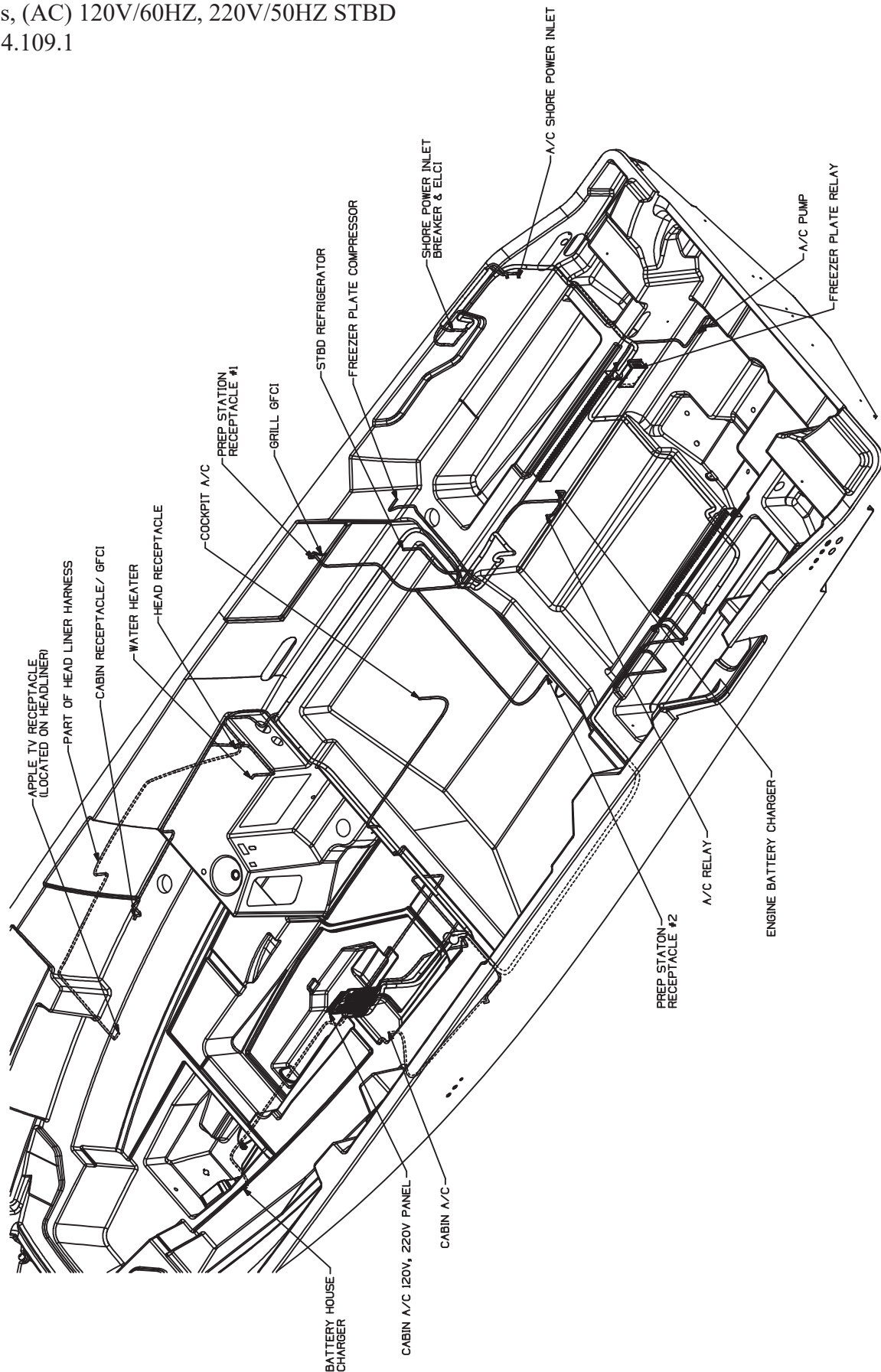

Harness, (AC) 120V/60HZ, 220V/50HZ PORT
Figure 4.110.1

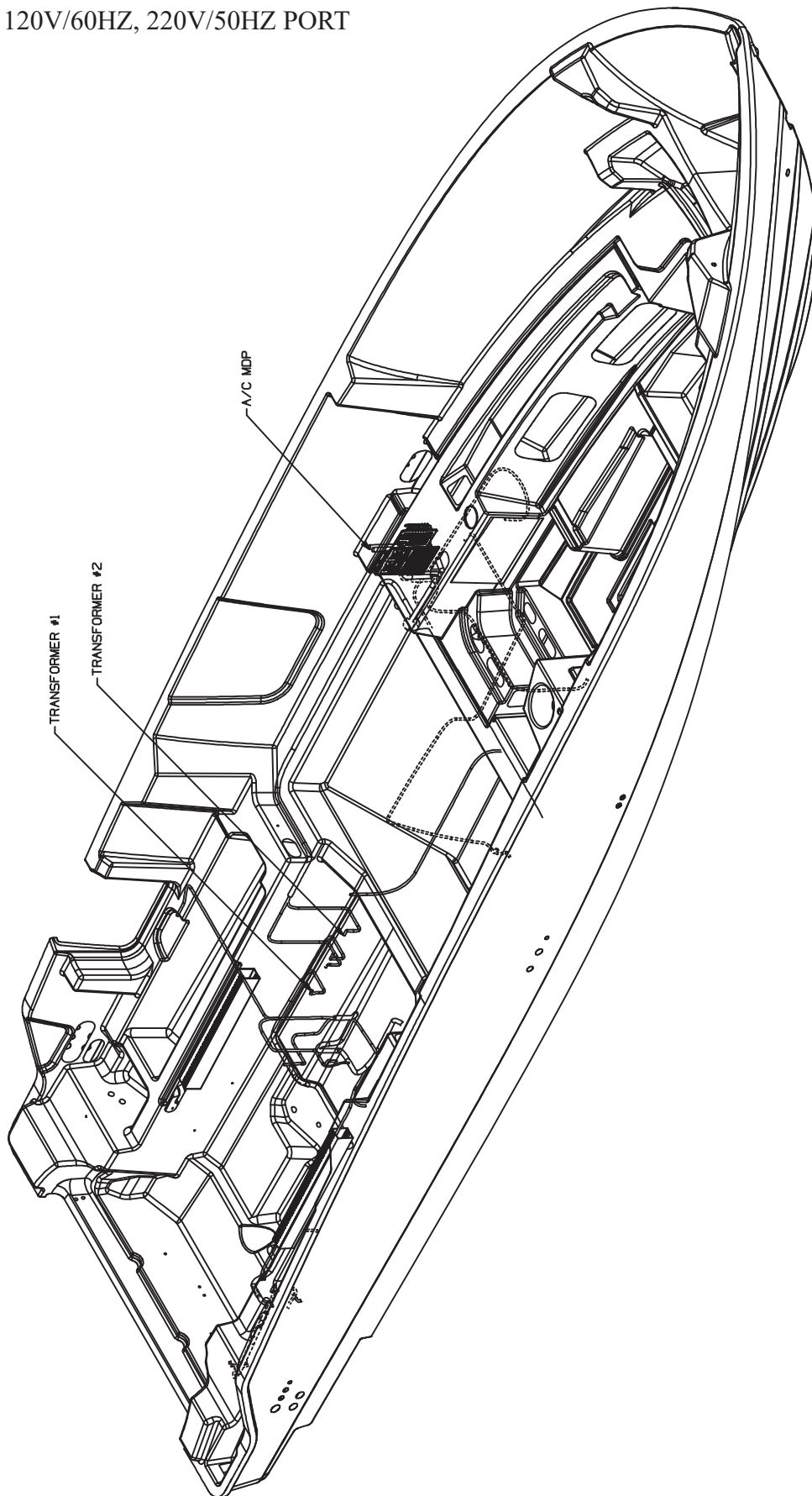

Harness, (DC) Forward Port
Figure 4.111.1

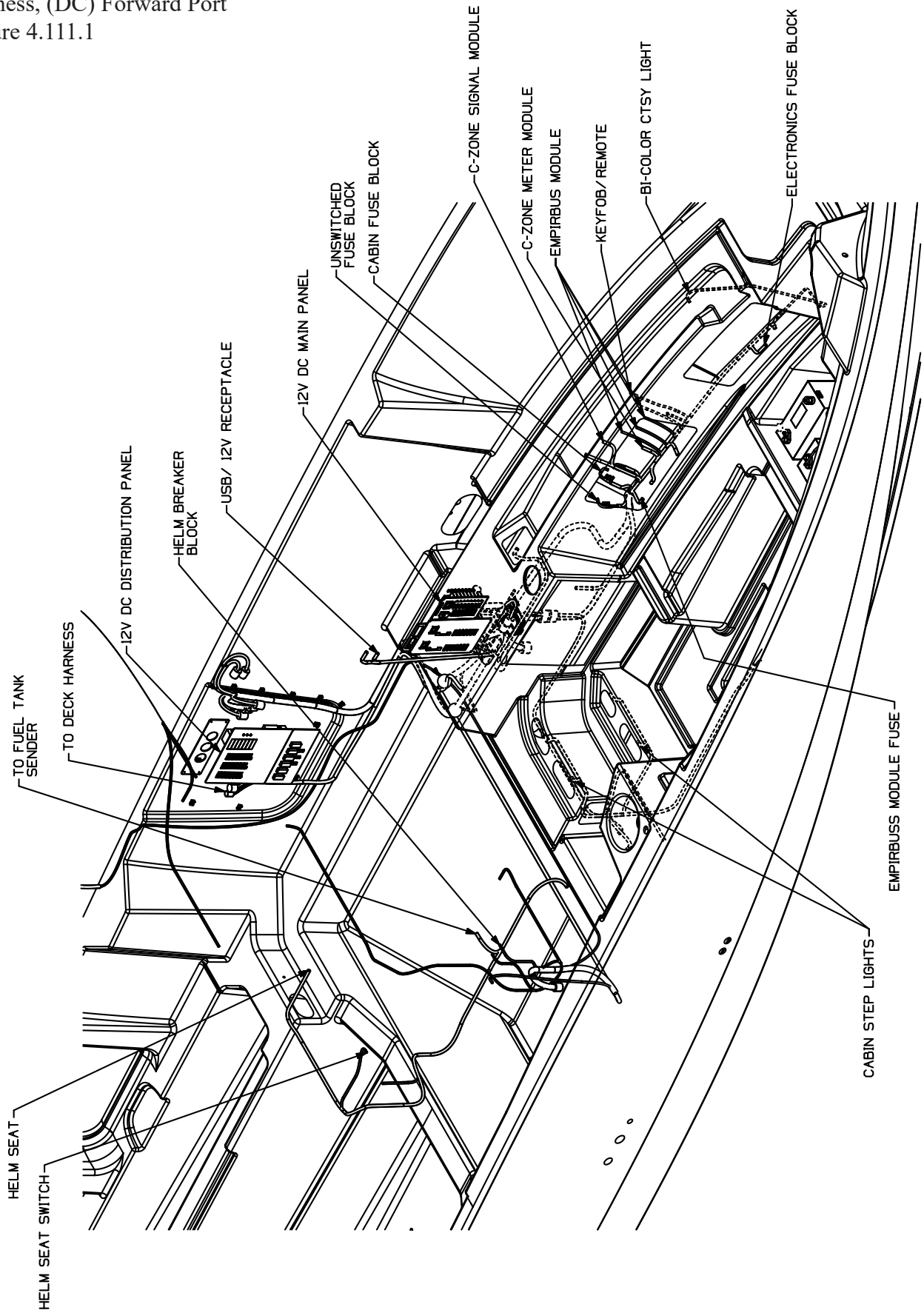

Harness, (DC) Forward Starboard
Figure 4.112.1

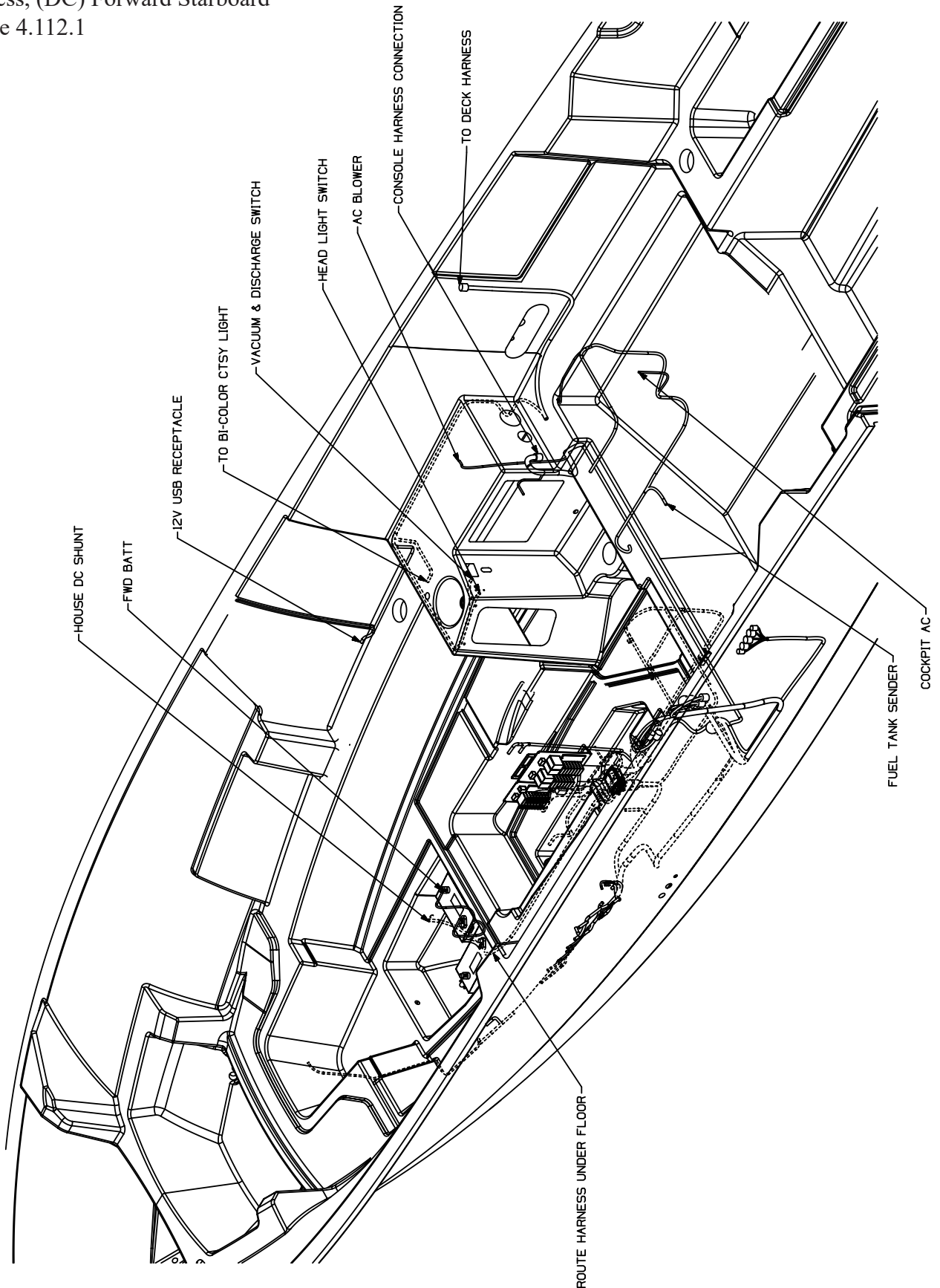

Harness, (DC) AFT STARBOARD & BILGE
Figure 4.113.1

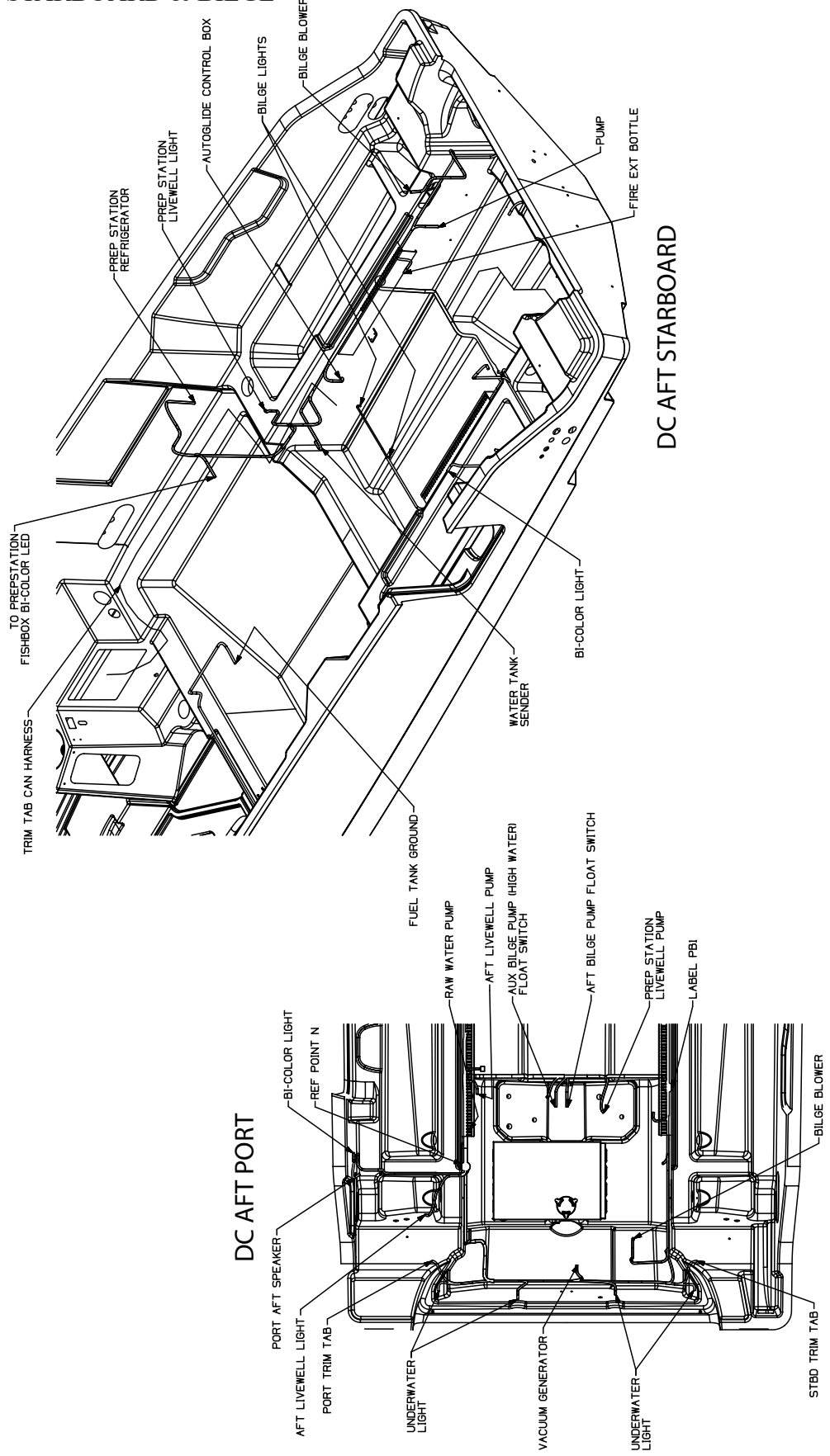

Harness, (DC) Aft Port
Figure 4.114.1

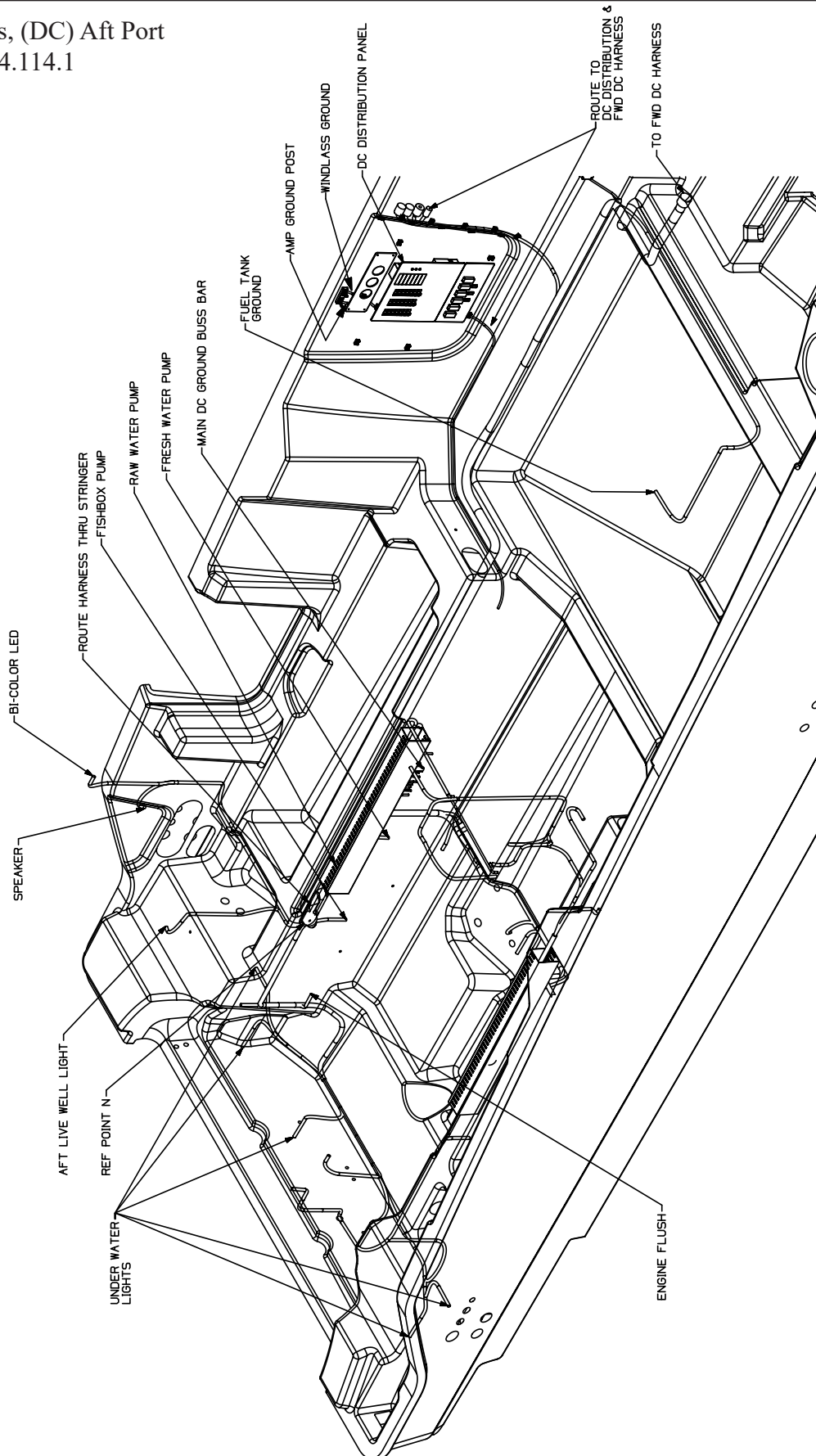

Harness, 30Amp Receptacles (Option)
Figure 4.115.1

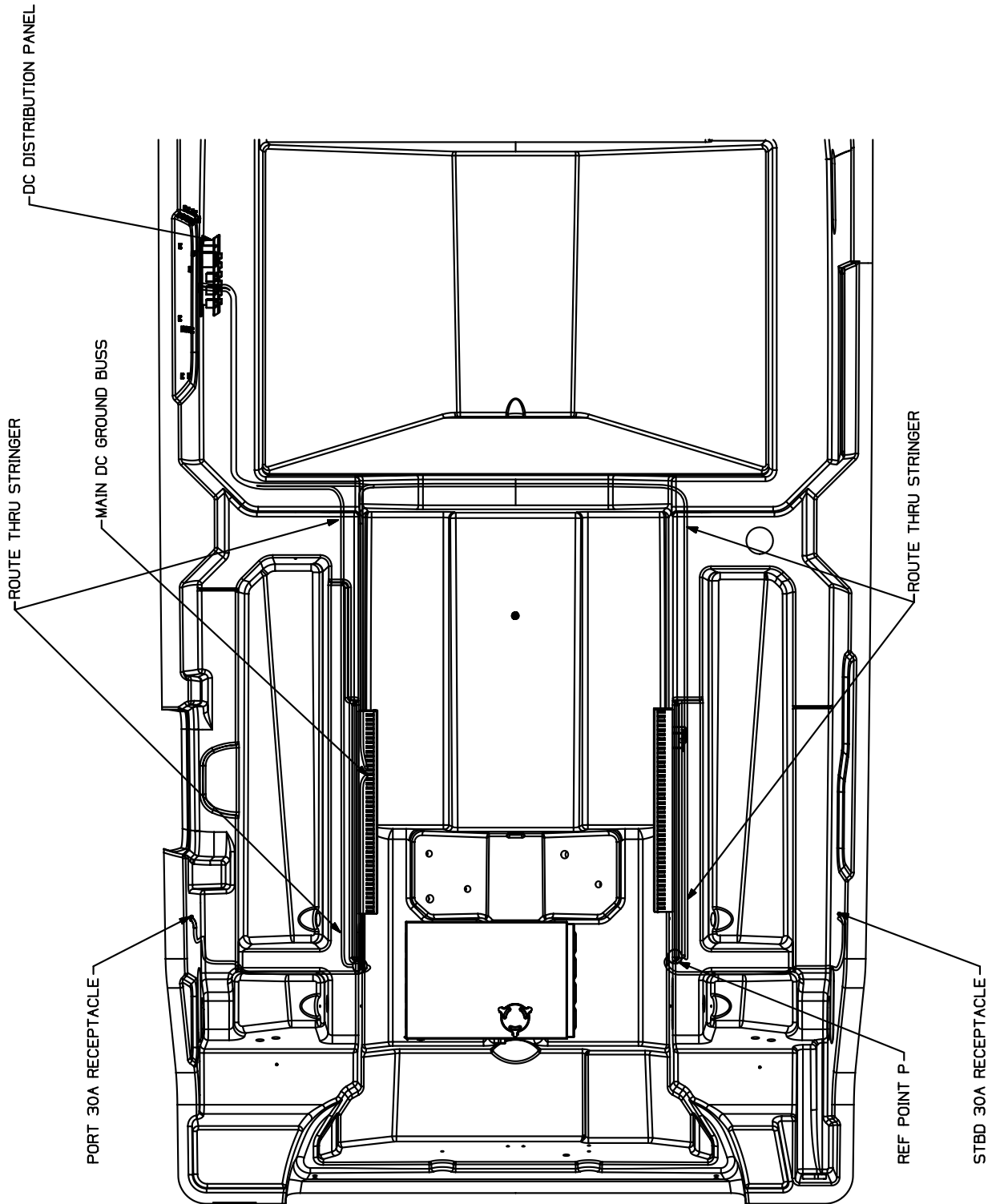

Harness, Bow Thruster
Figure 4.116.1

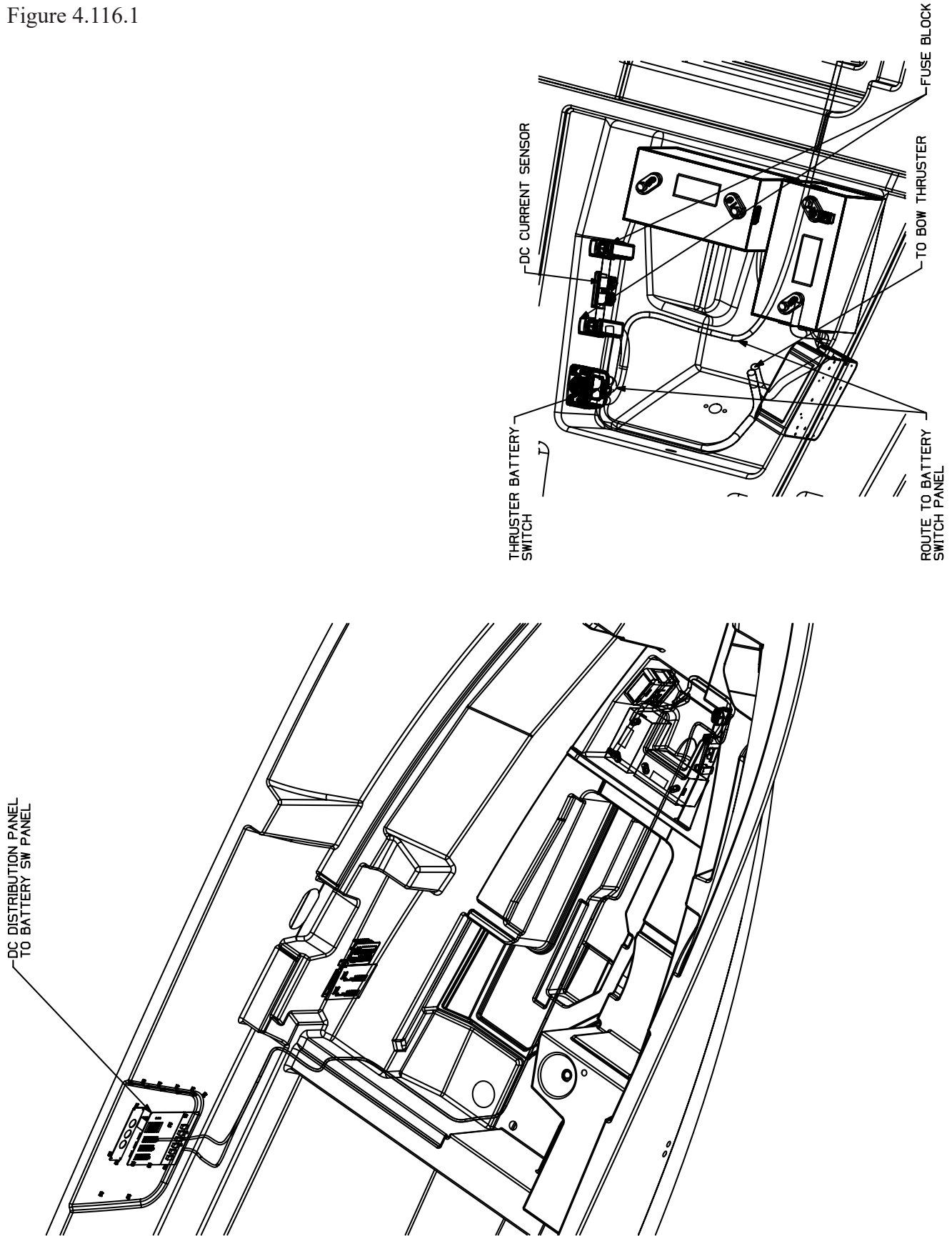

Harness, Console and Headliner
Figure 4.117.1

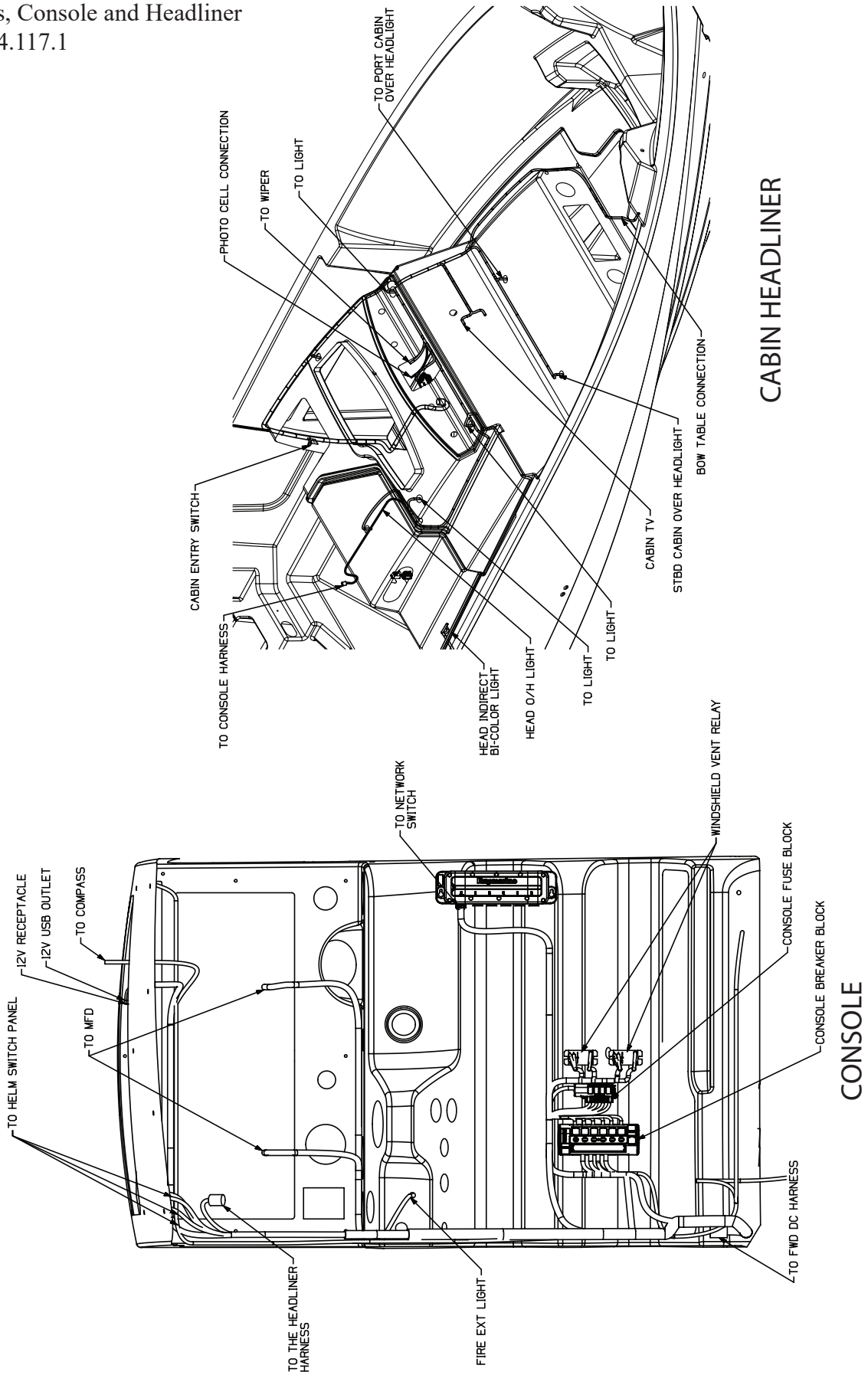

Harness, Hard Top
Figure 4.118.1

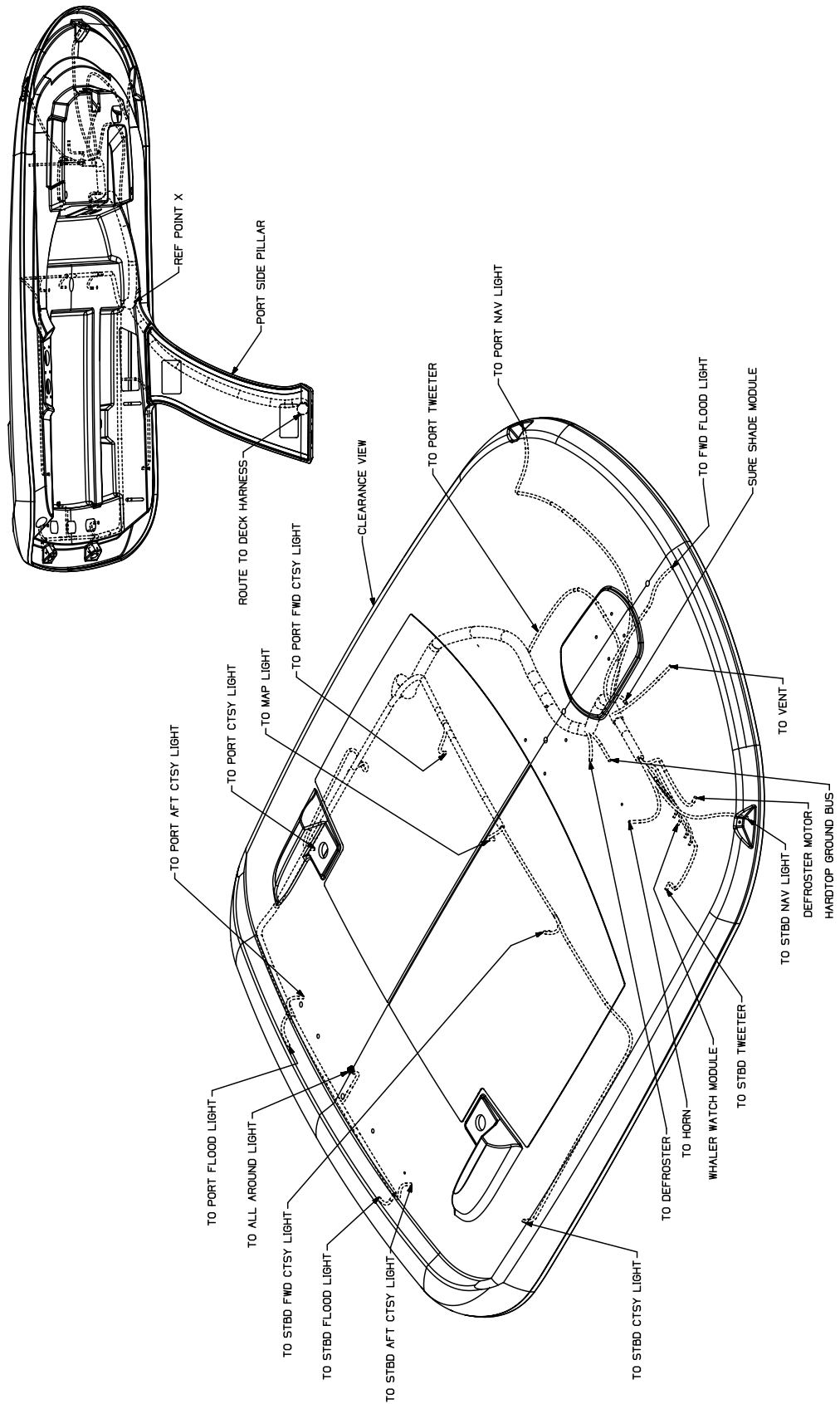

Harness, Upper Station (Option)
Figure 4.119.1

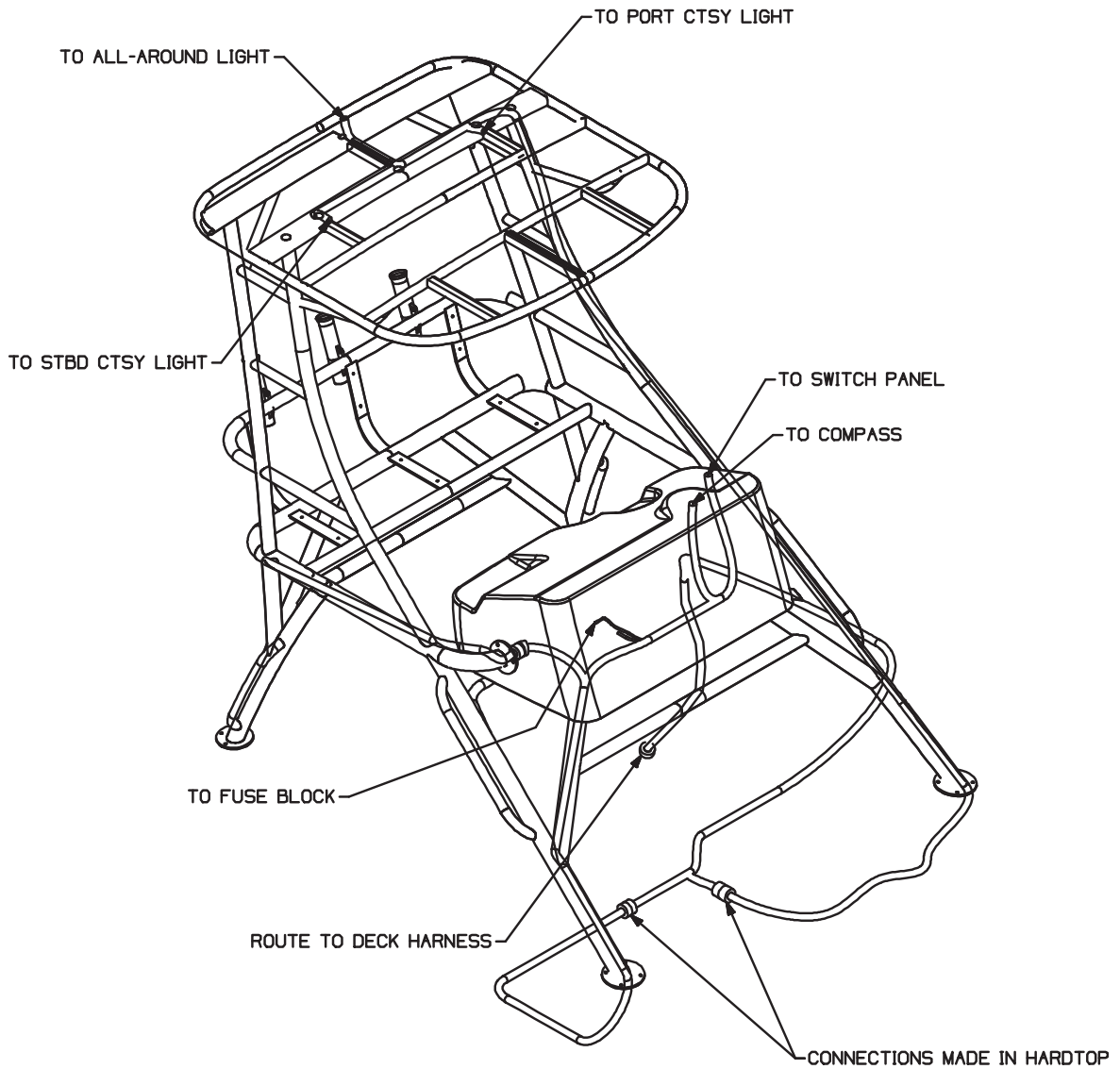

Harness, Bonding
Figure 4.120.1

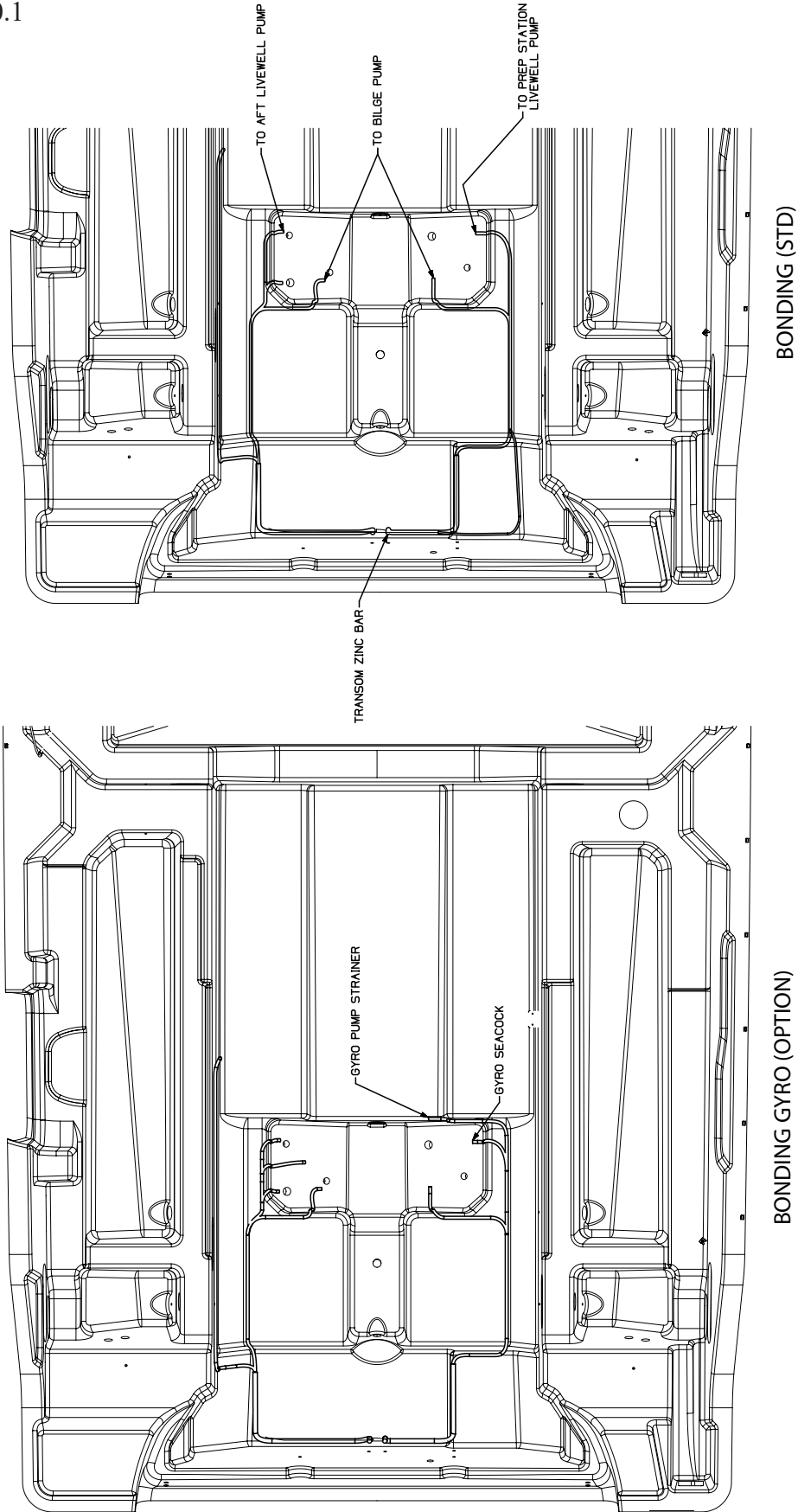

Harness, (DC) Gyroscopic (Option)
Figure 4.121.1

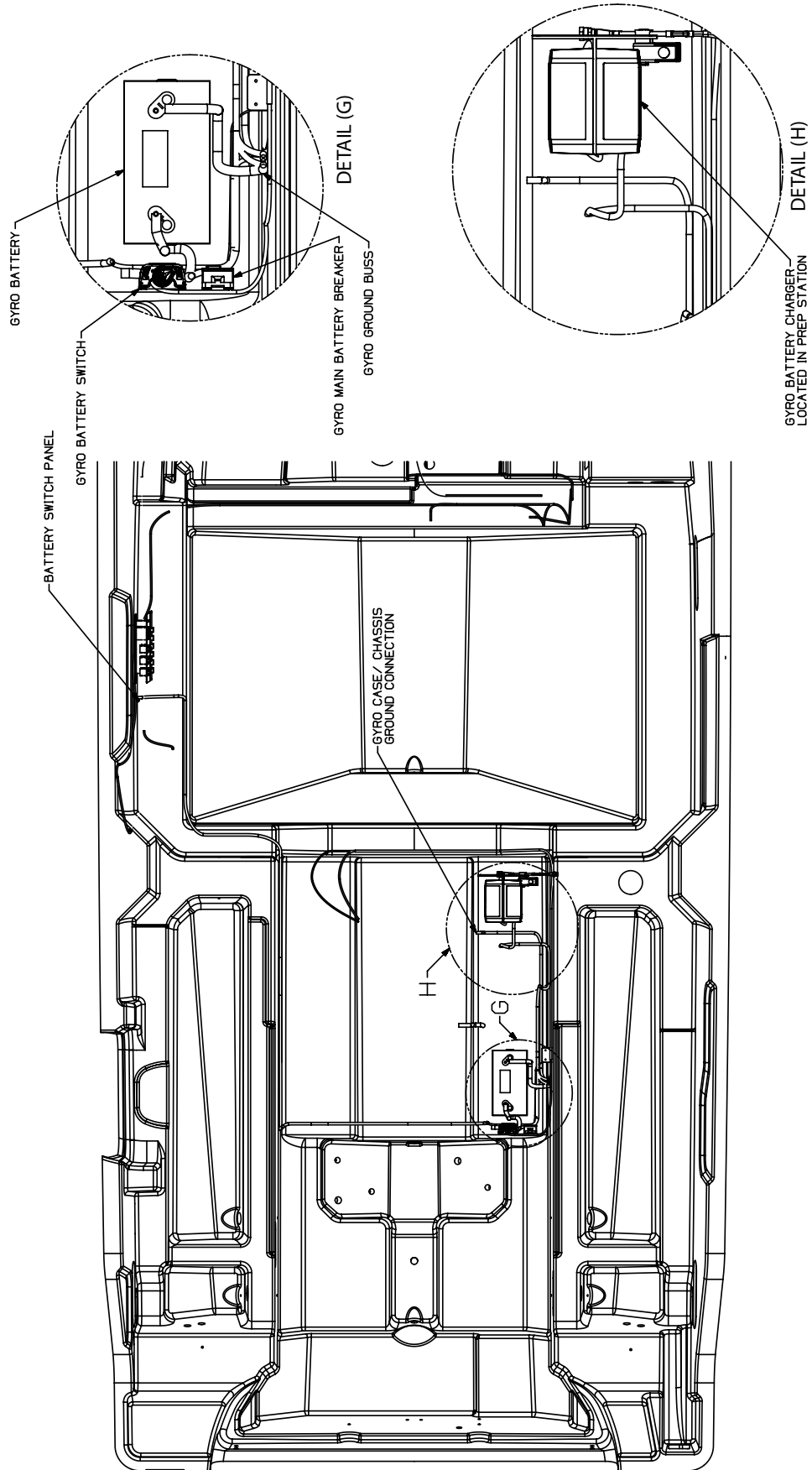

Harness, Freezer Plate (Option)
Figure 4.123.1

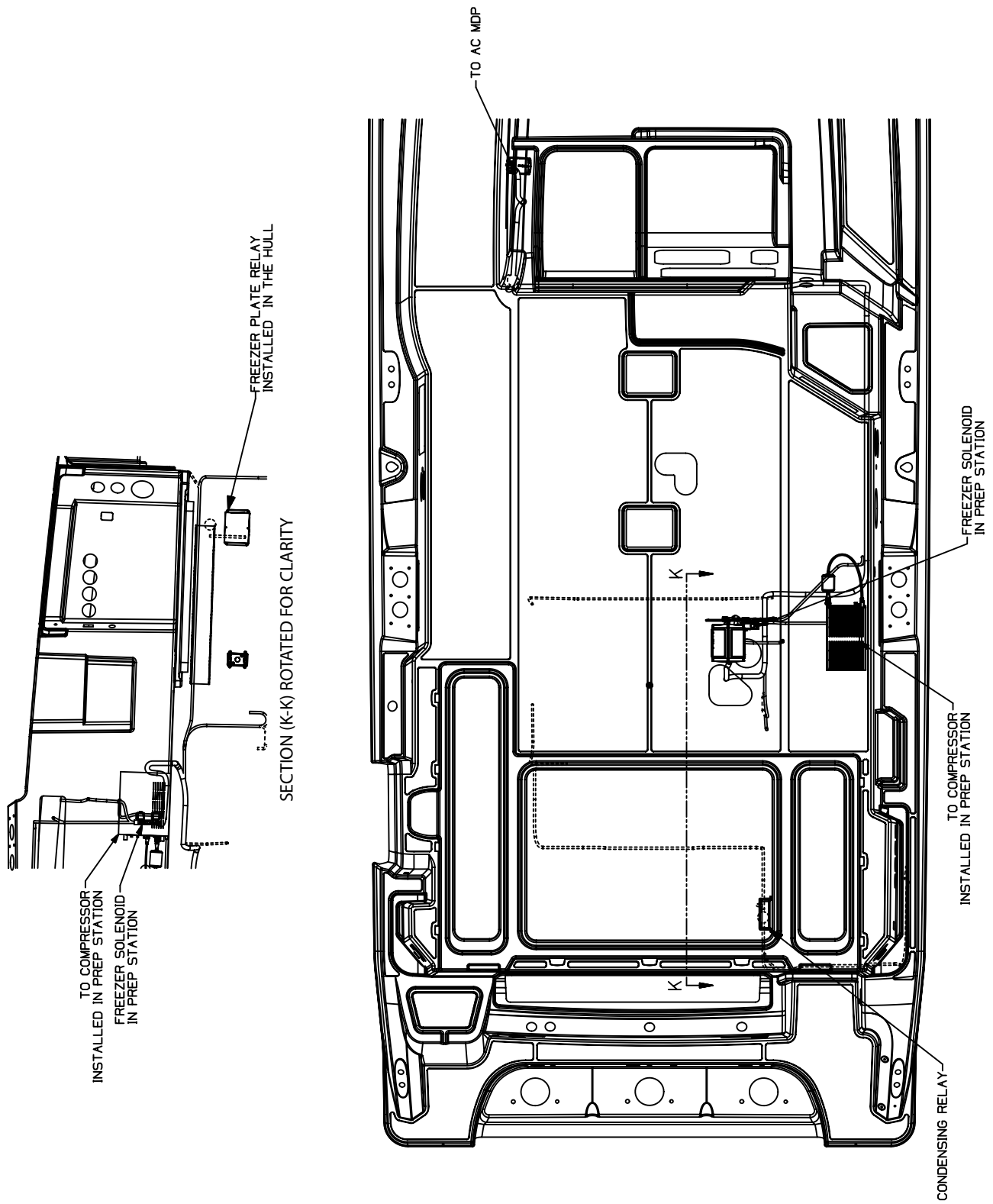

Harness, Gyroscopic Cable Set (Option)
Figure 4.124.1

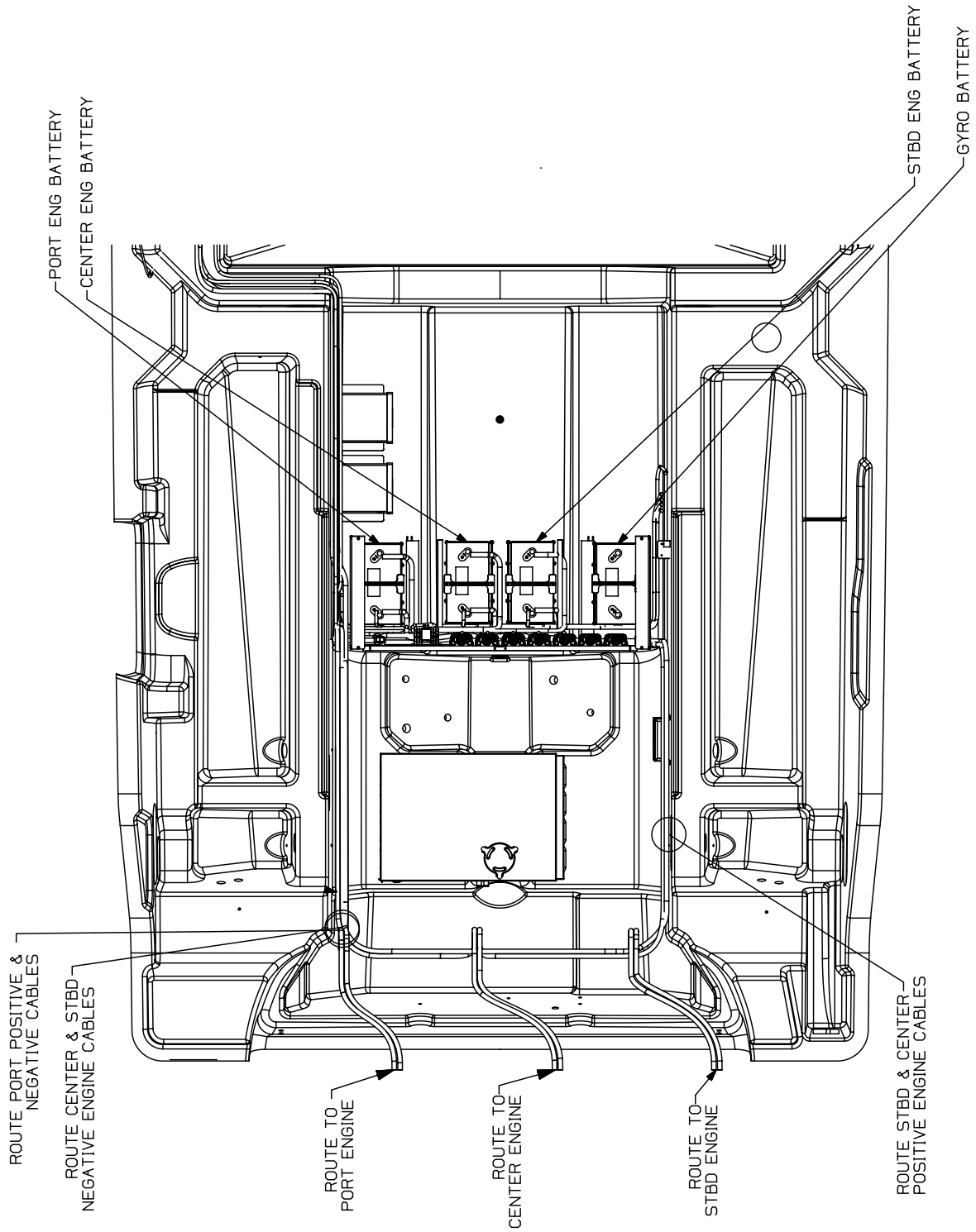

Harness, Generator
Figure 4.125.1

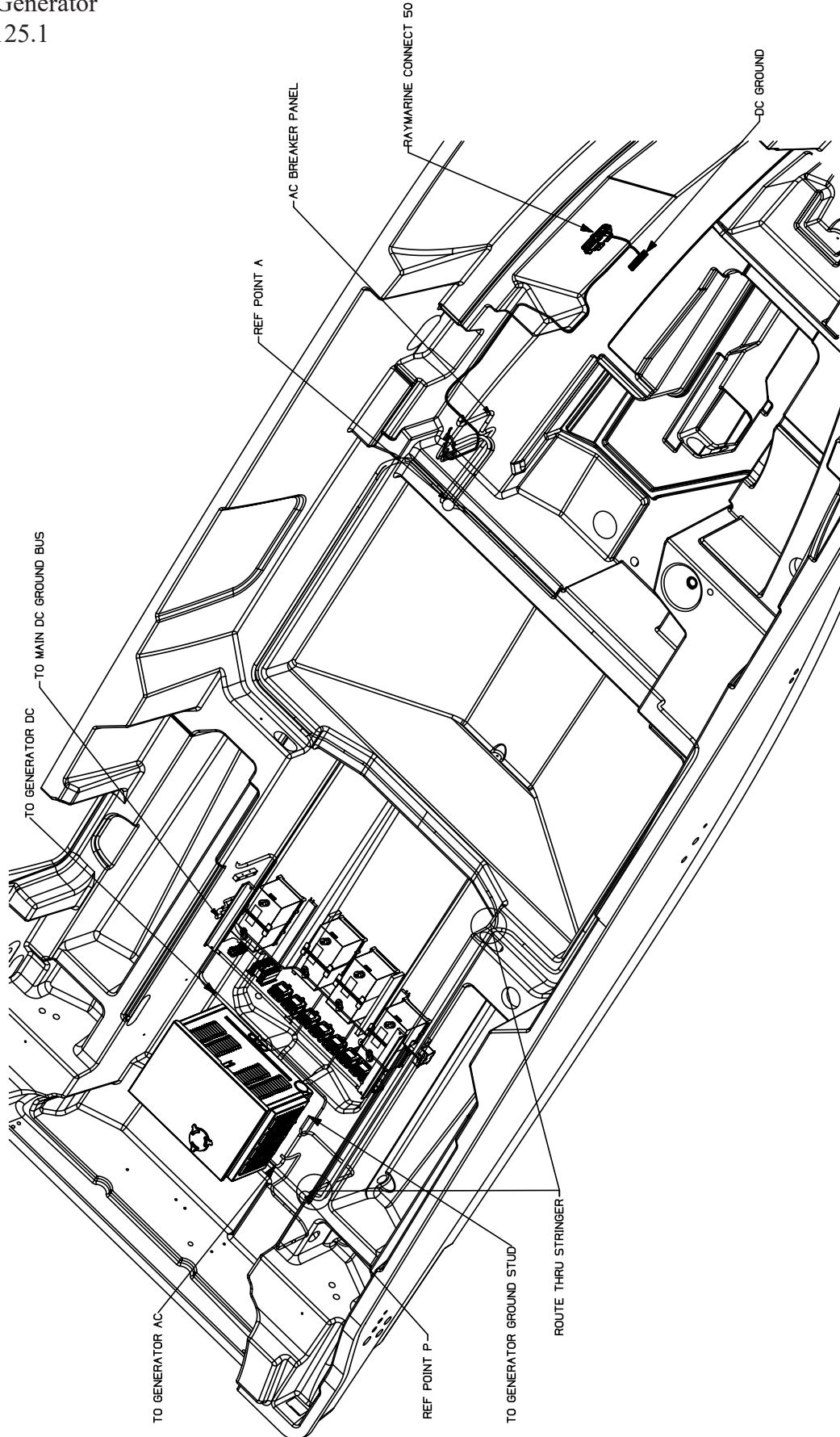

Routine Care & Maintenance

NOTICE

Refer to the individual manufacturers' manuals for important information regarding service, care and maintenance of your boat, equipment and components. Failure to do so may in some cases void the warranty.

Owner's manuals for your boat and each of the various components and equipment can be found in your owner's packet.

⚠ DANGER

When using solvents read all information from the solvent manufacturer regarding safety and handling of the material.

Wear proper protective equipment to ensure your personal safety.

Only use solvents in a well ventilated area and keep all solvents away from open flame and any other forms of ignition.

Routine inspection, service and maintenance of your boat, boat systems and components are vital to assure your safety, as well as prolonging the life of your boat. You should develop regular routines for inspecting and servicing your boat.

⚠ WARNING

IMPORTANT

Regularly inspect and test hardware, fittings, windshields, hatches, seams, etc. for proper seal. Reseal and/or readjust/tighten fittings, latches, etc. as needed.

The interval between necessary service or maintenance is highly variable, depending on the environment in which your boat will be used. For example, corrosion of boat parts and components will occur far more rapidly in a salt water environment than on a boat which is used in fresh water. This section provides only general guidelines for the care and cleaning of your boat. It is your responsibility to determine whether maintenance and care intervals need to be accelerated due to your boat usage and/or operating environment.

Hull

Fresh water, saltwater and water temperature can all affect the types of growth that you will find on your boat's hull.

Any growth will affect the boat's performance and overall look. If it has been a while between inspections you might notice algae or slime growth on the hull. This can be cleaned with a coarse towel or soft bristle brush. The growth should be cleaned immediately after the boat has been removed from the water. If the growth is allowed to dry it will be much harder to remove.

Compounding may be necessary to remove more stubborn stains and chalking from the surface of your boat. If compounding is necessary it must be done after a thorough washing and prior to waxing.

If the growth is more severe, you may need to enlist the services of a professional hull cleaning company.

Check with your Boston Whaler dealer for recommendations on a compatible rubbing compound for your boat or a professional hull cleaning company in your area.

Waxing the Gel Coat Surfaces

Waxing is necessary to provide added protection to the gel coat. A periodic good cleaning and waxing will also ensure that your boat will be protected and look good longer.

NOTICE

Waxing of the exterior surfaces is recommended to be done at least twice a year to protect the gel coat of your boat.

Do not wax over dirt. Make sure the surface of your boat has received a thorough washing and rinsing and is clean before waxing. If a rubbing compound has been necessary, make sure that any minor scratches or surface pitting is cleaned of compound residue. Use a good quality carnauba wax or a high quality wax designed for marine gel coat. Apply several coats.

Hull Maintenance

If using a pressure washer to clean the hull and deck surfaces of your boat it is important that you use the wide fan nozzle only and move the spray head in a continuous motion. Do not concentrate the high pressure on a small area of the boat surface and never use the fine pinpoint nozzle as the concentrated stream can cause damage to the surface of your boat.

It is also recommended that you refrain from pressure washing the console as high pressure may compromise the integrity of the electronics and gauges as well as other equipment installed on your boat. Also avoid pressure washing all caulk seams.

When staining from build-up does occur, use only cleaning agents that are recommended for marine gel coat for use on those stubborn stains.

- Never use an abrasive cleaner to wash your boat's hull.
- Never use an abrasive pad to attempt to remove stubborn stains.
- Never use strong solvents to clean.
- Never apply tape or any other type of adhesives directly to the painted surfaces on your boat.

Use care when covering your boat's painted surfaces as tarps and other such covers can trap dirt and cause chafing. It is best to use a frame of either aluminum or wood to keep the cover up and allow air to circulate.

Hull Blistering

Due to the quality of the materials used in the hulls of Boston Whalers, blistering is rarely ever seen. Blistering is caused by water soluble materials in the hull laminate. The fiberglass and resin structure of your boat is porous. However, intrusion of water into the gel coat will take some time. The effect of osmotic pressure allows water to impregnate below the gel coat and substrate thus forming a blister.

There have been extensive university studies funded by the United States Coast Guard regarding the cause and effect of blistering in the gel coat of fiberglass boats. Fiberglass blisters can form anywhere from

near-surface layers of the gel coat to very deep into the fiberglass structure. The damage can range from cosmetic to catastrophic, (although the latter is a very rare occurrence). The studies seemed to point toward long term immersion of the hull in warm water as a primary cause of hull blisters. Stress cracks on the hull below the waterline also contribute to the formation of hull blisters.

Prevention

There are a variety of ways to prevent the formation of hull blistering. Epoxy coatings can be applied to the hull, followed by hull painting. An alkyd-urethane-silicone marine paint can also be used to aid in the prevention of hull blisters.

Reducing the amount of time that your boat stays in the water also helps prevent hull blisters from forming. Use of a trailer or boat lift will reduce the likelihood of hull blisters forming. Be sure to use a bunk type lift or trailer for storage of the boat out of water.

Contact your Boston Whaler dealer for more information on the prevention and treatment of hull blisters.

Bottom Painting

DANGER

There are risks and dangers inherent with the use of paints and solvents. Dispose properly of all rags, rollers and trays used for painting. Follow all the precautions and regulations listed by the manufacturer before and after painting your boats hull.

NOTICE

If blisters are present in the hull, they need to be properly cleaned and dried out before any barrier protection can be applied.

CAUTION

Some bottom paints contain metals that can cause corrosion of the outboard engine. Leave a minimum of 3/4" unpainted around all engine parts. Use only a paint specifically designed for aluminum engines as anti fouling protection.

If your boat will spend most of its time in the water, painting the bottom of your boat's hull is a good way to slow the formation of hull blisters and to keep bottom growth (fouling) under control.

If you will be trailering the boat to and from the water, you might want to forgo the painting.

Following is an abbreviated section on painting your hull bottom. Your Boston Whaler dealer should have information on properly painting your boat's hull or recommendations on businesses that will paint your hull for you.

Zinc Anodes

Sacrificial anodes (zinc) are installed on the transom, trim tabs, and engines of your boat to protect underwater hardware. Zinc, being less noble than copper based alloys and aluminum used in underwater fittings, will deteriorate first and protect the underwater fittings from deterioration.

Zinc anodes cannot perform their function unless they are exposed. Putting paint on an anode smothers it, rendering it useless.

CAUTION

Do not paint over zinc plates. This action will render them useless and lead to deterioration of the underwater metal parts of your boat.

Bottom Painting a Bare Hull

Since the boat has never been painted preparation is the key to successful hull painting. Take extra care and time in preparation before proceeding to paint.

Begin by scrubbing the surface thoroughly with a stiff brush using an all-purpose marine soap and water to remove loose dirt and contamination. Flush with fresh water to remove all soap residue.

WARNING

Proper ventilation and capture of the dust created by sanding is essential. The dust created by sanding is toxic and should not be breathed. A proper fitting respirator must be used.

Do not use a paper filter mask.

The gelcoat will have to be dewaxed of mold release wax before sanding can begin, otherwise the wax will be dragged into the scratches and will reduce the adhesion properties of the paint.

Remove any mold release wax that may be present using fiberglass surface prep solvent and a scrub pad. Scrub only a few square feet at a time. Flush with fresh water. If the water beads up or separates, continue scrubbing the surface. When the water sheets off, the wax contaminate has been removed.

After the dewaxing is complete, application of a primer coat is recommended. Pay close attention to scratches, nicks and dings in the surface. If necessary, fill any repair areas with a watertight epoxy filler. After filler is cured, sand with 80 grit paper until smooth. Remove the sanding residue using a fiberglass solvent wash.

The paint can be applied after sanding and cleaning is complete. Follow the paint manufacturer's recommendations for application.

Bottom Painting a Pre-Painted Hull

WARNING

Bottom paint is designed to resist algae growth which means it has chemicals embedded in the paint that are harmful if ingested. Take all necessary precautions required before painting or repainting your boat's hull.

If the hull bottom is already painted, you must be sure to test the paint's adhesion to the already painted surface. If the paints are incompatible, the new paint will not adhere to the hull bottom or the paint will "lift" the old paint. Never apply paint without first

NOTICE

Painting your boat's hull will adversely affect the boat's speed and performance and may require re-propping if the maximum engine RPMs drop below the engine model/mfg recommended operating range.

preparing the old painted surface following the paint manufacturer's recommendations.

Follow the paint manufacturer's recommendation for applying the paint. Humidity and weather will play a role in how and when the paint is applied. Several thin layers are better than one thick layer.

To determine the waterline, you will need to place the boat in water with a full load of fuel and gear. Mark the waterline and measure above the marked line 1 to 3 inches for placement of the tape line.

Make sure that there is enough paint left to cover areas that were not accessible, (slings, jack stands etc.) and paint accordingly. Follow the paint manufacturer's recommendation for do's and don't's after the painting is complete.

NOTICE

Masking tape is not recommended for the types of paint you will be using.

Rubrail Care

The rubrail on your boat is constructed of an injected high density PVC vinyl material which laboratory tests have proven to be highly resistant to staining, fading and cracking.

As resilient as this material is, you still need to follow some basic maintenance precautions.

General maintenance requires a thorough cleaning with mild soap & water. **Do not** use any cleaning agents which contain chemicals.

Although the outer shell is tough and durable, there is a chance that it can be breached. Use care when docking or exposing the rubrail to conditions which may cause damage such as docking against heavily barnacle-encrusted pilings.

Some tears (cleanly sliced) can be repaired with a "Super Glue" type product.

Thoroughly clean and dry the affected area. Apply glue and hold the surfaces together.

Areas which have been torn or are affected by heavy abrasion will have to have the damaged section replaced. Please see your Boston Whaler dealer for this type of repair.

Cleaning Fiberglass and Non-Skid

To protect your deck and non-skid areas from the deteriorating affects of the sun, oxidation, water spots and pollution, use a good quality "fiberglass and non-skid deck" wax every two to three months.

When applied to your deck and non-skid areas, as recommended by the manufacturer, the wax forms a protective non-slick surface which will keep debris from sticking. Dirt, soot, bird droppings, and even fish blood will rinse right off.

NOTICE

Never use abrasive cleaners, detergents or soft scrub type cleaners to wash your boats surfaces.

Never use abrasive pads, brushes or sponges to attempt to remove stubborn stains.

Never use strong solvents or detergents which contain chlorine.

Stainless Steel Care

The cleaner your stainless trim and fittings can be kept, the greater the assurance of optimum corrosion resistance. Without proper care even the best stainless steel will corrode.

Stainless steel is strong and corrosion resistant, but still requires maintenance to keep its appearance. Frequent routine cleaning of your stainless steel with a mild soap and water solution and coating with a good grade cleaning wax will help maintain the finish.

- Wash with mild soap and cold or lukewarm water.
- Dry THOROUGHLY.
- Apply cleaning wax with a soft, dry cloth.
- Allow wax to dry, then polish and buff.

Even the finest cleaning powders can scratch or burnish a mill-rolled surface. On polished finishes, rubbing or wiping should be done in the direction of the polish lines, NOT across them.

Crevice corrosion, a brownish coloring which occurs where two pieces of stainless hardware meet is caused by impurities in water and air. It can be easily cleaned with a good grade marine polish using a sponge, cloth or small bristled brush (for nooks and crannies).

NOTICE

Never use abrasive cleaners, detergents or soft scrub type cleaners to wash your boats surfaces.

Never use abrasive pads, brushes or sponges to attempt to remove stubborn stains.

Never use strong solvents or detergents which contain chlorine.

Never use silver cleaners.

Teak Maintenance

The teak on this vessel requires some maintenance. Boston Whaler uses both natural teak and coated teak (pre-lacquered). Do not use a steel brush, steel wool, or a pressure washer on the wood. Do not use strong solvents or harsh cleaners on the caulking as these can damage or dissolve the caulk. Depending on the options selected for this vessel, different maintenance options apply:

Let-it-be (Natural Teak)

Left alone with the elements, teak changes to a silver-grey patina. To maintain, occasionally wash with soap and water. A light sanding every few years keeps the surface smooth; always sand with the wood grain.

Oiling

To retain or increase the darkness of the wood, apply a teak oil. There are numerous products on the market that provide a variety of different characteristics. Refer to the manufacturer's instructions for proper application.

Lacquering

Applying lacquer to teak may decrease the amount of maintenance required and reduces the risk of mold. Lacquers can be tinted to change the color of the finish and can be mixed with paint thinner

to reduce shine. Wood will likely darken when clear lacquer is applied. Carefully research product information to ensure it's suitable for both teak and caulk. Refer to the manufacturer's instructions for proper application.

Coated Teak (Pre-Lacquered)

If this vessel has a coated (pre-lacquered) table(s), keep covered when not in use. Be sure to allow for air flow between the table and the cover by inserting a non-marring object between the two. Refer to the manufacturer's instructions for proper care.

Seats (Mechanical Parts)

Always wash metallic parts with soap and water and rinse thoroughly with fresh water. Once dry, apply a light coating of lubricant to protect moving parts.

Check for loose or damaged hardware and tighten or replace as necessary.

Aluminum Care

Preventative maintenance is essential to life of the metals on your boat. The presence of salt particles and moisture is the major cause of white spots, pitting and corrosion.

The use of harsh chemicals can also cause deterioration. Manufacturers and applicators of protective coatings will not warrant protective coatings on metals in the marine environment. Proper owner maintenance is required to reduce deterioration which will result in most cases by failure to wash down and wipe dry after each use and/or the use of abrasive, acidic or other improper cleaners.

Wash completely using a soft cloth and mild detergent to remove salt particles. Hosing alone will not dislodge all particles. Do not allow soap to dry as it may cause stains on coated surfaces. Make sure to wash and dry the full circumference of aluminum parts.

Apply an aluminum protectant at least twice each year, more frequently as conditions warrant. Neglect will cause pitting of the surface which cannot be reversed.

Inspect and repair or replace all damaged nylon bushings, washers or other hardware designed to prevent contact with dissimilar metals.

Whenever electrical or electronic changes are made to the boat, a qualified marine technician should check aluminum parts for stray currents. Make sure all electronic equipment is properly grounded with adequate sized wire.

Whenever electrical or electronic changes are made to the boat, a qualified marine technician should check aluminum parts for stray currents. Make sure all electronic equipment is properly grounded with adequate sized wire.

Cushions

Saltwater, salt residue, dirt, ultra-violet rays etc. will take their toll on vinyl products causing them to lose their luster and texture.

The cushions on your boat are made of a durable vinyl material called OMNOVA which is protected by a finish called PreFixx[®]. PreFixx[®] will keep your cushions looking new far longer than most other vinyl upholstery.

To Clean Your Cushions

CAUTION

Solvents are flammable. Exercise proper care. Wear rubber gloves during all cleaning activity.

Use caution when cleaning around buttons, stitching and wooden or decorative trim as these solvents could seriously damage such areas.

- **Remove ordinary dirt and smudges** with a mild soap and water solution. Dry with a soft, lint-free cloth or towel.
- **More difficult stains** can be cleaned using rubbing alcohol (isopropyl alcohol). Rinse cleaned area with fresh water and dry with a clean, soft, lint-free cloth or towel.
- **Seemingly permanent stains** like ballpoint ink can be cleaned with active solvents such as nail polish remover when applied with a soft cloth or damp sponge and rubbed. Rinse

cleaned area with fresh water and dry with a clean, soft, lint-free cloth or towel.

The vinyl material and superior finish has been tested to resist heavy abrasion. Complete cleaning instructions are included in the owner's packet. Read all information provided by the cushion manufacturer regarding the proper cleaning and maintenance.

Your cushions are not waterproof. They are constructed of open-cell foam and will absorb and hold water. The foam is wrapped with a plastic barrier which helps to keep water from being absorbed into the foam but also will not allow water to dissipate once the foam is soaked. **Do not leave the cushions in standing water or exposed to heavy, prolonged rain.**

If, in the event your cushions become waterlogged, remove the foam from the cushion, press as much water as you can from the foam and allow to air dry. Make sure the plastic wrap is dry before wrapping the foam and inserting it back into the cushion.

To prevent mildew, keep the vinyl dry and make sure that moisture does not accumulate between the cushions.

Cleaning Your Instrument Gauges

When gauges are exposed to a saltwater environment, salt crystals may form on the bezel and plastic covers. Remove the salt crystals with a soft damp cloth. Clean with a mild household detergent or plastic cleaner.

Never use abrasives or rough, dirty cloths to clean plastic parts. A mild household detergent or plastic cleaner should be used. Wipe clean with a damp chamois.

FOR MORE INFORMATION, CONTACT MERCURY MARINE CUSTOMER SERVICE AT 1-920-929-5040

Powder Coated Surfaces

Your boat may have been manufactured with a powder coating on the optional T-top frame and or tow arch. While most powder coat finishes are tougher and much more flexible than conventional solvent based paints, they are about the same hardness as automotive paint, so they will scratch. To clean a powder coated surface, gently wash with a clean,

soft cloth and a mild detergent followed by a clear water rinse. Even though most powder coatings are highly resistant, certain solvents can harm them and should be avoided. Do not apply:

- Nail polish remover
- Paint or lacquer thinner
- Motor oils
- Transmission or brake fluids
- Parts cleaning fluids

If any of the above should contact the powder coated surface, immediately wipe the area with a soft, clean cloth, and wash as described above.

Powder Coating Touch-Up

If it is necessary to apply touch-up paint on areas of the finish that have been scratched or damaged the powder material supplier should be contacted for their recommendation of the proper touch-up material to use.

Single component Acrylic Enamel (spray enamel) touch-up paint is commonly used for repair of minor damage in the powder coated finish. In some cases a two-component catalyzed paint system may be required to achieve the desired repair. In all cases, perform a color and adhesion test in an inconspicuous area of the finish to assure compatibility before applying the paint to the damaged area.

NOTICE

For the best results, use Orbit Industries touch-up paint, RAL 9010 Pure White.

Orbit Industries: 1-800-448-3885

Touch-up Procedure

- CLEAN surface of dirt, oil, grease, etc.
- SAND LIGHTLY with 400 grit wet/dry abrasive paper.
- REMOVE sanding dust with a lint-free cloth dampened with mineral spirits.
- TEMPERATURE of surface and paint must be at room temperature (between 70 to 90 degrees is ideal).

- APPLY paint to minor scratches by spraying a small amount of paint into the container's cap. Using a small brush, carefully apply the paint sparingly to the properly prepared surface. Do not apply a heavy coat all at once. Apply several light coats allowing the paint to dry until tacky between each coat.

NOTICE

The visual, mechanical, chemical as well as corrosion protective and weather resistance properties of repaired areas ARE NOT equal to those of the original powder coating and are not suitable for long term performance.

NOTICE

If painting over exposed or bare metal, a chemical pretreatment process and/or primer sealer is recommended.

Follow manufacturer's recommendations.

NOTICE

It is highly recommended that you Do not penetrate the powder coating on your boat by securing equipment or other objects onto the coated surface. If necessary, contact the manufacturer for repair recommendations.

FOR MORE INFORMATION, CONTACT APEX POWDER COATING, INC CUSTOMER SERVICE AT 1-864-288-2739

Canvas Care and Maintenance

NOTICE

Do not use detergents, bleach or solvents to clean your canvas.

To keep your canvas and metal parts in good working condition and in good appearance, you will need to keep them clean.

The fabric should be cleaned regularly before substances such as dirt, pollen, etc. are allowed to accumulate on and become embedded in the fabric.

Maintaining a good appearance

- After each use, especially if used in salt water areas, rinse the canvas completely with fresh cold water.

On a regular basis

- Brush off any loose dirt, pollen, etc.
- Hose down with fresh cold water and clean with a mild solution of a natural soap in lukewarm water (maximum 100°F / 38°C).
- Allow the canvas to soak. Do not allow the soap to dry.
- Rinse thoroughly with fresh water.
- Let the canvas dry completely. Do not store any of the canvas pieces while wet.

The effects of ultraviolet light can sometimes be reduced by chemical treatment of canvas items.

Consult your Boston Whaler dealer or check your canvas manufacturer's manual **BEFORE** using any chemical treatments on your canvas.

Cleaning Stubborn Stains

Soak fabric for approximately twenty minutes in a mild solution consisting of no more than 1/2 cup (4 oz.) of bleach and 1/4 cup (2 oz.) of natural soap per gallon of lukewarm water (not to exceed 100° F / 38° C).

Rinse thoroughly in cold water several times. Allow the fabric to air dry completely.

NOTICE

Failure to remove all of the soap solution can cause deterioration of seams and prevent fabric from proper retreating.

Retreat the fabric using an air curing product such as 303 High Tech Fabric Guard to ensure water and stain repellency.

All canvas should be stored flat or rolled in a clean, dry space.

Maintaining Zippers and Hardware

Lubricate zippers and fasteners periodically with a clear silicone spray. In the absence of silicone spray, a wax candle can be used to lubricate the zipper track.

Replace any missing fasteners or any fasteners showing signs of corrosion.

NOTICE

Do not use petroleum based products, such as petroleum jelly, on the zippers or fasteners.

Maintaining Your Vinyl Windows

The canvas on your boat may incorporate Eisenglass or Makrolon® polycarbonate windows. In either case, with a few care and cleaning steps your windows will provide lasting enjoyment. Regular cleaning, utilizing compatible cleaners, coupled with proper maintenance techniques will significantly improve the vinyl's service life.

NOTICE

- **Never use regular window cleaners, detergents, abrasives, petroleum based products, or alcohol to clean your vinyl windows.**
- **Do not handle vinyl with sunscreen on your hands! Sunscreen will permanently cloud the vinyl where handled.**
- **Do not fold vinyl. Store flat or rolled with smooth paper or soft cloth (i.e. bed sheet) between layers when dry.**

- Rinse vinyl thoroughly with clear water to remove any dust, dirt particles, salt water or environmental agents before applying cleaning products.

This should be done frequently to avoid build up of salt water, dirt and other environmental contaminants.

- Using a soft non-abrasive cloth, wash windows inside and out with a mild soap (Woolite, Joy, Palmolive, etc.) and water solution. Rinse completely with cool water.

Do not use detergents.

- Use separate clean, soft cloths or sponges for application of cleaners and polishes (Use the manufacturer's recommended products).
- Use a small amount of cleaner or streaking may occur.

If you get streaking or a leftover film, follow up the application with a water rinse.

- Dry with a soft cloth or chamois to prevent water spots. Polish with a separate cloth.
- Don't leave cleaners on for long periods; wash immediately.
- Don't apply cleaners in direct sunlight or at elevated temperatures.
- Don't use scrapers, squeegees, razors, brushes, or towels.

Using a soft non-abrasive cloth, wash the vinyl curtains inside and out with mild soap and water mixture. **RINSE COMPLETELY** with cool water.

To minimize fine or hairline scratches apply a mild automotive polish (i.e. Johnson's Paste Wax) and remove with a soft, clean cloth. Do not use abrasive plastic polishes.

Storing Clear Vinyl

The clear vinyl should never be folded or creased as cracking will result. The recommended method of storage is to roll or lay the panels down flat. To protect the clear vinyl from rubbing against itself while rolled or stored flat, place a piece of very soft, nonabrasive cloth between the pieces.

NOTICE

Do not use solvents such as acetone, silicone spray, benzine, carbon tetrachloride, fire extinguisher fluid, dry cleaning fluid, lacquer thinner, glass cleaning solution or harsh detergents on acrylic.

The above substances will attack the surface of the vinyl.

NOTICE

Never use a dry cloth or duster or glass cleaning solutions on acrylic.

Cleaning Tempered Glass Windshield

NOTICE

Do not use abrasives, harsh chemicals or metal scrapers on glass.

NOTICE

For windshields with aluminum frames refer to *Aluminum Care* in this section.

Use commercially available glass cleaners or a mixture of fresh water and vinegar to clean your glass windows, windshield or port lights. Dry with a soft terry cloth towel or chamois.

Solid Surface Countertops

Following the guidelines below will keep your Corian surface looking as new as the day it was installed.

Routine Care

Soapy water, ammonia-based cleaners or commercial solid surface cleaners, if used routinely, will remove most dirt and residue from the countertop.

Minor Cuts and Scratches

Rub the scratch in a straight line with a fine grit sand paper periodically switch rubbing direction 90 degrees until all of the scratch is removed. Rinse top with water. Select the next lighter grit paper and rub over a large area to blend in the sanding. Continue the process using successively finer grits until desired gloss level is achieved. Wipe surface with damp cloth and let dry.

Heat Damage

Corian has excellent heat resistant properties. However, as with all countertop materials, it is important to minimize direct exposure to intense heat. We recommend the use of trivets or hot pads when

placing hot objects on the countertop.

Other Damage

In most cases, Corian can be repaired if accidentally damaged. However, to prevent any permanent damage to your countertop avoid exposing the surface to strong chemicals, such as paint removers, oven cleaners, nail polish remover, etc. If contact occurs quickly flush the surface with water. Avoid cutting directly on the countertop.

Refurbishing

Over time and use your countertop may acquire a patina, changing the appearance of the finish. Using a general countertop polish rub the entire surface in a circular motion, rinse with clear water and wipe dry.

Long Term Storage & Winterization

Long periods of storage, winter lay-up and/or non-use, common to boats, create unique problems. When preparing to store a boat for extended periods of two months or more it is best to make sure that the boat and its systems are properly conditioned for such extended periods of non-usage.

The guidelines presented on the following pages give basic instructions on “winterizing” your boat and boat systems. If inexperienced with the process of winterization it is best to hire the services of a professional.

In addition, always consult the owner’s manuals of the various systems and equipment on your boat for the manufacturer’s recommendations on winterizing and long term storage.

Engine

CAUTION

Never start or run your outboard (even momentarily) without having water circulating through the cooling water intake holes in the gear case. This will prevent damage to the water pump (running dry) or overheating of the engine.

Protecting your engine’s vital moving parts from corrosion and rust caused by freezing of trapped water or excessive condensation due to climatic

changes is very important. Freezing water in the engine can cause extensive damage to the internal moving parts. Internal engine parts can also be affected by rust due to lack of proper lubrication

- Replace engine oil and filter; run engine to drain as much old oil as possible.
- Flush engine with fresh water using flush muffs or a similar device attached to raw water pickup.
- Let all water drain from engine.
- Fog engine while it is running; spray until it stalls.
- Run fuel which has been treated with conditioner and stabilizer through engine.
- Replace lower unit gear oil. Check for moisture in old oil, a sign of deteriorating seals.
- Remove prop and grease shaft and threads.
- Treat all grease fittings with the recommended lubricant.
- Lightly lubricate the exterior of the engine or polish with a good wax.
- Check engine mount bolts. Ensure that they are torqued to 55 ft/lbs.

In addition, it is important that you follow all the recommendations set by the engine manufacturer’s operation manual.

Fuel System

NOTICE

Pay particular attention to the information provided in “Ethanol-Blended Fuel” in section 3 of this manual.

Tank(s), hoses, and fuel pumps should be treated to help prevent the formation of varnish and gum. Temperature extremes causes condensation to accumulate in an empty or partially filled fuel tank leading to fuel contamination and/or premature wear of your system. Fill the tank completely full and add fuel stabilizer and conditioner, following the manufacturer’s recommendations, to provide fuel stability and corrosion protection.

Battery

NOTICE

Follow the manufacturer's recommendations for long term storage of your battery(s).

Engine and house electrical systems on our boats have become increasingly more complex and are reliant on a good source of power. The house source of power typically comes from a battery bank comprised of two or three batteries in parallel. The charging source for the batteries while away from the dock is the engines; or if equipped a generator a generator and the generator is on, battery chargers. As the engines/generator are providing a charge output to the house bank through the automatic charging relays (ACRs), keep in mind the following battery recommendations.

Mixing Fresh/New and Used/Dead Batteries

The fresh battery will deliver current into a dead battery which has high resistance. This results in excessive heat in the used/dead battery, which can cause further damage, leakage, or rupture. A used battery will drain energy from the new one, reducing the total amount of battery power available.

Mixing Battery Types

Different battery types are designed for different purposes. Mixing an AGM battery with a lead acid battery will not improve performance. This results in reduced performance, may damage your devices, or cause battery leakage or rupture.

Mixing Battery Brands

Different battery brands may not have the same specifications like marine cranking amps (MCA) or cold cranking amps (CCA). This results in excessive heat, which may then cause damage, leakage or rupture in one of the batteries. We recommend using the same type of batteries throughout a boat.

NOTICE

Remove battery from boat and store in a cool, dry location. Periodically check the battery during storage.

- Disconnect the battery cables (negative cable first).
- Remove the battery from the boat.
- Clean the terminal ends of the cables and battery terminals with a solution of baking soda and water. Rinse thoroughly with clean water.
- Apply a coat of grease on the terminal ends of the cables and the battery terminals.
- Store the battery in a cool, dry area.
- Use a trickle charger to keep the battery charged or charge the battery every 30-60 days.

Livewell/Raw Water System

Drain the livewell. Ensure that all water is removed from the drain hose.

Remove the fill hose from the pump in the bilge and drain the water from the hose. Replace the hose on the pump and tighten the two clamps.

Fresh Water System

If the water system will not be used for an extended amount of time it is recommended that it be drained.

- Energize the freshwater pump switch on the instrument panel.
- Open all faucets and wash-down connections. Activate any sprayers connected to the system.
- Run the system until the fresh water tank is completely empty.
- De-energize the freshwater pump switch on the instrument panel.
- Add a non-toxic antifreeze to the water tank per manufacturer's recommendations.
- Energize the freshwater pump switch on the instrument panel.
- Run the system until antifreeze is seen running out of all faucets, wash-down connections and sprayers.

Chapter 5 • Care & Maintenance

- Close all faucets, wash-down connections and sprayers.
- De-energize the freshwater pump switch on the instrument panel.

If a water heater is a part of the system, isolate the tank by disconnecting the in and out hoses and connecting them together. Make sure that the tank contains a sufficient amount of non-toxic antifreeze to avoid freezing and causing damage.

After Long Term Storage

Before you fill the freshwater system it is vital that it be properly disinfected.

The following procedure is recommended to disinfect the freshwater system:

- Flush the entire system thoroughly by allowing potable water to flow through it.
- Drain the system completely.
- Fill the entire system with an approved disinfecting solution (check with your dealer for recommendations) and follow the method prescribed by the manufacturer.
- After disinfecting, drain the entire system.
- Flush the entire system thoroughly several more times with potable water.
- Fill with potable water.

This should be done annually or before using the system if it has been laid up for an extended amount of time.

Head System

- Pump out the holding tank at an approved facility.
- Add fresh water to the bowl and flush several times while the holding tank is being pumped.
- Use cleaning/sanitizing crystals or liquid, following manufacturer's recommendations, and let soak for a few minutes.

- Add fresh water and flush several times while pumping out holding tank again.
- Add antifreeze and flush/fill entire system.

Air Handling System

Follow manufacturer's recommendations for winterization/long term storage. The manufacturer's owner's manual can be found in your owner's manual packet.

Sump

Drain all water from sump. Remove the top and using a rag, clean up any residual water.

- Check all connections and tighten if necessary.
- Spray all connections with an anti-corrosion spray.

Electrical System

- Check all connections and tighten if necessary.
- Spray all connections with an anti-corrosion spray.

Deck

Clean the deck with soap, hot water and a stiff brush to clean up any oil spills.

Drainage

It is important to raise the bow of the boat enough to allow for proper drainage of water from the deck and bilge area. Make sure all the drainage fittings are clear and free of debris. Store the engine in an upright position to promote adequate drainage of water.

NOTICE

Ensure that ALL drain plugs are removed (i.e. fish boxes, garboard drain, livewells, etc.)

Avoid Loss

Remove any valuables or anything that can be easily removed from the boat such as electronics, lines, PFDs, fenders, cushions, etc. and store at home.

Cover

When covering your boat it is best to use a frame of either aluminum or wood to keep the cover up. This allows air to circulate and discourages water from pooling on the cover.

NOTICE

Do not use a bimini top in lieu of a cover. Damage and aging will occur while providing no protection for your boat.

Vents along the entire length of the cover will allow condensation to escape. Placing a series of foam pads between the hull and cover will also aid in air circulation and reduce condensation.

To help keep your boat dry and mildew free, consider placing commercial odor and moisture absorbing products in the boat under the cover.

Environment

Antifreeze and other winterizing fluids can be toxic to aquatic life and cause harmful effects to plant life.

Improper disposal of, or spillage of antifreeze and/or any winterization fluids can cause environmental problems when allowed to empty into waterways or

on the ground. Furthermore, it is illegal, punishable at minimum by fines.

Used antifreeze or any winterization fluids, should not be disposed of into sanitary sewers or publicly owned treatment plants.

Persons who have any questions regarding recycling antifreeze or other toxic fluids should write or call their state's EPA office.

Reinforcement Locations

Your boat has been manufactured with reinforcement in various locations throughout the deck.

In the event you wish to add equipment to your boat which requires you to penetrate the deck with fasteners, the diagram on the following page illustrates the size, location and type of the reinforcement available. The chart below provides a description of the material and recommended fasteners to secure your equipment.

CAUTION

Do not attempt to secure equipment in any location other than those that are illustrated.

Reinforcement	Construction	Equipment weight	Fastener Type*
Plywood	Standard boat building material	Light	Self-tapping screws
Trevira	Thick spunbound polyester fabric	Light	Sheet Metal screws
Sparalloy	High density plastic	Medium	Self-tapping screws
Phenolic**	Reinforced composite board	Heavy	Drill & Tap

* In all cases it is recommended to drill and countersink a pilot hole to prevent damage to the gelcoat surface.
**Also known as Whaleboard

Reinforcement Location Diagram

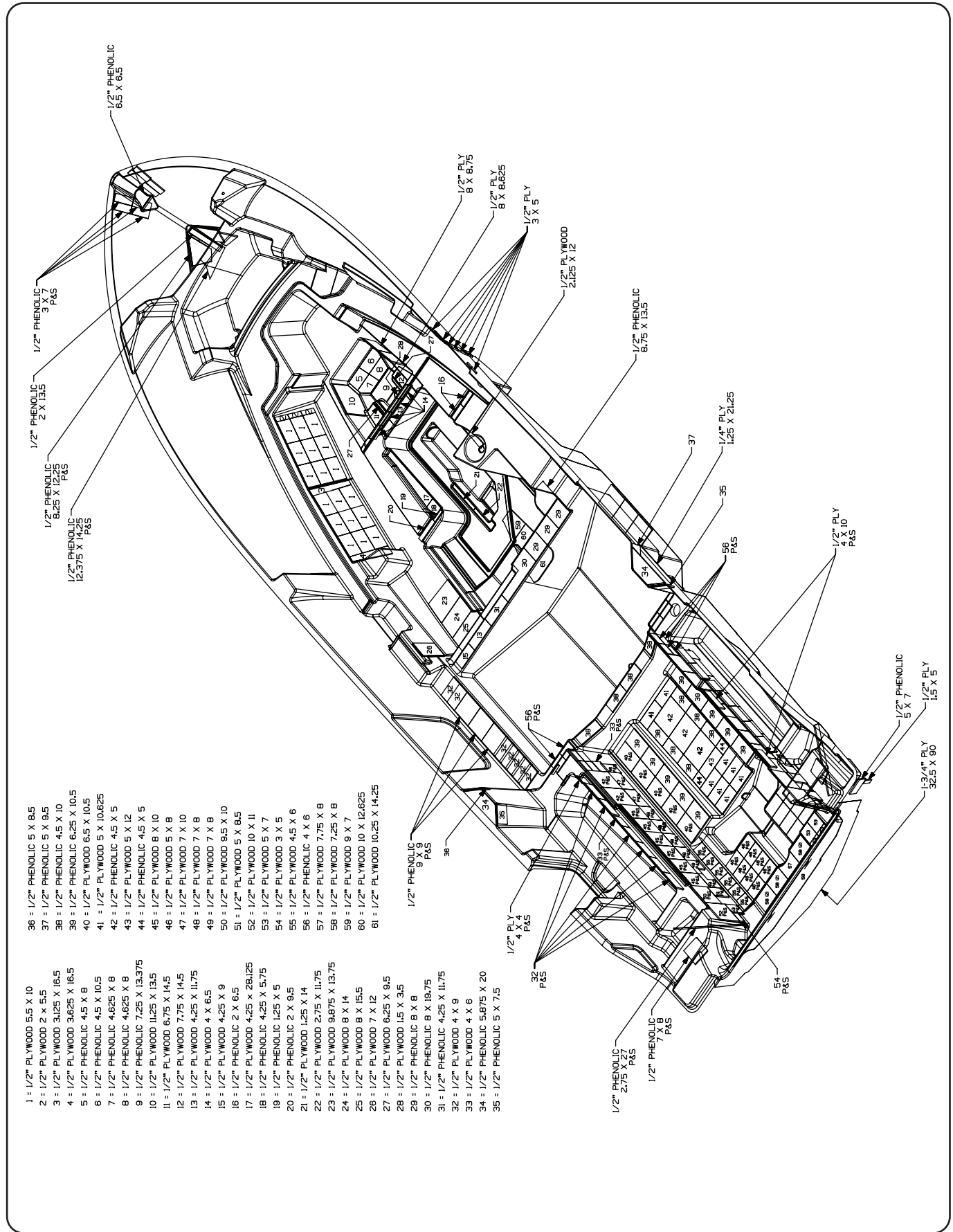

Chapter 5 • Care & Maintenance

Fill out the log below after scheduled service or maintenance is performed.

MAINTENANCE LOG			
DATE	ENGINE HOURS	SERVICED BY	MAINTENANCE PERFORMED

NOTES

THIS PAGE INTENTIONALLY LEFT BLANK