

405 Conquest
405 Pilothouse
Owner's Manual



THE UNSINKABLE LEGEND

405 Conquest



The mission of Boston Whaler® is to provide consumers with the safest, highest quality, most durable boats in the world.



WARNING

Operating, servicing and maintaining a recreational marine vessel can expose you to chemicals including engine exhaust, carbon monoxide, phthalates, and lead, which are known to the State of California to cause cancer and birth defects or other reproductive harm. To minimize exposure, avoid breathing exhaust, service your vessel in a well-ventilated area and wear gloves or wash your hands frequently when servicing this vessel. For more information go to www.P65warnings.ca.gov/marine.

Introduction



T H E U N S I N K A B L E L E G E N D™

Welcome to the Boston Whaler® family and congratulations on your purchase!

For over six decades, Boston Whaler has engineered the most reliable and forward-thinking boats on the water. Every chapter of our history starts with a belief in pushing the limits of what's possible, and this heritage is cause for both reflection and celebration.

Standing behind every Whaler is an extremely qualified network of dealers to provide you with a truly exceptional boating experience. Information and assistance is also available at bostonwhaler.com, where you will find customer resources including how-to videos, maintenance tips, and other technical content. While there, don't forget to sign up to receive future issues of Boston Whaler's lifestyle magazine, Whaler.

Since Boston Whaler's inception in 1958, we are committed to providing customers with the safest, highest-quality, most durable boats in the world. We are confident that as a Whaler owner you will love the quality and pride that is built into every boat.

From all of us here at Whaler, thank you for selecting one of our a legendary and innovative boats. May that choice bring you a lifetime of boating enjoyment.

Introduction

History

Since our founding, Boston Whaler® has conceived and built peerless designs that meet boaters' diverse and changing needs. It all began in Braintree, Massachusetts with founder Richard Fisher's inspired new construction method featuring two significant innovations: first, a twin-sponson hull design that resulted in superior stability and a remarkably dry ride, and second, a unique foam-core construction that made the boat not only durable, but unsinkable as well. So for people whose livelihood and lives depend on their boat, Boston Whaler is the right choice because of our seaworthiness, dependability, and the inherent safety of a hull that won't sink even if severely damaged. Plain and simple, Boston Whaler boats are built to last.

In 1961, Fisher's demonstration of that unsinkability was captured by *Life* magazine in photos showing a Whaler® boat being sawed in half and Fisher then motoring away in the remaining half. True to Fisher's vision, Boston Whaler's world-class team has consistently pushed the envelope, furthering advances in manufacturing, design, navigation, and propulsion technologies.

On September 26, 1996, Richard Fisher was posthumously inducted into the National Marine Manufacturer's Association (NMMA) hall of fame for accomplishments made in marine engineering and construction.



In 1958, the legend is born as company founder Dick Fisher demonstrates a Boston Whaler's total unsinkability.

Introduction

Table of Contents

Introduction

Welcome Letter	Intro-1
History	Intro-2
Preface	Intro-5
Limited Warranty (US/Canada)	Intro-6
Limited Warranty (Non-US/Canada)	Intro-11
CARB Warranty Statement	Intro-15
Privacy Statement	Intro-16
Owner's Packet	Intro-17
Contact Us.....	Intro-17
Boating Information	Intro-17

Chapter 1 • Safety

Safety Labels	1-1
Safe Boating	1-2
Maintaining Control	1-3
Impaired Operation	1-3
Operator Responsibility	1-4
Legally Mandated Equipment	1-5
Personal Flotation Devices (PFD's)	1-5
Fire Extinguishers	1-5
Sound-producing Devices	1-5
Visual Distress Signal	1-5
Carbon Monoxide (CO)	1-6
Carbon Monoxide Detector	1-6
Lifesaving Equipment.....	1-8
Emergency Situations	1-8
Water Rescue.....	1-9
Fire	1-9
Smoke Detector	1-10
Flooding, Swamping and Capsizing	1-10
Propulsion, Control or Steering Failure	1-11
Grounding	1-11
Distress Signals.....	1-11
Radio Communications	1-12
Weather	1-12
Swimming, Diving and Water Skiing.....	1-13
Engine Emergency Stop Switch	1-15
1st Mate™ Safety and Security System (Option)..	1-16
Float Plan	1-16
Environmental Considerations	1-17
Homeland Security Restrictions	1-17
America's Waterway Watch	1-17
Safety Label Locations	1-17
Key to Symbols	1-26

Chapter 2 • General Information

Construction Standards.....	2-1
Hull Construction.....	2-1
Hull Identification Number.....	2-1
Servicing	2-1
Manufacturer's Certification	2-2
Certification Plates.....	2-2
Certification Design Category	2-4
Power Capacity	2-3
Specifications and Dimensions.....	2-5
Deck Occupancy.....	2-7
Recommended Occupant Locations.....	2-8
Thru-hull Fitting Locations.....	2-9
Features	2-11
Deck.....	2-11
Bow Equipment	2-12
Helm	2-13
Cockpit Ice Maker	2-14
Helm Switch Panels	2-15
Footrests.....	2-16
Freshwater Showers	2-16
Transom	2-17
Hardtop	2-20
Navigation Lights.....	2-22
Mechanical Access Hatches	2-23
Cabin Salon.....	2-26
Cabin Panels and Displays	2-27
Stateroom.....	2-28
Head Controls	2-29
Canvas (Option)	2-30
Pilothouse (Option).....	2-31
Diesel Heater (Option)	2-31
Upper Station Helm (Option)	2-32

Chapter 3 • Systems Overview & Operation

Bilge Pumps.....	3-1
Aft Bilge.....	3-1
Forward Bilge	3-2
High Water Bilge	3-3
Fuel System	3-4
Theft Deterrent System (WhalerWatch).....	3-7
Throttle and Shift Control.....	3-8
Starting the Engines	3-9
Stopping the Engines.....	3-11
Bow Thruster	3-11
Joystick Piloting.....	3-12
Transfer Joystick Control	3-13

Introduction

VesselView.....	3-14
Trim Tabs.....	3-14
Power Steering System.....	3-16
Freshwater System.....	3-17
Raw Water System.....	3-20
Raw Water Washdown.....	3-22
Livewell.....	3-23
Head System.....	3-23
Waste System.....	3-24
Overboard Discharge of Waste.....	3-25
Macerator and Dockside Discharge.....	3-26
Air Conditioning.....	3-26
Water Heater.....	3-29
Engine Flush System (Option).....	3-30
Diesel Generator System.....	3-31
Start-up.....	3-32
Shutdown.....	3-35
Shore Power.....	3-36
Fire Suppression System.....	3-39
Manual Fire Override.....	3-41
Dive Door and Ladder.....	3-42
Fishbox with Pumpout Discharge.....	3-43
Refrigeration.....	3-44
Chiller/Freezer Plates (Option).....	3-45
Electric Reel/Downrigger Receptacle (Option).....	3-46
Cockpit Tables (Option).....	3-47
Salon Bed.....	3-48
Convertible Lounge.....	3-49
Pull-out Grill.....	3-52
Cooktop.....	3-53
Entertainment System.....	3-53
Outriggers (Option).....	3-54
Spotlight.....	3-55
Thermal Night Vision Camera (Option)....	3-55
Windshield Vent.....	3-55
Hardtop Skylight (Option).....	3-56
Electric Sun Shade.....	3-56
Bow Shade (Option).....	3-57
Lighting.....	3-57
Reboarding Ladder.....	3-58
Gyroscopic Stabilizer (Option).....	3-59
Propeller.....	3-60
Anchoring.....	3-60
Anchor Windlass.....	3-64
Towing, Docking, and Lifting.....	3-65
Out of Water Storage.....	3-67

Chapter 4 • Electrical

DC Electrical System.....	4-1
Batteries.....	4-1
Remote Battery Switches.....	4-2
Automatic Charging Relays.....	4-2
Ground Fault Circuit Interrupters.....	4-5
Component Breakers.....	4-6
AC Electrical System.....	4-7
Engine Breaker Boxes.....	4-8
Main DC Breaker Panel.....	4-9
Fuse Blocks.....	4-9
Electrical Components.....	4-12
Digital Switching.....	4-13
CZone Module.....	4-20
Transducer.....	4-21
Rigging Pulls.....	4-22
Schematics.....	4-23

Chapter 5 • Care & Maintenance

Routine Care and Maintenance.....	5-1
Hull.....	5-1
Aquatic Invasive Species (AIS).....	5-1
Waxing Gel Coat Surfaces.....	5-3
Sacrificial Anodes.....	5-3
Bottom Painting.....	5-3
Rubrails.....	5-4
Cleaning Fiberglass and Non-Skid.....	5-4
Stainless Steel.....	5-4
Teak.....	5-5
Seats (Mechanical Parts).....	5-5
Aluminum.....	5-5
Standard Vinyl Cushions.....	5-6
Cool Technology Vinyl Cushions (Option)...	5-6
Canvas.....	5-6
Vinyl Windows.....	5-7
Tempered Glass Windshield.....	5-7
Long-term Storage and Winterization.....	5-7
Engine.....	5-8
Fuel System.....	5-8
Freshwater System.....	5-8
Batteries.....	5-9
Reinforcement Locations.....	5-10

Introduction

Preface

READ AND RETAIN this manual. If the boat is sold, ensure all documentation is transferred to the new owner.

Information in this publication is based on the latest product specifications available at the time of printing. Boston Whaler reserves the right to make changes at any time without prior notice. Boston Whaler is not responsible for specification changes to parts or accessories manufactured by other companies.

NOTE: Equipment may vary depending on options selected.

If needed in connection with selling your boat, service history or warranty records on vessels should be requested from the original selling dealer, the servicing dealer and/or the previous owner (where applicable). Information regarding open safety recalls is maintained by the United States Coast Guard, and can be obtained by visiting uscgboating.org.

Brunswick Corporation registered trademarks: Mercury Marine, Mercury Racing, Optimax, Nautic-On, Skyhook, SmartCraft, Verado, Vantage, VesselView, VesselView Mobile.

Boston Whaler, Inc. registered trademarks: Boston Whaler, Boston Whaler with harpoon and hull logo, Conquest, Dauntless, Montauk, Outrage, Realm, Unibond, Whaler.

All other trademarks listed in this publication are the property of their respective owners.

BOSTON WHALER® • A BRUNSWICK COMPANY

© November 2020 Brunswick Corporation



BOSTON WHALER LIMITED MANUFACTURER WARRANTY (US AND CANADA)

Boston Whaler, Inc. (“Boston Whaler”) provides the following Limited Manufacturer Warranty to the original retail owner of its 2024 model year Boats, if purchased from an authorized Boston Whaler Dealer and operated under normal, non-commercial use, subject to the remedies, exclusions, and limitations set out below.

- 1. Ten-Year Structural Hull Limited Warranty:** Any Structural Hull Defect in material or workmanship which is reported within ten (10) years from the date of sale to the original retail owner will be repaired or replaced at Boston Whaler’s sole discretion. The “Hull” shall mean the single fiberglass molded shell and integral structural components. A Structural Hull Defect shall mean a substantial defect in the Boat’s Hull which causes the Boat to be unfit or unsafe for general use as a pleasure craft under normal operating conditions.
- 2. Three-Year Limited Warranty on Components Manufactured or Installed By Boston Whaler: (not applicable to 13 Super Sport or 16 Super Sport models):** Boston Whaler will repair or replace, at its sole discretion, any components manufactured or installed by Boston Whaler that are defective in factory materials and/or workmanship, which are reported within three (3) years from the date of delivery to the first retail purchaser, and are not addressed in the specific warranties listed in paragraphs 1 or 4 or set out in the Exclusions paragraph below.
- 3. One-Year Limited Warranty on Accessory Components for the 13 Super Sport and 16 Super Sport Models:** Boston Whaler provides the following Limited Warranty to the original retail owner of any factory-authorized accessory for the 2024 model year 13 Super Sport and 16 Super Sport, if purchased from an authorized Boston Whaler Dealer, authorized Boston Whaler website or any Boston Whaler affiliate and utilized under normal, non-commercial use (“Accessory”), subject to the remedies, exclusions, and limitations set out below. Boston Whaler will repair or replace, at its sole discretion, any Accessory that is defective in material or workmanship, which is reported within one (1) year from the date of delivery to the first retail purchaser. Boston Whaler is not responsible for any defect and/or damage to the Accessory and/or the Boat caused by improper installation, whether performed by the retail owner, dealer or any other third party.
- 4. One-Year Limited Warranty on Upholstered Items, Canvas, Teak, and Powder Coating:** Boston Whaler will repair or replace, at its sole discretion, any upholstered items, canvas, teak, and powder coating manufactured or installed by Boston Whaler that are defective in factory materials and/or workmanship and are reported within one (1) year from the date of delivery to the first retail purchaser.
- 5. Limited Engine Warranty:** Retail owners will be entitled to the limited engine warranty as provided in the warranty manual from the engine manufacturer that was delivered to the retail owner with his or her Boston Whaler Boat.

EXCLUSIONS

This Limited Manufacturer Warranty does not apply to any Boat which has been salvaged or declared a total loss or constructive total loss for any reason not covered in this limited warranty. This Warranty also does not apply to the following items:

- 1) Expenses for hauling out or transportation to and from the dealer or Boston Whaler factory for warranty service.
- 2) Equipment or accessories which are not installed by Boston Whaler or which carry their own individual warranties, including but not limited to engines, engine components, batteries, propellers, controls, steering mechanisms, and electronics.
- 3) Damage, deterioration, discoloration or mold of cushions or cosmetic surface finishes, including scratches, gouges, chips, chalking, blistering, cracking, crazing, fading or oxidation of gel coat, stress lines, plated or

painted metal and stainless steel finishes, plastics or acrylic materials, or anti-fouling bottom paint.

- 4) Windshield breakage and leakage.
- 5) Any Boat initially sold at retail by a party other than an authorized Boston Whaler dealer.
- 6) Damage resulting from abuse, misuse, improper rigging and installation by an owner or any other person or entity that is not an authorized dealer, accidents, or overloading or powering in excess of the recommended maximum horsepower.
- 7) Failure of the owner to use, maintain, or store the Boat as specified in the Boston Whaler owner's manual; and any other failure to provide reasonable care and maintenance. Normal wear and tear maintenance items are excluded from warranty coverage including but not limited to filters, bulbs, batteries, bungees, wiper blades, anchor rope, trailer finishes, tires, brakes, bearings, and lights.
- 8) Any Boston Whaler Boat which has been altered or modified from Boston Whaler factory specifications, including penetration of the hull by anyone other than Boston Whaler factory personnel or Boston Whaler authorized dealer service personnel following factory specified procedures.
- 9) Damages resulting from use of improper trailer, improperly placed supporting bunks or slings, incorrect bunks placement, or improper boat lift or sling.
- 10) Damages due to failure to properly tow the Boat. For those Boats for which Boston Whaler offers a yacht tender package, damages due to towing when the package has not been installed.
- 11) Any Boston Whaler Boat used for commercial purposes, which includes, but is not limited to, any for-profit or other revenue-generating uses.
- 12) Any representation or implication relating to speed, range, fuel consumption or estimated performance characteristics.
- 13) Any failure or defect caused by an act of nature resulting in damage, cost, or expense.
- 14) Any failure or defect arising from a previous repair made by a non-authorized service provider.
- 15) Any item exceeding the expressed coverage limits specified in any Boston Whaler Limited Manufacturer Warranty.
- 16) Failure of the owner to use, maintain, or store an Accessory in reasonable fashion; and any other failure to provide reasonable care and maintenance.
- 17) Any accessory which has been altered or modified from Boston Whaler factory specifications.
- 18) Any accessory not purchased from an authorized Boston Whaler Dealer, authorized Boston Whaler website, or authorized Boston Whaler affiliate. For a list of Boston Whaler's affiliates, please refer to www.brunswick.com.
- 19) Any accessory used for commercial purposes, which includes but is not limited to, any for-profit or other revenue generating uses.
- 20) Any defect or repair requiring redesign of the Boat, except pursuant to the recall provisions of the United States Federal Boat Safety Act of 1971 or the recall laws of any other foreign jurisdiction.

SOLE REMEDY

THE REMEDY OF REPAIR OR REPLACEMENT OF PARTS OR MATERIALS THAT ARE FOUND TO BE DEFECTIVE IN FACTORY MATERIALS OR WORKMANSHIP COVERED BY THIS LIMITED MANUFACTURER WARRANTY SHALL CONSTITUTE THE OWNER'S SOLE AND EXCLUSIVE REMEDY AGAINST BOSTON WHALER FOR ANY CLAIMS WHATSOEVER OF ECONOMIC LOSS RESULTING FROM PRODUCT FAILURE.

ENVIRONMENTAL POLICIES

In keeping with environmental policies and practices, Boston Whaler reserves the right to utilize reconditioned, refurbished, repaired or remanufactured products or parts in the warranty repair or replacement process. Such products and parts will be comparable in function and performance to an original product or part and warranted for the remainder of the original warranty period. In no event shall any repair or replacement under this Limited Manufacturer Warranty exceed the fair market value of the product as of the date of the owner's claim. Acceptance of any product returned or any refund provided by Boston Whaler shall not be deemed an admission that the product is defective. Products that are replaced become the property of Boston Whaler.

OTHER LIMITATIONS

EXCEPT AS SET FORTH HEREIN, THERE ARE NO OTHER WARRANTIES, EITHER EXPRESS OR IMPLIED, PROVIDED BY BOSTON WHALER ON THIS BOAT. ALL OTHER WARRANTIES, EXPRESS OR IMPLIED, INCLUDING IMPLIED WARRANTIES OF FITNESS AND MERCHANTABILITY, ARE EXPRESSLY EXCLUDED. BOSTON WHALER FURTHER DISCLAIMS ANY LIABILITY FOR ECONOMIC LOSS ARISING FROM CLAIMS OF PRODUCT FAILURE, NEGLIGENCE, DEFECTIVE DESIGN, MANUFACTURING DEFECT, FAILURE TO WARN AND/OR INSTRUCT, LACK OF SEAWORTHINESS, AND ANY OTHER THEORY OF LIABILITY NOT EXPRESSLY COVERED UNDER THE TERMS OF THIS LIMITED MANUFACTURER WARRANTY.

ANY IMPLIED WARRANTY OF MERCHANTABILITY OR FITNESS FOR A PARTICULAR PURPOSE IS DISCLAIMED. TO THE EXTENT THE IMPLIED WARRANTY CANNOT BE DISCLAIMED, IT IS LIMITED TO THE SHORTER OF ONE YEAR FROM THE DATE OF DELIVERY TO THE FIRST RETAIL OWNER OR THE DURATION OF THE RESPECTIVE EXPRESS LIMITED WARRANTIES STATED HEREIN. TO THE EXTENT ALLOWED BY LAW, NEITHER BOSTON WHALER, NOR THE SELLING DEALER, SHALL HAVE ANY RESPONSIBILITY FOR LOSS OF THE BOAT, LOSS OF TIME, INCONVENIENCE, COMMERCIAL LOSS OR CONSEQUENTIAL DAMAGES. SOME STATES DO NOT ALLOW LIMITATIONS ON HOW LONG AN IMPLIED WARRANTY LASTS, SO THE ABOVE LIMITATION MAY NOT BE APPLICABLE. SOME STATES DO NOT ALLOW THE EXCLUSION OR LIMITATION OF INCIDENTAL OR CONSEQUENTIAL DAMAGES, SO THE ABOVE LIMITATIONS OR EXCLUSIONS MAY NOT BE APPLICABLE. THIS WARRANTY GIVES THE OWNER SPECIFIC LEGAL RIGHTS, AND THE OWNER MAY ALSO HAVE OTHER RIGHTS WHICH VARY FROM STATE TO STATE OR COUNTRY TO COUNTRY.

STATUTE OF LIMITATIONS

Any action for rescission or revocation against Boston Whaler shall be barred unless it is commenced within one (1) year from the date of accrual of such cause of action. This provision does not grant any consumer a right of rescission or revocation against Boston Whaler, where such right does not otherwise exist under applicable law. Some states may not allow the applicable statute of limitations for rescission or revocation to be reduced, so this provision may not apply to each retail owner.

OWNER'S OBLIGATIONS

To initiate a warranty claim, it is the responsibility of the owner to contact an authorized Boston Whaler dealer immediately after discovery of any defect, describe the nature of the problem, and provide a hull serial number, date of purchase, and name of selling dealer. The authorized dealer will notify Boston Whaler, who is solely responsible for determining and authorizing in writing the remedial action(s) to be performed at

either an authorized Boston Whaler dealership chosen by Boston Whaler or at the Boston Whaler factory. The owner should notify Boston Whaler of any Boat being repaired by an authorized Boston Whaler dealer which has been at the dealership for fifteen (15) days, or of any claimed defect which was not corrected after one repair attempt. The owner must provide Boston Whaler with a reasonable opportunity to repair, and reasonable access to the Boston Whaler Boat for warranty service and the owner shall pay for all related transportation charges and/or travel time. If the owner cannot deliver the product to such a dealer, written notice must be given to Boston Whaler. Boston Whaler will then arrange for the inspection and any covered repair and the owner shall pay for all related transportation charges and/or travel time. Our privacy policies are available at www.bostonwhaler.com.

ASSIGNMENT OF COMPONENT WARRANTIES

Except as expressly set out herein, all warranties provided by the manufacturers and distributors of components, equipment, and parts on the Boat (collectively “Component Manufacturers”) are hereby assigned to the owner to the extent permitted by the Component Manufacturers, as the owner’s sole and exclusive remedy with respect to such items.

REGISTRATION & WARRANTY TRANSFER POLICY

The limited warranty coverage is activated by the authorized selling dealer registering the sale of a new Boat with Boston Whaler.

The Ten-Year, Three-Year, and One-Year limited warranties are transferable to a subsequent owner, except the one-year Accessory warranty which is not transferrable and this Limited Manufacturer Warranty will not transfer to any new owner of a Boat which has been salvaged and resold, or resold after a declaration of a total loss or a constructive total loss, i.e., the cost of repair exceeds the value of the Boat. The new owner must fill out and submit the online Boston Whaler warranty transfer form, accessible from www.bostonwhaler.com. A copy of the bill of sale will be required to submit with the form. The warranty transfer must be completed within 30 days of purchase. Notwithstanding anything in this Limited Manufacturer Warranty to the contrary, Boston Whaler reserves the right to reject any warranty transfer request for a Boston Whaler Boat that has been damaged, neglected, or otherwise previously excluded from warranty.

MODIFICATIONS & SEVERABILITY

The terms and conditions contained herein, as well as those of any documents prepared in conjunction with the sale of this vessel may not be modified, altered or waived by any action, inaction, or representations, whether oral or in writing, except upon the expressed, written authority of a management level employee of Boston Whaler. The invalidity or unenforceability of any one or more of the provisions herein shall not affect the validity and enforceability of the other provisions.

GOVERNING LAW AND VENUE

This Warranty shall be interpreted and construed according to and governed by the laws of the State of Tennessee, without regard to conflict of law principles. Venue for any and all disputes arising out of or related to this Warranty, including without limitation the interpretation, performance or breach of this Warranty, shall be solely and exclusively before the United States District Court for the Eastern District of the State of Tennessee. The parties consent to the in *personam* jurisdiction of said court for the purposes of any such litigation and waive, fully and completely, any right to dismiss and/or transfer any action pursuant to 28 U.S.C. Section 1404 or 1406 (or any successor statutes) or the doctrine of *forum non conveniens*. If the United States District Court does not have subject matter jurisdiction of said matter, then such matter shall be litigated solely and exclusively before the appropriate state court of competent jurisdiction located in Knox County, Tennessee, and the parties consent to the personal jurisdiction of such court for the purpose of such litigation.



SAFETY

It is your responsibility (as well as the responsibility of any other operator of this Boat) to be familiar with and observe all local, state and federal laws, rules and regulations regarding boating, navigation and boating safety. You and any other operator of this Boat should take a course in boating and boating safety before operation of this Boat and should be completely familiar with all systems regarding safe operation of this Boat. Personal flotation devices should be worn by each passenger in accordance with U.S. Coast Guard standards and state and federal law.

World Headquarters
100 Whaler Way, Edgewater, FL 32141
(386) 428-0057
bostonwhaler.com

BOSTON WHALER LIMITED MANUFACTURER WARRANTY (Outside the U.S. or Canada)

Boston Whaler, Inc. (“Boston Whaler”) provides the following Limited Manufacturer Warranty to the original retail owner of its 2024 model year Boats, that if purchased from an authorized Boston Whaler dealer and operated under normal, non-commercial use, the authorized dealer will repair or replace, at its sole discretion, any defect in material or workmanship in the Boston Whaler Boat that is reported within the applicable Limited Manufacturer Warranty periods and within the scope as set out below.

Mandatory warranty rights, including a consumer’s mandatory statutory rights, by law are not affected by this Limited Manufacturer Warranty and in particular not limited or excluded. These mandatory legal rights exist regardless of whether a warranty claim occurs or rights are asserted under this Limited Manufacturer Warranty.

SCOPE

This Limited Manufacturer Warranty applies only to Boston Whaler Boats purchased outside of the US and Canada, including the territory of the European Union and Australia, and to recreational use customers only (not commercial users). Commercial use, which voids the Limited Manufacturer Warranty, is defined as any use of the product which generates income, even if the product is only occasionally used for such purposes.

Routine maintenance outlined in the Operation and Maintenance Manual must be timely performed in order to maintain Limited Manufacturer Warranty coverage.

This Limited Manufacturer Warranty applies to the following items:

- 1. Ten-Year Structural Hull Limited Warranty:** Any Structural Hull Defect in material or workmanship which is reported within ten (10) years from the date of sale to the original retail owner will be repaired or replaced at Boston Whaler’s sole discretion. The “Hull” shall mean the single fiberglass molded shell and integral structural components. A Structural Hull Defect shall mean a substantial defect in the Boat’s Hull which causes the Boat to be unfit or unsafe for general use as a pleasure craft under normal operating conditions.
- 2. Three-Year Limited Warranty on Components Manufactured or Installed By Boston Whaler (not applicable to 13 Super Sport or 16 Super Sport models):** Boston Whaler will repair or replace, at its sole discretion, any components manufactured or installed by Boston Whaler that are defective in factory materials and/or workmanship, which are reported within three (3) years from the date of sale to the original retail owner, and are not addressed in the specific warranties listed in paragraphs 1 or 4 or set out in the Exclusions paragraph below.
- 3. One-Year Limited Warranty on Accessory Components for the 13 Super Sport and 16 Super Sport Models:** Boston Whaler provides the following Limited Warranty to the original retail owner of any factory-authorized accessory for the 2024 model year 13 Super Sport and 16 Super Sport, if purchased from an authorized Boston Whaler Dealer, authorized Boston Whaler website or any Boston Whaler affiliate and utilized under normal, non-commercial use (“Accessory”), subject to the remedies, exclusions, and limitations set out below. Boston Whaler will repair or replace, at its sole discretion, any Accessory that is defective in material or workmanship, which is reported within one (1) year from the date of sale to the original retail owner. Boston Whaler is not responsible for any defect and/or damage to the Accessory and/or the Boat caused by improper installation, whether performed by the retail consumer, dealer or any other third party.
- 4. One-Year Limited Warranty on Upholstered Items, Canvas, Teak, and Powder Coating:** Boston Whaler will repair or replace, at its sole discretion, any upholstered items, canvas, teak, and powder coating manufactured or installed by Boston Whaler that are defective in factory materials and/or workmanship and are reported within one (1) year from the date of sale to the original retail owner.

5. Limited Engine Warranty: Retail owners will be entitled to the limited engine warranty as provided in the warranty manual from the engine manufacturer that was delivered to the original retail owner with his or her Boston Whaler Boat.

EXCLUSIONS

This Limited Manufacturer Warranty does not apply to any Boat which has been salvaged or declared a total loss or constructive total loss for any reason not covered in this limited warranty. This warranty also does not apply to the following items:

- 1) Expenses for hauling out, transportation to and from the dealer or the Boston Whaler factory for warranty service.
- 2) Equipment or accessories which are not installed by Boston Whaler or which carry their own individual warranties, including but not limited to engines, engine components, batteries, propellers, controls, steering mechanisms, and electronics.
- 3) Damage, deterioration, discoloration or mold of cushions or cosmetic surface finishes, including scratches, gouges, chips, chalking, blistering, cracking, crazing, fading or oxidation of gel coat, stress lines, plated or painted metal and stainless steel finishes, plastics or acrylic materials, or anti-fouling bottom paint.
- 4) Windshield breakage and leakage.
- 5) Any Boston Whaler Boat initially sold at retail by a party other than an authorized Boston Whaler dealer.
- 6) Damage resulting from abuse, misuse, improper rigging and installation by an owner or any other person or entity not being an authorized dealer, accidents, overloading or powering in excess of the recommended maximum horsepower.
- 7) Failure of the owner to use, maintain, or store the Boat as specified in the Boston Whaler owner's manual; and any other failure to provide reasonable care and maintenance. Normal wear and tear maintenance items are excluded from warranty coverage including but not limited to filters, bulbs, batteries, bungees, wiper blades, anchor rope, trailer finishes, tires, brakes, bearings and lights.
- 8) Damages due to failure to properly tow the Boat. For those Boats for which Boston Whaler offers a yacht tender package, damage due to towing when the package has not been installed.
- 9) Any Boston Whaler Boat which has been altered or modified from Boston Whaler factory specifications, including penetration of the hull by anyone other than Boston Whaler factory personnel or Boston Whaler authorized dealer service personnel following factory specified procedures.
- 10) Damage resulting from use of improper trailer, improperly placed supporting bunks or slings, incorrect bunks placement and improper Boat lift or sling.
- 11) Any Boston Whaler Boat used for commercial purposes, which includes, but is not limited to, any for-profit or other revenue-generating uses.
- 12) Any representation or implication relating to speed, range, fuel consumption or estimated performance characteristics.
- 13) Any failure or defect caused by an act of nature resulting in damage, cost, or expense;
- 14) Any failure or defect arising from a previous repair made by a non-authorized service provider.
- 15) Any item exceeding the expressed coverage limits specified in any Boston Whaler Limited Manufacturer Warranty.
- 16) Failure of the owner to use, maintain, or store an Accessory in reasonable fashion; and any other failure to provide reasonable care and maintenance.
- 17) Any Accessory which has been altered or modified from Boston Whaler factory specifications.
- 18) Any Accessory not purchased from an authorized Boston Whaler Dealer, authorized Boston Whaler

website, or authorized Boston Whaler affiliate. For a list of Boston Whaler's affiliates, please refer to www.brunswick.com.

19) Any Accessory used for commercial purposes, which includes but is not limited to, any for-profit or other revenue generating uses.

20) Any defect or repair requiring redesign of the Boat, except pursuant to the recall provisions of the United States Federal Boat Safety Act of 1971 or the recall laws of any other foreign jurisdiction.

ENVIRONMENTAL POLICIES

In keeping with environmental policies and practices, Boston Whaler reserves the right to utilize reconditioned, refurbished, repaired or remanufactured products or parts in the warranty repair or replacement process. Such products and parts will be comparable in function and performance to an original product or part and warranted for the remainder of the original warranty period.

ACCESS FOR SERVICE

The owner must provide Boston Whaler with a reasonable opportunity to repair, and reasonable access to the Boston Whaler Boat for warranty service. Warranty claims shall be made by delivering the Boston Whaler Boat for inspection to a Boston Whaler dealer authorized to service the product. If the owner cannot deliver the product to such a dealer, written notice must be given to Boston Whaler. Boston Whaler will then arrange for the inspection and any covered repair and the owner shall pay for all related transportation charges and/or travel time.

STATUTE OF LIMITATIONS

Without prejudice to your mandatory statutory rights, any action for rescission or revocation against Boston Whaler shall be barred unless it is commenced within one (1) year from the date of accrual of such cause of action, unless a longer period is prescribed by local law. This section shall not apply to Boston Whaler Boats purchased in Australia.

ASSIGNMENT OF COMPONENT WARRANTIES

Except as expressly set out herein, all warranties provided by the manufacturers and distributors of components, equipment, and parts on the Boat (collectively "Component Manufacturers") are hereby assigned to the owner to the extent permitted by the Component Manufacturers, as the owner's sole and exclusive remedy with respect to such items.

OWNER'S OBLIGATIONS

To initiate a warranty claim, it is the responsibility of the owner to contact an authorized Boston Whaler dealer immediately after discovery of any defect, describe the nature of the problem, and provide a hull serial number, date of purchase, and name of selling dealer. The authorized dealer will notify Boston Whaler, who is solely responsible for determining and authorizing in writing the remedial action(s) to be performed at either an authorized Boston Whaler dealership chosen by Boston Whaler or at the Boston Whaler factory. The owner should notify Boston Whaler of any Boat being repaired by an authorized Boston Whaler dealer which has been at the dealership for fifteen (15) days, or of any claimed defect which was not corrected after one repair attempt. Our privacy policies are available at www.bostonwhaler.com.

REGISTRATION & WARRANTY TRANSFER POLICY

The limited warranty coverage is activated by the authorized selling dealer registering the sale of a new Boat with Boston Whaler.

The Ten-year, Three-year, and One-year Limited Warranties are transferable to a subsequent owner, except

the One-year Accessory Warranty which is not transferrable, and this Limited Manufacturer Warranty will not transfer to any new owner of a Boat which has been salvaged and resold, or resold after a declaration of a total loss or a constructive total loss, i.e., the cost of repair exceeds the value of the Boat. The new owner must fill out and submit the online Boston Whaler warranty transfer form, accessible from www.bostonwhaler.com. A copy of the bill of sale will be required to submit with the form. The warranty transfer must be completed within 30 days of purchase. Notwithstanding anything in this Limited Manufacturer Warranty to the contrary, Boston Whaler reserves the right to reject any warranty transfer request for a Boston Whaler Boat that has been damaged, neglected, or otherwise previously excluded from warranty.

MODIFICATIONS & SEVERABILITY

The terms and conditions contained herein, as well as those of any documents prepared in conjunction with the sale of this vessel may not be modified, altered or waived by any action, inaction, or representations, whether oral or in writing, except upon the expressed, written authority of a management level employee of Boston Whaler. The invalidity or unenforceability of any one or more of the provisions herein shall not affect the validity and enforceability of the other provisions.

SAFETY

It is your responsibility (as well as the responsibility of any other operator of this Boat) to be familiar with and observe all local, state and federal laws, rules and regulations regarding Boating, navigation and Boating safety. You and any other operator of this Boat should take a course in Boating and Boating safety before operation of this Boat and should be completely familiar with all systems regarding safe operation of this Boat. Personal flotation devices should be worn by each passenger in accordance with applicable standards and state and federal law.

THE FOLLOWING SECTION IS APPLICABLE TO EMEA CONSUMERS ONLY

Boston Whaler Boats come with guarantees that cannot be excluded under EU and/or local Consumer Law. For the avoidance of doubt, the Boston Whaler Limited Manufacturer Warranty does not in any way adversely affect any possible right and/or protection the retail owner may have under said applicable legislation.

THE FOLLOWING SECTION IS APPLICABLE TO AUSTRALIAN CONSUMERS ONLY

Boston Whaler Boats come with guarantees that cannot be excluded under the Australian Consumer Law. Retail owners are entitled to a replacement or refund for a major failure and compensation for any other reasonably foreseeable loss or damage. Retail owners are also entitled to have the goods repaired or replaced if the goods fail to be of acceptable quality and the failure does not amount to a major failure.

This Limited Manufacturer Warranty does not cover any expenses that retail owners may incur claiming the warranty.

The benefits to retail owners given by this Limited Manufacturer Warranty are in addition to other rights and remedies of the consumer under a law in relation to the goods or services to which the Limited Manufacturer Warranty relates.

World Headquarters
100 Whaler Way, Edgewater, FL 32141
011 1 (386) 428-0057
bostonwhaler.com

**CALIFORNIA EVAPORATIVE EMISSIONS
CONTROL SYSTEM WARRANTY STATEMENT**

YOUR WARRANTY RIGHTS AND OBLIGATIONS

The California Air Resources Board and Boston Whaler, Inc. are pleased to explain the evaporative emission control system's warranty on your 2024 MY spark-ignition marine watercraft (SIMW). In California, new spark-ignition marine watercraft must be designed, built, and equipped to meet the State's stringent anti-smog standards. Boston Whaler, Inc. must warrant the evaporative emission control system on your spark ignition marine watercraft for the period listed below provided there has been no abuse, neglect, or improper maintenance of your spark-ignition marine watercraft.

Your evaporative emission control system may include parts such as: carburetors, fuel tanks, fuel lines, fuel caps, valves, canisters, filters, vapor hoses, clamps, connectors, and other associated components.

MANUFACTURER'S WARRANTY COVERAGE:

This evaporative emission control system is warranted for three years. If any evaporative emission-related part on your spark-ignition marine watercraft is defective, the part will be repaired or replaced by Boston Whaler, Inc.

OWNER'S WARRANTY RESPONSIBILITIES:

- As the spark ignition marine watercraft owner, you are responsible for performance of the required maintenance listed in your owner's manual. Boston Whaler, Inc. recommends that you retain all receipts covering maintenance on your SIMW, but Boston Whaler, Inc. cannot deny warranty solely for the lack of receipts.
- As the SIMW owner, you should however be aware that the Boston Whaler, Inc. may deny you warranty coverage if your spark-ignition marine watercraft or a part has failed due to abuse, neglect, or improper maintenance or unapproved modifications.
- You are responsible for presenting your spark-ignition marine watercraft to a Boston Whaler, Inc. distribution center or service center as soon as the problem exists. The warranty repairs should be completed in a reasonable amount of time, not to exceed 30 days. If you have a question regarding your warranty coverage, you should contact Boston Whaler, Inc. at 877-294-5645.

SIMW EVAPORATIVE EMISSIONS WARRANTY PARTS:

Fuel tank	Grade Valves
Fuel feed hoses	Fuel Fill Deck Plate w/Cap and Pressure Relief Valve
Fuel Line Fittings	Hose Clamps on Fuel System Components
Fuel Demand Valves	Fuel Level Vent Valve

All other parts not listed that may affect the evaporative emissions control system.

Privacy Statement

Thank you for purchasing a boat or requesting information from Boston Whaler. This Privacy Statement is to inform you how we collect, use, disclose, and safeguard the personal information you provide to us through your purchases, requests for brochures, product registration cards, promotions, surveys, call centers, or other customer contacts. To see our full Privacy Policy and any updates, please visit www.bostonwhaler.com and select the Privacy Statement link. “Personal information” may include your name, age, mailing address, residential phone number, or e-mail address. It may also include income ranges, marital status, product or lifestyle preferences, and information concerning dealer service.

How we collect personal information: Our authorized dealer provided Boston Whaler or our company in the European Union with personal information collected at the time of your boat order/purchase with other product registration data and will continue to provide warranty and servicing information on your boat. We will send you customer satisfaction surveys which you may elect to return to provide us with information on your boat purchase and your servicing needs. Your personal information may be gathered by or shared with Boston Whaler’s marketing providers and affiliated companies, who have comparable levels of privacy protection, for the purposes described in this statement. Boston Whaler, your dealer, and our marketing providers collect personal information when your request information about our companies and from surveys, promotions, contests, correspondence, your e-mails, telephone inquiries, web forms, and other communications. **How We Use and Disclose Personal Information:** Unless you advise us otherwise, Boston Whaler, our authorized dealers, affiliated companies, and our marketing providers may generally collect, use, disclose, hold, and file your personal information for the following purposes: (1) Providing goods, brochures, information, incentives, and/or services to you or on your behalf; (2) Fulfilling the terms of our limited warranty or other service obligation; (3) Facilitating recalls or service campaigns if necessary; (4) Reviewing goods and/or services provided to you in product, services, and marketing analyses; (5) Ensuring your satisfaction through surveys or other contacts; (6) Administration, billing, accounting, and collections; and protecting against fraud and error; and (7) Investigating a breach or a contravention of a law, complying with a subpoena, warrant, court order, or as required or otherwise permitted by law. Boston whaler will not sell your personal information or subject you to telemarketing or unsolicited e-mail.

Safeguards: We use security safeguards appropriate to the sensitivity of personal information to protect it from loss or theft, as well as prohibiting unauthorized access, disclosure, copying, use or modification of your personal information. These safeguards include restricted access to offices and equipment, security clearances, the use of passwords and/or encryption, publishing our privacy policy to appropriate personnel with instructions to act in accordance with its principles, and contractual provisions with our marketing agents and authorized dealers to follow the principles of our privacy policy.

Access and correction to your personal information: Subject to the exceptions provided by applicable law, we will provide, upon written request, your specific personal information collected in a form which is generally understandable. Your Personal Information is held by us and for us by our marketing agency, Rollick Company, who has contractually agreed to protect your information according to our privacy policies at the following addresses: Boston Whaler Inc., 100 Whaler Way, Edgewater, FL 32141. Please direct corrections, withdrawal of consent for specific purpose, complaints or other inquiries regarding personal information to: Rollick Company, 1078 Headquarters Park Drive, Fenton, MO, 63026; phone: (636) 343-9988, fax: (636) 326-3282. You can withdraw consent for us to use your personal information at any time or provide corrections upon providing to us a 30-day notice, unless withdrawing consent would impede the performance of legal obligations. We are required by law to provide you with information for product recall and other product safety relates purposes. The withdrawal of your consent may also adversely affect our ability to provide products and services to you and to maintain our relationship. Please note, notifying us will not result in withdrawing consent from your dealer, who should be contacted separately.

Obtaining consent: If any supplementary disclosure is required, we will obtain your consent for disclosure to other persons or organizations and for other purposes than stated herein, unless otherwise permitted by law.

Thank you for your business. We hope you have many years of wonderful boating experiences!

Introduction

Owner's Packet

The owner's packet is a large, zippered bag that contains all the manuals and instructional information for non-Boston Whaler equipment and systems on your boat. Read and retain this information.

Owner's Manual

The contents of this manual:

• Provides basic boating safety information	• Details the boat's features and equipment
• Outlines the fundamentals of boat use	• Contains maintenance information

You must learn to operate this boat as well as read, understand and use this manual. This manual does not give you a course in boating safety or how to navigate, anchor or dock your boat. Operating a power boat safely requires more skills, knowledge, and awareness than is necessary for a motor vehicle.

Your Responsibilities

For the safety of you and your passengers, other boaters as well as people in the water, you must:

• Take a boating safety course	• Understand and follow the <i>rules of the road</i>
• Get instruction in proper boat handling	• Learn how to navigate

Contact Us

Boston Whaler, Inc.

877-294-5645

www.bostonwhaler.com

Warranties

In addition to the Boston Whaler® Limited Warranty, each component and/or system on your boat has its own warranty that can be found with the specific information and manual for that component. These are included with your owner's information packet. Please locate, read, and retain the individual warranties.

Boating Information*

A comprehensive background in boating can be found in the book, *Chapman Piloting: Seamanship & Small Boat Handling*, by Elbert Maloney. For boating courses in North America, contact one of the following organizations:

THIS PAGE INTENTIONALLY LEFT BLANK

Safety Labels

The most important aspect of boating is safety. Although every effort is made to address the numerous issues regarding the safe use of this vessel, it is strongly recommended that you avail yourself of the training and knowledge available through boating-safety courses.

Mounted at key locations throughout this vessel are safety labels which advise the operator of imperative safety precautions to follow when operating and/or servicing equipment. Label categories are broken down by color and type.

DANGER

Denotes an immediate hazard exists that **WILL** result in severe personal injury or death.

WARNING

Denotes hazards or unsafe practices that **MAY** result in severe personal injury or death.

CAUTION

Denotes hazards or unsafe practices that **COULD** result in minor personal injury, product or property damage.

NOTICE

Denotes information that is important to know prior to operation and/or maintenance, but is not hazard related.

Below are black and white examples of safety labels which appear throughout this manual and must be observed when operating or servicing your boat. Learn to recognize the label category and understand the explanations before reading this manual.

DANGER

Denotes an immediate hazard exists that **WILL** result in severe personal injury or death.

WARNING

Denotes hazards or unsafe practices that **MAY** result in severe personal injury or death.

CAUTION

Denotes hazards or unsafe practices that **COULD** result in minor personal injury, product or property damage.

NOTICE

Denotes information that is important to know prior to operation and/or maintenance, but is not hazard related.

ATTENTION

Denotes information found in the owner's manual to call attention to the safe operation or certain features of this vessel.

Safe Boating Means

- Knowing the limitations of this vessel
- Following navigation rules (rules of the road)
- Be aware of people and objects in the water
- Not boating in water or weather conditions that are beyond the boat's and operator's capability
- Never operating the boat while under the influence of drugs or alcohol
- Being aware of passenger safety at all times
- Reducing speed when there is limited visibility, rough water, boats or structures

NOTICE

As a boat owner or operator, you are responsible for the safety of you, your passengers, and other boaters.

Boating in beautiful weather and calm water conditions can be a wonderful experience. But boating requires considerably greater skills than operating a land vehicle. Taking a boating course is the best way to prepare for a safe and enjoyable experience on the water. For additional information:

- Take a USCG, U.S. Power Squadron or equivalent boating safety course.
- Call the BoatUS Foundation at 800-336-2628 for information on available courses or go to boat.us.org
- Get hands-on training on how to operate your boat properly.

Safe Boating Checklist

Before Departure

- Check weather forecast
- Check required documents are on board
- Check navigation charts are on board
- Check safety equipment is on board
- Ensure passengers and crew have received safety instructions on procedures, location, and use of safety equipment.
- Check drain plugs are installed
- Check bilge pumps are working and clean
- Check blower is working
- Check navigation lights are working
- Check horn is working
- Check fuel system has no leaks or fumes
- Check fuel filter is tight and clean
- Check power steering fluid is full (if applicable)
- Check steering system is working smoothly
- Battery connections and fluid levels (if applicable)
- File float plan with friend or relative

Trailing (if applicable)

- Check boat position is secure on trailer
- Check tiedowns are tight
- Check winch is locked
- Check trailer hitch is connected
- Check engine clearance in trailering position
- Check safety chains are attached
- Test lights, brake lights, and turn signals
- Adjust mirrors for trailering

After Return

- Dry and stow PFDs and other safety gear
- Fill fuel tanks (allow for expansion) to prevent condensation
- Check fuel system for leaks
- Check bilge pump is operating properly
- Check bilge is clean and leak free
- Check in with float plan notification person

General Considerations

- Know how this vessel handles under different conditions. Recognize your limitations and the boat's limitations. Modify speed in keeping with weather, sea, and traffic conditions.
- Instruct passengers on location and use of safety equipment and procedures.
- Instruct passengers on the fundamentals of operating this vessel in case you are unable to do so.
- You are responsible for passenger's actions. If they place themselves or the boat in danger, immediately correct them.
- Remember the *Rule of Thirds*: Use one third of the fuel for the trip outbound, one third for the return trip, and keep one third for reserve.

Maintaining Control

High-performance boats require intimate knowledge of each vessel's handling characteristics for safe, high-speed operation.

- Learn the effects of trim, steering and throttle changes at gradually increasing levels of speed.
- Approach full throttle while adjusting trim for safe handling of the vessel.

On the water there are no marked traffic lanes, no traffic signs or lights, and boats have no turn signals. The boat operator must keep her or his attention focused not only on what's ahead but what's on the left, right, and behind the boat.

The operator must always be alert to approaching boats (from the rear, right and left sides, as well as those ahead). There can be a variety of navigational hazards in the water including partially submerged debris, rocks, sand bars or dangerous currents, to name a few.

Your passengers are relying on you to operate and maneuver the boat safely so that they are not in danger of going overboard. If you turn too quickly or increase or decrease speed abruptly, your passengers are at risk of being thrown overboard or thrown about the boat.

When visibility becomes impaired because of weather or time of day, use navigational lights to ensure other boats can see you. In addition, if high bow angle causes reduced visibility, slow down to allow sufficient time to react if an emergency occurs.

Boarding

- Board only one person at a time.
- Never jump into boat; step or climb.
- Load gear after aboard. Carrying gear while boarding can cause you to lose balance.
- Distribute weight evenly.
- Instruct passengers where to sit during on-plane operation to reduce the possibility of falling overboard during high speed maneuvers.
- If gear is not immediately needed, stow it in secure areas.
- Safety gear must be immediately accessible at all times.

Impaired Operation

WARNING

Control Hazard - Federal laws prohibit operating a boat while under the influence of alcohol or drugs. These laws are vigorously enforced.

The detrimental effects of alcohol and drugs are increased by wind, waves and sun, and will decrease your response time and ability to react in critical situations. Give special attention to the effects of alcohol and drugs while boating. No other single factor causes as many marine accidents and deaths. Death or serious injury and damage to personal and private property can result from being impaired while operating a boat.

Operator Responsibility

Your enjoyment on the water depends on you, your equipment and other people who, like yourself, boat responsibly. As a boat operator you should:

- Make sure that all occupants always wear a U.S. Coast Guard-approved life jacket while on the water.
- All boat operators should complete a boating safety course (a requirement in many states).
- All boat operators must become familiar with the proper operation of all vessel features prior to departure.
- Always maintain a safe speed.
- Be aware of conditions in every direction always when underway.
- Mind your wake. It can capsize a small boat or damage moored boats or other property. You are responsible for damage caused by your wake.
- Reduce speed and post a lookout to identify hazards when:
 - Visibility is impaired
 - In rough water
 - In congested waterways
- Display navigation lights between sunset and sunrise and during periods of restricted visibility, such as rain, fog, haze, etc.

WARNING

A qualified operator must be in control of the boat at all times. Do not operate the boat while under the influence of alcohol or drugs. Never operate this vessel at speeds which exceed the operator's ability to react if an emergency develops. At night, turn on the appropriate navigation lights and cruise at a reduced speed that allows you plenty of time to avoid dangerous situations.

WARNING

STABILITY HAZARD

- **Load boat properly. The manufacturer's load rating is the maximum weight allowed under normal conditions. Adjust downward if weather, water or other conditions are adverse.**
- **Allow passengers to ride only in areas that do not pose a hazard to themselves or the boat.**
- **Do not allow passengers to ride on the bow of a closed-bow boat.**
- **Do not allow several passengers to ride in the bow of a small open-bow boat, causing the boat to plow in the water.**
- **Do not allow passengers to ride on the stern cushion or gunwales.**
- **Do not overload the stern.**
- **Observe manufacturer's recommended on-plane seating locations.**
- **Passengers should remain seated while boat is moving.**

Personal injury hazard - Stay alert. Use of drugs, alcohol, or other substances which impair judgement poses a serious threat to yourself and others. The boat operator is responsible for the behavior of passengers.

Drowning hazard - Boats must carry one wearable personal flotation devices (PFDs) for every passenger on board. Boats must have at least one throwable life preserver.

Slip hazard - Wet decks are slippery. Wear proper footwear and use extreme caution on wet surfaces.

Legally Mandated Equipment

Consult your national boating law enforcement agency. The following equipment is the minimum required by the United States Coast Guard (USCG) for a boat over 26 ft. (7.9 m) in length but less than 39.4 ft. (12 m) in length.

Personal Flotation Devices (PFD's)

One USCG approved Type I, II or III is mandatory for each person aboard.

One throwable Type IV device is also required to be onboard and located so that it is immediately available.

A Type V device is acceptable (see *PFD Classifications*, later in this chapter) if worn for approved use. Always wear a PFD when boating.

WARNING

There is rarely time to reach stowed life jackets in time of emergency. Boaters should always wear a properly fitting, approved life jacket when on the water.

Children and non-swimmers must wear PFDs at all times when aboard.

NOTICE

Depending on the state or country of operation, the operator of a vessel may be fined for failure to comply with local or national rules regarding PFD usage.

Fire Extinguishers

If there is no fixed fire extinguishing system installed, two size 5-B or one 20-B portable fire extinguisher(s) must be on board. If a fixed system is installed one 5-B portable fire extinguisher is required. The American Boat & Yacht Council (ABYC) recommends three 5-B type ABC portable fire extinguishers be on board and located within easy reach of helm, outside of engine compartment, and galley or passenger area.

Fire Extinguisher Locations

There should be three on this vessel. One located near or at the transom. One located near or at the helm. One located easily accessible inside the cabin.

Sound-producing Devices

Ensure a sound-producing device such as a horn or whistle is on board. Navigation rules require that a sound made by an audible device be capable of a four second blast, and be audible for 1/2 mile (.80 km).

Visual Distress Signals

If you operate this vessel in coastal waters or on the Great Lakes, you must have visual distress signals for day and night use on board. At least three day/night combination pyrotechnic devices must be carried, readily accessible, in serviceable condition, and not be expired. Non-pyrotechnic substitutes include one orange flag for day-use and one electric S-O-S signal light for night-use. Store all pyrotechnic signals in a well marked, waterproof container.

Additional Required Equipment

Your vessel comes equipped with other mandated equipment such as an oil discharge and trash placard, navigation lights, certified marine sanitation device (option), and ventilation for your generator (option).

Additional Safety Equipment

In addition to the legally-mandated equipment, the following items are necessary for safe boating, especially if your boat will be out of sight of land.

- First aid kit
- Charts/Maps
- GPS or LORAN
- Marine VHF radio
- Moisture repellent
- Mooring lines
- Fenders
- Waterproof flashlights
- High power spotlight
- Spare propeller
- Anchor
- Compass
- Manual bilge pump
- Spare keys
- EPIRB emergency positioning indicating radio beacon
- Boat hook
- Extra batteries
- Instruction manuals
- Lubricating oil
- Tool kit:
 - Screwdrivers (Phillips and flat)
 - Pliers (regular, Vise-grip, tongue and groove)
 - Wrenches (box, open end, Allen and adjustable)
 - Socket set (metric and U.S.)
 - Electrical tape and duct tape
 - Hammer
 - Spare parts kit (spark plugs, fuses, etc.)

Carbon Monoxide (CO)

⚠ DANGER

- **Fumes from the engine(s), generator(s) and other equipment and appliances that burn fuel contain carbon monoxide. Carbon monoxide can kill you. Open all doors, hatches, curtains, and windows to allow fresh air to circulate and dissipate carbon monoxide present in enclosed spaces, especially when the boat is moored or anchored.**
- **Proper ventilation must be maintained, even during inclement weather to prevent dangerous levels of carbon monoxide build-up.**
- **Sleeping aboard a boat requires a working carbon monoxide detection system, preferably in each sleeping quarter.**

Carbon monoxide (CO) is an odorless, colorless, and extremely toxic gas produced by engines, heaters, stoves or generators. When inhaled it combines with hemoglobin in the blood, preventing absorption of oxygen and is unlikely to be noticed until the person is overcome.

Prolonged exposure to low concentrations or very short exposure to high concentrations can result in asphyxiation and death.

Symptoms of carbon monoxide poisoning include:

- Dizziness
- Ringing in the ears
- Unconsciousness
- Headaches
- Nausea

If symptoms are detected, get medical attention as soon as possible. Symptoms of CO poisoning are often confused with seasickness or intoxication, so those affected may not receive the medical attention they need.

The poisoning victim's skin often turns cherry red. If CO poisoning is suspected, have the victim breathe fresh air deeply. If breathing stops, resuscitate. A victim often revives, then relapses because organs are damaged by lack of oxygen.

Carbon monoxide (CO) can accumulate in dangerous

concentrations anywhere in or around your boat including on back decks, swim platforms, or in water around generator exhaust. CO can remain in or around the boat at dangerous levels even if your engine is no longer running. Remember:

- If you smell exhaust you are inhaling CO.
- Changing course and speed can improve ventilation.
- Adjusting the canvas enclosure and/or vents and other opening devices can improve ventilation.

To minimize the danger of carbon monoxide accumulation when the engine is running (or by use of fuel burning equipment):

- Do not idle the engine without moving the boat for more than 15 minutes at a time.
- Inspect the exhaust system regularly.
- Operate all fuel burning appliances, such as charcoal, propane, LPG, CNG or alcohol cooking devices in areas where fresh air can circulate.

Carbon Monoxide Detector

⚠ DANGER

Never ignore an alarm.

Carbon monoxide detectors are located in the salon, mid-berth, and the stateroom (see Figure 1.7.1). These units will sound an alarm when dangerous levels of CO are detected. The detector is very sensitive and notifies occupants before dangerous amounts of carbon monoxide can accumulate which allows you to take measures to dissipate CO from the affected areas (see Figure 1.7.2). Read and understand the warnings and recommendations in this chapter to help keep occupants safe from carbon monoxide.

Testing

At least once a week depress the *Test/Mute* button until the green LED turns on and release to determine if the detector is working properly. The alarm triggers two alarm cycles (two sets of four beeps, 5 second silence between). The red LED will flash once every 5 seconds.

Carbon Monoxide Detector

Figure 1.7.1

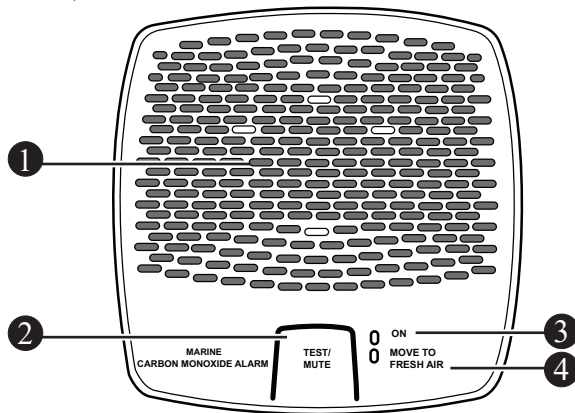

- | | |
|--------------------|--------------------|
| 1 ALARM HORN | 5 POWER INDICATOR |
| 2 TEST/MUTE BUTTON | 6 DANGER INDICATOR |

Maintenance:

Avoid spraying liquids directly on an alarm.

End of Life Signal

The carbon monoxide (CO) detector(s) is equipped with an end of life signal indicating the unit has reached the end of its service life and must be replaced. Refer to the unit's operation manual for further instructions. The end of life signal can be deactivated so that it does not go off. Deactivating the alarm is permanent and reactivation is not possible. Do not deactivate unless you have a replacement alarm available to install.

In the event the CO alarm activates:

- Evacuate enclosed areas immediately.
- Shut off fuel burning equipment or appliances
- Open hatches, doors, port lights, etc. to improve ventilation.
- If making way, head boat into the wind.

⚠ DANGER

Even in rainy cold weather, ventilation must be maintained to avoid carbon monoxide poisoning. You will get wet and/or cold.

Carbon Monoxide Accumulation Scenarios

Figure 1.7.2

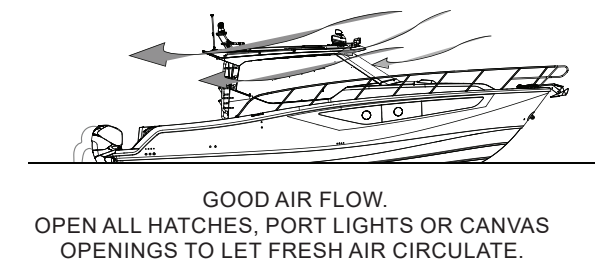
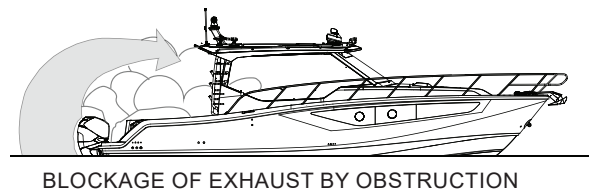
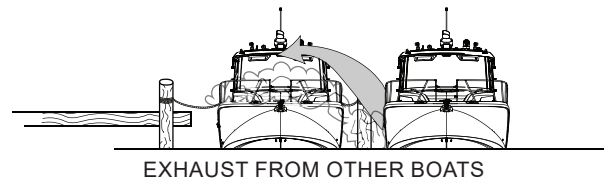

Lifesaving Equipment

Even strong swimmers can tire quickly in the water and drown due to exhaustion, hypothermia, or both. The buoyancy provided by a personal flotation device (PFD) will allow the person who has fallen overboard to remain afloat with far less effort and body heat loss, extending survival time necessary to find and retrieve them.

PFD Requirement

One USCG approved PFD, Type I, II or III for each person aboard or being towed on water skis, tubes, etc.

The law requires that PFDs must be readily accessible, if not worn. Readily accessible means removed from storage bags and unbuckled.

NOTICE

Children and non-swimmers MUST wear PFDs at all times when aboard.

PFD Classifications

Listed below are the several different types of PFDs, each life jacket has different purposes, choose one that will suit your purpose.

Type I, The off-shore life jacket is considered the most buoyant, it is designed to turn an unconscious person face up. Use in all types of waters where rescue may be slow, particularly in cold or rough water conditions.

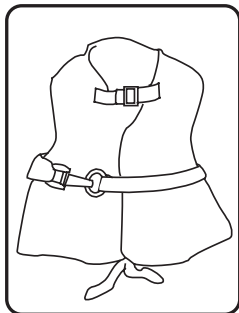

Type II, Near-shore life vest, a keyhole vest with flotation filled head and neck support is also designed to turn a person face up, but the turning action is not as pronounced. Use in calm inland waters or where quick rescue is likely.

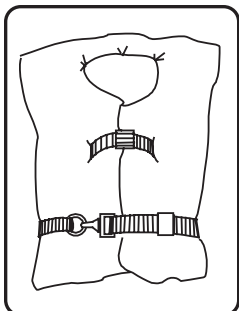

Type III, Flotation-aid Life vest is designed so that conscious wearers can turn face-up. Designed for comfort while engaged in water skiing or other forms of water activities.

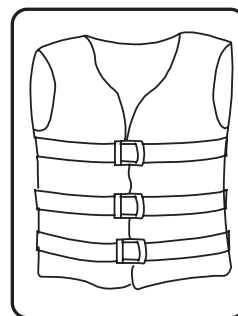

Type IV, Throwable Devices, horseshoe buoys, ring buoys and buoyant cushions are designed to be grasped, not worn.

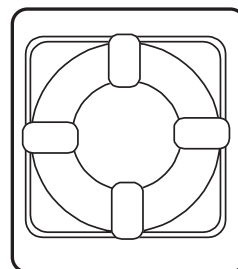

Type V, Special-Use devices, sailboat harnesses, white water vests, float coats, and hybrid vests which have minimum inherent buoyancy and an inflatable chamber.

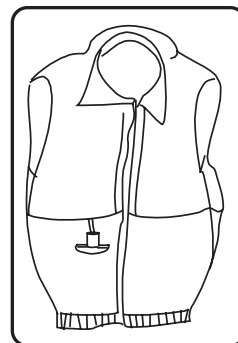

Before purchasing PFDs, ensure that there is an attached tag indicating they are approved by the USCG or by your national boating law enforcement agency. The operator is responsible for instructing everyone onboard on their location and use. The best precaution is to wear the PFD at all times.

Emergency Situations

NOTICE

The law requires the owner/operator to assist any person or boat in distress as long as rendering assistance does not endanger the owner/operator, the passengers or the boat.

Prevention is the safest approach. We hope that you are never involved in an emergency situation, but if you are it is imperative that you react.

Medical Emergency

You may be far from professional medical help when you are boating. At least two persons on board your boat should be CPR certified and have taken a first aid course. Have a well stocked first aid kit on board. Your radio will often be your only link to reaching medical assistance. Keep the radio in working order and understand which channels are used for emergencies. Cell phones can help in some areas, but they are limited and unreliable and should not be used in the place of a good VHF radio.

Water Rescue

In most situations, if someone has fallen overboard they will succumb to hypothermia if not rescued immediately. Life expectancy decreases as rescue time increases in water temperatures below 70°F (21.1°C). There are three steps that must be taken when a person has fallen overboard:

1. Returning to the Victim

- Immediately inform everyone that someone is overboard; keep the victim in sight.
- Slow boat and keep pointing toward the person overboard. At night or in low light, point the best available light source at the person.
- Throw life ring/preserver to the victim, even if they are wearing one as it serves as a marker.

2. Making Contact

- Stop or slow the boat and circle toward the person overboard.
- Try to approach, heading into the wind or into the waves.
- When almost alongside, stop the engine in gear to prevent propeller windmilling.

3. Getting Back Aboard

- Try to reach person overboard with a pole, or by throwing a life preserver. Never swim to them except as a last resort.
- Assist person in boarding. Boarding should be done at stern of boat.
- If person is injured or incapable of boarding by themselves, rescuer should don life preserver with a safety line and enter water to assist.
- Handle person carefully, as potential spinal

injuries could be worsened by rough handling.

- Check for other injuries, render medical assistance immediately.

Unassisted Reboarding

The reboarding ladder can be deployed to assist a person reboarding the boat without assistance. For further information see *Reboarding Ladder* section in chapter 3, *Systems Overview and Operation*.

Fire

DANGER

Fires can spread quickly. Your reaction to the fire is important. Have the proper fire fighting equipment close at hand, and in good working order to respond quickly.

Small fire extinguishers have small discharge times. Aim at the base of the fire with a sweeping motion to maximize the use of the fire extinguisher contents.

Fire is a serious boating hazard. Boats will burn quickly. Do not remain onboard and fight a fire for more than a few minutes. If the fire is out of control and cannot be put out with the fire suppression equipment onboard, abandon ship immediately. The fumes released during a fire are toxic and should be avoided. Even after the fire has been extinguished, proper ventilation of the area is required to minimize exposure to harmful fumes.

To lessen the danger of fire:

- Extinguish all smoking materials, shut off blowers, stoves, engine(s) and generator(s).
- Keep bilge area clean, oil and fuel spills should be cleaned immediately.
- If possible throw burning materials overboard.
- If fire is accessible, release the contents of the fire extinguisher(s) into the base of the fire.
- If the fire is in an enclosed compartment and you have an automatic fire extinguisher that has discharged in the compartment, wait 15 minutes before opening the compartment. Have extinguisher handy in case of a flare up.

- If possible, signal for help. Radio, visual, and audible signal should be used as needed. Also understand, that you must render assistance to any boater requesting help.
- If fire is out of control, grab all necessary survival gear, distress signals, put on personal flotation devices (PFDs) and prepare to abandon ship.
- If you do abandon ship, ensure the passengers have PFDs. Take a head count before entering the water and take another head count when in the water. Stay together.

Smoke Detector

Smoke detectors (also known as smoke alarms) are self-contained safety devices located in several locations in this vessel with the purpose of detecting smoke that may be associated with a fire and sounding an alarm to alert occupants (see Figure 1.10.1). These battery-powered units sense smoke as an indicator of fire. Smoke detectors are located on in the stateroom and the galley and will sound an alarm when dangerous levels of smoke are detected.

REFER TO OWNER'S PACKET FOR COMPLETE INSTRUCTIONS AND WARRANTY INFORMATION.

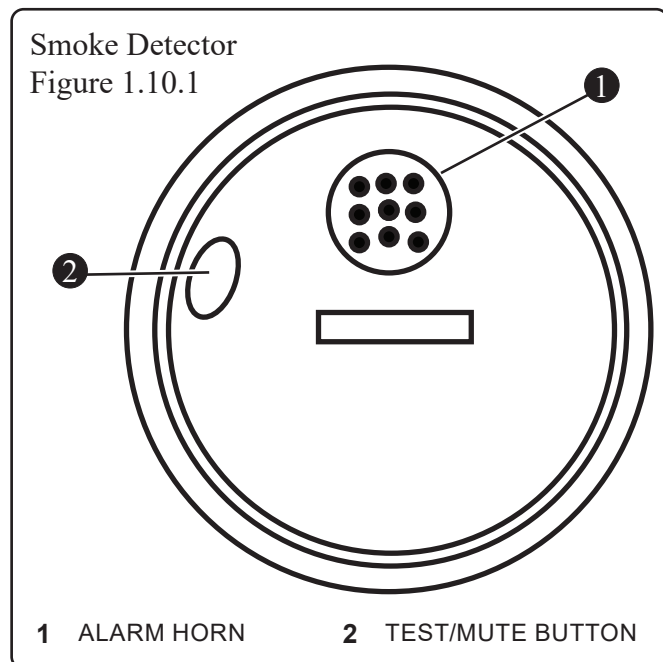

Flooding, Swamping and Capsizing

In the event of flooding, swamping or capsizing:

Flooding

- Always wear your PFD or have it within reach.
- If the bilge pump(s) have not automatically turned on, switch them on immediately.
- Find the source of the flooding and determine the best fix.
- Keep the bilge pumps running until the flooding is under control.
- Call for assistance if the source of the flooding cannot be controlled.
- Head back to port if possible.

Swamping

- Always wear your PFD or have it within reach.
- Swamping is usually a result of wave action, immediately get control of the helm and turn the boat into the waves.
- Swamping can also be caused by an overloaded boat.
- If the bilge pump(s) have not automatically turned on, switch them on immediately.
- The deck scuppers on this vessel are designed to drain the deck of water.
- Keep the bilge pumps running until the flooding is under control.
- Take a head count of all passengers.

Capsizing

- Capsized is when a boat is on its side or completely upside-down (usually as a result of wave action, improper loading or load shifting).
- If the boat will not right itself, get out of the water and climb onto the exposed hull.
- Do a head count for all passengers
- Stay together.
- Usually a capsizing will happen quickly and without warning.
- Use whatever is at hand to signal for help.

The chances of flooding, swamping or capsizing can be reduced by being aware of:

- Weather
- Water conditions
- Proper boat handling techniques
- Proper loading of the boat

Collision

In the event of collision:

- Cut the engine(s)
- Check on passengers
- If the bilge pump(s) have not automatically turned on, switch them on immediately.
- Determine amount of damage to boat structure.
- Call for assistance
- In the event of collision you are required to file an accident report. Contact a state enforcement agency or the nearest USCG office. If you are boating outside U.S. waters, consult the nation you are visiting for accident reporting requirements.

Propulsion, Control or Steering Failure

If there is a propulsion, control or steering failure:

- Stop the engine, (shut off at ignition or pull on the emergency engine shut-off switch.)
- Drop anchor outside of the channel, if possible, to prevent drifting.
- Determine if the problem can be fixed or will assistance be needed.
- Call for assistance if needed.

When loss of propulsion or steering is noticed, your quick reaction is required to prevent further damage to your boat or injuries to your passengers.

Outboard engines require propulsion to control the direction the boat will take. Without propulsion, the steering is virtually useless. If you are in a congested waterway you will need to react quickly to warn others that you have lost power, propulsion or steering control and that assistance will be needed.

Grounding

Running aground may be avoided by paying attention to marker buoys or indicated by waves as they form into breakers when passing over a sand bar. If you do run aground, the course of action depends on how hard the boat hits bottom and whether the boat remains stranded. If it is a simple touch, you may need only to inspect the lower engine drive and the hull of the boat. If possible do a thorough inspection before trying to get loose, throwing the boat into reverse before this is done may do more damage.

Distress Signals

Visual Distress Signals, (VDS)

- USCG regulations require boats in coastal waters and the Great Lakes to carry a visual distress signal (VDS) for day and night use, as well as appropriate for the time of operation. Exempt from the day signals requirement, but not night signals, are boats less than 16 ft (4.8 m), open sailboats less than 26 ft (7.9 m) boats participating in organized events and manually propelled boats.
- If you are required to have visual distress signals, at least three safety approved pyrotechnic devices in serviceable condition must be readily accessible. They must be marked with a date showing the service life which must not be expired.
- Carry three signals for day use and three for night use. Some pyrotechnic devices such as red flares, meet both day and night use requirements.
- Store pyrotechnic signals in a cool, dry location. An orange or red watertight container prominently marked *distress signals* is recommended.

Other recognized visual distress signals include:

- Flames in a bucket
- Code flags November and Charlie
- Black ball and square on orange background.
- Orange flag (certified)

- Electric distress light (certified) for night use
- Dye marker (any color)
- Person waving arms (slowly)
- U.S. ensign flown upside down

Audible Distress Signals, (ADS)

USCG regulations require one hand, mouth or power operated whistle or horn, audible for at least 1/2 mile.

Other recognized audible distress signals include:

- Radio communications (see *Radio Communications* below)
- Radio-telegraph alarm
- Position indicating radio beacon
- Morse code S-O-S (3 short 3 long 3 short) sounded by any means.
- Fog horn sounded continuously.

Radio Communications

A radio is the boat operator's main method of receiving safety information and summoning aid. VHF-FM radio is the primary means of short range communication. Single sideband radio (SSB) is used for longer range communication.

VHF-FM channel 16 and SSB 2182 kHz are designated for emergency use. Such situations are categorized as:

EMERGENCY

MAYDAY, MAYDAY, MAYDAY - used when life or vessel is in imminent danger.

URGENCY

PAN-PAN, PAN-PAN, PAN-PAN (pronounced PAHN-PAHN)-used when a person or vessel is in some jeopardy less than indicated by a MAYDAY call.

SAFETY

SECURITY, SECURITY, SECURITY (pronounced SAY-CURE-IT-AY) - used for navigational safety or weather warning.

An emergency situation will be hectic and there will

not be time to learn proper radio procedure. Learn what to do before you need to do it. If you hear a distress call, stop all radio transmissions. If you can directly assist, respond on the emergency frequency. If you cannot assist, do not transmit on that frequency. However, continue to monitor until it is obvious that help is being provided.

Weather

DANGER

Do not attempt to boat in severe weather conditions. Death or serious injury can occur. Get to shore before the weather turns bad.

Getting caught in severe weather is hazardous. Bad weather and/or rough sea or water conditions can cause an unsafe situation. Consult local weather services for up-to-date forecasts on weather and sea conditions. Television, radio, and internet can give you access to NOAA weather reports that will help you make a determination on where and when to get underway. Following are some weather related rules:

- Understand the design limitations of this vessel.
- Check the weather forecast and water conditions before leaving and while underway.
- Wear a personal flotation device (PFD)
- If bad weather is approaching, immediately seek a safe harbor.

WARNING

A sudden change in wind direction or speed or an increase in wave height indicates deteriorating weather.

NOTICE

Check the weather forecast and water conditions before leaving and while underway

Weather Warning Pennants

Figure 1.13.1

Small craft

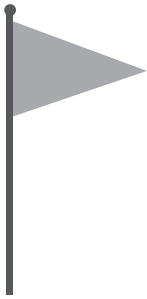

Red flag: Winds to 33 knots (38 mph).

Gale



Two red flags: Winds 34-47 knots (39-54 mph)

Storm

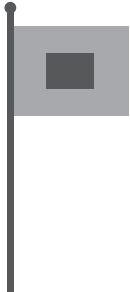

Square red flag with black box: Winds 48-63 knots (55-73 mph)

Hurricane



Two square red flags with black box: Winds above 64 knots (74 mph)

- If bad weather hits, seat passengers in cabin or cockpit deck. Head bow into the wind with enough power to maintain slow headway.
- If you encounter fog, determine your position, set a safe course, slow down and alert other boats of your presence using the appropriate sound signal for your situation at intervals of not more than two minutes apart.
- If lightning storm approaches, dock and disembark. If not possible, have passengers go inside cabin and remain there until storm passes.
- Stay out of the water during a lightning storm. If caught swimming during a storm, get back in boat and remain there until the storm passes. Remember that lightning can strike several miles away from the storm itself. Be aware of the storm location relative to your location and the direction the storm is moving.

Swimming, Diving and Water Skiing

Swimming

- Do not swim near a moving boat.
- Many areas prohibit swimming from a boat except in designated areas.
- Turn off engine in gear (to prevent propeller windmilling) before picking up swimmer.

Diving

Recognize and respect diving flags. Keep at least 30 meters (100 ft) away.

Diver's Flags

Figure 1.13.2

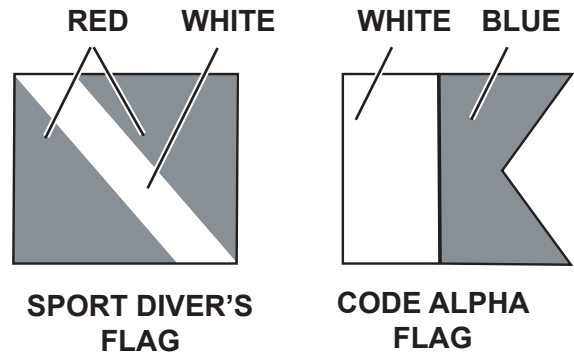

Sport Divers Flag - Red flag with diagonal white stripe marks a diver in the water.

Code Alpha Flag - Blue and white pennant designates boat being used in dive operations.

Water Skiing

- Always have two persons in the boat, one at the controls and one who can easily and continuously look at the skier.
- Insist anyone who water skis knows how to swim.
- Insist that skiers wear approved personal flotation devices (PFD's)
- Ski only in daylight when visibility is good.
- Never drive the boat directly behind a water skier. At 22 knots (25 m.p.h.), it takes only 5 seconds to overtake a fallen skier who was 60 meters (200 feet) in front.
- Ski only in areas where skiing is permitted.
- Observe local restrictions on length of tow line.

- Learn skiing hand signals to ensure proper communication with the boat (see Figure 1.14.1).
- Vessel handles differently while towing a skier. Experiment carefully to learn the difference.
- Skiers may start from the shore or dock, if boat traffic allows. When returning, pick up skiers from water. Do not ski back to shore or dock.
- Give immediate attention to fallen skiers.
- Keep a downed skier in sight and on the operator's side of the boat when approaching the skier. Never back up to anyone in the water.
- Turn off engine before picking up skier.
- If the skier suddenly releases tow rope, it can whip back into cockpit. Spotters be prepared to take appropriate action to avoid injury.

Water Skiing Signals

Figure 1.14.1

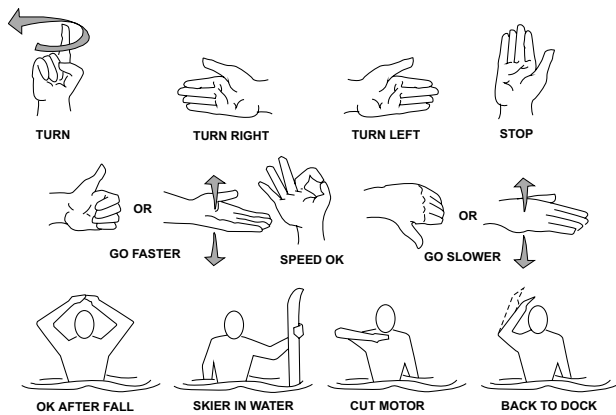

Turn – Arm raised, circle with index finger extended.

Turn Right – Extend arm out from body to the right.

Turn Left – Extend arm out from body to the left.

Stop – Raise arm with palm vertical and facing forward.

Faster – Thumb or palm up, move hand up and down.

Speed OK – Raise arm and make OK symbol with thumb and index finger

Slow Down – Thumb down or palm down, move hand up and down.

OK After a Fall – Clasp hands together overhead.

Skier in Water – Extend one ski vertically out of water.

Cut Motor – Draw finger across throat.

Back to Dock – Pat top of head.

! WARNING

SWIMMING/DIVING HAZARD

- **Keep clear of areas designated only for swimmers and skin divers. Recognize markers used for such areas.**
- **Never swim when there is lightning in the area.**

! WARNING

SKIING HAZARDS

- **Skiers must use a safety approved personal flotation device (PFD).**
- **Ski only during daylight and in good visibility.**
- **Avoid shallow water, other boats, navigational aids and other obstructions.**
- **Keep at least 30 meters (100 ft) from other objects.**
- **Never drive directly behind a water skier.**
- **A competent observer must watch the skier at all times. A competent observer is a person that has the ability to assess when a skier is in trouble, knows or understands water skiing hand signals and is capable of helping a skier.**
- **Keep a downed skier in constant sight.**
- **Turn off engine in gear before you get close to person in the water.**
- **Never back up to anyone in the water.**
- **Use caution in boat when skier is being towed. Sudden release of tow rope can cause it to backlash into the cockpit.**

PERSONAL INJURY HAZARD

Use transom tow ring only to pull water skiers. Unless specified by the manufacturer, any other use, such as parasailing, kite flying, towing other boats, etc. may create too much stress on the tow ring, resulting in personal injury and/or equipment damage.

⚠ DANGER

PROPELLER SAFETY

Before starting the boat, walk to the stern and look in the water to assure there is no one near your propeller. People near propeller may not be visible from helm.

- Never allow passengers to board or exit the boat from the water when engines are on.
- Educate passengers about the dangers of propellers
- Be especially alert when operating in congested areas; never enter swimming zones.
- Take extra precautions near boats that are towing skiers or tubers.
- Never permit passengers to ride on the bow, gunwale, transom, seatbacks, or other locations where they may fall overboard.
- Stop! If someone falls overboard. Slowly turn the boat around, and keep the person in sight as you approach. Turn your engine off first and then bring the person aboard.
- Never reverse this vessel to pick someone up out of the water.

Towed Inflatables

ATTENTION

Ski tow pylons / tower / hardtop / ski eye tow points are not designed for use with tubes. The added stress of the tube may cause a dangerous recoil or damage the equipment. Damage to the pylon / tower / hardtop / ski tow eye is not covered by the boat or equipment manufacturer's warranty if misused. When towing inflatables/tubes, use both stern eye strong points with a tube tow harness to attach the tube tow rope.

Towed inflatable types, aka tubes, produce tremendous stress on the tow point and rope, far greater than devices like waterskis, kneeboards or wakeboards. When pulling a tube use both stern eye strong points in combination with a proper tube harness and tow rope. Parasails and kites should never be used with a recreational boat.

Engine Emergency Stop Switch

⚠ WARNING

Wear lanyard at all times when operating boat. Use it to stop only in an emergency. Do not use it to shut off the engine during normal operation.

The engine emergency stop switch (see Figure 1.15.1) incorporates a shut-off switch, switch clip, lanyard and lanyard clip, which is clipped to the operator when running. If an emergency arises, pull the cord to shut off the engine. This switch also shuts off the engine if the operator leaves the helm accidentally by falling or by being ejected overboard. This likely occurs as a result of poor operating practices.

Engine Emergency Stop Switch

Figure 1.15.1

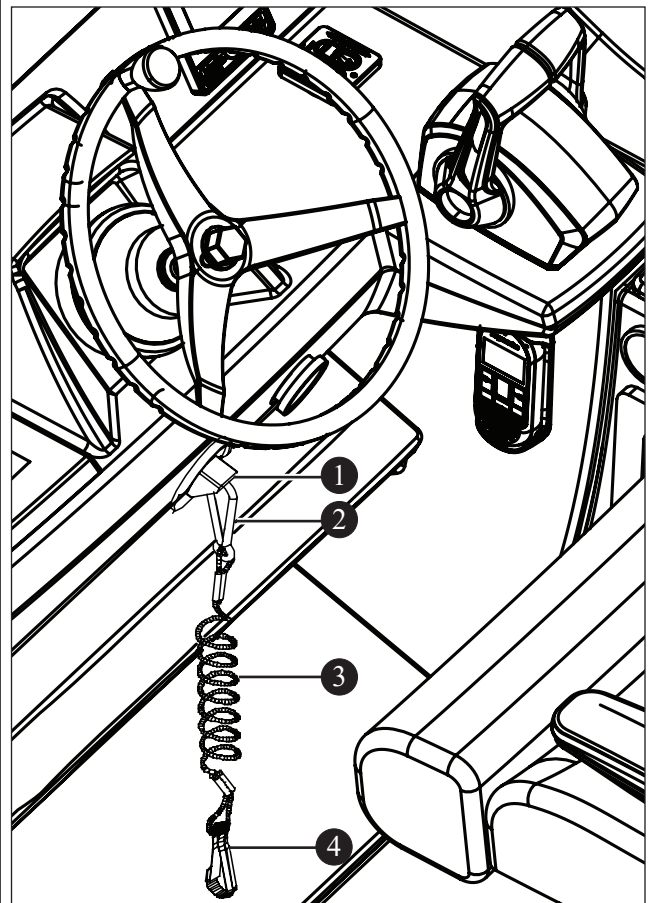

- 1 ENGINE EMERGENCY STOP SWITCH
- 2 HELM SWITCH CLIP
- 3 LANYARD
- 4 OPERATOR SWITCH CLIP

The lanyard should be long enough to prevent accidental activation. Do not let the lanyard become entangled. Accidental loss of power can be hazardous, particularly while docking or in heavy seas, strong current or high winds. Passengers and crew may lose balance and the boat may lose steering control.

Should the operator fall out of the boat at planing speed, it may take several seconds for the engine and propeller to stop turning. The boat may continue to coast for several hundred feet, causing injury to anyone in its path.

1st Mate™ Safety and Security System (Option)

1st Mate is a marine safety and security system that syncs an engine-integrated hub to wearable fobs and the mobile app*, providing alerts to the captain and passengers should anyone go overboard. This system delivers an added level of safety beyond the engine shut-down system that links the captain's lanyard to the engine emergency stop switch. The 1st Mate system offers multiple, customizable security settings including:

- Man overboard alerts should a passenger(s) fall overboard, and engine shutdown should the captain fall overboard.
- Distress messaging and GPS location alerts sent to connected mobile devices.
- Theft-deterrent functionality including wireless engine(s) lock and/or reduced RPMs to prevent unauthorized use

For more information, see the owner's packet or contact an authorized Boston Whaler dealer.

*Download the 1st Mate app at: 1stmate.net

REFER TO OWNER'S PACKET FOR COMPLETE INSTRUCTIONS AND WARRANTY INFORMATION.

Float Plan

Float plans are important to you should you encounter problems on the water. A float plan should contain a description of this vessel along with any distinguishing features. It should describe where you will be boating, your departure time and estimated return. The number and names of passengers, and destination should also be noted.

The float plan should be given to a friend or relative, so they can give the information to a national boating agency like the USCG, in the event you do not return at the time specified on the float plan.

WARNING

Hitting an object in or under the water or boating in dangerous currents can cause serious injury or death to occupants in the boat. You must know where the hazards are and avoid them. In uncharted waters, boat very slowly and post a lookout.

If there are any changes to the float plan they should be conveyed to the person holding the float plan. Once you return you should contact the person holding the float plan to let them know you are back.

Chart Course

To avoid boating in unsafe areas where there are underwater obstructions, shallow water, unnavigable conditions such as dangerous currents, and others, you must chart a course. This means having and using National Oceanic and Atmospheric Administration (NOAA) charts for coastal waters, observing and understanding all navigational aids, using the knowledge and guidance of experienced boaters, and being aware of the tides and times where appropriate. If you are boating in an area you are unfamiliar with, proceed with caution and post a lookout to watch for hazards.

If an object is struck or if you run aground:

- Shut the engine off
- Check the hull for damage
- Check propeller for damage
- If aground, consider bottom grade before moving off, (damage to the hull and propellers could be worsened).
- Determine the tides and whether that change will help or hinder your situation.
- Do not have anyone other than a trained and competent service tow your boat.

Environmental Considerations

Fuel and Oil Spillage

Regulations prohibit discharging fuel or oily waste in navigable waters. Discharge is defined as any action which causes a film, sheen or discoloration on the water surface, or causes a sludge or emulsion beneath the water surface. A common violation is bilge discharge. Use rags or sponges to soak up fuel or oily waste, then dispose of it properly ashore. If there is much fuel or oil in the bilge, contact a knowledgeable marine service to remove it. Never pump contaminated bilge overboard. Help protect your waters.

Excessive Noise

Many areas regulate noise limits. Even if there are no laws, courtesy demands that boats operate quietly.

Wake

**WARNING**

Speed hazard, watch your wake. It might capsize a smaller craft. You are responsible for damage caused by your wake.

**CAUTION**

Reduce speed in congested waterways. Be alert for *no wake* markers.

Power boat wakes can endanger people and vessels. Each power boat operator is responsible for injury or damage caused by the boat's wake. Be especially careful in confined areas such as channels or marinas. Observe *no wake* warnings.

Homeland Security Restrictions

Recreational boaters have a role in keeping our waterways safe and secure. Violators of the restrictions below can expect a quick and severe response.

- Do not approach within 100 yards, and slow to minimum speed within 500 yards of any U.S. Navy vessel.

- Observe and avoid all security zones. Avoid commercial port areas, especially those that involve military, cruise line or petroleum facilities. Observe and avoid other restricted areas near dams, power plants, etc.
- Do not stop or anchor beneath bridges or in channels.

America's Waterway Watch

In March 2005, the United States Coast Guard officially launched *America's Waterway Watch* to encourage the boating public to report suspicious activities in our nation's ports and waterways. *America's Waterway Watch* simply asks anyone who works, lives, or recreates on the water to keep an eye out for suspicious activities. Anyone who spots such activity is asked to call the National Response Center's 24-hour hotline or 877-24WATCH (877-249-2824). If there is immediate danger to life or property call 911 or the USCG on marine channel 16.

Safety Label Locations

Mounted at key locations throughout the boat, safety labels advise the owner/operator of imperative safety precautions to follow when operating and/or servicing equipment. Do not remove or obstruct any label. Replace any label which becomes illegible (see *Label Locations* section next in this chapter).

Label Locations

IMPORTANT: Replace any damaged or illegible labels. Contact your dealer to obtain replacements.

A **⚠ DANGER**

- CONTACT WITH A SPINNING PROPELLER WILL CAUSE SERIOUS INJURY OR DEATH.
- SHUT OFF ENGINES while people are in the water near the boat, on the swim platform, or on the boarding ladder.
- NEVER OPERATE IN REVERSE TOWARD A PERSON in the water.



2417275

B **WARNING**

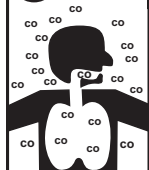

Carbon monoxide (CO) can cause brain damage or death.

Engine and generator exhaust contains odorless, colorless CO gas.

For additional information on CO poisoning, see *Owner's Manual*.

At first sign of CO poisoning, get to fresh air. Signs of CO poisoning include nausea, headache, dizziness, drowsiness, and unconsciousness.

1811368

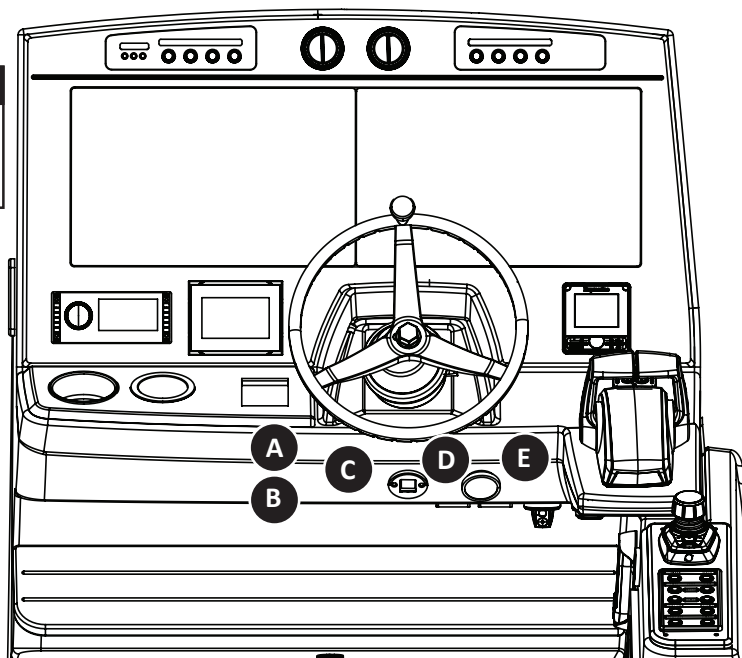

D **⚠ WARNING**

Operating, servicing and maintaining a recreational marine vessel can expose you to chemicals including engine exhaust, carbon monoxide, phthalates, and lead, which are known to the State of California to cause cancer and birth defects or other reproductive harm. To minimize exposure, avoid breathing exhaust, service your vessel in a well-ventilated area and wear gloves or wash your hands frequently when servicing this vessel. For more information go to www.P65warnings.ca.gov/marine.

1795087

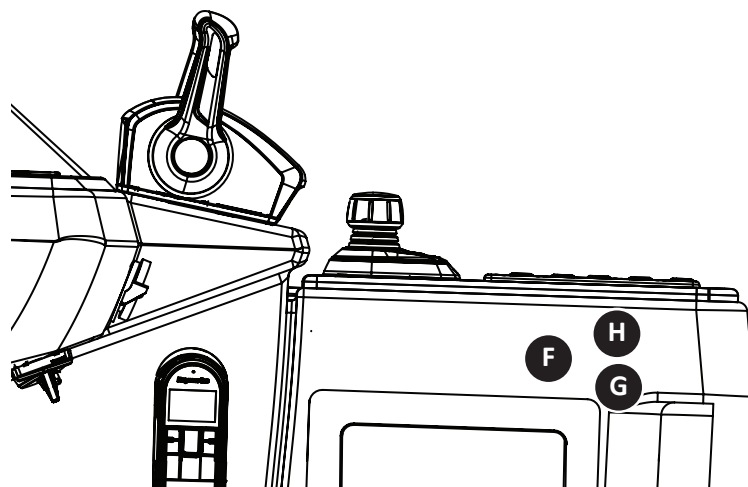

C



LOOK BEFORE YOU PUMP!

USE E10  FUEL

Do not use any fuel containing greater than 10 percent ethanol (E10) in this equipment. It may cause damage or failure and is prohibited by Federal Law. For more information: www.LookBeforeYouPump.com

Ethanol Percentage

<10%  NO 15% - 30% - 85%

2304853

E **ATTACH LANYARD**

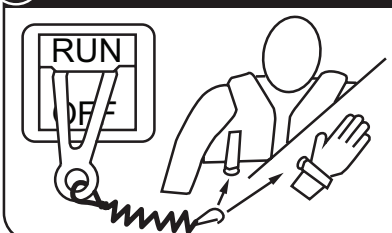

2156485

F Vessel's certification plates (see chapter 2, *General Information*)

THIS BOAT HAS BEEN DESIGNED FOR A MAXIMUM OUTBOARD ENGINE WEIGHT OF

G **4050 lb / 1837kg**

2392887

H **EMISSIONS CONTROL SYSTEM INFORMATION**

MEETS 2024 MY CALIFORNIA EVAP EMISSIONS REGULATIONS FOR SPARK-IGNITION MARINE WATERCRAFT (SIMW)

MANUFACTURER: **BOSTON WHALER**

CALIFORNIA EVAP FAMILY: **RBNWPVSSLNT2**

EMISSION CONTROL SYSTEM: **SM**

2418954

Label Locations

IMPORTANT: Replace any damaged or illegible labels. Contact your dealer to obtain replacements.

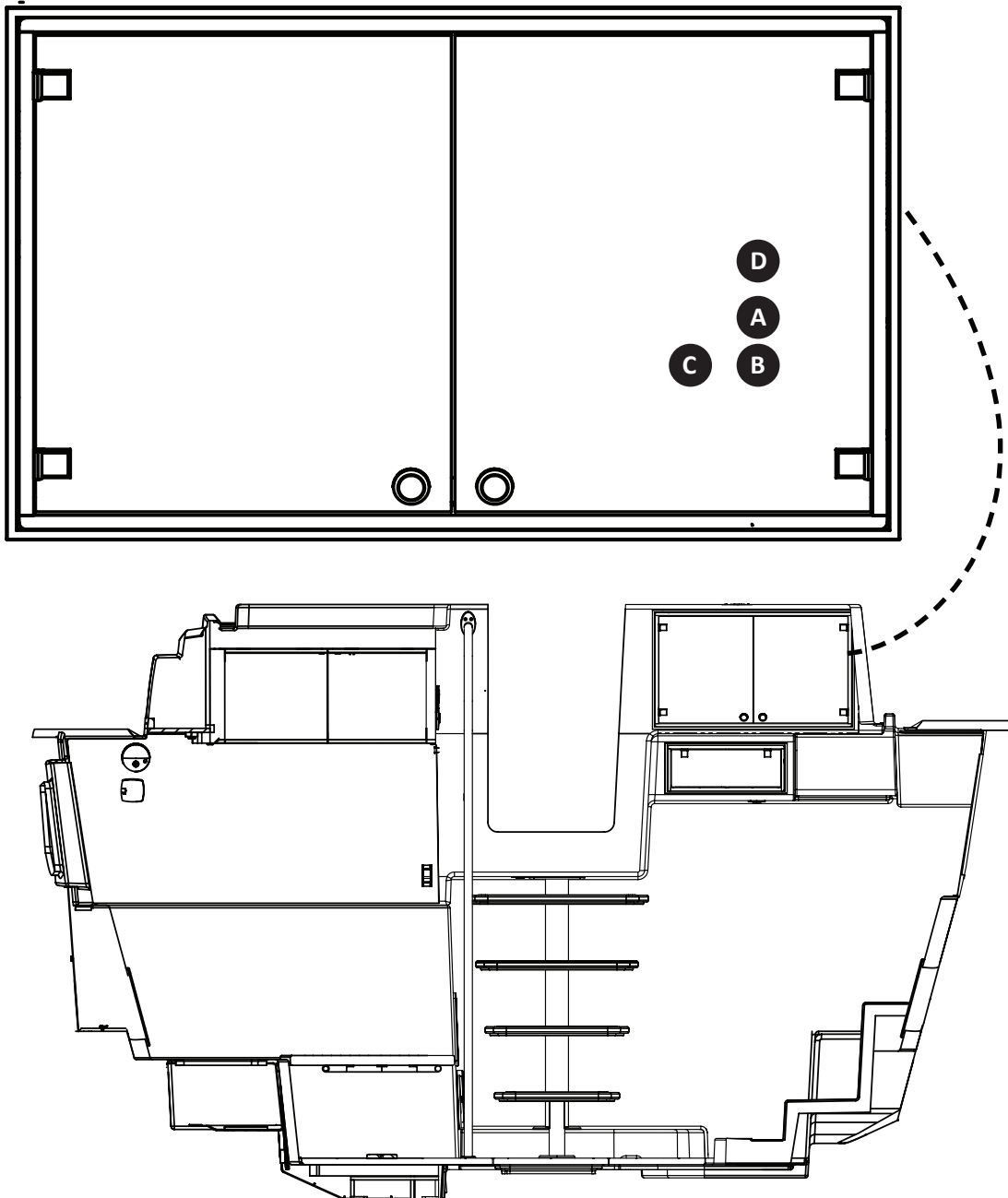

A THIS BOSTON WHALER WAS PRODUCED WITH ITEMS LISTED UNDER THE FOLLOWING PATENTS:
2088481

B COMBINATION BOAT HAWSE PIPE / ACCESSORY TRAY
U.S. PATENT# 7,343,870
2063995

C INTEGRATED BOW THRUSTER
U.S. PATENT# 7,765,946
2063996

D **AVERTISSEMENT**
LES VAPEURS D'ESSENCE PEUVENT S'ENFLAMMER ET ENTRAÎNER DES BLESSURES OU LA MORT.
AVANT LE DÉMARRAGE DES MOTEURS / GÉNÉRATRICES
- VÉRIFIER LA CALE DU COMPARTIMENT MOTEUR POUR ESSENCE OU VAPEURS
- METTRE EN MARCHÉ LE VENTILATEUR PENDANT QUATRE (4) MINUTES
- VÉRIFIER LE FONCTIONNEMENT
FAIRE FONCTIONNER LE VENTILATEUR À UNE VITESSE INFÉRIEURE À LA VITESSE DE CROISIÈRE
2175075 (Canadian vessels)

Label Locations

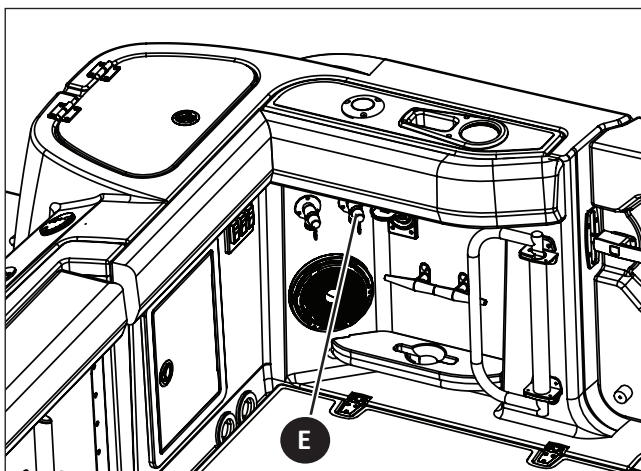
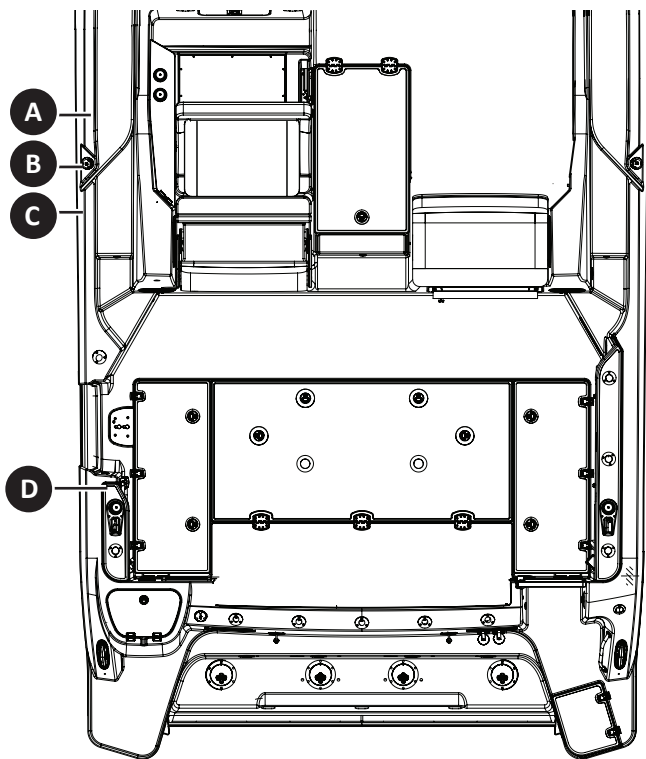

2184707

F BRIDGE CAPACITY INFORMATION
 MAXIMUM WEIGHT CAPACITY UNDERWAY
 (PERSONS AND GEAR) 700 lbs / 318 kgs

2174750

IMPORTANT: Replace any damaged or illegible labels. Contact your dealer to obtain replacements.

A

NOTICE

GASOLINE RECOMMENDATIONS

Minimum octane rating of 91 in the U.S. and Canada.
 Minimum octane rating of 96 outside the U.S. and Canada.
 Refer to engine manual for additional information.

2038447

B

! WARNING



Avoid serious injury or death from fire or explosion resulting from leaking fuel.
 Inspect system for leaks at least once a year.

The use of fuels containing ethanol higher than 10% (E-10) can damage your engine or fuel system and will void the warranty. Never use (E-85).

2096004

For Canadian vessels

C

AVERTISSEMENT

LES FUITES DE CARBURANTS PRÉSENTENT UN DANGER D'INCENDIE OU D'EXPLOSION. INSPECTER RÉGULIÈREMENT LE SYSTÈME. VÉRIFIER LES RÉSERVOIRS DE CARBURANTS POUR DÉCELER DES FUITES OU DE LA CORROSION AU MOINS UNE FOIS L'AN.

MRP# 2175077 LEAKING FUEL

2175077

D

! WARNING

DOOR MUST BE SECURED IN THE CLOSED POSITION WHILE VESSEL IS UNDERWAY.

2063402

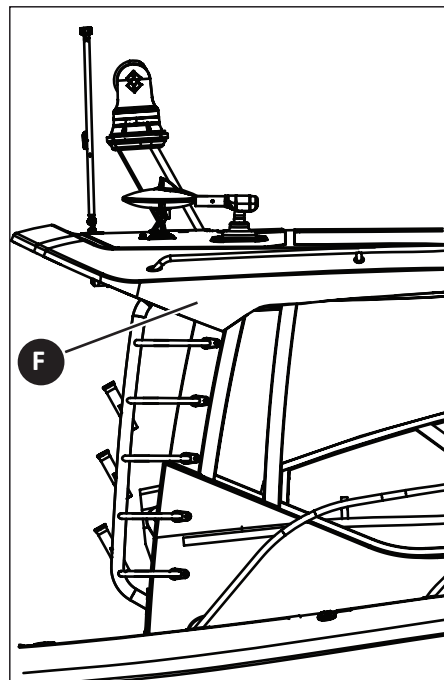

Label Locations

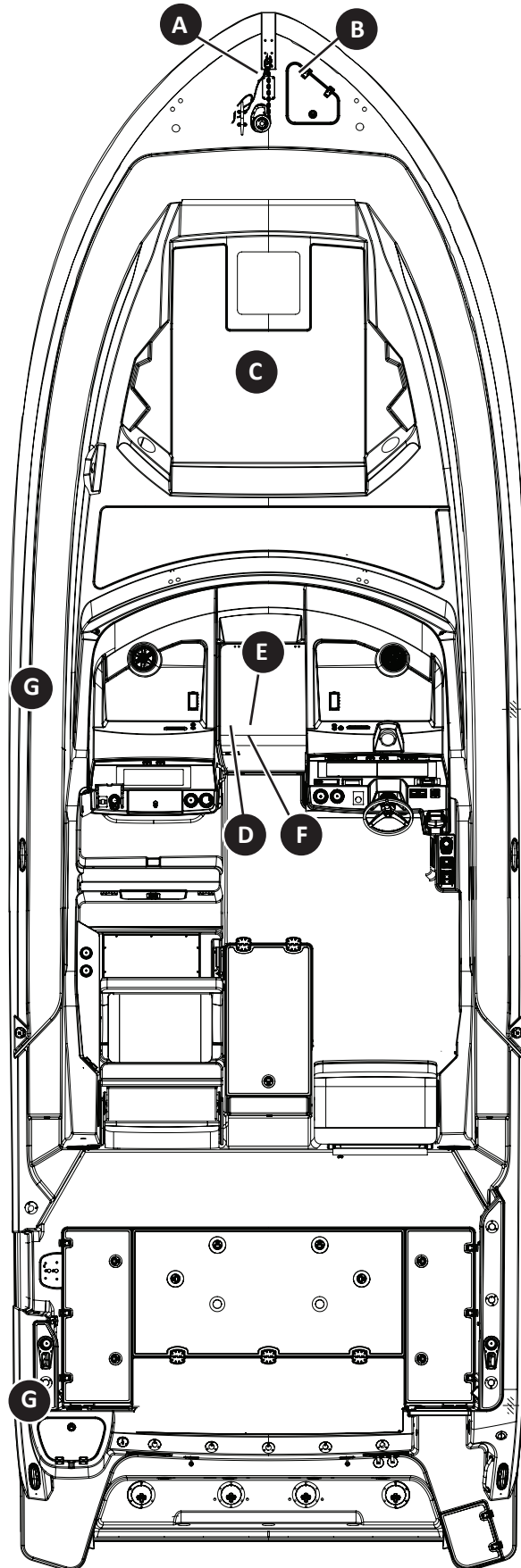

IMPORTANT: Replace any damaged or illegible labels. Contact your dealer to obtain replacements.

A **! DANGER**
STAY CLEAR OF MOVING PARTS.

2028932

B **! CAUTION**
AVOID PROPERTY DAMAGE
 ENGAGE GYPSY LOCK AND ENSURE ANCHOR IS SECURED WITH LANYARD BEFORE GETTING UNDERWAY.

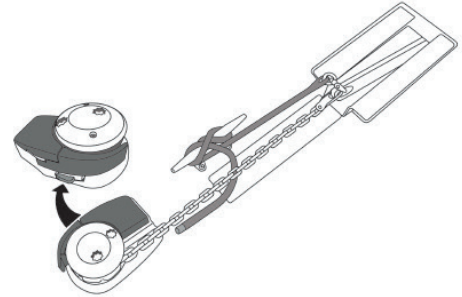

2147835

C **! WARNING**
AVOID SERIOUS OR FATAL INJURY.
DO NOT OCCUPY SEAT WHEN SPEED EXCEEDS 5 MPH

2031217

D **! WARNING**
DOOR MUST BE SECURED IN THE CLOSED POSITION WHILE VESSEL IS UNDERWAY.

2063402

E **! WARNING**
RUNNING BOAT WITH DOOR OPEN COULD INDUCE EXHAUST FUMES INTO CABIN.
SEE OWNERS MANUAL FOR INSTRUCTIONS CONCERNING CARBON MONOXIDE.

2028922

F **! WARNING**

Carbon Monoxide (CO) can cause brain damage or death.

Carbon monoxide can be present in the cabin.

Signs of carbon monoxide poisoning include nausea, headache, dizziness, drowsiness, and lack of consciousness.

Get fresh air if anyone shows signs of carbon monoxide poisoning.

Get fresh air if carbon monoxide detector alarm sounds.

Carbon monoxide detector must be functioning at all times.

1812911 (Label on inside of cabin door)

Label Locations

IMPORTANT: Replace any damaged or illegible labels. Contact your dealer to obtain replacements.

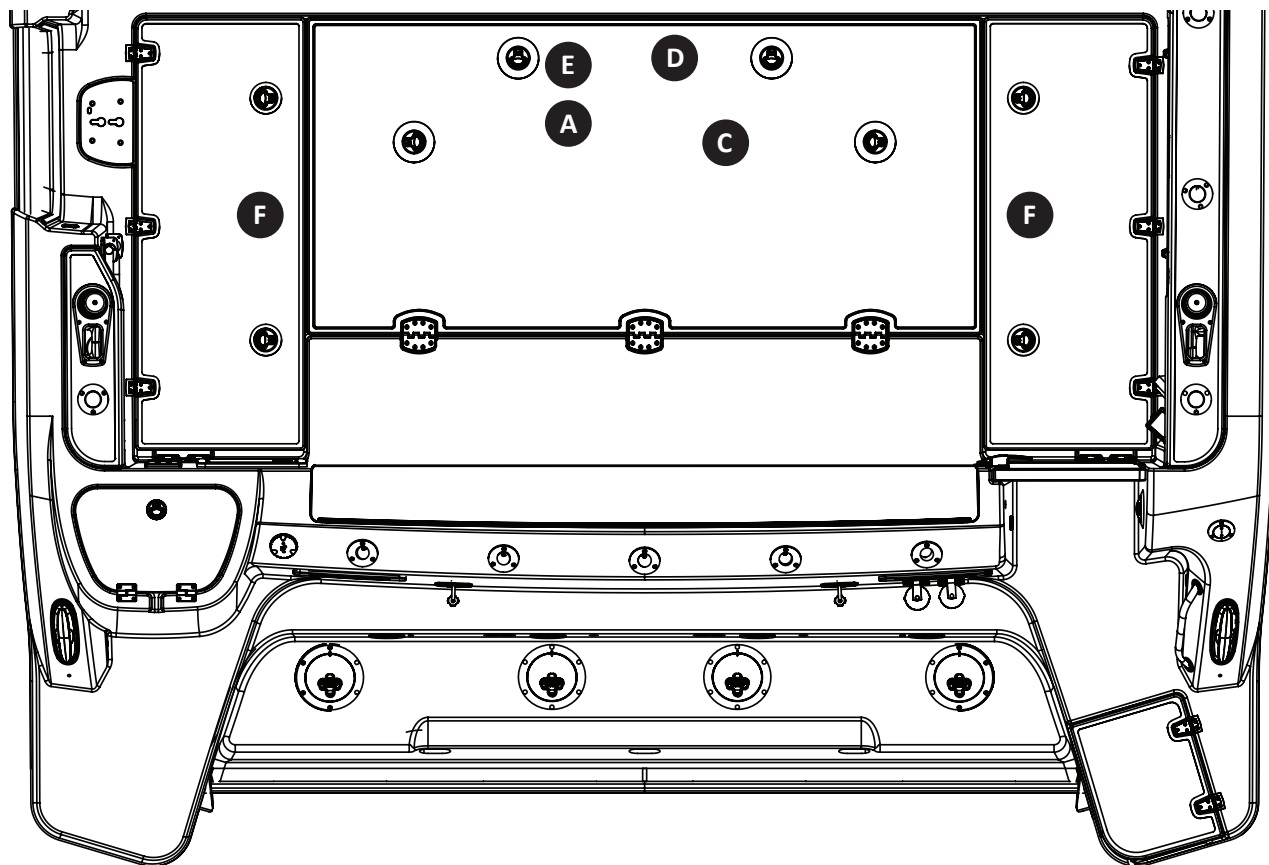

A **NOTICE**
**FIXED FIRE EXTINGUISHER SYSTEM
 MUST BE SUITABLE FOR COMPARTMENT
 VOLUME OF 115 cu. ft.**

2066100

E Vessel's battery plate (see
 chapter 4, *Electrical System*)

C **NOTICE**
 THIS BOAT IS EQUIPPED WITH AN OPTIONAL DIRECT
 OVERBOARD DISCHARGE VALVE. DISCHARGING OF SEWAGE
 DIRECTLY OVERBOARD IS FOR USE WHERE APPROVED ONLY

2063381

F **CAUTION**
AVOID INJURY
BOAT MOVEMENT MAY CAUSE LID TO FALL
KEEP HANDS AND FEET CLEAR OF EDGES WHEN
HATCH IS OPEN

1836858

D **DISCHARGE OF OIL PROHIBITED**
 THE FEDERAL WATER POLLUTION CONTROL ACT PROHIBITS THE
 DISCHARGE OF OIL OR OILY WASTE INTO OR UPON THE NAVIGABLE
 WATERS OF THE UNITED STATES OR THE WATERS OF THE CONTIGUOUS
 ZONE IF SUCH DISCHARGE CAUSES A FILM OR SHEEN UPON OR A
 DISCOLORATION OF THE SURFACE OF THE WATER OR CAUSES A
 SLUDGE OR EMULSION BENEATH THE SURFACE OF THE WATER.
 VIOLATORS ARE SUBJECT TO A PENALTY OF \$5,000.

2063375 or (2063413 CE ONLY)

Label Locations

IMPORTANT: Replace any damaged or illegible labels. Contact your dealer to obtain replacements.

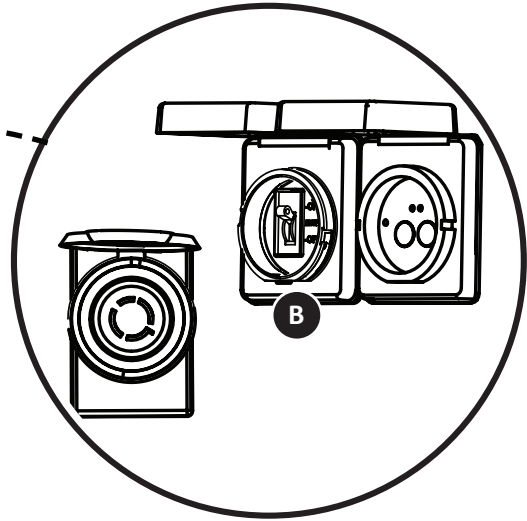
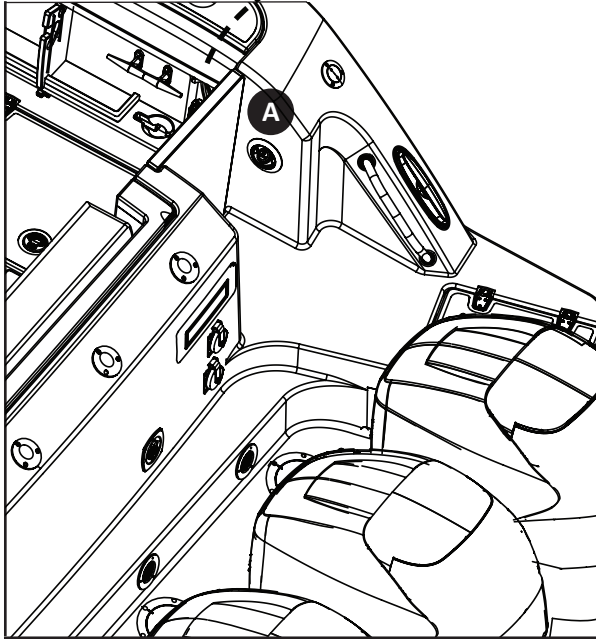

A **⚠ DANGER**
 TRANSOM DOOR MUST BE CLOSED AND SECURE WHEN ENGINE IS RUNNING

2063385

B **⚠ DANGER**
 INTERMEDIATE BREAKER FOR SHORE POWER. UNPLUG SHORE POWER BEFORE REMOVING COVER. WILL CAUSE PERSONAL INJURY OR DEATH

2029122

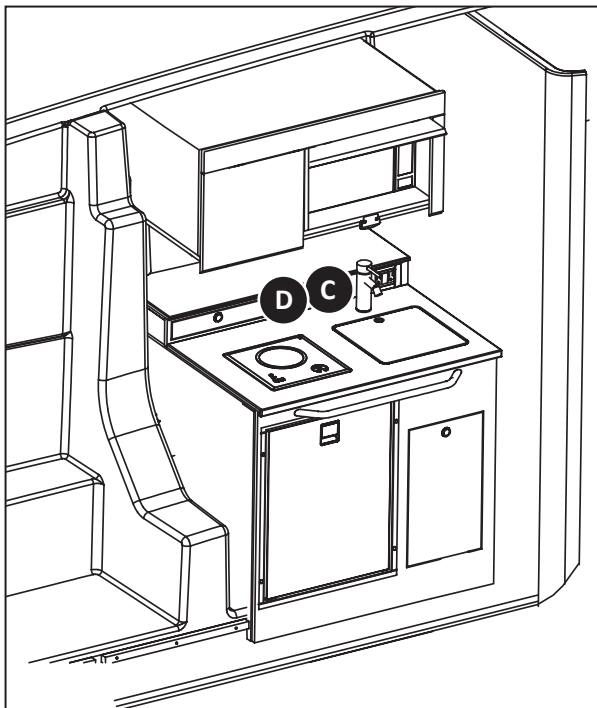

C **Save Our Seas**

It is *illegal* to dump plastic trash anywhere into the ocean or navigable waters of the United States. Violation of these requirements may result in civil penalty up to \$25,000, a fine of \$50,000 and imprisonment for up to five years.

<p>PLASTIC - Includes but is not limited to: plastic bags, styrofoam cups and lids, sixpack holders, stirrers, straws, milk jugs, egg cartons, synthetic fishing nets, ropes, lines, and bio or photo degradable plastics.</p> <p>GARBAGE - Means paper, rags, glass, metal, crockery (generated in living spaces aboard the vessel-what we normally call trash), and all kinds of food, maintenance and cargo-associated waste. "Garbage" does not include fresh fish or fish parts, dish-water, and gray water.</p>	<p>INSIDE 3 MILES (and in U.S. Lakes, Rivers, Bays and Sounds) PLASTICS DUNNAGE, LINING AND PACKING MATERIALS THAT FLOAT ANY GARBAGE EXCEPT DISHWATER/GRAYWATER/FRESH FISH PARTS</p>	<p>DUNNAGE- Material used to block and brace cargo, and is considered a cargo associated waste.</p> <p>DISHWATER- Means the liquid residue from the manual or automatic washing of dishes and cooking utensils which, have been pre-cleaned to the extent that any food particles adhering to them would not normally interfere with the operation of automatic dishwashers.</p>
	<p>3 TO 12 MILES PLASTICS DUNNAGE, LINING AND PACKING MATERIALS THAT FLOAT ANY GARBAGE NOT GROUND TO LESS THAN ONE SQUARE INCH</p>	
	<p>12 TO 25 MILES PLASTICS DUNNAGE, LINING AND PACKING MATERIALS THAT FLOAT</p>	<p>GRAYWATER - Means drainage from a dishwasher, shower, laundry, bath, and washbasin, and does not include drainage from toilets, urinals, hospitals, and cargo spaces.</p>
	<p>12 TO 25 MILES PLASTICS</p>	

2029125

D **NOTICE**
 THIS BOAT IS EQUIPPED WITH AN OPTIONAL DIRECT OVERBOARD DISCHARGE VALVE. DISCHARGING OF SEWAGE DIRECTLY OVERBOARD IS FOR USE WHERE APPROVED ONLY

2063381

Label Locations

IMPORTANT: Replace any damaged or illegible labels. Contact your dealer to obtain replacements.

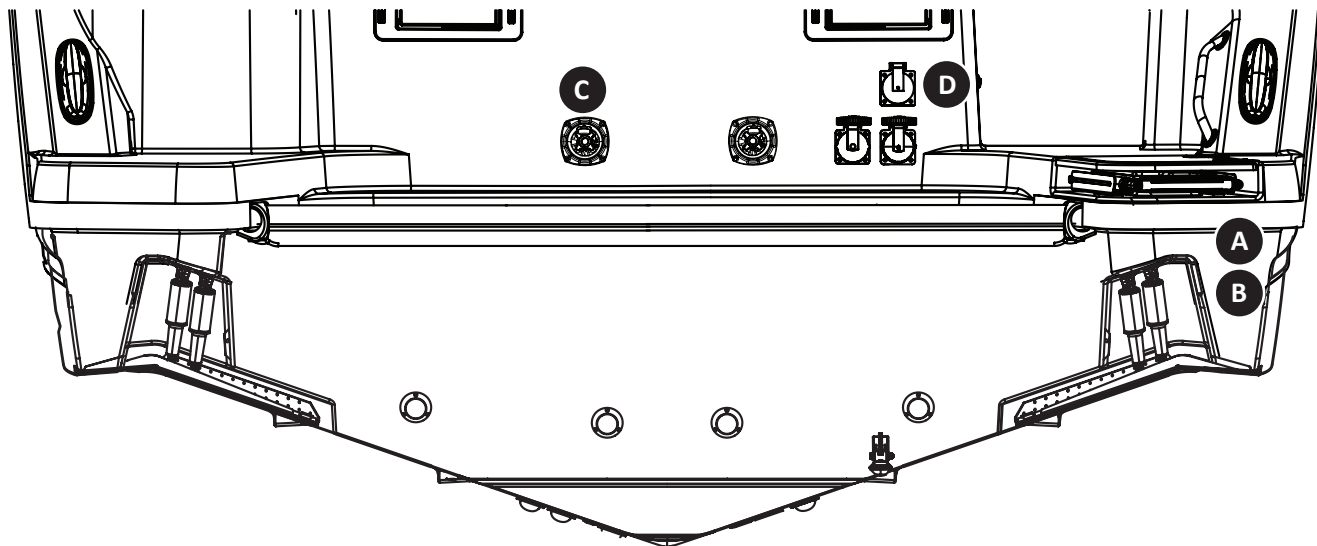

A	⚠ DANGER
	<p>Carbon monoxide (CO) can cause brain damage or death.</p> <p>Engine and generator exhaust contains odorless and colorless CO gas.</p> <p>CO will be around the back of the boat when engines or generators are running.</p> <p>Move to fresh air if you feel nauseous, headache, dizziness or drowsiness.</p>

1811367

B	⚠ DANGER
	<p>CONTACT WITH A SPINNING PROPELLER WILL CAUSE SERIOUS INJURY OR DEATH.</p> <p>STAY CLEAR OF BOAT AND STAY OFF SWIM PLATFORM AND BOARDING LADDER WHILE ENGINE IS RUNNING.</p>

2417276

C	⚠ WARNING
<p>DO NOT LEAVE BOAT UNATTENDED WITH DOCKSIDE WATER HOSE CONNECTED. CONNECT DURING HEAVY WATER USAGE ONLY.</p>	

2028931

D	SHORE POWER WARNING
<p>To minimize shock hazard, connect and disconnect cable as follows:</p> <ol style="list-style-type: none"> 1. Turn off boat's shore power switch 2. Connect cable at boat first 3. If equipped with polarity indicator which activates, disconnect and connect polarity 4. Disconnect at shore outlet first 5. Close inlet cover tightly <p style="text-align: center;">DO NOT ALTER SHORE POWER CABLE CONNECTIONS</p>	

0276808

Label Locations

IMPORTANT: Replace any damaged or illegible labels. Contact your dealer to obtain replacements.



2156485

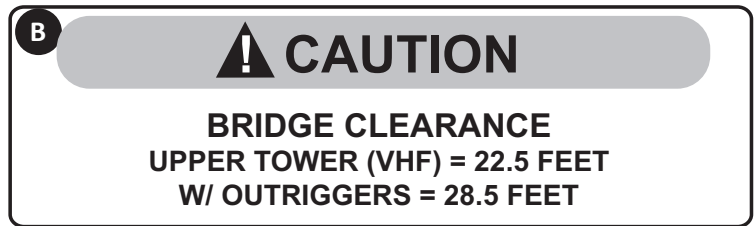

2324441

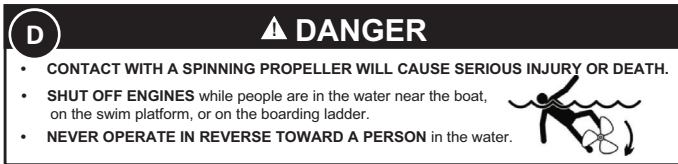

2417275





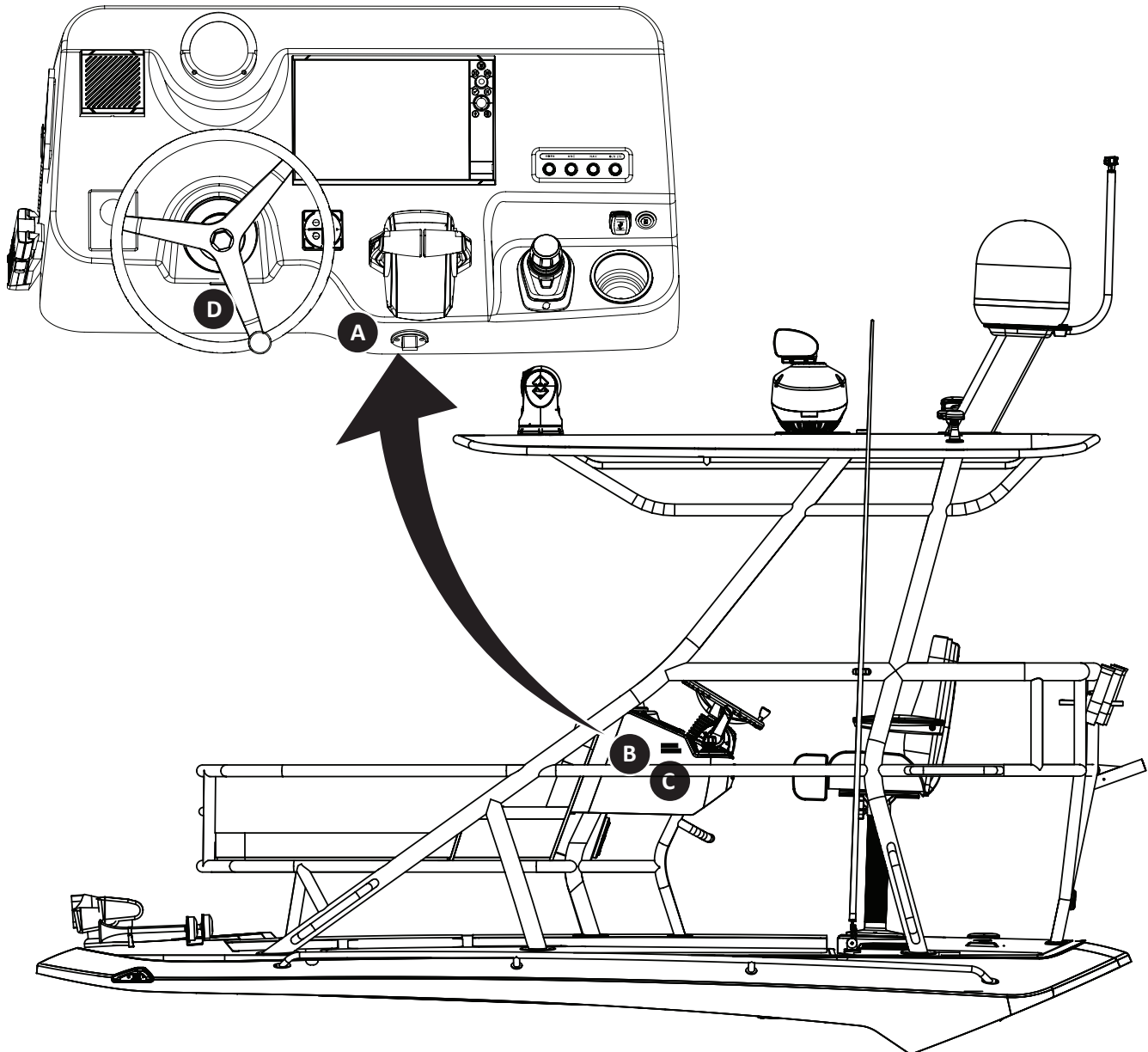





2174750

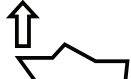

Key to Symbols on Controls

Although not used in this manual, some of these symbols may be found on the controls, gauges, and hardware on this vessel. This page is to help you understand what the symbols mean.

					
ENGINE EXHAUST CONTROL	ENGINE	ENGINE START	ENGINE STOP	WARNING ELECTRICAL HAZARD	FIRE RISK
					
FUEL GENERAL	FUEL LEVEL	LEADED FUEL	UNLEADED FUEL	ENGINE COOLANT WATER JACKET TEMPERATURE	ENGINE OIL PRESSURE
					
BILGE PUMP	OUTBOARD DRIVE	OUTBOARD DRIVE TILT	PROPELLER	SEAWATER	ENGINE ROTATIONAL SPEED
					
BILGE BLOWER	SINGLE LEVER CONTROL	LIFT POINT / SLINGS LOCATION	LIFT POINT	RUNNING LIGHTS UNDER POWER	ROTARY CONTROL (WIDTH OF SYMBOL INDICATES INCREASE)
					
ANCHOR	ANCHOR LIGHT	INTERIOR LIGHT	HORN	WINDSHIELD WIPER AND WASHER	MAGNETIC COMPASS
					
PROPULSION SYSTEM TRIM BOW UP	PROPULSION SYSTEM TRIM BOW DOWN	PROPULSION SYSTEM TRIM	TRIM TAB TRIMMING OPERATION	FRESH WATER	GRAY WATER
					
OIL	BATTERY	CONTROL LEVEL OPERATION DIRECTIONS	WATER PUMP	ACCESSORY	NO OPEN FLAME NO SMOKING

Construction Standards

Boston Whaler® is dedicated to creating a superior product which provides comfort, performance, safety, and reliability. All of our boats comply with United States Coast Guard safety standards and are designed, engineered, and manufactured in accordance with applicable recommendations and guidelines from the American Boat and Yacht Council (ABYC) and certified by the National Marine Manufacturers Association (NMMA).

Hull Construction

Boston Whaler hulls are constructed with our patented unibond-construction process (see Figure 2.1.1). This involves foam injection into a closed-mold system where the foam expands to fill all voids in the hull. When the finished product is pulled from the mold, hull, and deck are chemically bonded to form a solid, inseparable unit.

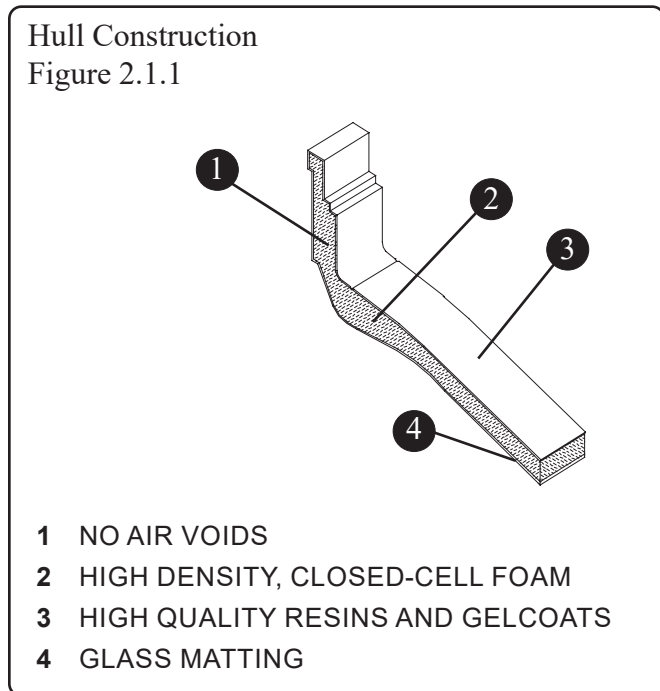

Hull Identification Number

This vessel's hull identification number (HIN) is located on the starboard side of the transom (see Figure 2.1.2). This is the most important identifying factor on this vessel followed by the engine serial numbers.

Be sure to reference these when contacting Boston Whaler about your vessel or engine(s).

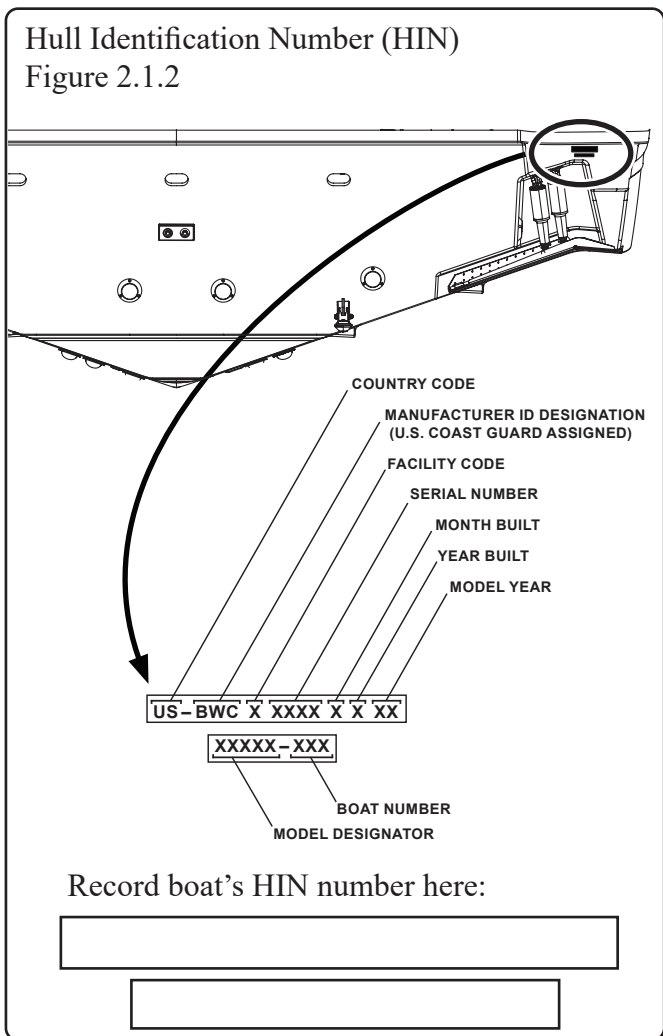

Servicing

When this vessel requires service or maintenance work it should be taken to an authorized Boston Whaler dealer. To find a dealer in your area call 800-942-5379 (domestic/international).

In the unlikely event that a problem is not handled to your satisfaction, discuss any warranty related problems directly with the service manager of the dealership or your sales person. Give the dealership an opportunity to help the service department resolve the matter for you.

Manufacturer's Certification

All boats must comply with federal regulations regarding maximum capacities. The *Specifications and Dimensions* table, listed later in this chapter, indicates the maximum weight, number of persons, and maximum horsepower this vessel is rated to handle. Do not exceed these specifications. The information on the certification plate does not relieve the operator of responsibility. Use common sense and sound judgement when placing equipment and/or passengers in this vessel. Do not load to capacity in poor weather/rough water. The number of seats does not indicate passenger capacity in poor weather/rough water. At speeds above idle, all passengers should be seated on the seats provided.

DANGER

Never carry more weight or passengers than indicated on the certification plate, regardless of weather or water conditions.

Certification Plates

NOTE: The type of capacity plate varies depending on the local governing authority.

NMMA Plate

An NMMA Certification indicates that your boat has been verified by the National Marine Manufacturers Association (NMMA) to be in compliance with applicable federal regulations and American Boat and Yacht Council (ABYC) standards. Recreational vessels up to 20 feet (6.1 meters) have passenger and cargo weight capacities compliant with USCG regulations. Vessels 26 feet (7.9 meters) and under have passenger and cargo weight capacities compliant with ABYC standards. Vessels over 26 feet have NMMA yacht certification.



Canadian Conformity Plate

A Canada Compliance Notice indicates that your boat has been certified to comply with construction standards for small vessels by Transport Canada (TC). Recreational vessels up to 6 meters (19.7 feet) have passenger and cargo weight capacities compliant with TC regulations. Vessels over 6 meters are also compliant with TC regulations, but do not state capacities on the plate.

CANADIAN COMPLIANCE NOTICE
AVIS DE CONFORMITE CAÑADIEN

Boston Whaler (BWC) Edgewater, FL, USA
MODEL / MODLÈ: 405 CONQUEST
DESIGN CATEGORY: B

THE MANUFACTURER DECLARES THAT THIS VESSEL COMPLIES WITH THE PLEASURE CRAFT CONSTRUCTION REQUIREMENTS OF THE SMALL VESSEL REGULATIONS, AS THEY READ ON THE DAY ON WHICH THE CONSTRUCTION OF THE VESSEL WAS STARTED OR ON THE DAY ON WHICH THE VESSEL WAS IMPORTED.
 LE FABRICANT ATTESTE QUE CE BÂTIMENT EST CONFORME AUX EXIGENCES DE CONSTRUCTION DES EMBARCATIONS DE PLAISANCE DU RÉGLEMENT SUR LES PETITS BÂTIMENTS, EN VIGUEUR À LA DATE DU DÉBUT DE SA CONSTRUCTION OU À LA DATE DE SON IMPORTATION.

2324581

Chapter 2 • General Information

CE Mark Builder's Plate

A CE mark indicates that your boat has been certified for the EU and the passenger and cargo weight capacities comply with the International Organization for Standardization (ISO) regulations.

 0609 B	<p style="text-align: center;">BOSTON WHALER, INC. EDGEWATER, FL, USA 405CQT</p> <hr/> <p style="text-align: center;">MAXIMUM</p> <hr/> <p style="text-align: center;">20 + = 1890 kg</p> <hr/> <p style="text-align: center;"> - 1343 kW</p>
---------------------------------	--

2399400

UK Conformity Assessment

A UKCA mark indicates that your boat conforms to current requirements for products being placed on the market in Great Britain (England, Scotland and Wales), and also complies with the passenger and cargo weight capacity regulations set by the International Organization for Standardization (ISO). Currently the mark is used in conjunction with the capacities listed on a CE Builder's Plate.

 0609 B	<p style="text-align: center;">BOSTON WHALER, INC. EDGEWATER, FL, USA 405CQT</p> <hr/> <p style="text-align: center;">MAXIMUM</p> <hr/> <p style="text-align: center;">20 + = 1890 kg</p> <hr/> <p style="text-align: center;"> - 1343 kW</p>
---------------------------------	--

2399400

Australian Builder's Plate

An Australian Builder's Plate indicates that your boat has been certified and the passenger and cargo weight capacities comply with either the International Organization for Standardization (ISO) regulations or American Boat and Yacht Council (ABYC) standards as noted on the capacity plate.

AUSTRALIAN BUILDERS PLATE
 BUILT BY: BOSTON WHALER, INC.
 MODEL: 405 CONQUEST
 INFORMATION DETERMINED: ISO

MAX OUTBOARD: 1343 kW 1837 kg
MAX PERSONS: 20 or not exceeding 1500 kg
MAX LOAD: 3140 kg

⚠ WARNING
 Alteration to the boat's hull or permanent fittings
 may invalidate the particulars on this plate

The maximum persons and maximum load should be reduced in bad weather, or when the boat is operated in adverse conditions.

2393952 or (2393953 With flybridge)

Emission Control System Plate

An Emissions Control System Information plate indicates that your boat is compliant with California emissions regulations.

EMISSIONS CONTROL SYSTEM INFORMATION

MEETS 2024 MY CALIFORNIA EVAP EMISSIONS REGULATIONS FOR
 SPARK-IGNITION MARINE WATERCRAFT (SIMW)
 MANUFACTURER: **BOSTON WHALER**
 CALIFORNIA EVAP FAMILY: **RBNWPVSSLNT2**
 EMISSION CONTROL SYSTEM: **SM**

2418954

Certification Design Category

A recreational craft given design category A is designed for winds that may exceed wind force 8 (Beaufort scale) and significant wave heights of 4 meters and above but excluding abnormal conditions, such as storm, violent storm, hurricane, tornado and extreme sea conditions or rogue waves. A recreational craft given design category B is designed for a wind force up to, and including, 8 and significant wave heights up to, and including 4 meters. A watercraft given design category C is designed a wind force up to, and including 6 and significant wave heights up to, and including, 2 meters. A watercraft given design category D is designed for a wind force up to, and including 4 and significant wave heights up to, and including, 0,3 meters, with occasional waves of 0,5 meters maximum height. The significant wave height is the primary factor for determining design category. Other parameters (e.g. meteorological) are descriptions of when wave heights may occur.

NOTICE

The 405 Conquest is design category B

Power Capacity

The *Specifications and Dimensions* table (see Figure 2.4.1) indicates the maximum rated power listed for this vessel. Do not exceed this rating.

The various engine types offered are powerful and require constant maintenance to stay at optimal performance. The operator must read all information regarding the safety features, warning notices and maintenance schedules for safe operation of the engines.

The engines on this vessel has been tested and proven to be best suited for general use under normal conditions and load.

If re-powering this vessel, pay particular attention to the maximum/minimum horsepower and maximum safe engine weight load this vessel is rated for.

NOTICE

The 405 Conquest is designed for a maximum outboard engine weight of 4050 LBS (1837 kg).

WARNING

Do not exceed maximum engine power rating stated on certification plate. Use caution while accelerating; ensure passengers are safely seated in designated areas and gear is stowed securely.

Specifications and Dimensions Table

Figure 2.5.1

Specifications and Dimensions (measurements are approximate and subject to variance)

A	Overall length (engine up) Overall length V12 (engine up)	45'1" (13.7 m) 46'10" (14.3 m)	P	Bridge clearance (upper station nav light)	20'9" (6.3m)
B	Hull length (bow to swim platform)	41'4" (12.6 m)	Q	Bridge clearance (upper station w/VHF)	22'6" (6.9m)
C	Overall length (engine down) Overall length V12 (engine down)	43'1" (13.1 m) 44'5" (13.5 m)	R	Bridge clearance (upper station w/ outriggers) (not shown)	28'6" (8.7m)
D	Overall height (w/ camera)	17'1" (5.2 m)		Swamped capacity	4050 lbs (1837 kg)
E	Beam	13'6" (4.1 m)		Maximum engine weight	4050 lbs (1837 kg)
F	Draft (engine down) ¹ Draft V12 (engine down) ¹	3'3.5" (1 m) 4'3" (1.3 m)		Max weight (passengers, engines, gear ²)	6922 lbs (3140 kg)
G	Draft (engine up) ¹	2'6" (.76 m)		Maximum persons' capacity	20
H	Freeboard (midship)	4'11" (1.5 m)		Maximum horsepower	1800 HP (1343 kW)
J	Bridge clearance (hardtop light down)	10'5" (3.2 m)		Minimum horsepower	1200 HP (895 kW)
K	Bridge clearance (hardtop light up)	13'5" (4.1 m)		Fuel capacity	620 gal (2347 L)
L	Bow to anchor	1'7" (.5 m)		Fuel capacity (diesel generator)	38 gal (144 L)
M	Bridge clearance (w/ camera)	12'10" (3.9 m)		Water capacity	90 gal (341 L)
N	Bridge clearance (w/ SAT TV)	14'8" (4.5 m)		Waste capacity	30 gal (114 L)
O	Bridge clearance (w/ radar)	11'8" (3.6 m)			

¹ Optional equipment and loading of the boat affects draft measurements. Follow the recommendations listed on the capacity plate regarding the maximum amount of weight this vessel can safely carry.

² Exceeding maximum weight affects boat performance. Do not exceed the weight listed on the capacity plate.

Dimensions and Clearances

Figure 2.4.2

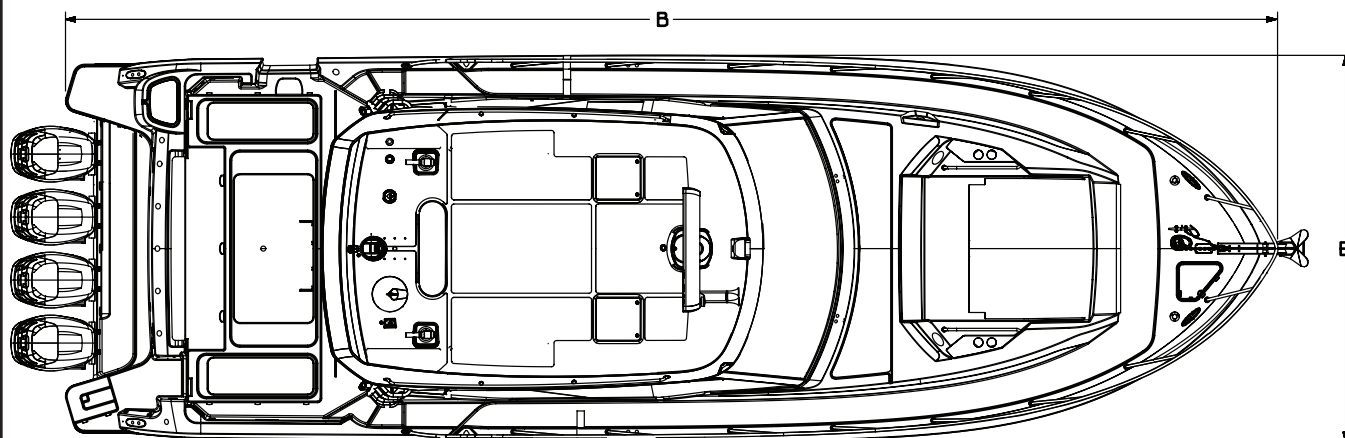

NOTE: Equipment may vary depending on options selected.

Dimensions and Clearances (Continued)

Figure 2.6.1

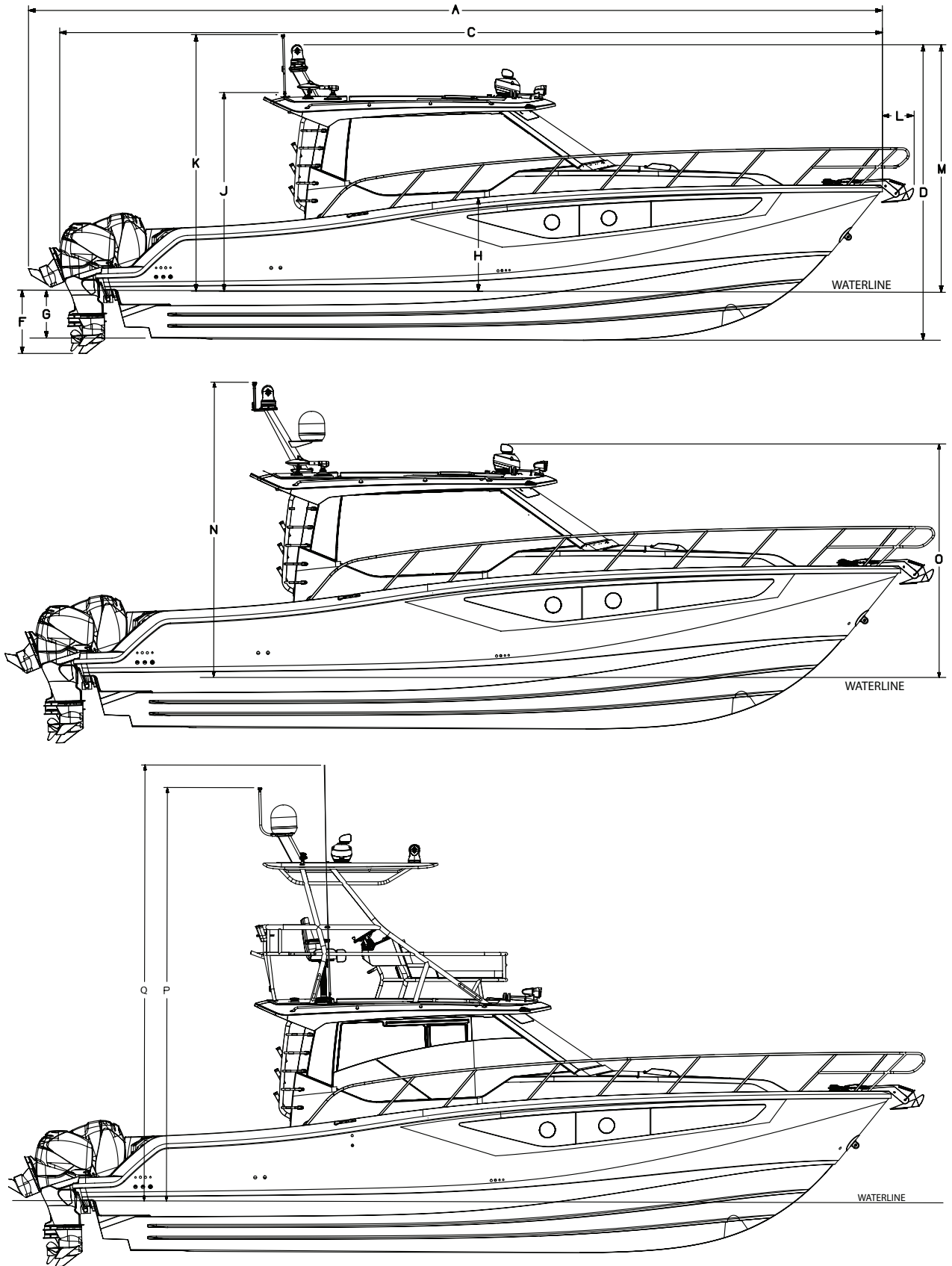

Deck Occupancy

Figure 2.7.1

Working deck

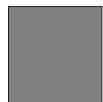

This area is intended for occupation only while mooring, anchoring, loading/unloading or when the boat is at rest.

Accommodation deck



Movement in this area should be done with extreme caution while the boat is underway. A sudden shift in boat direction can cause a loss of balance and lead to injury or death.

Stay off



Do not stand or walk in this area. Serious injury could result. If necessary, stand or walk only where non-skid is applied.

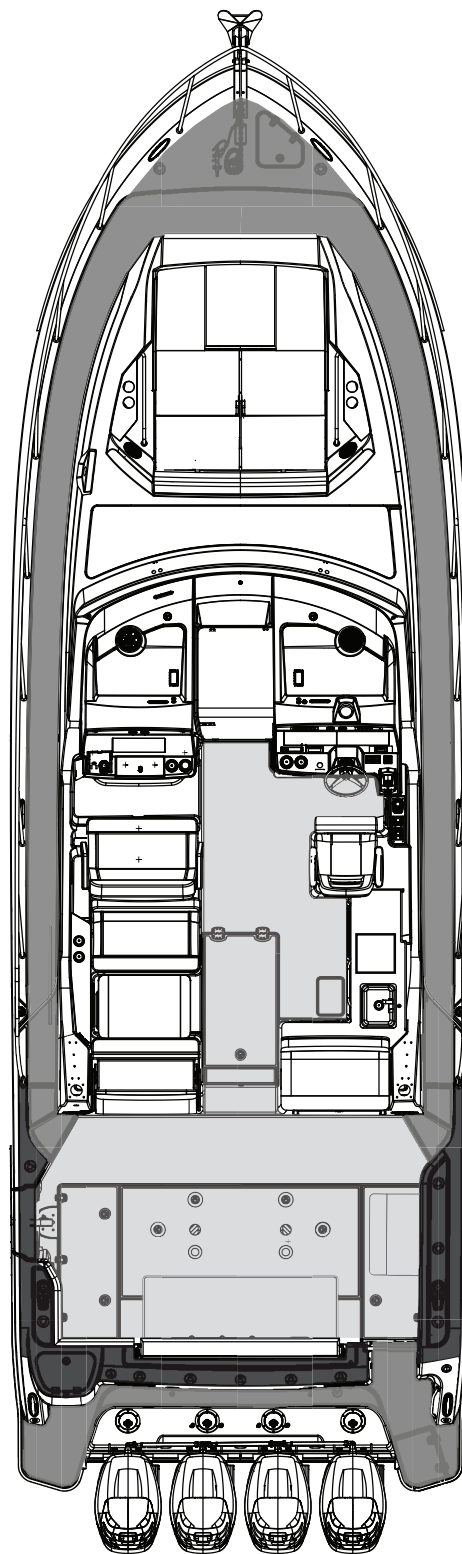

DANGER

Be aware of your footing while the boat is underway, slipping or falling could result in serious injury or death, especially if the boat is in motion or in rough seas. Keep the accommodation deck clean, so if movement is necessary it will be free of obstruction.



WARNING

- Gelcoat surfaces are slippery when wet. Use extreme caution when walking on wet surfaces.
- Never occupy the working decks while the boat is underway.
- Use care when waxing to ensure that walkways are not made slippery.

Recommended Occupant Locations

Seating and On-plane
Figure 2.8.1

! WARNING
Never allow passengers to ride in an area (i.e. bow, gunwales, transom, etc.) that will pose a hazard to themselves or the boat.

-  = Recommended seating locations
-  = Recommended standing locations

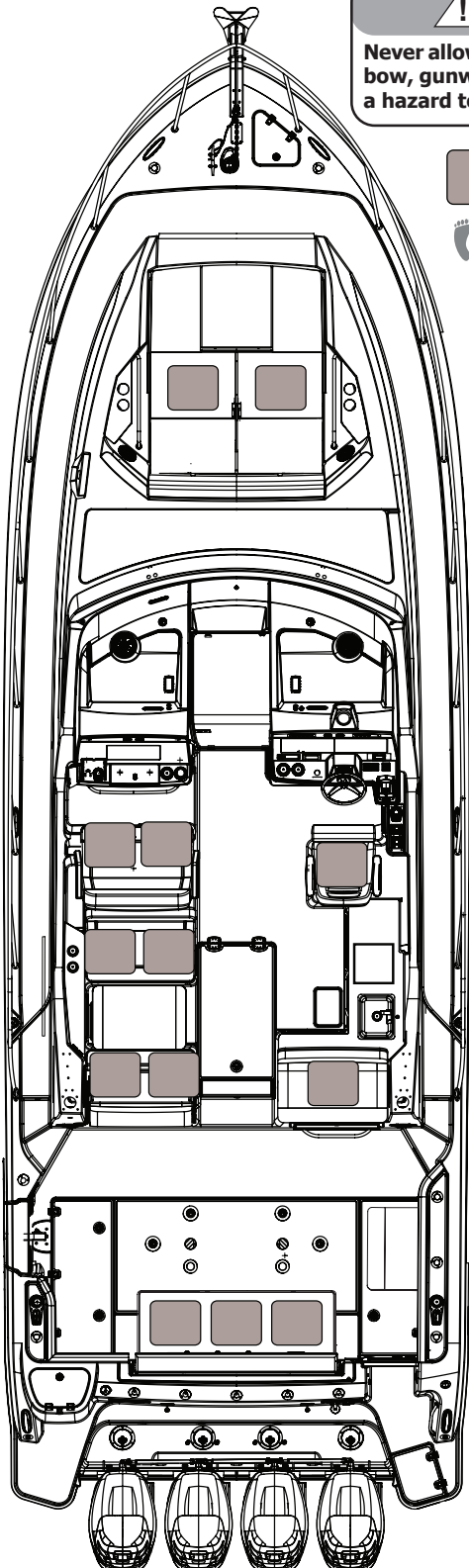

Recommended occupant locations while moored, at idle or under 5 mph

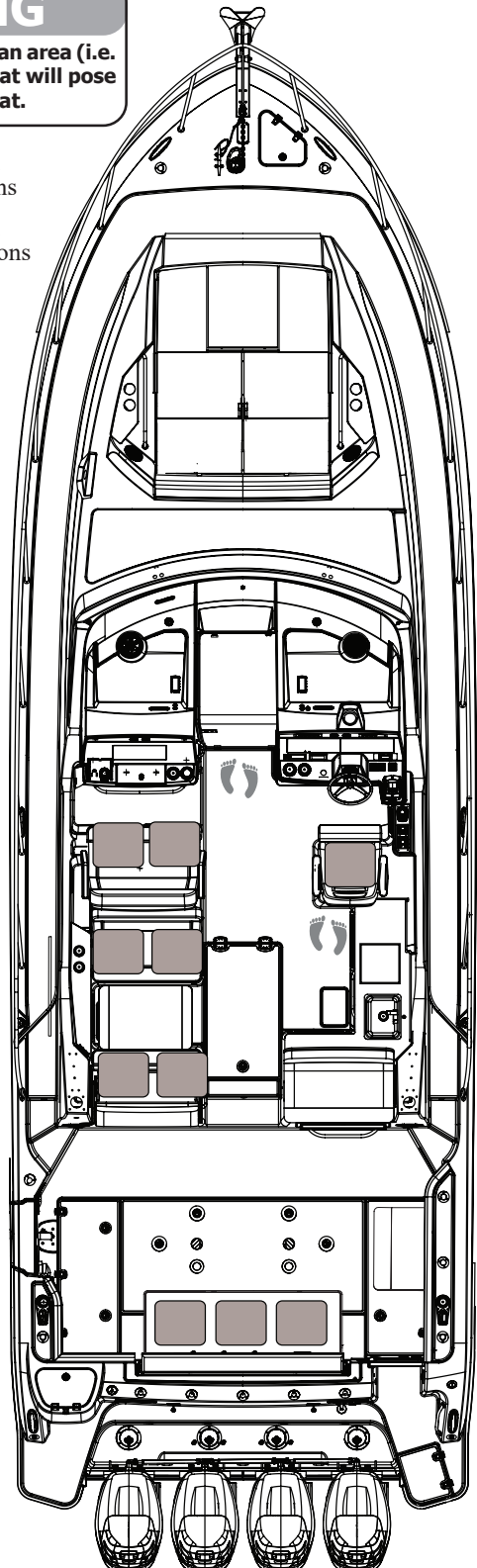

Recommended occupant locations on-plane

NOTE: Hardtop not shown.

NOTE: Additional passenger locations below deck.

Thru-hull Fitting Locations

Thru-hull Fittings
Figure 2.9.1

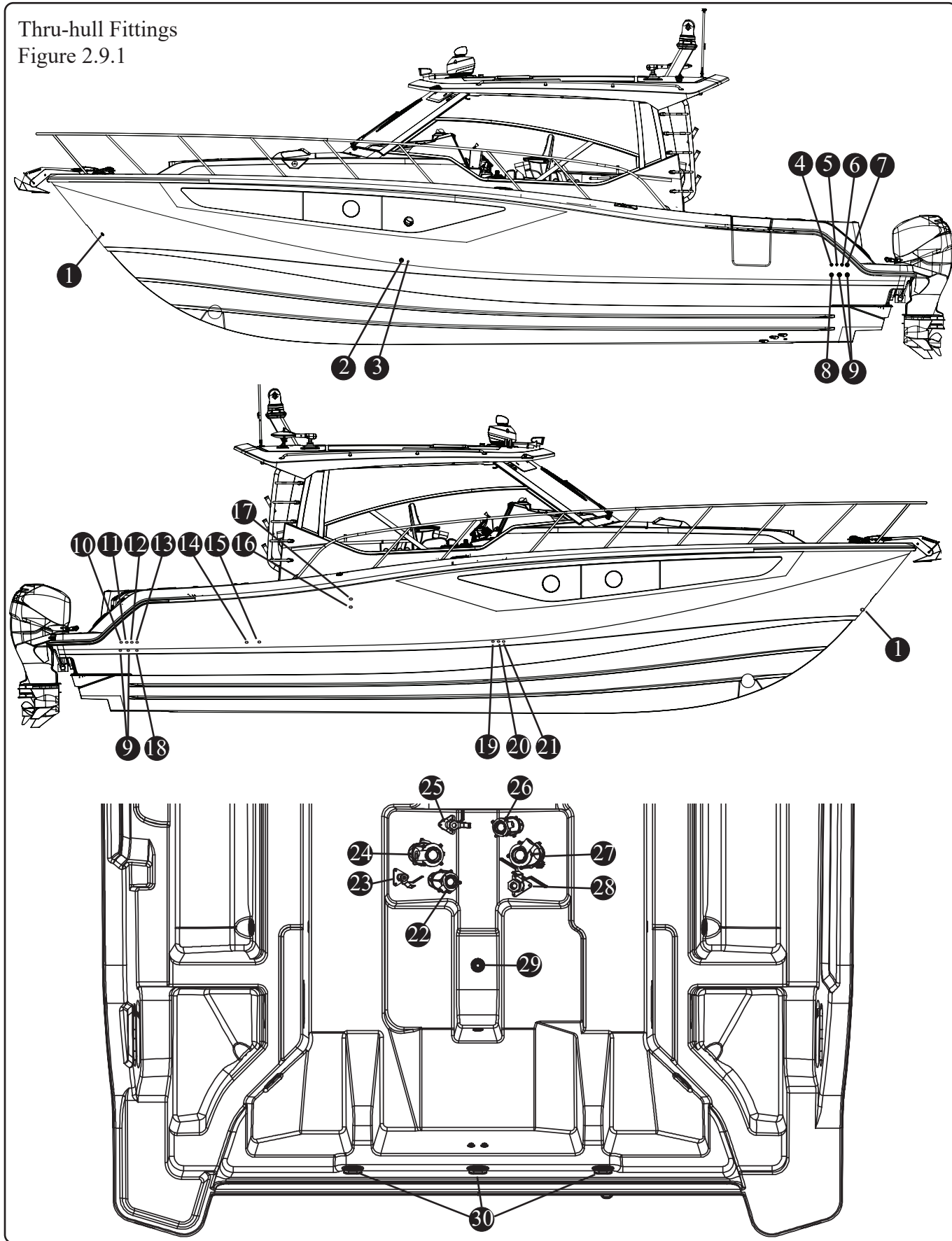

Thru-hull Fittings (see Figure 2.9.1)

1 ANCHOR LOCKER DRAIN	16 HEATER EXHAUST (OPTION)
2 HEAD & GALLEY SINK DRAINS, CABIN A/C	17 WASTE SYSTEM VENT
3 MAIN CABIN A/C	18 GENERATOR
4 SUMMER KITCHEN SINK DRAIN (OPTION)	19 FORWARD BILGE PUMP
5 BILGE PUMP	20 SUMP
6 FISHBOX PUMPOUT	21 FORWARD STATEROOM A/C
7 LIVEWELL DRAIN	22 GENERATOR PICKUP
8 LIVEWELL DRAIN (OPTION)	23 LIVEWELL AND RAW WATER PICKUP
9 DECK DRAIN	24 A/C SYSTEM PICKUP
10 REFRIGERATION DRAIN (OPTION)	25 LIVEWELL PICKUP (OPTION)
11 FISHBOX PUMPOUT	26 GYROSCOPIC STABILIZER PICKUP (OPTION)
12 BILGE PUMP	27 A/C & CHILLER SYSTEMS' PICKUP
13 GYROSCOPIC STABILIZER DRAIN (OPTION)	28 WASTE SYSTEM DISCHARGE
14 A/C, WATER HEATER	29 TRANSDUCER
15 PREP STATION SINK, COMMON DRAINS	30 SPLASHWELL DRAIN

NOTICE

- The deck drains provide self-bailing capabilities while the boat is static in the water and no passengers on board. This feature prevents the accumulation of water in the cockpit.
- Depending on the type of boat, you may have underwater fittings that need drain plugs. Garboard drain plugs and fishbox drain plugs need to be in place before the boat goes into the water. Any fitting that will be underwater needs to be plugged or the seacock needs to be closed.
- Through hull fittings and deck drain scupper flaps should be checked for proper seal annually. When the boat is in the water the underwater fittings can be checked for dripping. It is recommended that the underwater fittings be removed, cleaned and resealed every other year.
- If the through hull fittings need to be replaced, it is recommended that an authorized Boston Whaler dealer perform this type of repair. Through hull fittings that are improperly installed can cause premature hull failure and may void the Boston Whaler limited warranty.

Features

Deck
Figure 2.11.1

- 1 ANCHOR
- 2 BOW RAIL
- 3 CLEAT
- 4 WINDLASS
- 5 DECK HATCH
- 6 SPEAKER
- 7 SKYLIGHT
- 8 CABIN ENTRY DOOR
- 9 CONVERTIBLE LOUNGE SEATING
- 10 CONVERTIBLE LOUNGE TABLE
- 11 FUEL FILL
- 12 FISHBOX
- 13 AFT MECHANICAL ACCESS HATCH
- 14 HAWSE PIPE W/ CUPHOLDER
- 15 FRESHWATER FILL
- 16 LIVEWELL
- 17 WASTE PUMPOUT
- 18 ANCHOR LOCKER
- 19 TILT-UP BOW LOUNGE
- 20 GRAB RAIL
- 21 SPEAKER
- 22 PREP STATION WITH SINK
- 23 STBD FUEL TANK INSPECTION COVER*
- 24 FORWARD MECHANICAL ACCESS HATCH
- 25 FOLD-DOWN SEAT
- 26 FOLD-DOWN SEAT (OPTION)
- 27 GENERATOR FUEL FILL
- 28 REBOARDING LADDER
- 29 GRILL

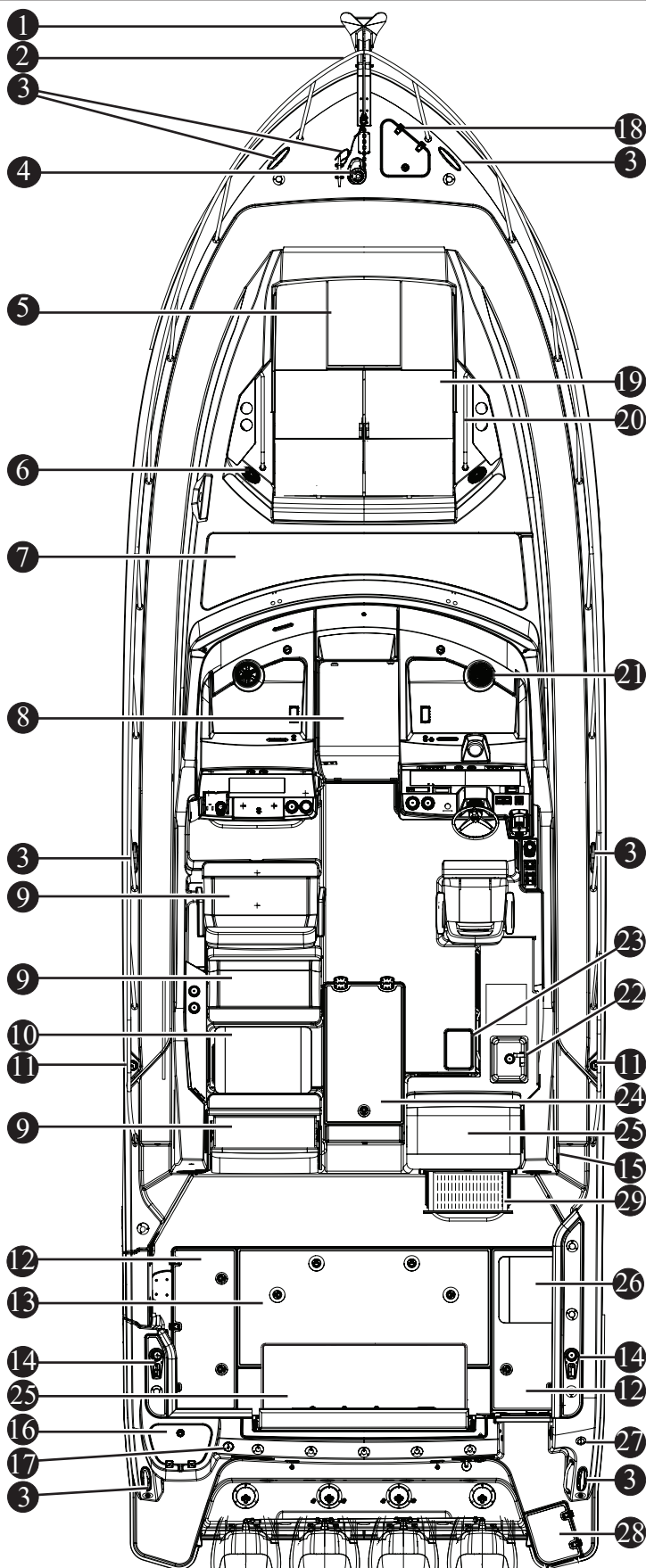

*NOTE: Port fuel tank inspection cover not shown.

Bow Equipment
Figure 2.12.1

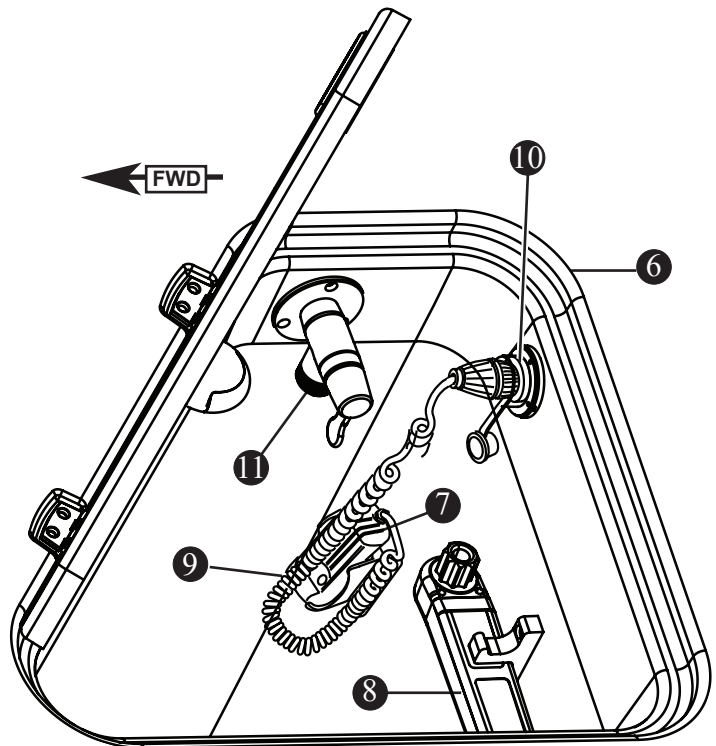
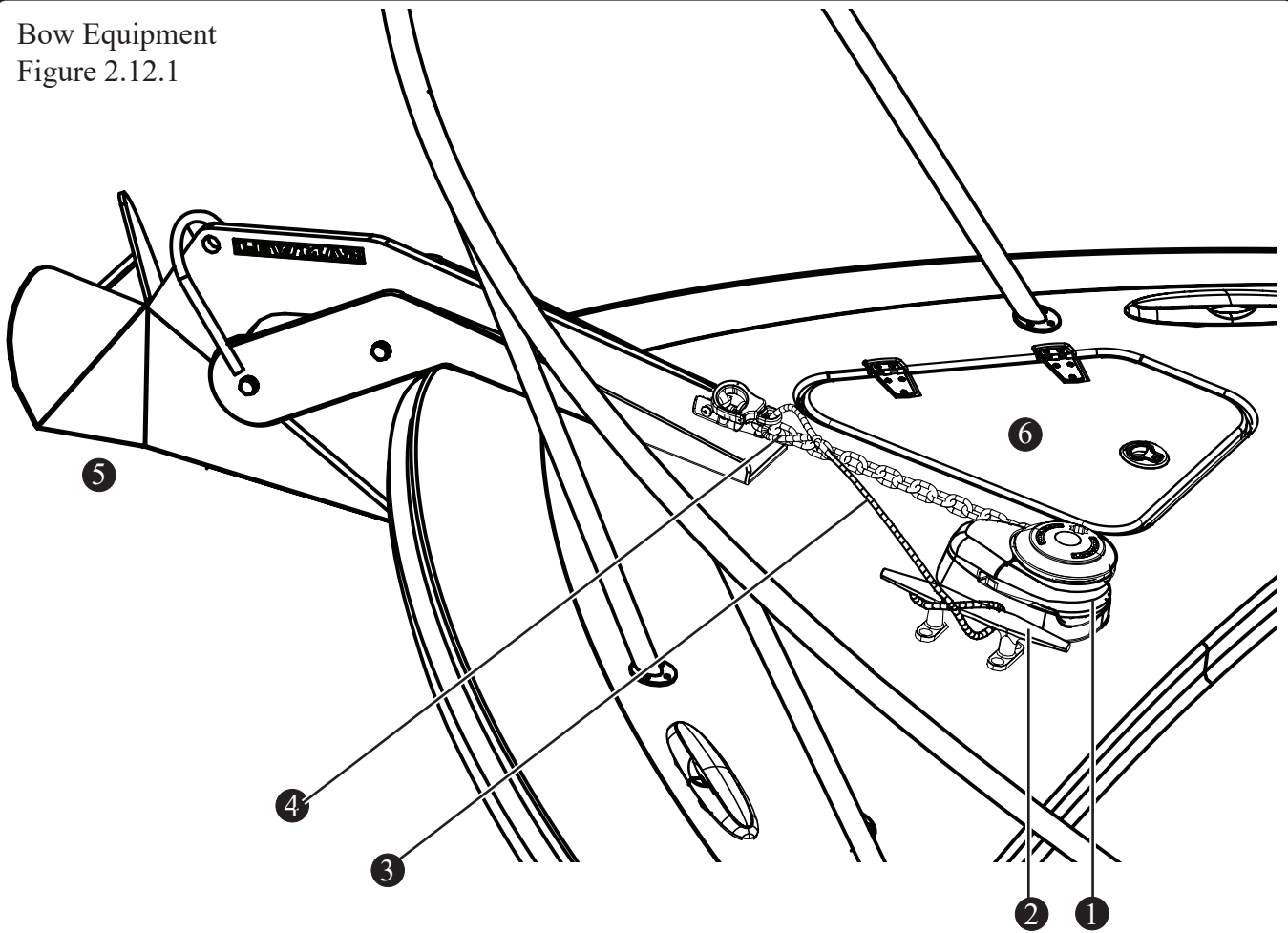

- 1 WINDLASS
- 2 CLEAT
- 3 ANCHOR LANYARD
- 4 CHAIN RODE
- 5 ANCHOR
- 6 ANCHOR LOCKER
- 7 WINDLASS REMOTE
- 8 EMERGENCY HANDLE
- 9 REMOTE CABLE
- 10 REMOTE INLET
- 11 FRESHWATER FAUCET

Helm
Figure 2.13.1

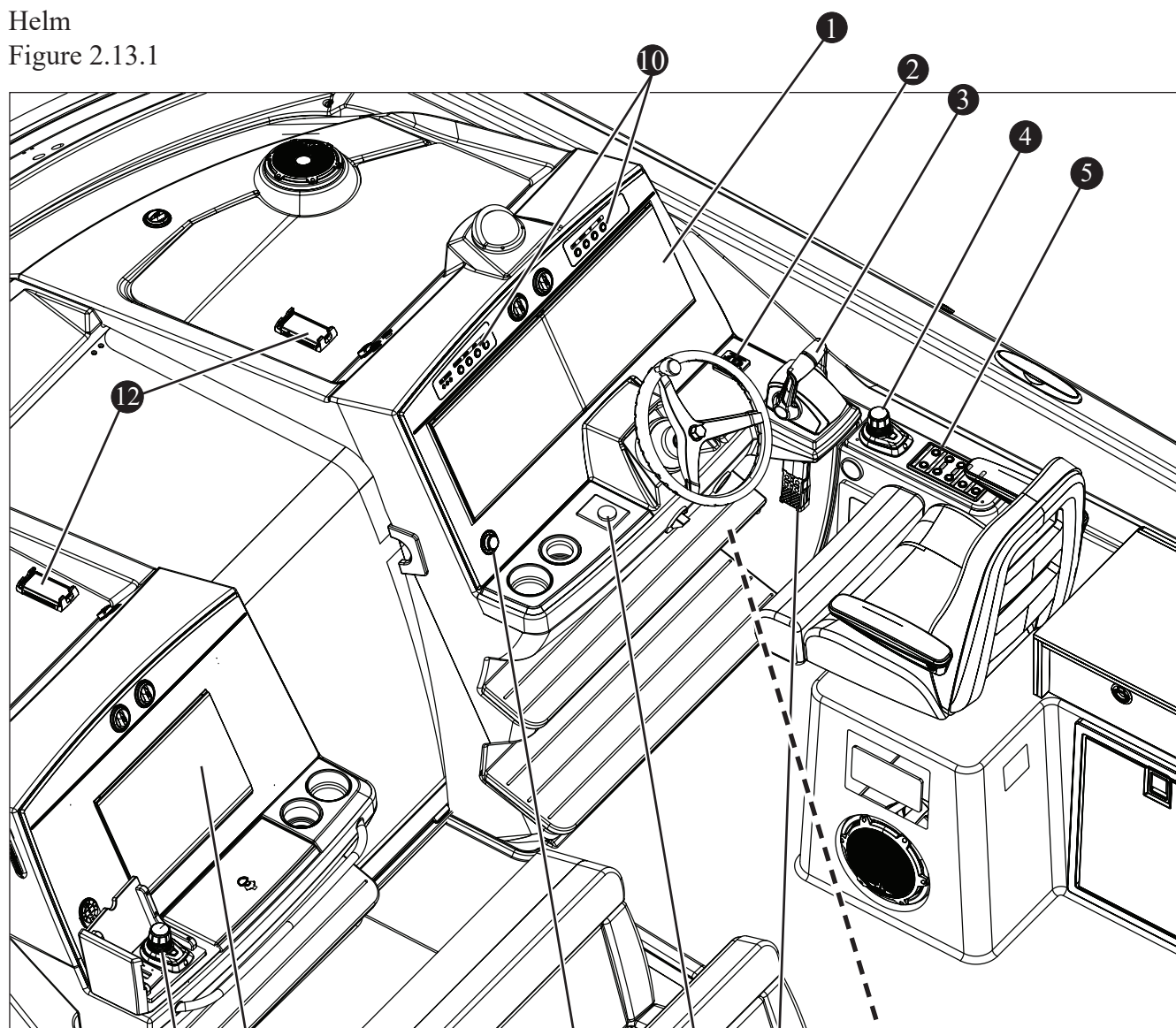

- | | |
|-----------------------------------|---------------------------|
| 1 HELM DISPLAY | 9 STEREO CONTROL |
| 2 TRIM TAB SWITCHES | 10 HELM SWITCH PANEL |
| 3 THROTTLE & SHIFT CONTROL | 11 HELM DISPLAY (OPTION) |
| 4 JOYSTICK PILOTING | 12 PHONE CHARGER |
| 5 STARBOARD SWITCH PANEL | 13 VHF RADIO HANDSET |
| 6 FIRE SUPPRESSION SYSTEM MONITOR | 14 HELM DISPLAY CARD PORT |
| 7 ENGINE EMERGENCY STOP SWITCH | 15 ENGINE DIAGNOSTIC PORT |
| 8 SPOTLIGHT CONTROL | |

Cockpit Ice Maker (Option)
Figure 2.14.1

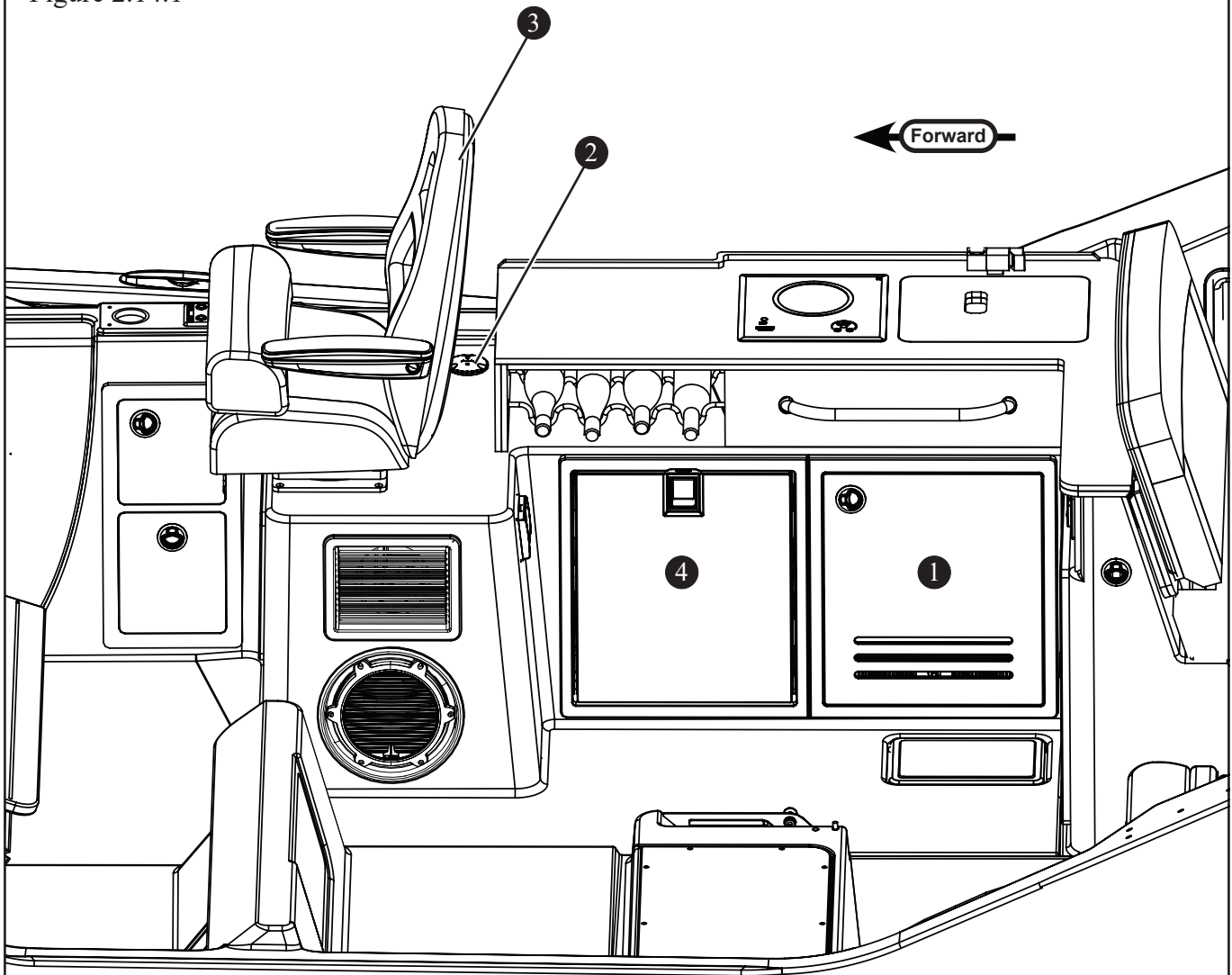

1 ICE MAKER¹ (OPTION)

3 HELM SEAT

2 ICE MAKER WATER FILL (OPTION)

4 REFRIGERATOR

¹DRAWERS ARE STANDARD IN THIS LOCATION; FREEZER IS ALSO AN OPTION.

Helm Switch Panels
Figure 2.15.1

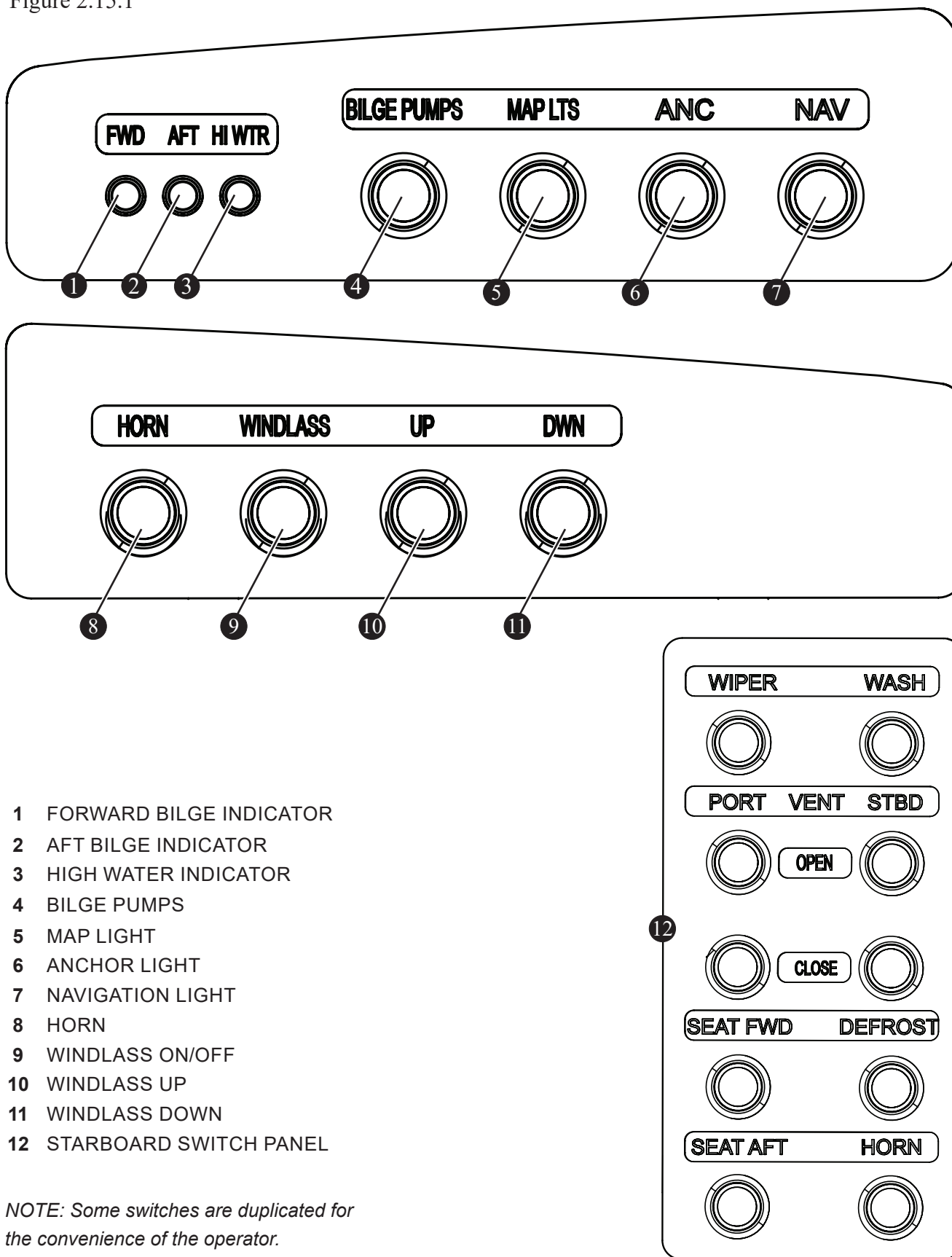

- 1 FORWARD BILGE INDICATOR
- 2 AFT BILGE INDICATOR
- 3 HIGH WATER INDICATOR
- 4 BILGE PUMPS
- 5 MAP LIGHT
- 6 ANCHOR LIGHT
- 7 NAVIGATION LIGHT
- 8 HORN
- 9 WINDLASS ON/OFF
- 10 WINDLASS UP
- 11 WINDLASS DOWN
- 12 STARBOARD SWITCH PANEL

NOTE: Some switches are duplicated for the convenience of the operator.

Footrests, Fold-down and Pull-out
Figure 2.16.1

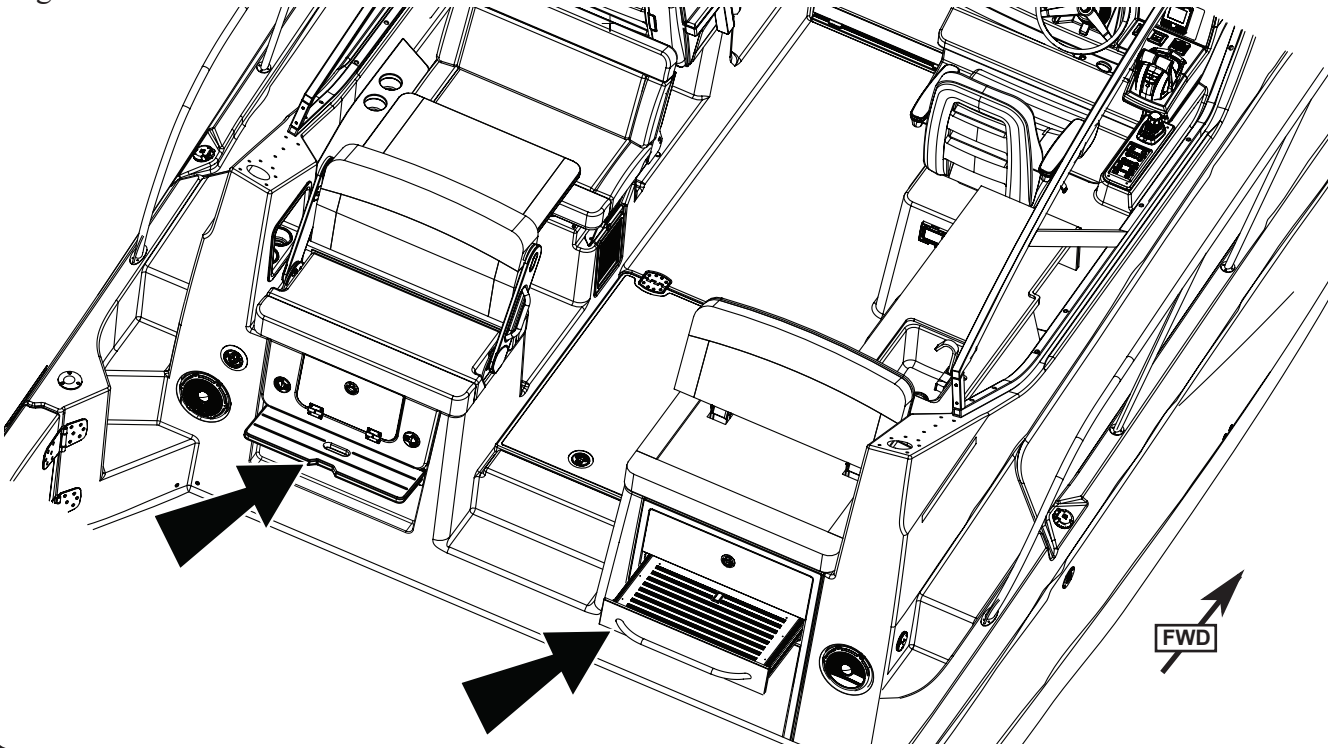

Freshwater Showers
Figure 2.16.2

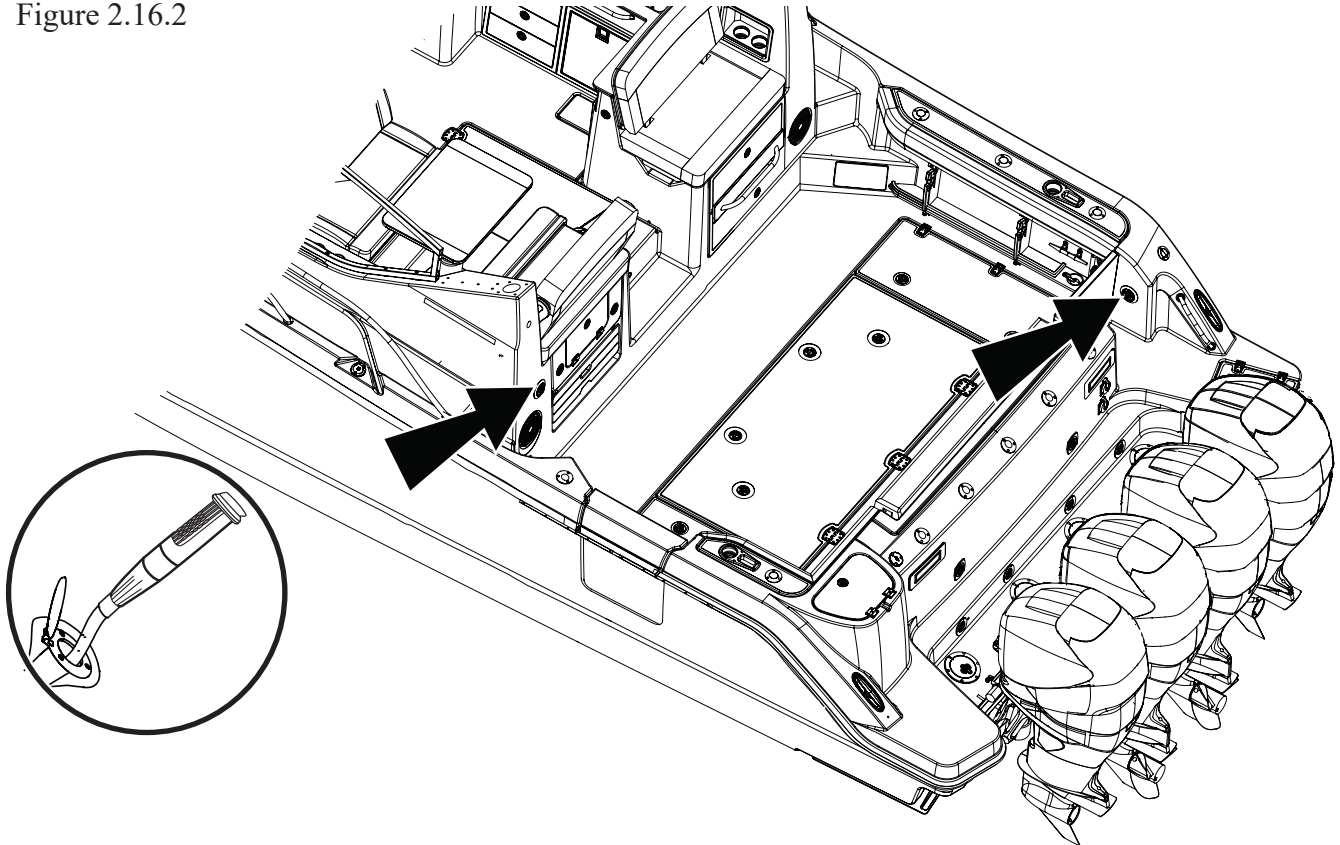

Transom
Figure 2.17.1

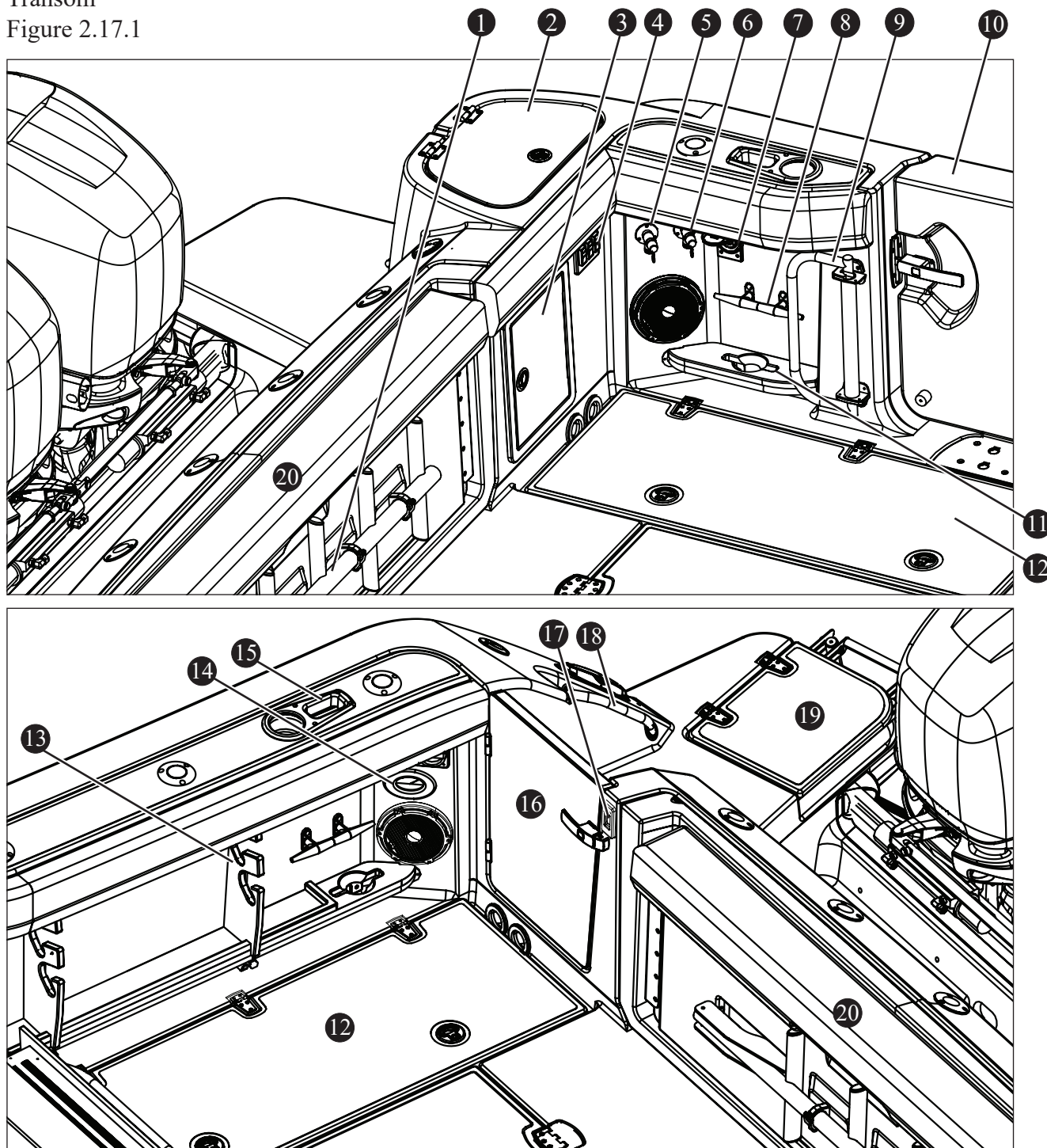

- | | | |
|-------------------------------|-----------------------------|--------------------------|
| 1 DIVE LADDER | 8 CLEAT | 15 HAWSE PIPE |
| 2 LIVEWELL | 9 SWIVEL GRAB HANDLE | 16 TRANSOM DOOR |
| 3 GEN. COOLANT EXPANSION TANK | 10 DIVE DOOR | 17 COURTESY LIGHT SWITCH |
| 4 LIVEWELL/FISHBOX SWITCHES | 11 DOWNRIGGER WEIGHT HOLDER | 18 GRAB HANDLE |
| 5 RAW WATER FAUCET | 12 FISHBOX | 19 REBOARDING LADDER |
| 6 FRESHWATER FAUCET | 13 ROD OR BOAT HOOK RACK | 20 FOLD-DOWN BENCH |
| 7 ELECTRIC REEL RECEPTACLE | 14 ROD OR BOAT HOOK SLOT | |

Transom (Continued)
Figure 2.18.1

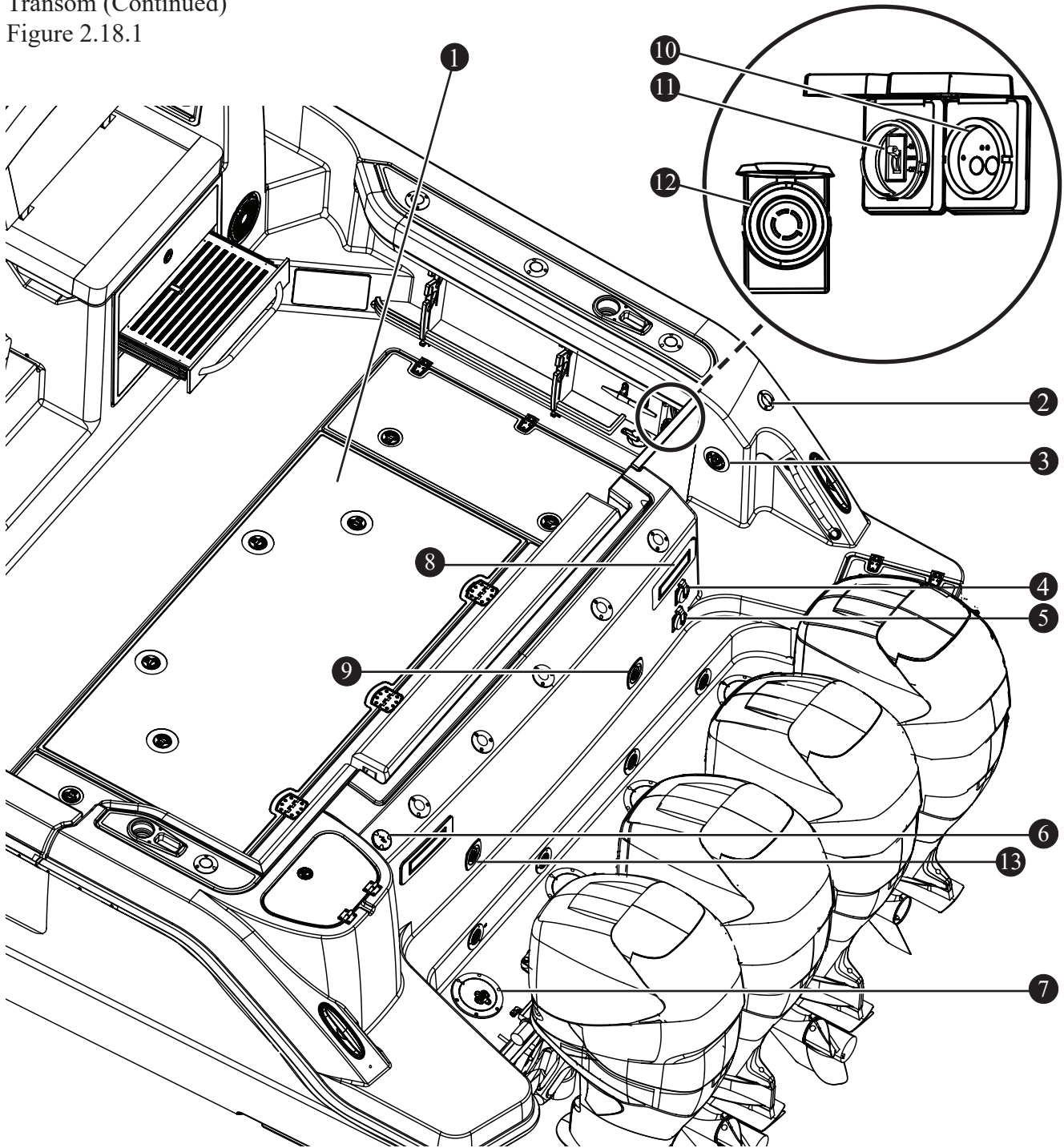

- | | | | |
|---|-----------------------------|----|---------------------------------------|
| 1 | AFT MECHANICAL ACCESS HATCH | 8 | BILGE VENT (2) |
| 2 | DIESEL FUEL FILL | 9 | ENGINE FLUSH CONNECTION |
| 3 | FRESHWATER SHOWER | 10 | EQUIPMENT LEAKAGE CIRCUIT INTERRUPTER |
| 4 | CABLE TV INLET | 11 | SHORE POWER INLET BREAKER |
| 5 | SHORE POWER INLET | 12 | ELECTRIC REEL RECEPTACLE (OPTION) |
| 6 | WASTE PUMPOUT | 13 | DOCKSIDE WATER CONNECT |
| 7 | ACCESS PLATE | | |

Transom/Hull
Figure 2.19.1

! CAUTION
Do not use underwater lights when navigational lights are in use as this may interfere with the effectiveness of the navigational lights.

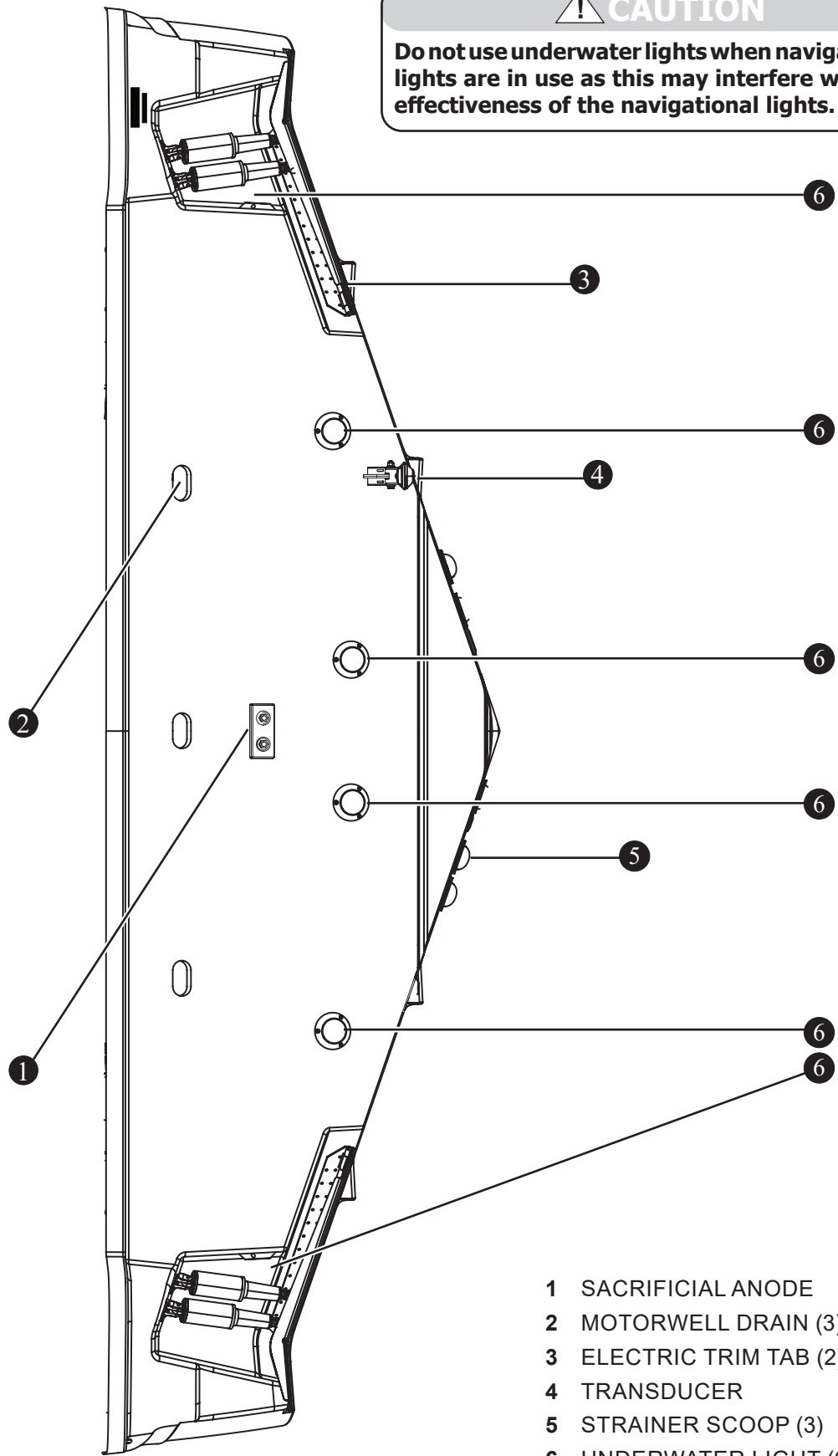

- 1 SACRIFICIAL ANODE
- 2 MOTORWELL DRAIN (3)
- 3 ELECTRIC TRIM TAB (2)
- 4 TRANSDUCER
- 5 STRAINER SCOOP (3)
- 6 UNDERWATER LIGHT (6)

Hardtop
Figure 2.20.1

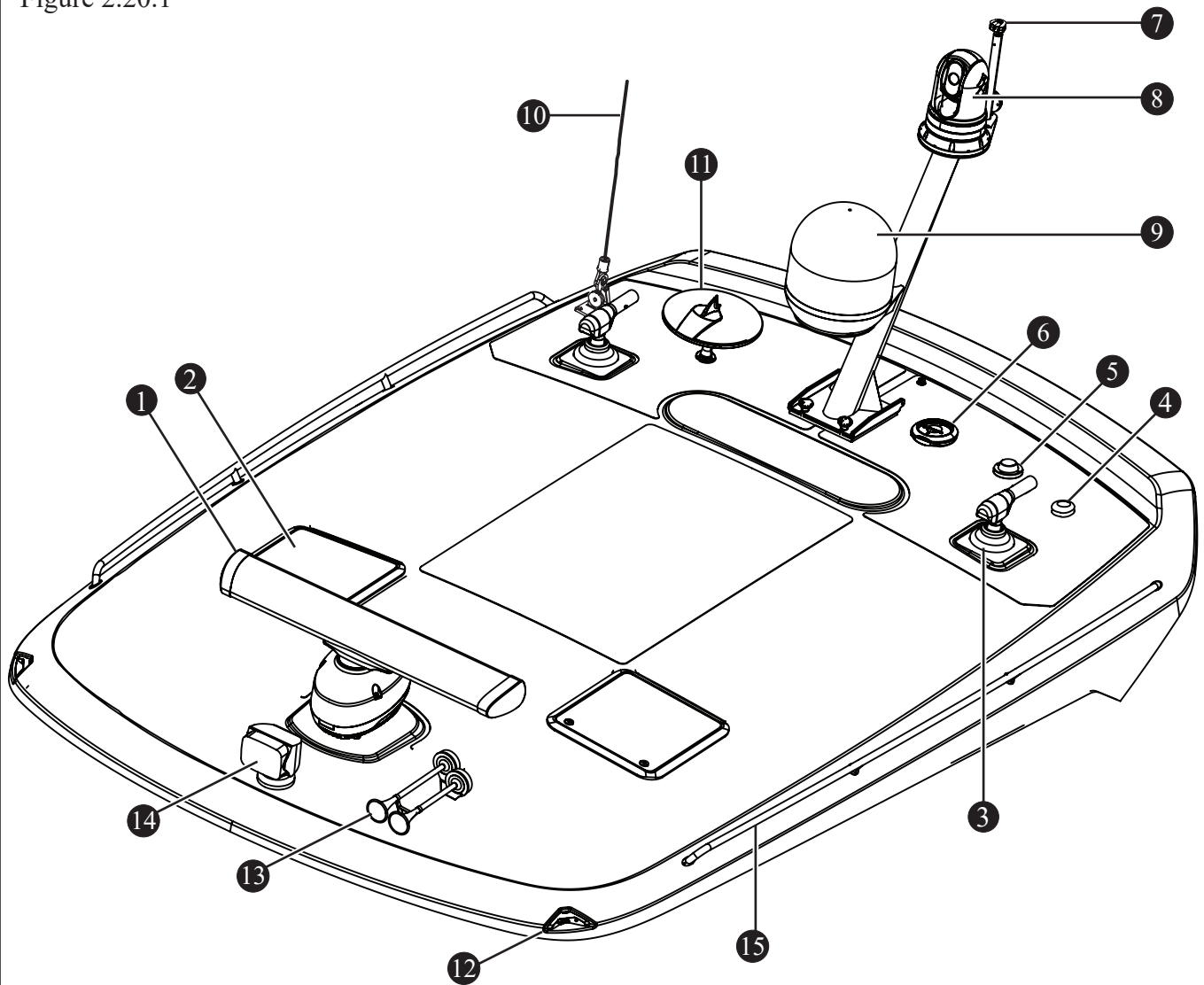

- | | |
|---------------------------------|------------------------------|
| 1 RADAR ARRAY (OPTION) | 9 SATELLITE TV (OPTION) |
| 2 HARDTOP HATCH (2) | 10 VHF ANTENNA |
| 3 RADIAL OUTRIGGER (2) (OPTION) | 11 TV ANTENNA |
| 4 AIS ANTENNA (OPTION) | 12 NAVIGATION SIDE LIGHT (2) |
| 5 SATELLITE ANTENNA (OPTION) | 13 HORN |
| 6 GPS ANTENNA (OPTION) | 14 SPOTLIGHT (OPTION) |
| 7 ALL ROUND (ANCHOR) LIGHT | 15 HANDRAIL (2) |
| 8 INFRARED CAMERA (OPTION) | |

Hardtop (Underside)
Figure 2.21.1

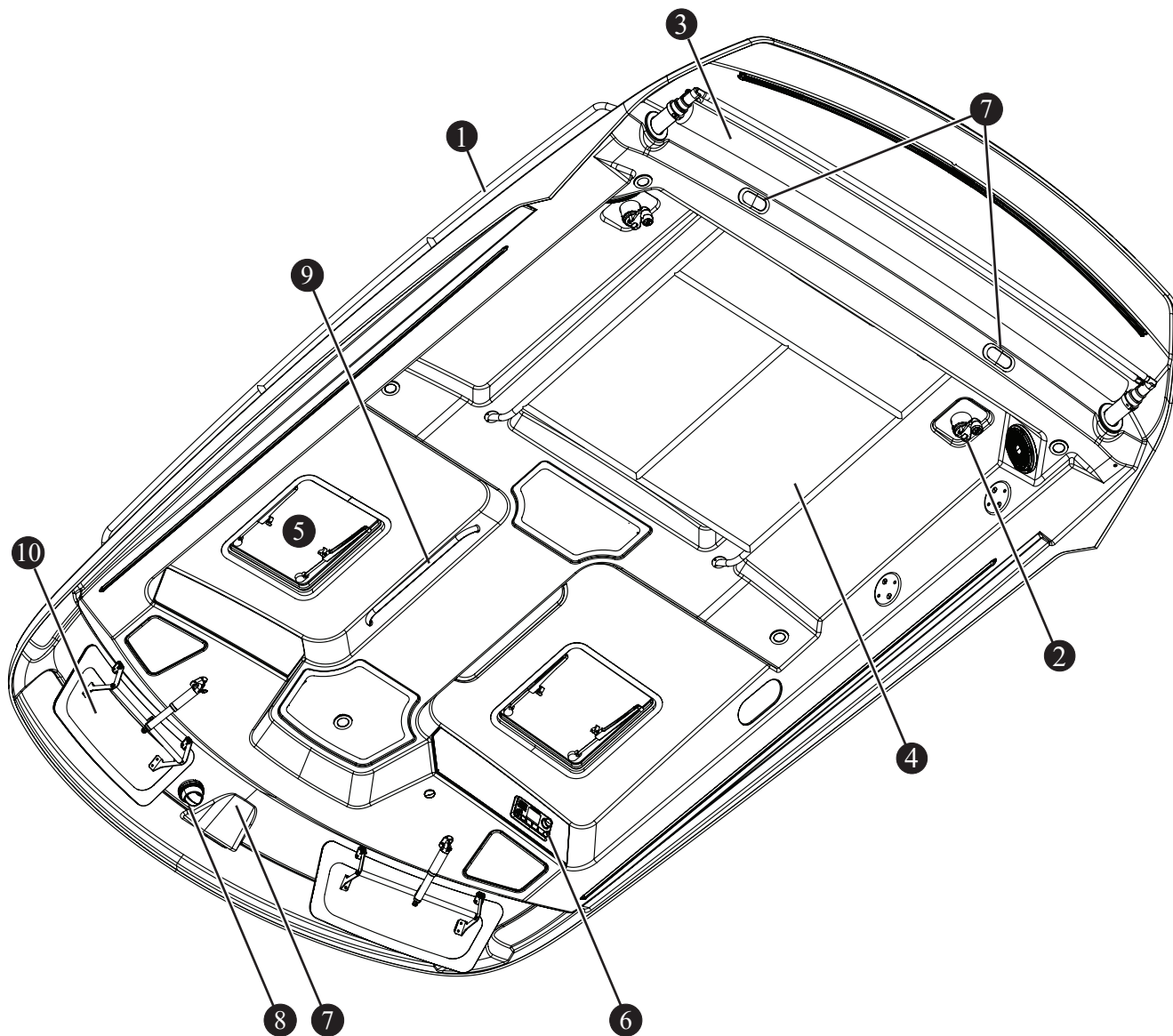

- 1 HARDTOP HANDRAILS (2)
- 2 RADIAL OUTRIGGER (OPTION)
- 3 POWERED SUN SHADE
- 4 CANVAS STORAGE
- 5 HATCH (2)

- 6 VHF RADIO
- 7 FLOODLIGHT (3)
- 8 CAMERA (OPTION)
- 9 HANDRAIL (2)
- 10 VENT (2)

Navigation Lighting

ATTENTION

The improper sequence of navigation lighting may be as dangerous as no lighting at all.

This vessel comes equipped with navigation lighting for your safety. Regulations state that all boats must display navigation lights between sunset and sunrise and during periods of restricted visibility, such as rain, fog, haze, etc. If operating in reduced visibility or between sunset and sunrise it is necessary to maintain a safe speed and post a lookout.

It is the operator's responsibility to ensure that the navigation lights are in good working order and that the proper lighting is shown and not obstructed in its intended arc of visibility. Do not modify navigation lights. This vessel's navigation lights may include an expiration date on the housing. If one is located, replace light before expiration date, even if light is functional, as lighting quality may be compromised.

Do not add lights that interfere with required navigation lights. Some lights, such as blue colored lights, may be illegal to display on a boat. It is the owner's responsibility to ensure that displayed lights are also compliant with local regulations.

Operating the Navigation Lighting

A three-position switch, located on the console switch panel marked *NAV/ANC* controls the navigation and anchor lighting (see Figure 2.22.1).

NAV/ANC Switch

Figure 2.22.1

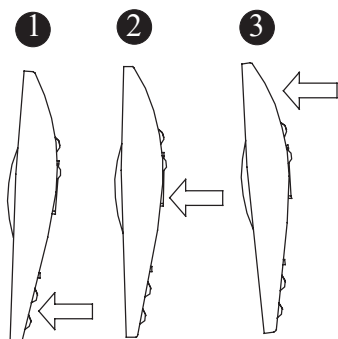

- ① ANCHOR LIGHT "ON"
- ② "OFF"
- ③ NAVIGATIONAL LIGHTS "ON"

Navigation/Anchor Lighting Figure 2.22.2

112.5° PORT
NAVIGATION
SIDE LIGHT (RED)
VISIBLE 1 NM

112.5° STARBOARD
NAVIGATION SIDE
LIGHT (GREEN)
VISIBLE 1 NM

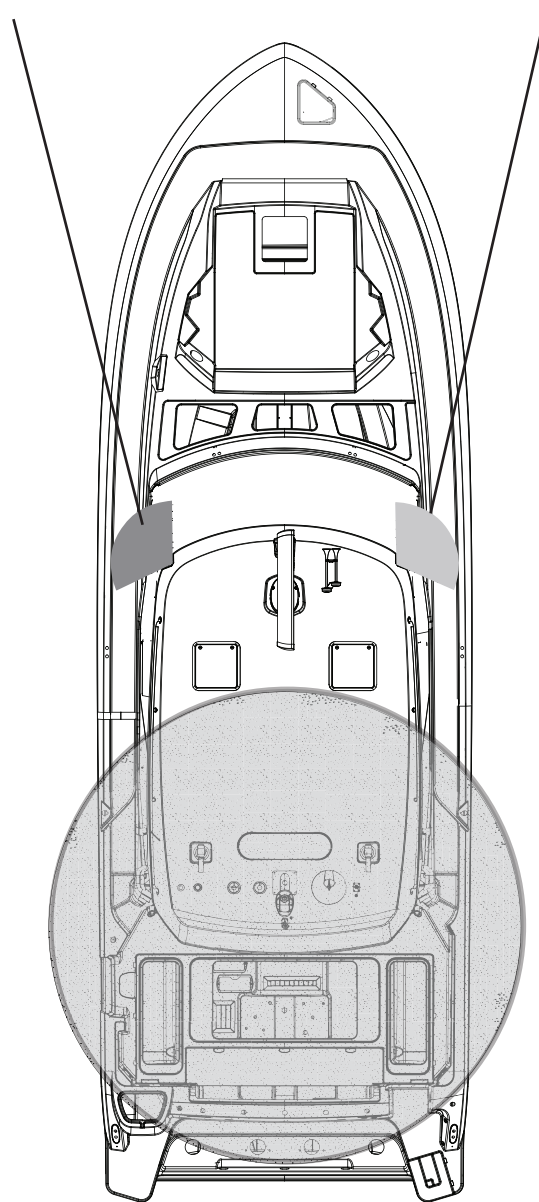

360° ALL-AROUND LIGHT (WHITE) VISIBLE 2 NM

! CAUTION

Do not use accent lights when navigational lights are in use as this may interfere with the effectiveness of the navigational lights.

Mechanical Access Hatches
Figure 2.23.1

Forward Mechanical Access Hatch

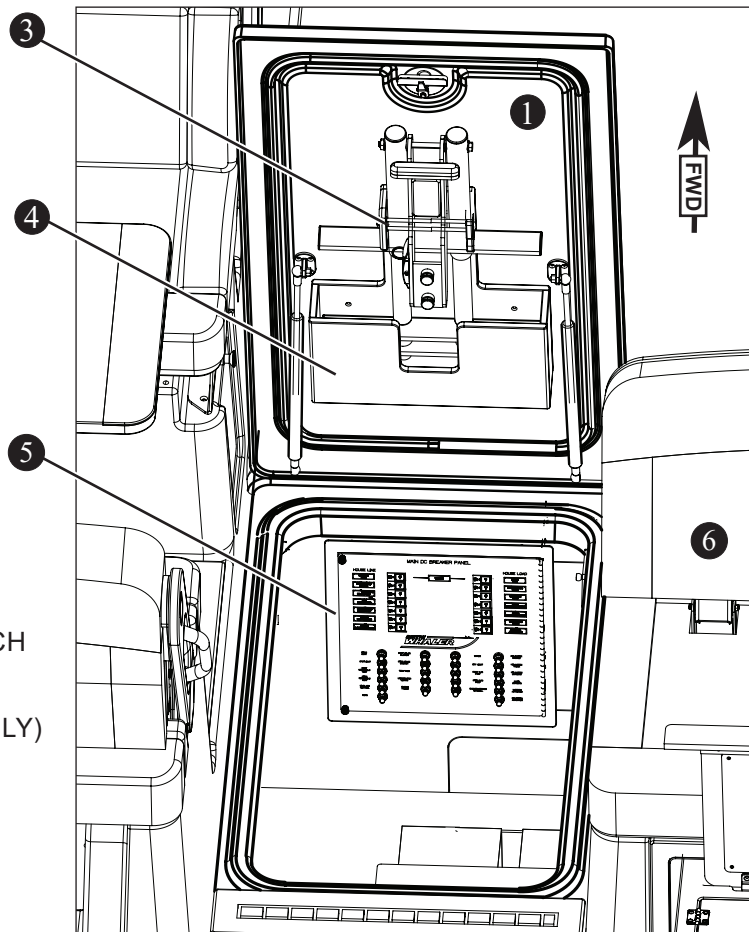

- 1 FORWARD MECHANICAL ACCESS HATCH
- 2 AFT MECHANICAL ACCESS HATCH
- 3 DIVE LADDER (SUMMER KIT. OPTION ONLY)
- 4 DIVE LADDER HOLDER
- 5 MAIN DC BREAKER PANEL
- 6 REAR-FACING SEAT
- 7 FRESHWATER FILL

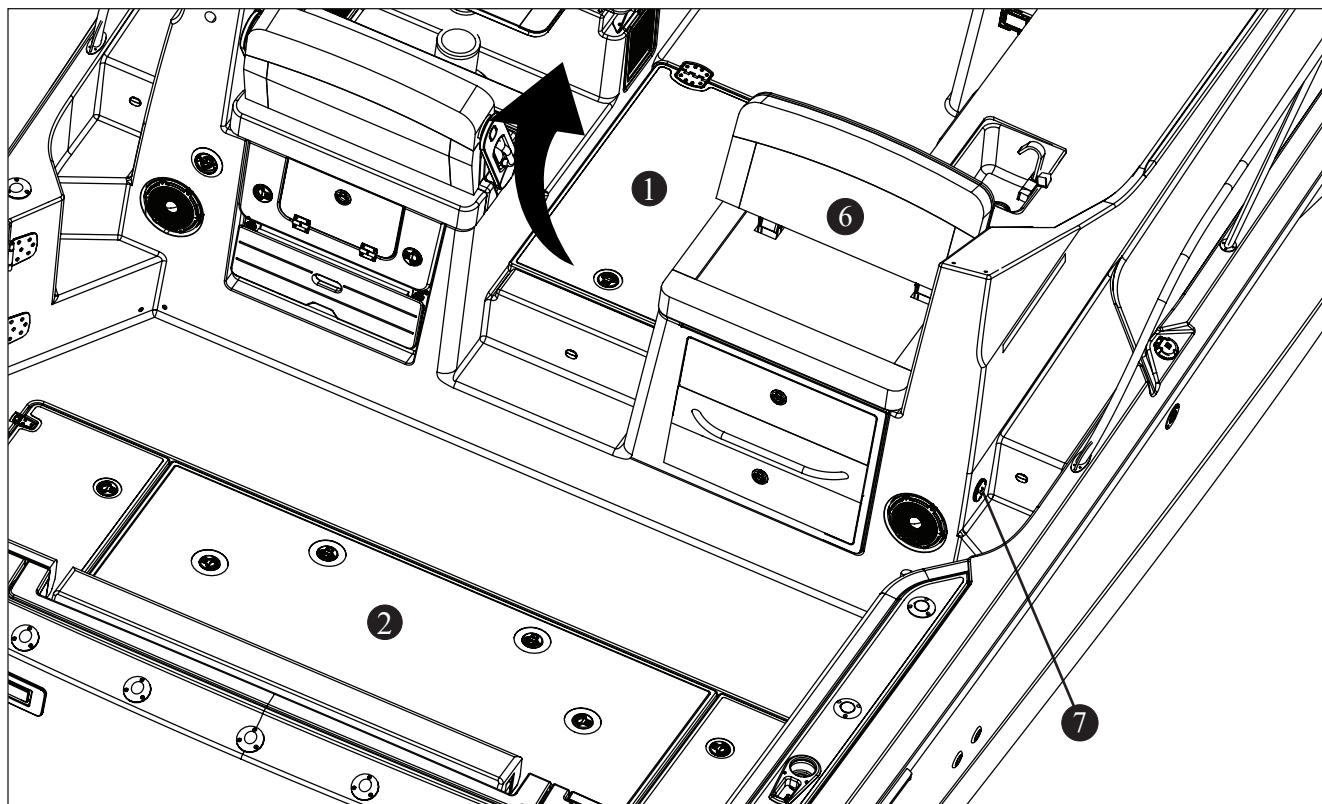

Mechanical Access Hatches (Continued)

Figure 2.24.1

Forward Mechanical Access Hatch

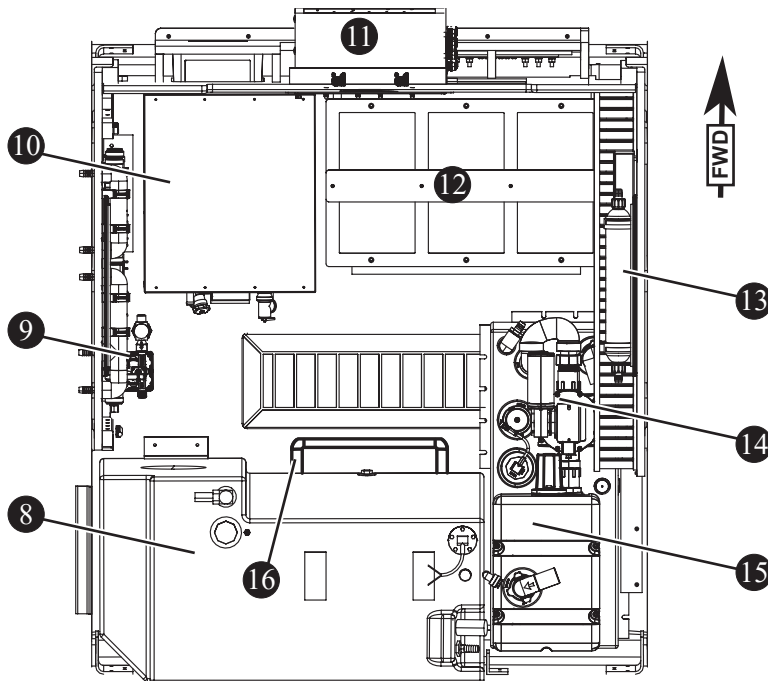

Aft Mechanical Access Hatch

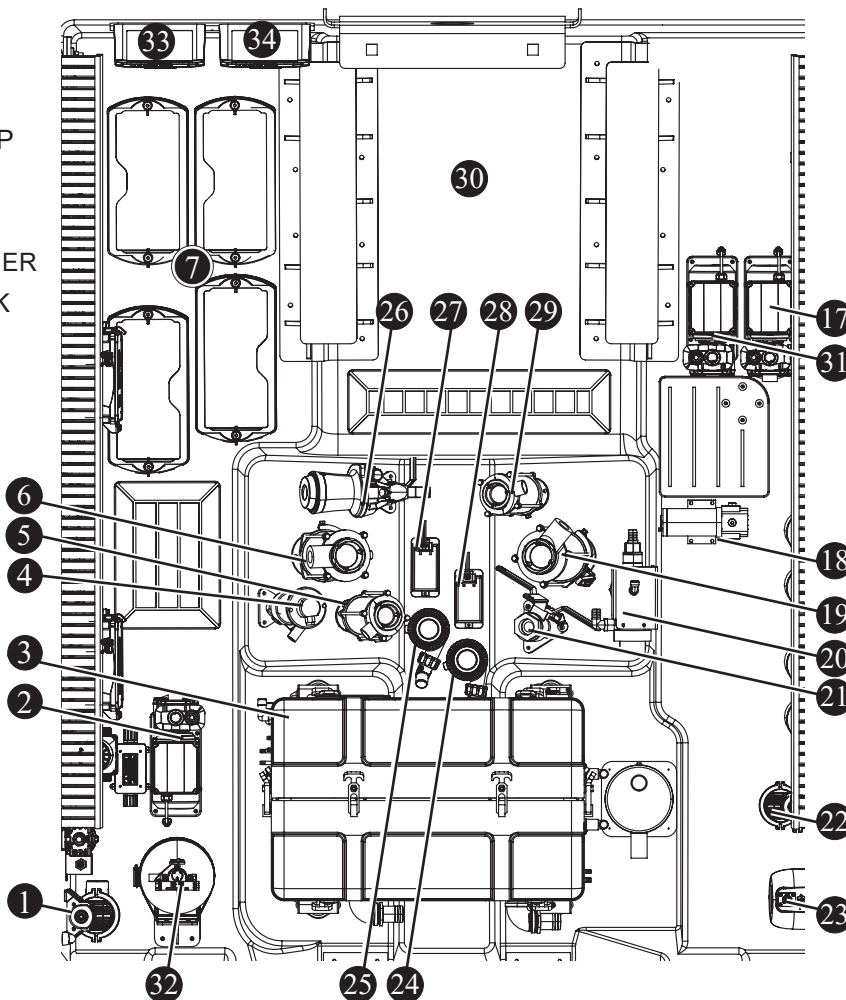

- 1 PORT FISHBOX PUMP
- 2 CABIN A/C PUMP
- 3 GENERATOR
- 4 LIVWELL PUMP
- 5 GENERATOR STRAINER
- 6 CABIN A/C STRAINER
- 7 BATTERY TRAYS (ENGINE)
- 8 FRESHWATER TANK
- 9 FRESHWATER PUMP
- 10 WATER HEATER
- 11 MAIN DC BREAKER PANEL
- 12 BATTERY TRAYS (HOUSE)
- 13 HEAD IN-LINE FILTER
- 14 WASTE VACUUM SYSTEM
- 15 WASTE HOLDING TANK
- 16 RUNG LADDER
- 17 A/C & CHILLER SYSTEMS' PICKUP
- 18 AUTOPILOT PUMP
- 19 COCKPIT A/C STRAINER
- 20 BOOST PUMP & SEAWATER STRAINER
- 21 LOCKABLE DISCHARGE SEACOCK
- 22 STBD FISHBOX PUMP
- 23 ENGINE FLUSH (OPTION)
- 24 BILGE PUMP
- 25 BILGE PUMP
- 26 LIVWELL PUMP (OPTION)
- 27 BILGE PUMP FLOAT SWITCH
- 28 BILGE PUMP FLOAT SWITCH
- 29 GYRO STABILIZER STRAINER (OPTION)
- 30 GYRO STABILIZER (OPTION)
- 31 GYRO STABILIZER PUMP (OPTION)
- 32 FIRE EXTINGUISHER
- 33 PORT ENGINE BATTERY CHARGER
- 34 STDB ENGINE BATTERY CHARGER

Aft Mechanical Access Hatch
Figure 2.25.1

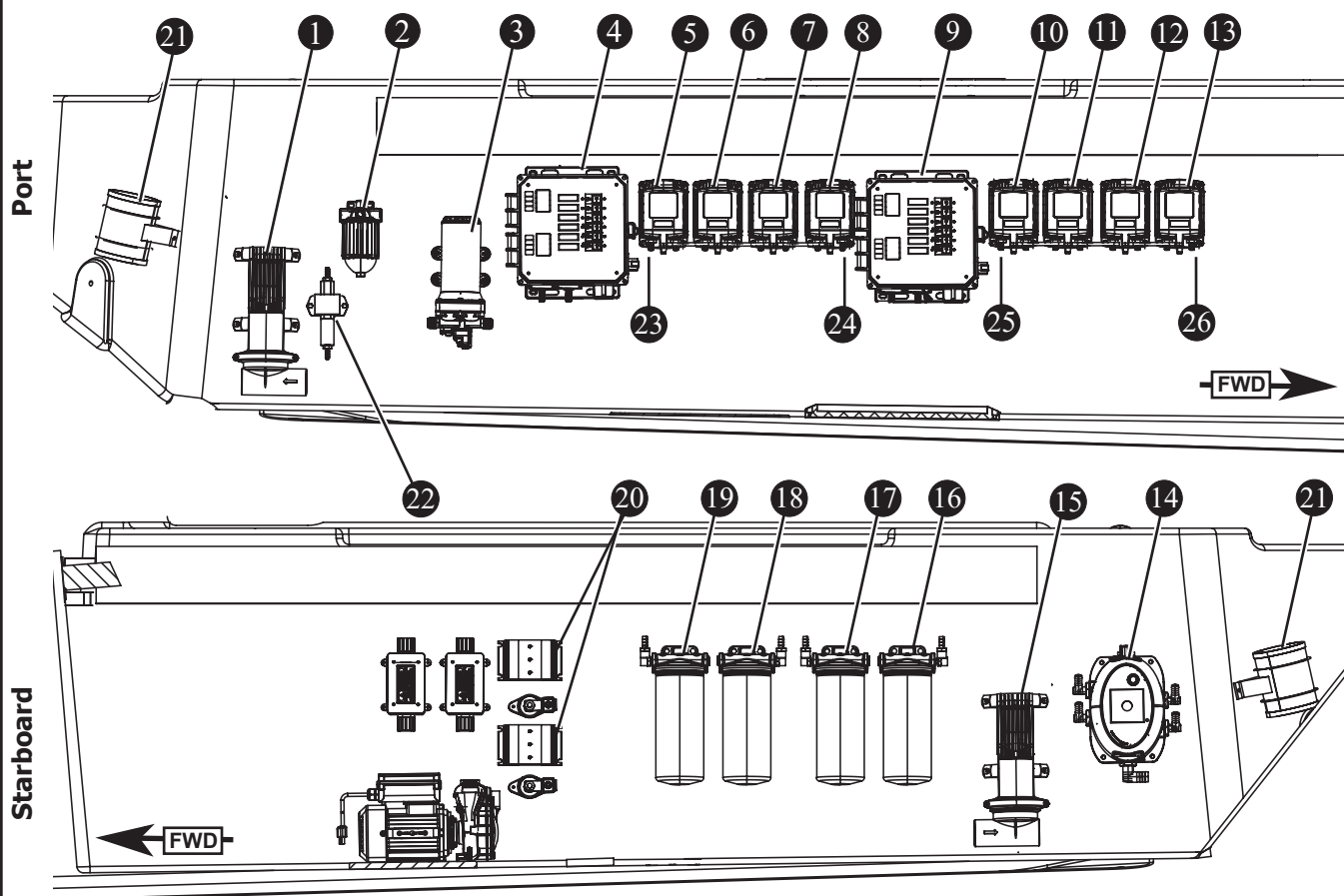

- | | | | |
|----|--------------------------------------|----|--|
| 1 | PORT FISHBOX PUMP | 14 | ENGINE FLUSH (OPTION) |
| 2 | GENERATOR FUEL FILTER | 15 | STBD FISHBOX PUMP |
| 3 | RAW WATER PUMP | 16 | STBD OUTER FUEL FILTER |
| 4 | PORT ENGINE BREAKER PANEL | 17 | STBD CENTER FUEL FILTER |
| 5 | PORT ENGINE REMOTE BATTERY SWITCH | 18 | PORT CENTER FUEL FILTER |
| 6 | PORT ENGINE AUTOMATIC CHARGING RELAY | 19 | PORT OUTER FUEL FILTER |
| 7 | PORT CENTER AUTOMATIC CHARGING RELAY | 20 | AUTO POWER SELECTOR |
| 8 | PORT CENTER REMOTE BATTERY SWITCH | 21 | BILGE BLOWER |
| 9 | STBD ENGINE BREAKER PANEL | 22 | GENERATOR FUEL PUMP AND PRE-FILTER |
| 10 | STBD ENGINE REMOTE BATTERY SWITCH | 23 | PORT ENGINE MASTER IGNITION (1A FUSE) |
| 11 | STBD ENGINE AUTOMATIC CHARGING RELAY | 24 | PORT CENTER ENGINE MASTER IGNITION (1A FUSE) |
| 12 | STBD CENTER AUTOMATIC CHARGING RELAY | 25 | STBD ENGINE MASTER IGNITION (1A FUSE) |
| 13 | STBD CENTER REMOTE BATTERY SWITCH | 26 | STBD CENTER ENGINE MASTER IGNITION (1A FUSE) |

Cabin Salon
Figure 2.26.1

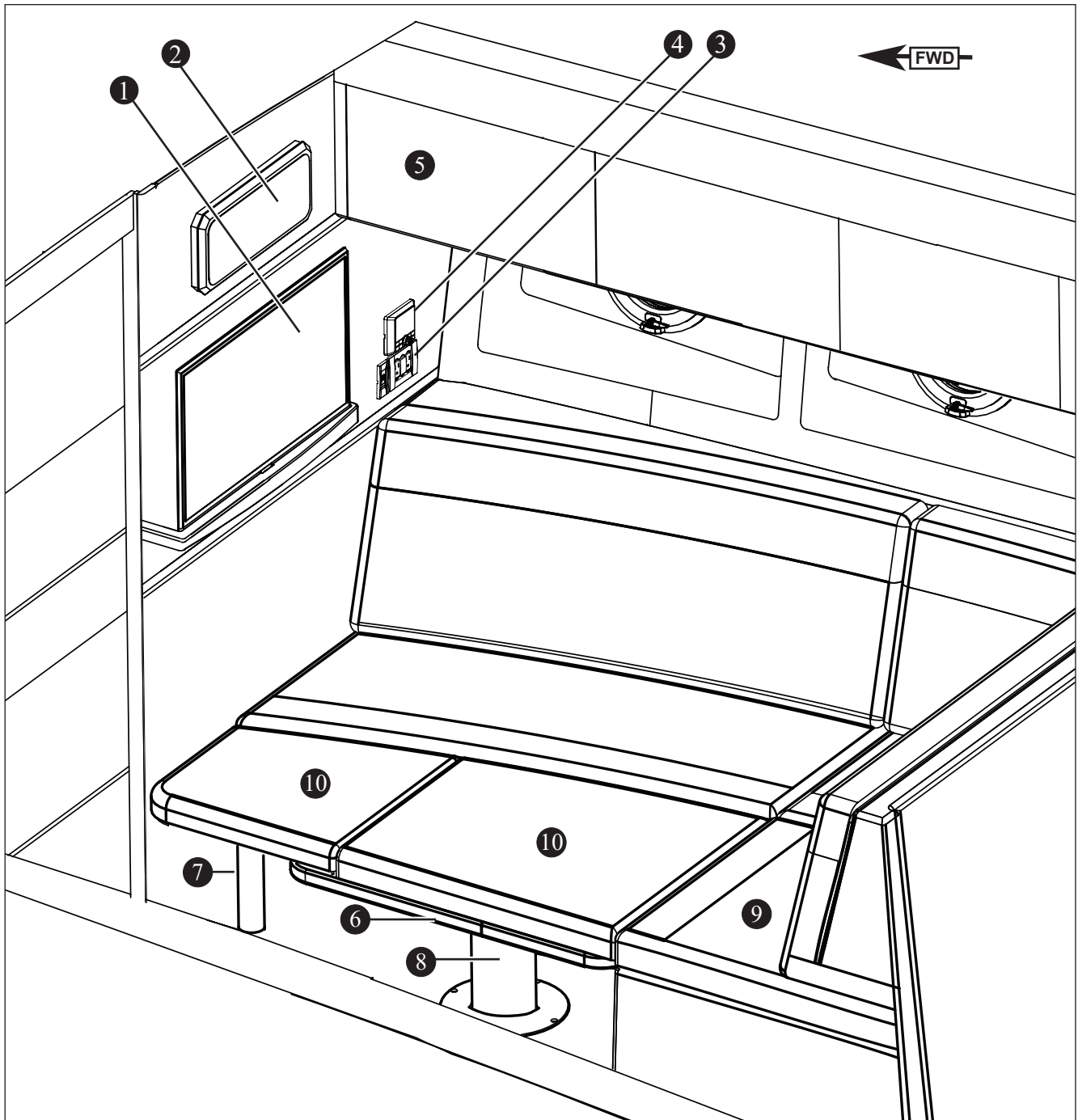

- | | |
|--|-------------------------------|
| 1 TV | 6 SALON TABLE |
| 2 SPEAKER | 7 SUPPORT POST |
| 3 GROUNDED OUTLETS | 8 PEDESTAL |
| 4 STEREO | 9 FREEZER (OPTION) UNDER SEAT |
| 5 SATELLITE RECEIVER (OPTION) IN CABINET | 10 REMOVABLE CUSHION |

Cabin Panels and Displays

Figure 2.27.1

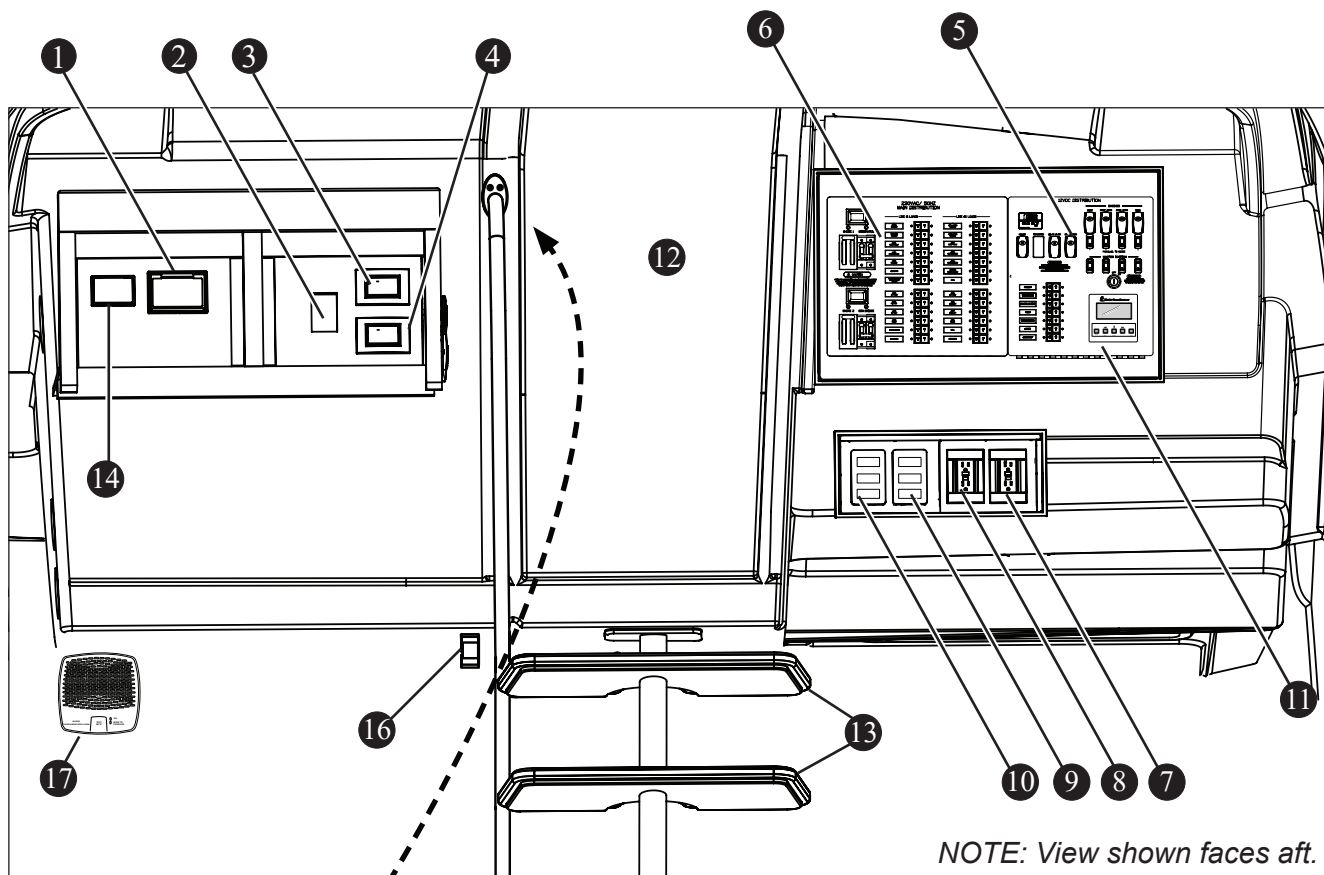

NOTE: View shown faces aft.

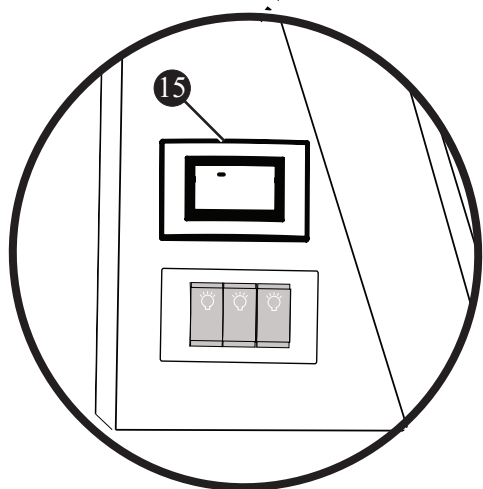

- 1 GYROSCOPIC STABILIZER PANEL (OPTION)
- 2 TV GAIN / A-B SWITCH
- 3 PORT DECK A/C DISPLAY
- 4 STARBOARD DECK A/C DISPLAY
- 5 DC DISTRIBUTION PANEL
- 6 AC DISTRIBUTION PANEL
- 7 CABIN GFCI OUTLET
- 8 DECK GFCI OUTLET
- 9 240V DECK STOVE GFCI RESET (OPTION)
- 10 240V GRILL GFCI RESET
- 11 GENERATOR DISPLAY/CONTROLS
- 12 DOORWAY TO DECK
- 13 STEPS UP TO DECK
- 14 CHILLER SYSTEM DISPLAY (OPTION)
- 15 A/C DISPLAY (CABIN)
- 16 SALON TABLE SWITCH
- 17 CARBON MONOXIDE DETECTOR

NOTE: Mid-berth area below steps not shown.

Stateroom
Figure 2.28.1

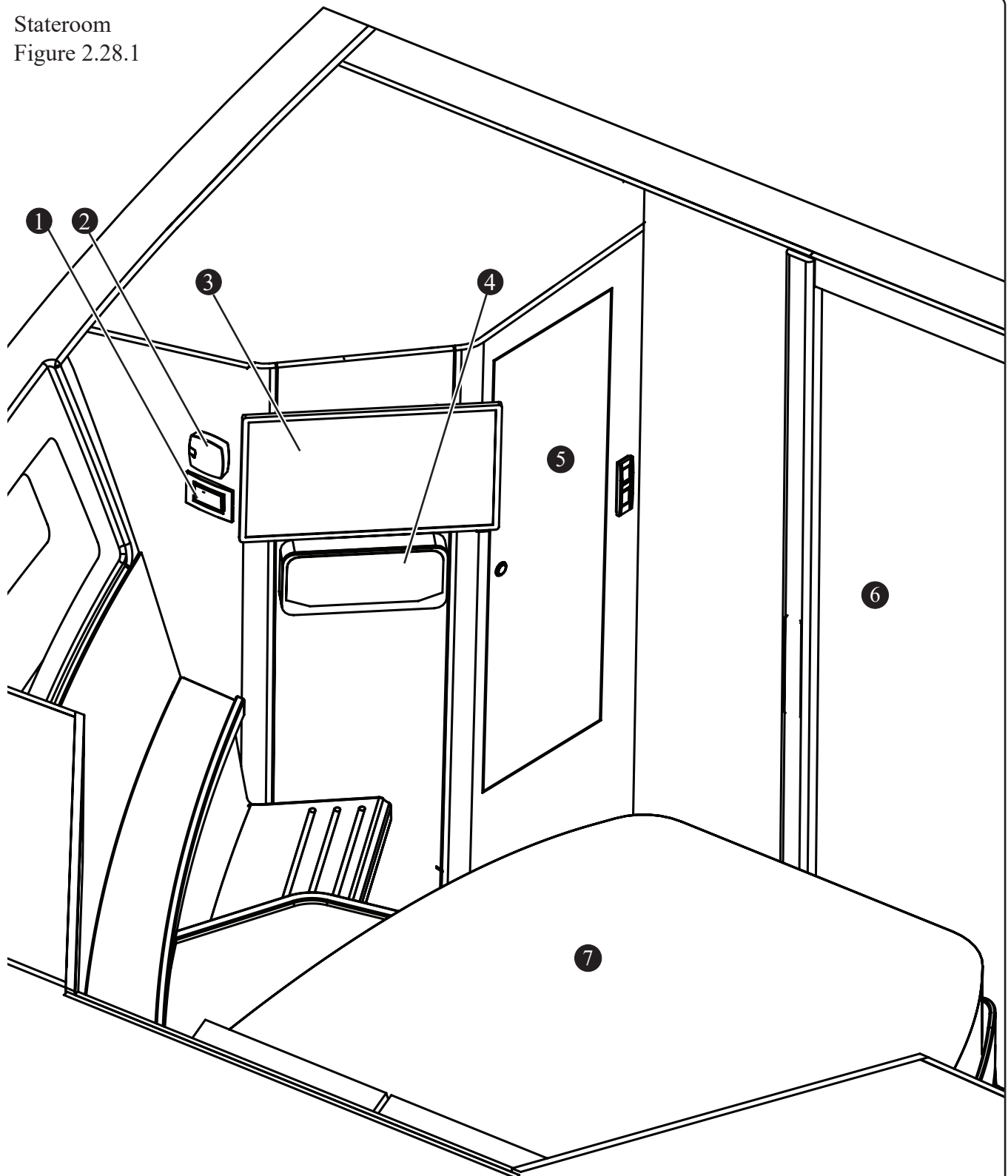

- 1 A/C CONTROL PANEL (STATEROOM)
- 2 CARBON MONOXIDE DETECTOR
- 3 TV
- 4 SPEAKER

- 5 CLOSET¹
- 6 STATEROOM DOOR (TO SALON)
- 7 BED WITH STORAGE COMPARTMENT²

¹NOTE: Satellite receiver (option) behind inner closet panel

²NOTE: Vacuum stored inside compartment under bed

Head Controls
Figure 2.29.1

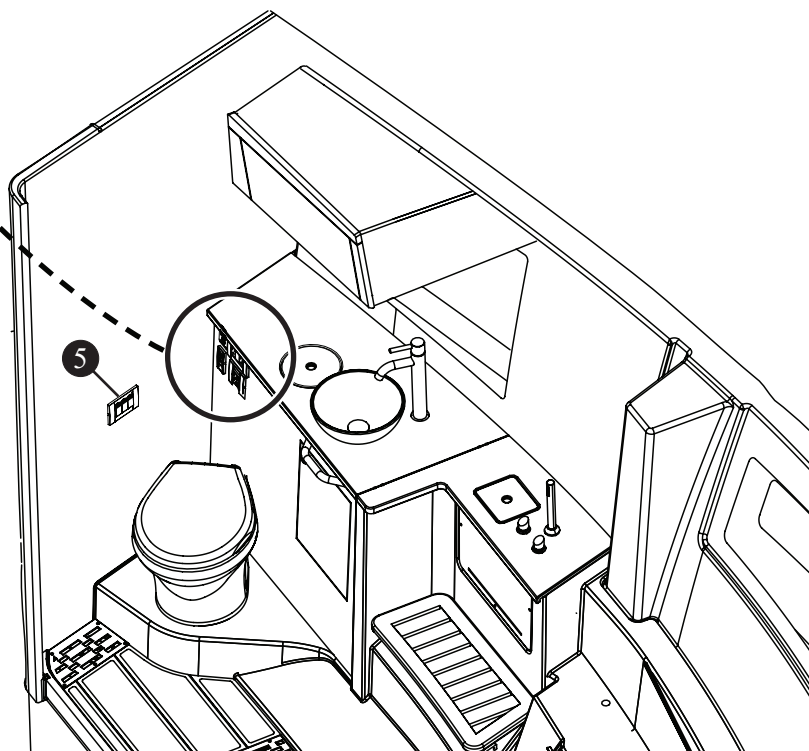
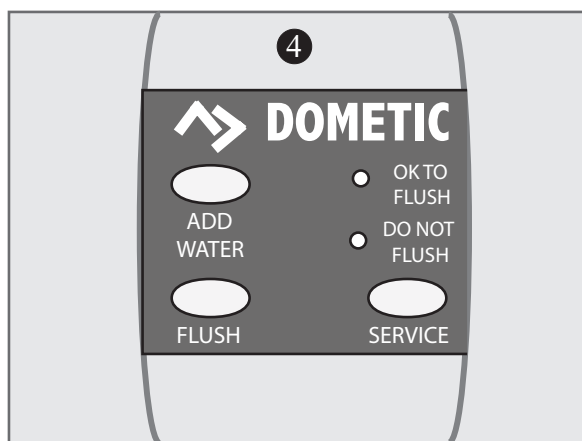
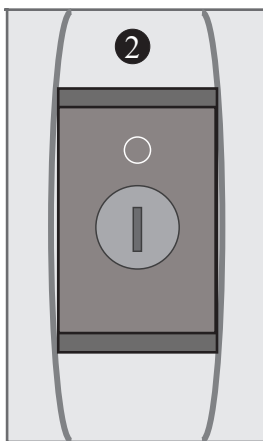
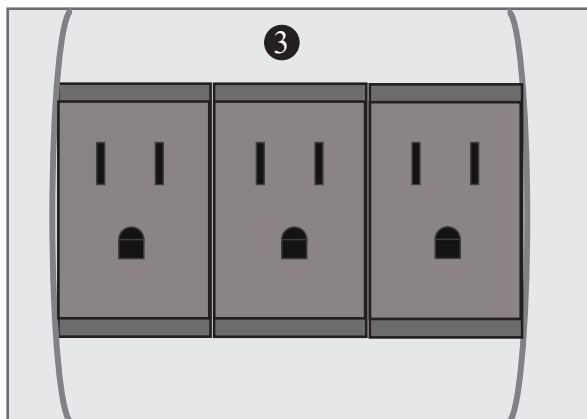
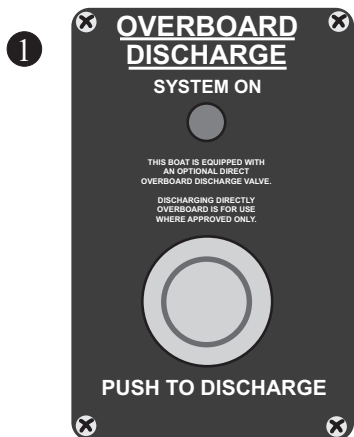

- 1 OVERBOARD DISCHARGE SWITCH
- 2 OVERBOARD DISCHARGE LOCK
- 3 GROUNDED OUTLET
- 4 HEAD SWITCHES
- 5 LIGHT AND FAN SWITCHES

Canvas
Figure 2.30.1

▲ DANGER

Exhaust fumes from engines contain deadly carbon monoxide (CO). Boats enclosed with canvas or with poor ventilation are most likely to collect fumes. CO sickness symptoms include headache, nausea and dizziness. Do not mistake these symptoms for sea sickness. Even in rainy and/or cold weather, fresh air must circulate through the boat to avoid CO poisoning.

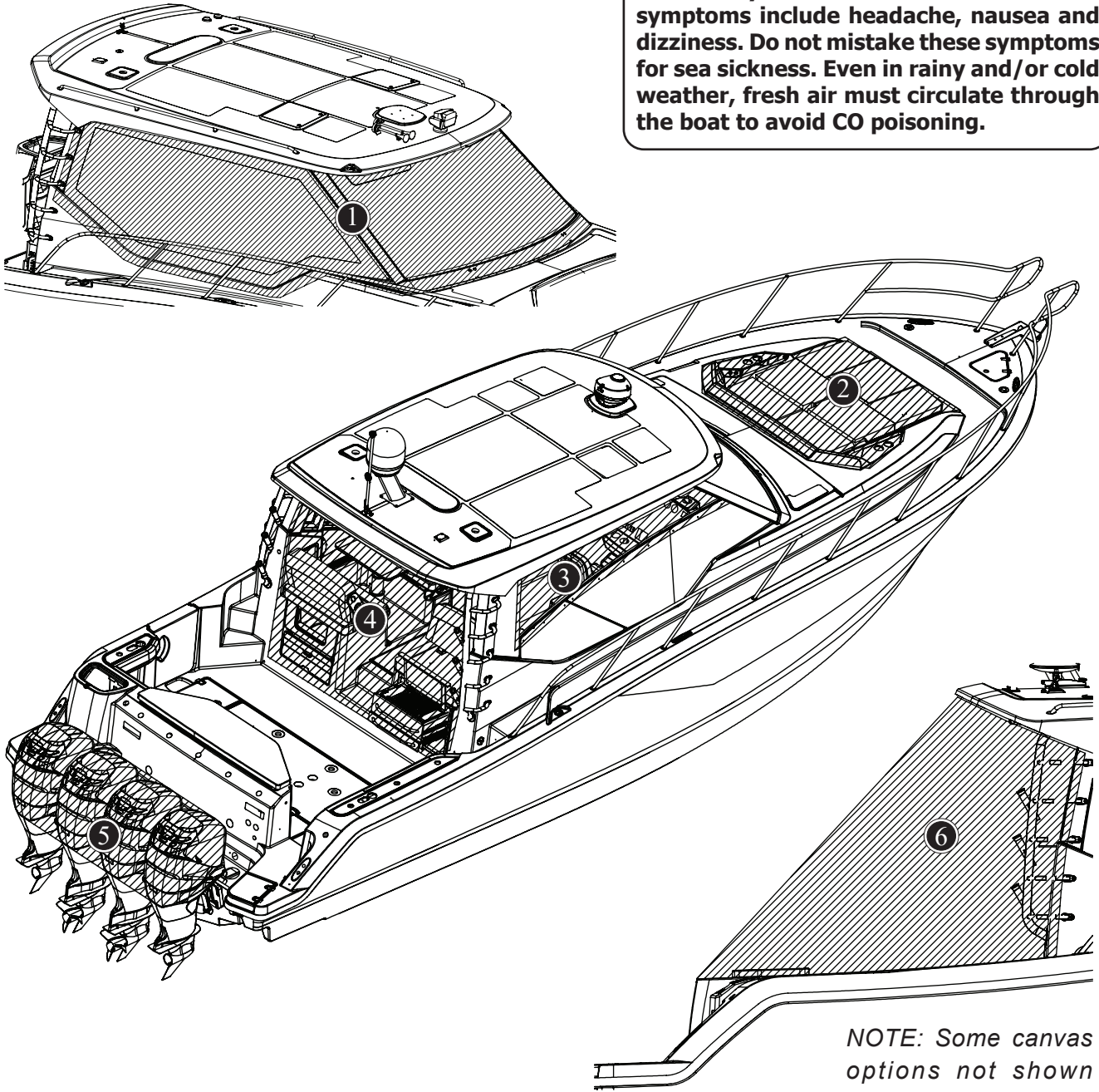

NOTE: Some canvas options not shown including seating, prep station, and helm.

- 1 WINDSHIELD COVER (OPTION)
- 2 BOW LOUNGE COVER
- 3 SIDE CURTAIN (2)

- 4 DROP CURTAIN
- 5 ENGINE COVER (OPTION)
- 6 MOORING COVER (OPTION)

Pilothouse (option)

⚠ CAUTION

Windows and doors must remain closed and latched while underway or injury may occur. To operate window switches, first open door and then unlatch windows.

The pilothouse enclosure is a climate-controlled helm environment (see Figure 2.31.1). Improve airflow by opening windshield vents, hardtop hatches, skylight (option), or powered windows. If powered windows are left open while underway, an audible alarm sounds and a message appears on the helm display to close windows. If dangerous carbon monoxide (CO) levels are detected in the pilothouse, an audible CO detector alarm sounds. See chapter 1, *Safety*, for more information on carbon monoxide (CO) dangers.

⚠ DANGER

Never ignore an alarm.

Pilothouse (Option)
Figure 2.31.1

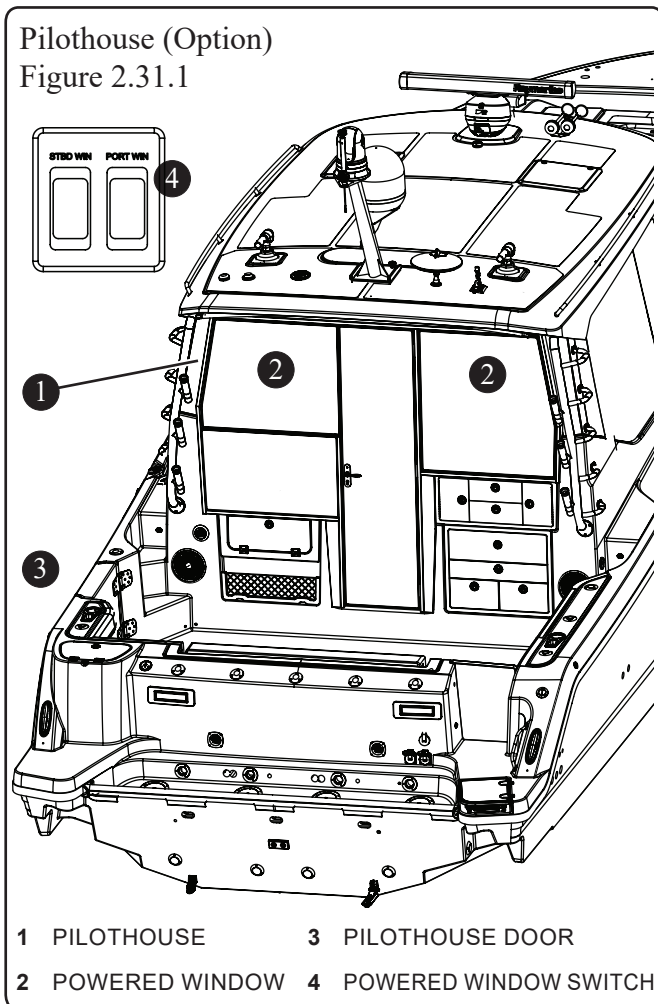

Diesel Heater (option)

The pilothouse diesel heater provides heat to the enclosed pilothouse. The heater control is mounted behind the helm seat, while the heater unit, control module, and portable fuel tank are located inside the heater compartment (see Figure 2.31.2).

Diesel Heater (option)
Figure 2.31.2

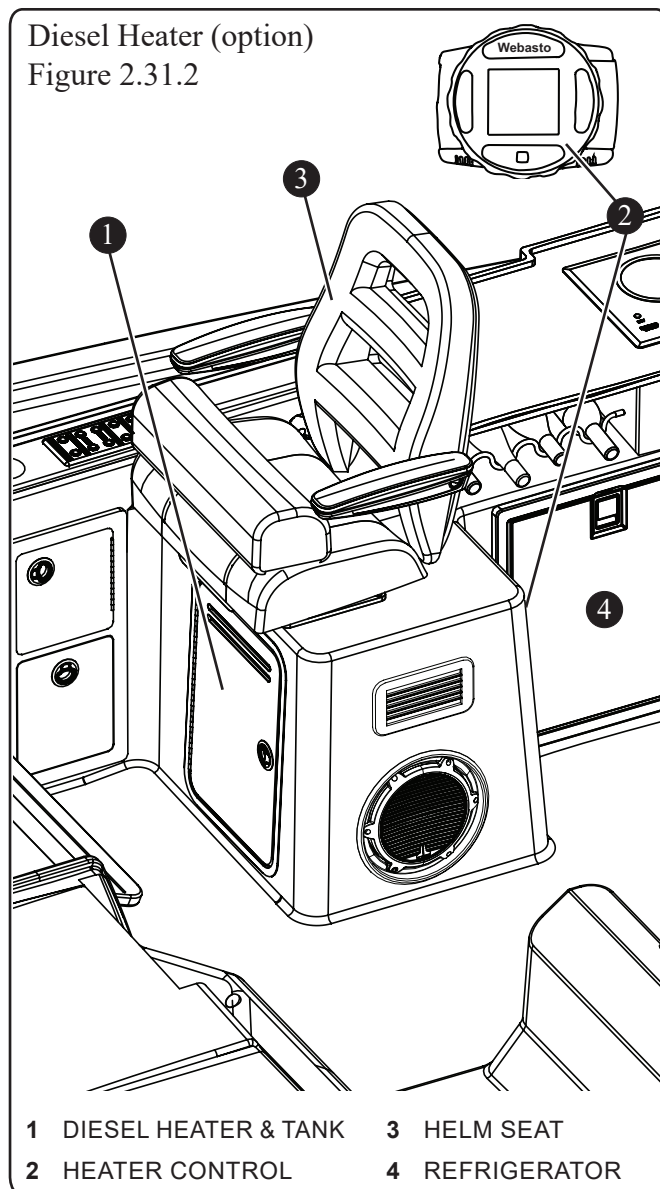

To remove portable diesel fuel tank for refill:

1. Loosen and remove tank's ground cable.
2. Use quick disconnect to remove fuel line.
3. Unclasp tank strap.
4. Remove tank from tray.

Upper Station Helm (Option)
Figure 2.32.1

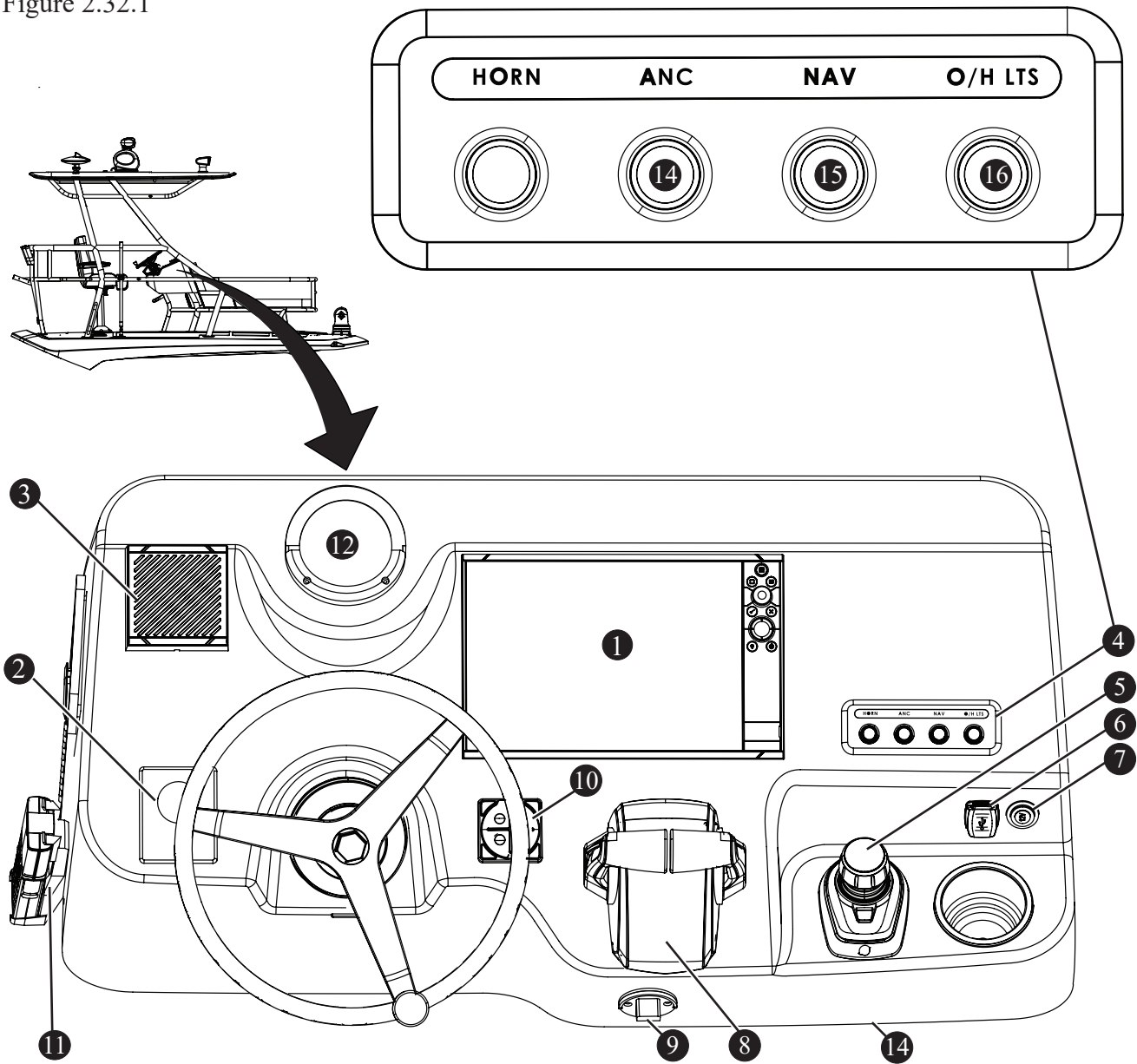

- | | |
|------------------------------|-----------------------------------|
| 1 HELM DISPLAY | 9 ENGINE EMERGENCY STOP SWITCH |
| 2 SPOTLIGHT CONTROL | 10 TRIM TAB SWITCHES |
| 3 VHF RADIO SPEAKER | 11 VHF RADIO HANDSET |
| 4 SWITCH PANEL | 12 COMPASS |
| 5 JOYSTICK PILOTING | 13 FUSE BLOCK (IN DROP-DOWN DOOR) |
| 6 USB CHARGER | 14 ANCHOR LIGHTS |
| 7 12V CHARGER | 15 NAVIGATION LIGHTS |
| 8 THROTTLE AND SHIFT CONTROL | 16 OVERHEAD LIGHTS |

Bilge Pumps

This vessel is equipped with multiple automatic bilge pumps and one high water emergency pump (see Figure 3.1.1 and Figure 3.2.1). Each pump is activated when water reaches a predetermined level and then discharged overboard by way of a thru-hull fitting. The aft pump and high water pump can be accessed through the aft mechanical access hatch. The remaining pumps can be accessed via the forward bilge under the cabin steps.

Aft Bilge
Figure 3.1.1

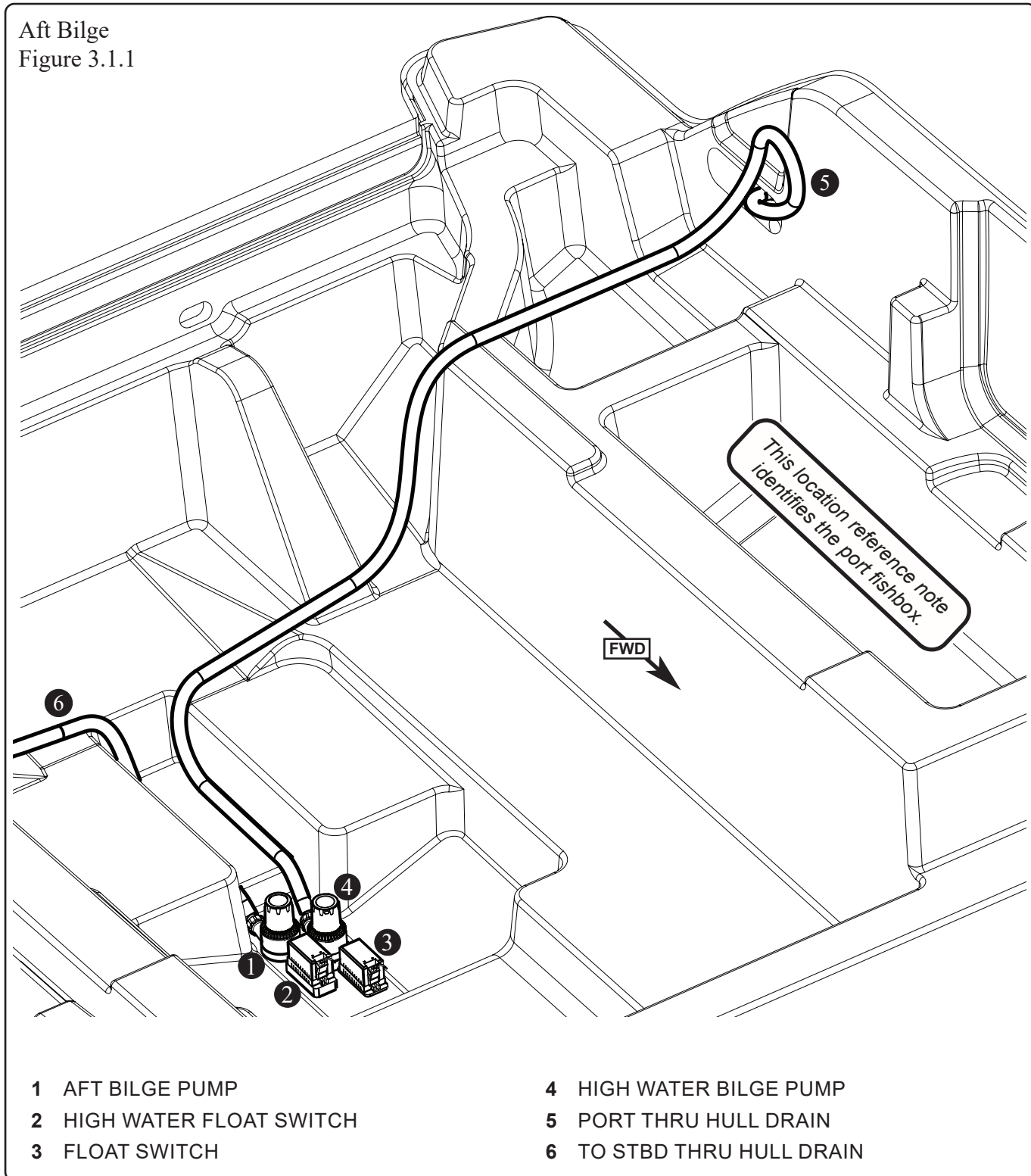

Forward Bilge
Figure 3.2.1

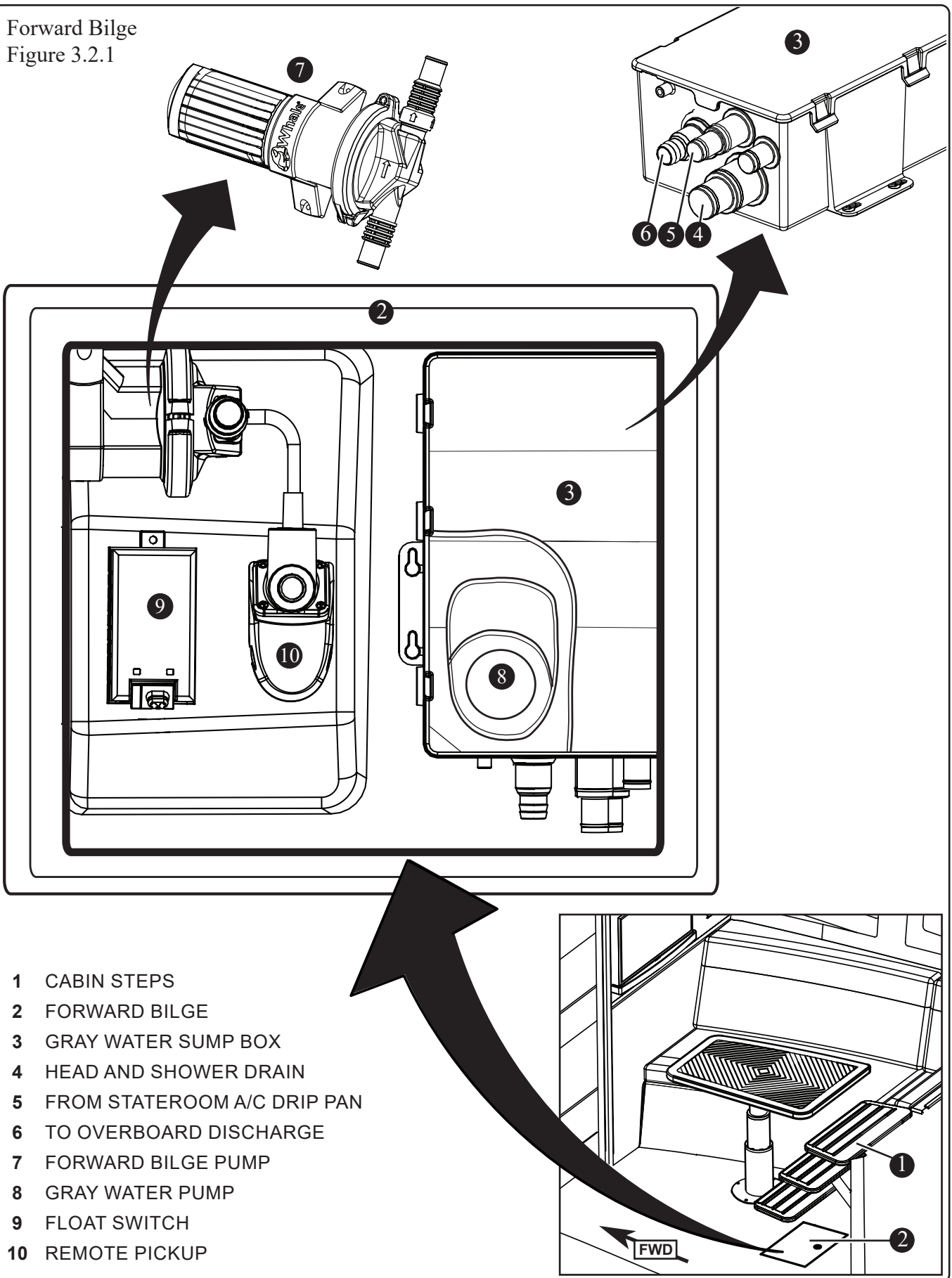

Forward Bilge

This vessel is equipped with a gray water sump box located in the forward bilge under the cabin steps (see Figure 3.2.1). Gray water from the shower and stateroom A/C drip pan collect in the gray water sump. The sump houses its own automatic pump. When enough water has accumulated to raise the float switch in the sump, the sump starts and water is discharged out through the hull. Periodically remove the gray water sump cover and check to ensure the pump and float switch are in proper working order. Clean out any obstructions that inhibit the pump from operating correctly.

Also in this location are the forward bilge pump, float switch, and bilge's remote pickup (see Figure 3.2.1). The pump starts automatically if high water is detected. Clean out any obstructions that inhibit the pump from operating correctly.

REFER TO THE OWNER'S PACKET FOR COMPLETE INSTRUCTIONS AND WARRANTY INFORMATION.

Bilge Pump Maintenance

Frequently inspect the area under all float switches to ensure they are free from debris and bilge oil. Inspect bilge pump water intakes (see Figure 3.3.1) and keep them free of dirt or material which may impede the flow of water.

REFER TO THE OWNER'S PACKET FOR COMPLETE INSTRUCTIONS AND WARRANTY INFORMATION.

High Water Bilge Pump

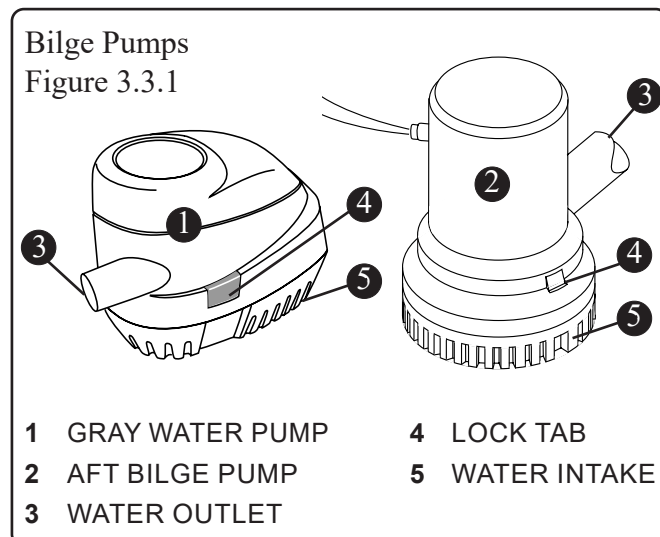

If the high water float switch is activated, an audible alarm sounds at the helm and the emergency high water bilge pump automatically begins pumping. If this occurs, immediately:

1. Switch all bilge pumps on.
2. Use radio to broadcast a *PAN-PAN* distress call (see chapter 1, *Safety*).
3. Turn off all AC and DC breakers before stepping into the water in the bilge.
4. Identify the problem and take necessary action to stop the inflow of water.

If your situation no longer requires assistance, you must cancel the distress call.

Bilge Discharge; Fuel and Oil Spills

Regulations prohibit discharging fuel or oily waste in navigable waters. Discharge is defined as any action which causes a film, sheen or discoloration on the water surface, or causes a sludge or emulsion beneath the water surface. A common violation is bilge discharge. Violators are subject to severe penalties and may also be responsible for the cost of cleanup which could be substantial. Use rags or sponges to soak up fuel or oily waste, then dispose of properly ashore. If a large quantity of fuel or oil is in the bilge, contact your dealer to remove it. Never pump contaminated bilge discharge overboard.

NOTICE

Bilge pumps are wired directly to battery, therefore the float switch remain clear of debris to prevent continuous operation and subsequent battery discharge. Inspect bilge pump intakes frequently and keep free of dirt or material which may impede water flow through pump. After using shower, run clean water through shower drain to flush out soap residue.

Fuel System

NOTICE

Read and understand engine manufacturer's manual in owner's packet for complete fuel and fueling information and warnings.

CAUTION

Fuel spills can be dangerous and can subject offenders to severe penalties. Leaking fuel is a fire and explosion hazard; inspect fuel tanks and exposed lines for leaks and corrosion. Improper fuel use can damage engine and void warranty. Follow engine manufacturer's recommendations regarding fuel/oil use.

The fuel system (see Figure 3.4.1) is designed to meet EPA regulations using certified components to limit fuel vapor emissions. This boat's fuel system provides the following benefits:

- Automotive style refueling, automatic nozzle shut-off, and fuel nozzle retention. This system sends a signal to shut off before spit-back or well-back through the fill opening occurs.
- Overfill protection reduces the possibility of accidental fuel spills.
- Reduce hydrocarbon emissions through the use of a specially-designed fuel fill. This fuel fill has a permanently attached cap that provides an audible click when sealed properly.

Fuel System

Figure 3.4.1

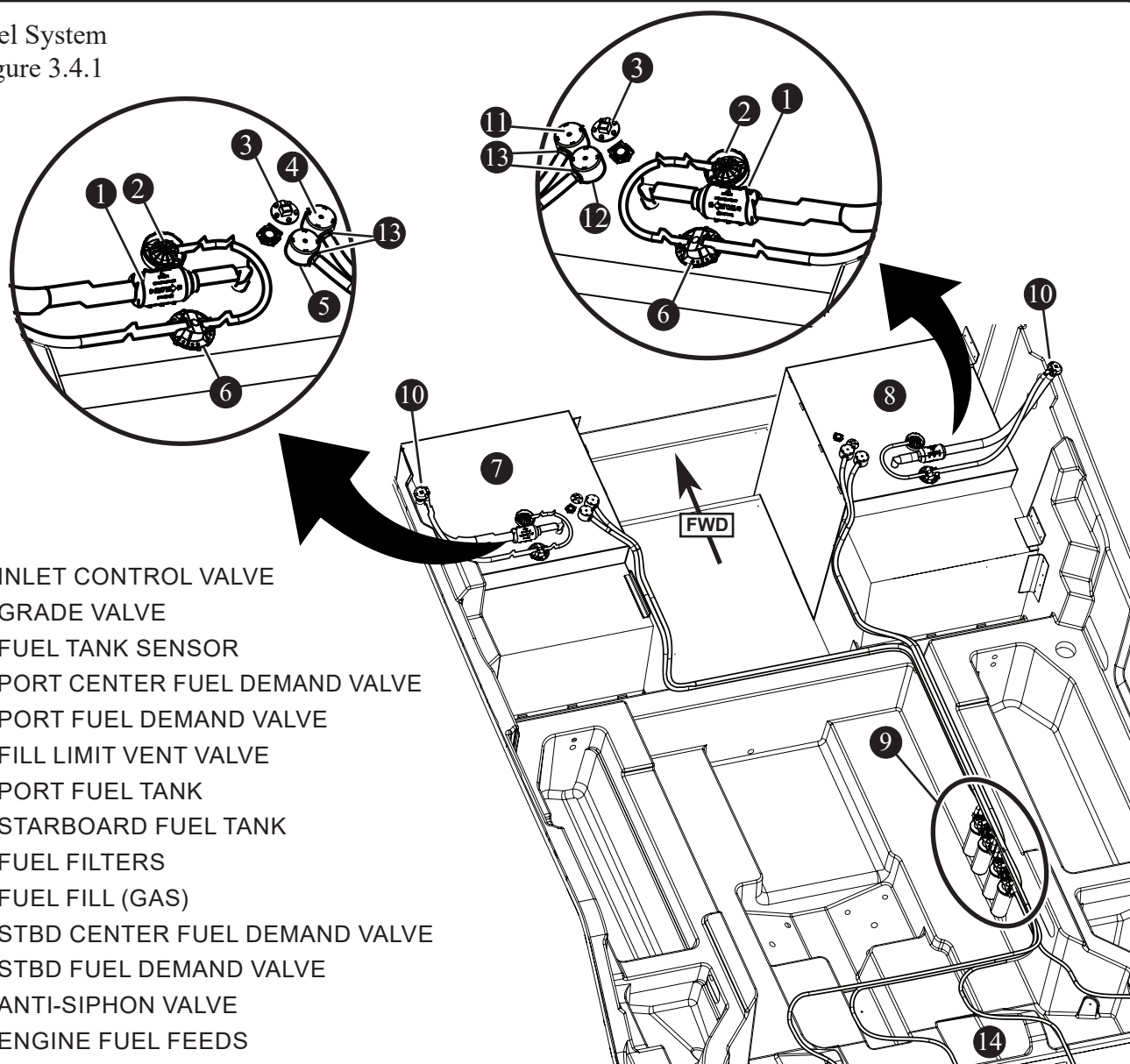

- 1 INLET CONTROL VALVE
- 2 GRADE VALVE
- 3 FUEL TANK SENSOR
- 4 PORT CENTER FUEL DEMAND VALVE
- 5 PORT FUEL DEMAND VALVE
- 6 FILL LIMIT VENT VALVE
- 7 PORT FUEL TANK
- 8 STARBOARD FUEL TANK
- 9 FUEL FILTERS
- 10 FUEL FILL (GAS)
- 11 STBD CENTER FUEL DEMAND VALVE
- 12 STBD FUEL DEMAND VALVE
- 13 ANTI-SIPHON VALVE
- 14 ENGINE FUEL FEEDS

Fuel Tank

NOTICE

Fuel gauge only reads accurately when boat is level (not underway).

The two low-permeation aluminum fuel tanks (see Figure 3.4.1) each have a usable fuel capacity of 310 gallons (1173 liters). The non-usable portion of the tank is fuel that is below the pickup tube and the ullage area that has been incorporated. Fuel tanks with levels less than 1/4 full can cause engine stalling problems due to fuel starvation or by allowing sediment to enter fuel lines. Keep tank full and monitor fuel level often.

REFER TO THE OWNER'S PACKET FOR COMPLETE INSTRUCTIONS AND WARRANTY INFORMATION.

Fuel Vent

The fuel tank vent is integrated into the fuel fill deck fitting. The VaporTec fuel pressure management system (fuel fill deck fitting, integrated check valve, fill limit vent valve, and grade valve) ensures that the fuel system maintains proper vapor pressure, which, if unchecked, can seriously damage a boat or engine. The vent serves as an over pressure/vacuum release with anti-surge and flame/spark arresting protection. The tank's grade valves allow proper ventilation for storage, trailering on an incline without fuel seepage.

Fuel Distribution System

Fuel is delivered to the engines through the fuel valves, anti-siphon valves (ASV) and the fuel lines. The fuel valves prevent built up tank pressure from being transferred to the engines while still allowing fuel to flow. The anti-siphon valve is a safety feature designed to prevent fuel from siphoning out of the tank if the fuel line were to be cut or broken below the level of the fuel in the tank. In this case, some fuel would leak from the line, but would not allow the entire contents of the tank to siphon out.

Filling the Tank

The fuel system is designed to automatically shut off the fuel nozzle when the tank is full, similar to an automotive fuel system. The tank is filled when the fuel fill nozzle has shut itself off the second time. The SecureStop automatic fuel shut off system (fuel fill deck fitting, integrated check valve, fill limit vent valve), ensures a clean a trouble-free fill-up. Attempting to fill the tank past this point may cause some components to malfunction.

! WARNING

The fuel system on this vessel complies with all applicable ABYC standards. Fueling station pump flow rates that exceed 18 gallons (68 liters) per minute may damage system components and cause fuel leakage into vessel.

! WARNING

Use of a portable fuel container to fill fuel tank can result in overfilling and circumvent the safety features designed into fuel tank.

Modification of any fuel system components or replacement of these components with unauthorized parts may result in over-pressurization of fuel system and circumvent safety features designed into tank.

NOTICE

Record this vessel's fuel capacity and consumption. Drastic changes in consumption and mileage may indicate a problem.

Static Electricity

▲ DANGER

Static electricity can ignite gasoline vapors causing serious injury, death and/or destruction of property. Check for leaks in tubing, connections and hoses. Avoid all forms of ignition when fuel fumes are noticed. Correct cause of leaks and ventilate area to insure that no fumes remain prior to energizing any equipment, smoking and/or starting engines.

Static electricity can ignite gasoline vapors that have not been ventilated outside an enclosed area. Use extreme caution when fueling this vessel from

a source other than marinas and gas stations. This vessel's bonding system protects it from creating and discharging static electricity. This vessel must be in contact with the water or a land-based grounding system. The following suggestions will help keep you safe from static electricity while refueling.

- Never fuel boat in unsafe conditions such as suspended on a sling or in a situation that increases the likelihood of static discharge.
- Never use homemade containers to fill tanks.
- Fuel carried on-board outside of a fixed fuel system should be stored in an approved container or in a portable tank such as provided for outboard engines and be stowed safely outside of the engine or living compartment(s).
- Shut down the engines, motors and fans prior to taking on fuel. Any ignition sources should be extinguished before filling the fuel tank.
- Close all ports, windows, doors and hatches.
- Fueling should never be done at night except in well-lit areas.
- Always keep fuel nozzle in contact with edge of the fuel tank opening when filling.
- Ventilate areas where gasoline vapors could collect before starting the engine.
- Wipe up any spillage completely and dispose of rags or waste on shore.
- Secure the fill cap tightly.
- Portable tanks should only be filled while on shore, never on board the boat.

Ethanol-blended Fuel

CAUTION

The use of fuels containing ethanol higher than 10 percent (E-10) can damage your engine and/or fuel system and will void the warranty.

NOTICE

The use of improper gasoline or additives can damage your fuel system and is considered misuse of the system. Damaged caused by improper gasoline or additives is not covered under warranty.

Ethanol has a high octane rating and therefore may be useful in increasing the octane level of unleaded gasoline. The fuel-system components of Mercury engines have been tested to perform with a maximum of 10 percent ethanol-blended gasoline.

Special precautions should be considered with the use of fuel containing ethanol in your system. Fuels with ethanol can attack some fuel-system components, such as tanks and lines, if they are not constructed from ethanol-compatible materials. This can lead to operational problems or safety issues such as clogged filters, leaks or engine damage.

This vessel was manufactured and shipped from the factory with ethanol-compatible materials. Before introducing gasoline with ethanol into your fuel tank, ask your dealer if any components have been added or replaced that are not recommended by Boston Whaler, Mercury, or may not be ethanol-compatible.

It is best to maintain a full tank of fuel when the vessel is not in use. This will reduce air flow in and out of the tank due to changes in temperature as well as limiting ethanol exposure to humidity and condensation in the tank.

Phase Separation

Humidity and condensation create water in your fuel tank which can adversely effect the ethanol blended fuel. A condition called phase separation can occur if water is drawn into the fuel beyond the saturation point. The presence of water in the fuel beyond the saturation level will cause most of the ethanol in the fuel to separate from the bulk fuel and drop to the bottom of the tank, significantly reducing the level of ethanol in the fuel mixture in the upper level (phase). If the lower level (phase), consisting of water and ethanol, is deep enough to reach the fuel inlet, it could be pumped directly to the engine(s) and cause significant problems. Engine problems can also result from the reduced ethanol/fuel mixture left in the upper phase of the tank. There is no practical additive that can prevent or correct phase separation. The only solution is to keep water from accumulating in the tank. If phase separation does occur, your only remedy is to drain the fuel, clean and dry the tank completely and refill with a fresh, dry load of fuel.

Fuel/Water Separators

Fuel/water separators (filters) are provided for both engines and the generator. The addition of another in-line filter to the system may create a possible flow restriction that can starve the engines of fuel. It is advisable to carry extra on-engine filters in case filter plugging from debris in the fuel tank becomes a problem during boating. Consult your Boston Whaler dealer for recommendations regarding filters that meet Mercury's specifications.

Maintenance

Periodically inspect for the presence of water in the fuel tank. If any is found, all water must be removed and the tank completely dried before refilling the tank with any fuel containing ethanol.

NOTICE

Carry spare filters onboard as contaminated fuel can easily clog a filter.

Fuel and Boat Storage

Long periods of storage and/or non-use, common to boats, create unique problems. When preparing to store a boat for a period of two months or more, it is best to completely remove all fuel from the tank. If not possible, fill tank and add fuel stabilizer per manufacturer's instructions. Maintaining a partially full tank during storage is not recommended because the void above the fuel allows air movement that can introduce water through condensation.

REFER TO THE OWNER'S PACKET FOR COMPLETE INSTRUCTIONS AND WARRANTY INFORMATION.

Theft Deterrent with 1st Mate and Remote Connectivity System (Whaler Watch) (Option)

Whaler Watch is a remote-monitoring system that provides a snapshot of the boat's key components, operating systems, as well as alarm notifications.

Subscribing to Whaler Watch* allows use of the app and Web portal to monitor the following:

- 1st Mate safety and security system – Anti theft feature immobilizes engines.
- GPS tracking system with geofence notifications.
- Remote monitoring and notification of high-water bilge alarm, tank levels, batteries, shore power connections, and propulsion system information.
- Remote control of courtesy and underwater lights.

*A limited subscription to Whaler Watch is included and thereafter the service is subscription based. To access the system remotely visit whalerwatch.net.

For more information, see the owner's packet or contact an authorized Boston Whaler dealer.

Throttle and Shift Control

The throttle and shift control is used to manage both the shifting mechanism and the throttle (see Figure 3.8.1). This control regulates engine RPMs, which controls the speed of the boat. Moving the levers forward shifts the engine into forward gear. Continuing to move the lever forward progressively increases the forward speed of the boat. Moving the lever backwards shifts the engine into reverse gear, and continuing to move the lever back progressively increases the reverse speed of the boat. The levers must be in the neutral position to start the engine(s). When in neutral, otherwise known as the idle position, the propeller is not engaged. A green neutral LED light is illuminated atop the throttle and shift lever when in neutral.

Throttle and Shift Control
Figure 3.8.1

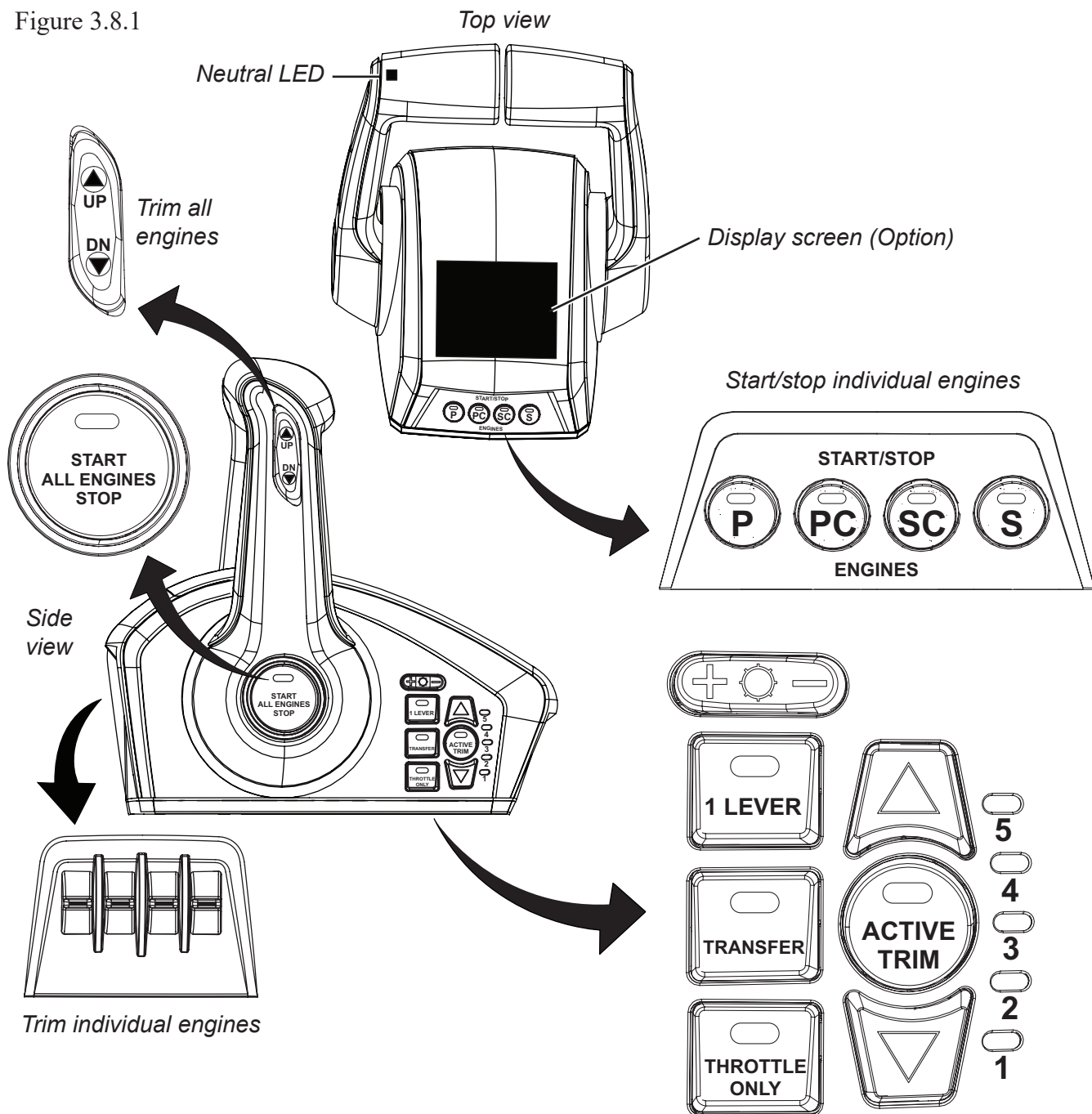

NOTE: When equipped with optional V12 engines, control configuration varies.

Buttons and Switches

Basic button/switch use on the throttle and shift control are detailed below (see Figure 3.8.1).

Neutral LED

Illuminates when engines are in neutral gear position.

Trim All Engines

Raises and lowers all engines.

Start/Stop All Engines

Starts or stops all engines sequentially from port to starboard.

Start/Stop Individual Engines

Starts or stops an individual engine.

Display Screen (Optional)

Shows pop-ups for advanced features as well as system information and faults.

Trim Individual engines

Raises and lowers individual engines.

Brightness

Increases and decreases brightness on control unit.

1 Lever

Enables throttle and shift functions of all engines to be controlled by the port lever.

Transfer

Transfer boat control to a different helm.

Throttle Only

Increase engine RPMs without shifting into gear.

Active Trim

Turns the Active Trim feature on or off.

Profile

Changes the selected Active Trim profile.

REFER TO ENGINE MANUFACTURER'S MANUAL IN OWNER'S PACKET FOR COMPLETE INSTRUCTIONS AND WARRANTY INFORMATION.

Starting the Engines

Pre-start Checklist

1. Ensure lower units of engines are in water and engine emergency stop switch is in run position.
2. Insert theft deterrent system key and rotate clockwise; red light illuminates and then green.

Start-up Procedure

1. On helm controls, ensure throttle and shift levers are in the neutral position.
2. On DC distribution panel, turn on *ENGINES* switch for each engine (see Figure 3.10.1).
3. Switch on *MASTER IGNITION* switch for each engine (see Figure 3.10.1).
4. Insert master ignition key and rotate to the *ON* position (see Figure 3.10.1).
5. On control (see Figure 3.8.1), press *START ALL ENGINES* button.
6. Check to ensure throttle and shift lever's neutral indicator light is illuminated (see Figure 3.8.1).

CAUTION

Shift controls into neutral before starting engine. Shift only when engine is at idle. Reversing at high speeds can cause flooding/swamping due to water being pushed over the transom.

NOTICE

Wind and sea currents can change how this vessel responds while in motion. Understanding this vessel and its reactions at speed will make boating safer and more enjoyable.

NOTICE

Ensure continuous visibility of other boats, swimmers and obstacles during bow-up transition to planing. Adjust engine to an intermediate trim as soon as boat is on plane to avoid possible ejection due to boat spinout. Do not attempt to turn boat when the engine is trimmed extremely down, under or in.

Engine(s) Warm Up

The *THROTTLE ONLY* button on the throttle and shift control (see Figure 3.8.1) allows the operator to increase engine RPMs for warm-up without being in gear. To operate:

1. Ensure throttle and shift levers are in neutral.
2. Press and hold *THROTTLE ONLY* button while moving port throttle and shift lever forward.
3. Hold in *THROTTLE ONLY* button until horn sounds twice and neutral lights start flashing. Flashing lights indicate *THROTTLE ONLY* program is engaged.
4. Advance port throttle and shift lever to increase engine RPMs; RPMs are limited to prevent engine damage.
5. To disengage *THROTTLE ONLY*, return port throttle and shift lever back to neutral position.

Stopping the Engines

1. Ensure throttle and shift levers are in neutral (see Figure 3.8.1).
2. Press *START ALL ENGINES* button.
3. Turn the master ignition key switch off.
4. Switch off the battery for each engine battery.

Bow Thruster (Option)

NOTICE

Bow thruster is not included when joystick piloting option is selected.

Bow Thruster Location
Figure 3.11.1

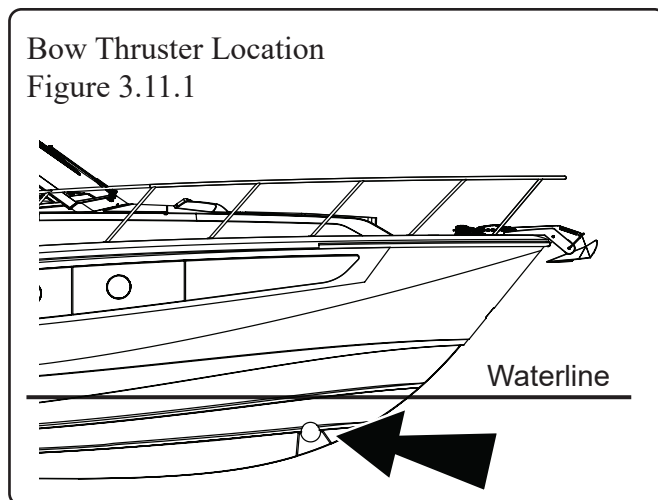

This vessel is equipped with a 24V bow thruster (see Figure 3.11.1 and Figure 3.11.2), giving the operator additional bow control when docking or maneuvering in tight spaces. The bow thruster motor, house batteries, battery charger, and fuse block can be accessed via the storage hatch under the stateroom bed.

Use the bow thruster joystick to operate and maneuver the bow of this vessel. To operate:

1. Depress *THRUSTER* switch located on the DC distribution panel in the cabin.

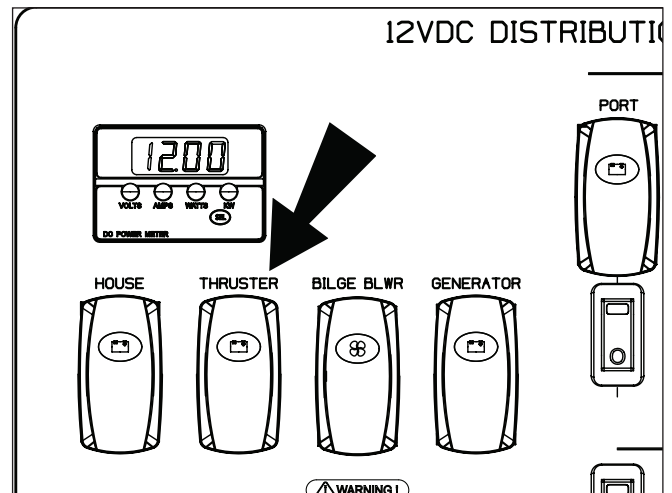

Bow Thruster Joystick
Figure 3.11.2

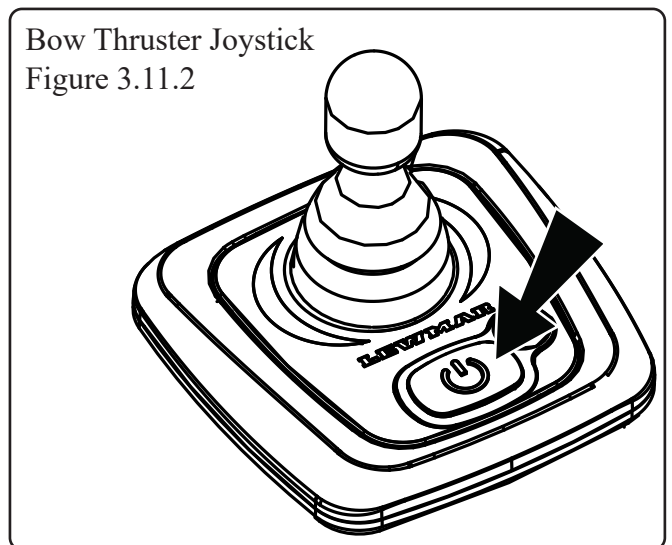

2. Press power button on bow thruster joystick; hold one second.
3. Lift joystick and move it in the desired direction to move the bow (see Figure 3.12.1). When desired boat movement has been achieved return the joystick to the center position (spring return).

NOTICE

If thruster is operated constantly for three minutes it powers down and panel deactivates. The system is designed to automatically power down after 20 minutes of no operation. If thermal cut-out is activated, all power to the controls is disabled. Wait for unit to cool down.

Bow Thruster Movement
Figure 3.12.1

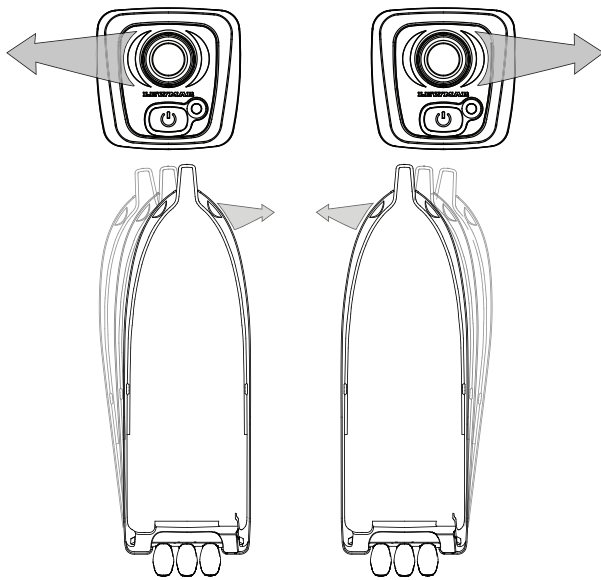

! WARNING

Thoroughly understand bow thruster operation and safety requirements before using. Do not operate in close proximity to swimmers, as a powerful suction is created when in use.

REFER TO OWNER'S PACKET FOR COMPLETE INSTRUCTIONS AND WARRANTY INFORMATION.

! DANGER

Do not operate thruster out of water. It is dangerous to run thruster out of water, even for a few seconds as the motor will overspeed by 300 percent, causing damage to unit and the propeller will cause serious damage or injury to whom or whatever comes in contact with it. In addition, this action will void the warranty.

Joystick Piloting

If equipped, joystick piloting technology provides effortless maneuverability and replaces the traditional bow thruster set up. Joystick piloting takes the stress out of docking, maneuvering in tight spaces and operating in less-than-ideal

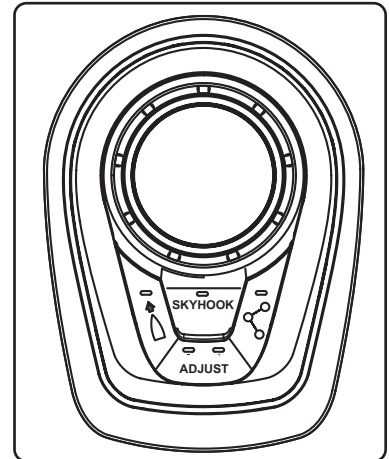

environments by providing the operator 360 degree movement at their fingertips. It also allows the operator to effortlessly move a multi-engine boat in any direction - including sideways, diagonally or spinning on its own axis - with a simple push or twist of a joystick. The operator controls the throttle, shifting and steering with one hand, with the joystick working in conjunction with the independently steered engines to move the boat in the desired direction. If equipped, the joystick is located at the helm (see Figure 3.13.1).

REFER TO OWNER'S PACKET FOR COMPLETE INSTRUCTIONS AND WARRANTY INFORMATION.

Skyhook® (Digital Anchor)

Skyhook pinpoints the boat's position using a GPS satellite antenna and the engines and drives move independently to maintain the position and heading. It's ideal for holding a boat over a fishing spot, waiting for a drawbridge to open or maintaining position waiting to refuel at a marina.

Joystick
Figure 3.13.1

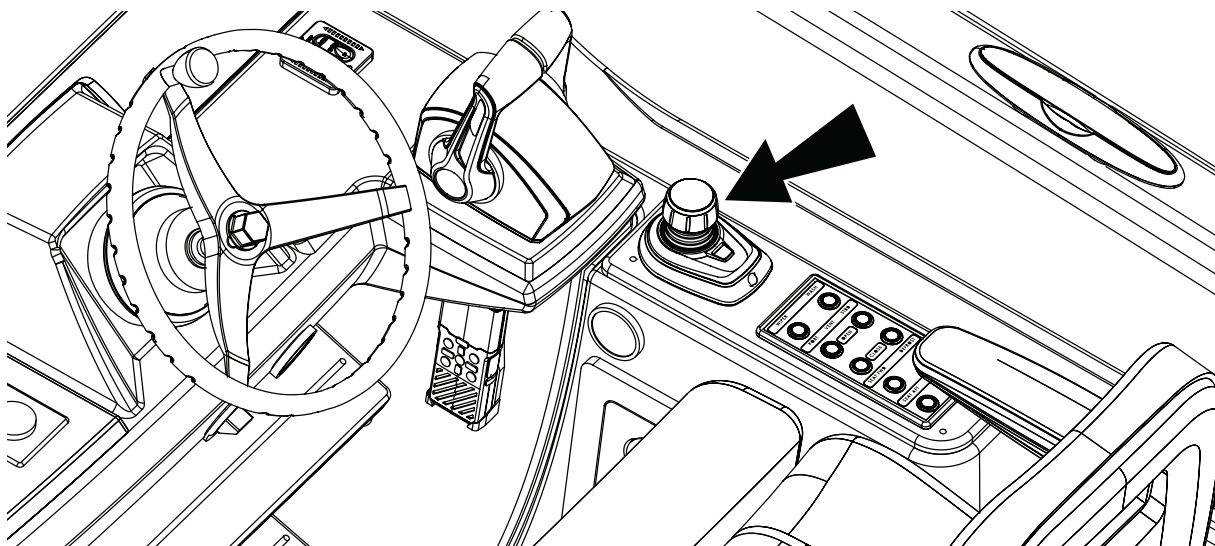

Transfer Joystick Control

! WARNING

Avoid serious injury or death from loss of boat control. Boat operator should never leave the active station while the engines are in gear. Helm transfer should only be attempted while both stations are manned. One person helm transfer should only be attempted while engines are in neutral.

The companion joystick (see Figure 3.13.2), included with helm joystick option, is used for port-side maneuvers. The e-stop switch disengages the joystick.

Helm to Companion Station Transfer

1. Starting at helm joystick station (see Figure 3.13.1), place throttle in neutral position.
2. At companion joystick station (see Figure 3.13.2), press and release *TRANSFER* button; an audible beep is heard and joystick light flashes.
3. Press and release the *TRANSFER* button a second time. An audible beep is heard acknowledging transfer is complete. Station transfer is cancelled if not completed within 10 seconds.

Transfer Companion Station to Helm

The steps for transfer of control from the companion station back to the helm are the same as helm to companion station transfer.

Companion Joystick
Figure 3.13.2

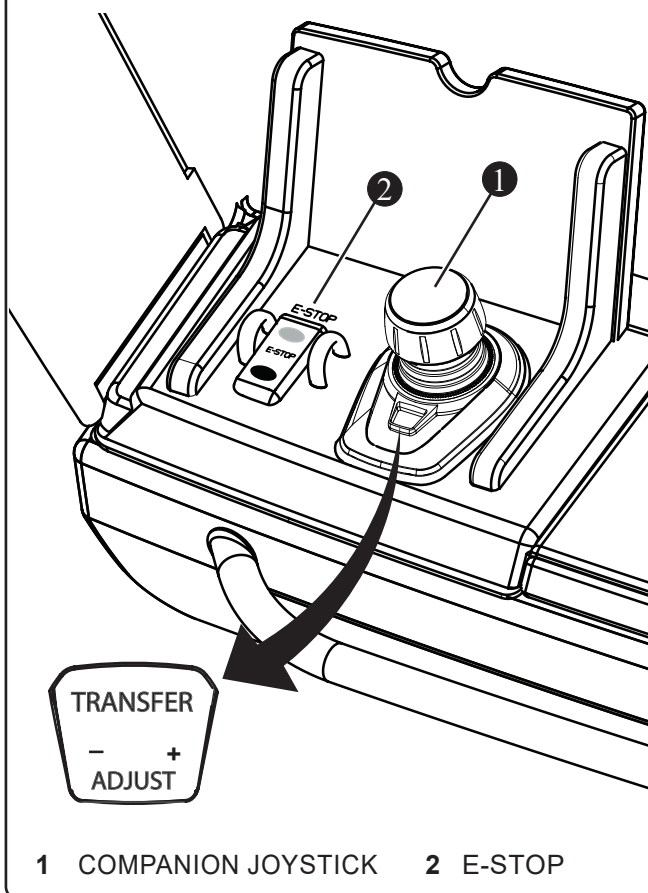

VesselView®

This vessel is equipped with the VesselView software. The software allows the operator to receive critical operational information, displayed clearly and instantly at the helm display. The system continuously monitors and reports information ranging from basic operating data to detailed vessel environmental information.

System Calibration

Boston Whaler or your dealer has calibrated VesselView to the boat's equipment. If equipment is added, the system must be recalibrated.

FOR RECALIBRATION OR MANUFACTURER INFORMATION, REFER TO OWNER'S PACKET. FOR COMPLETE INSTRUCTIONS AND WARRANTY INFORMATION.

VesselView Mobile (Option)

If equipped, VesselView Mobile connects the data network to your iPhone or android mobile device. With VesselView Mobile you can connect on your mobile device with all the digital data your engine supports plus new features such as maintenance reminders, mapping, performance summary, and fault code diagnostics.

Trim Tabs

This vessel's trim tabs (see Figure 3.14.1), located on the bottom of the hull at the transom, are used to assist in leveling the boat caused by uneven weight distribution or strong cross winds. The use of trim tabs may also increase your operator visibility, particularly during initial acceleration. An untrimmed boat reduces fuel economy and increases wear on the engine.

NOTICE

Boats can be operated in a manner and speed resulting in trim angles that cause visibility to be obscured. Motor trim, hull trim plane and speed are factors that affect a boat's trim angle.

REFER TO OWNER'S PACKET FOR COMPLETE INSTRUCTIONS AND WARRANTY INFORMATION.

Trim Tabs
Figure 3.14.1

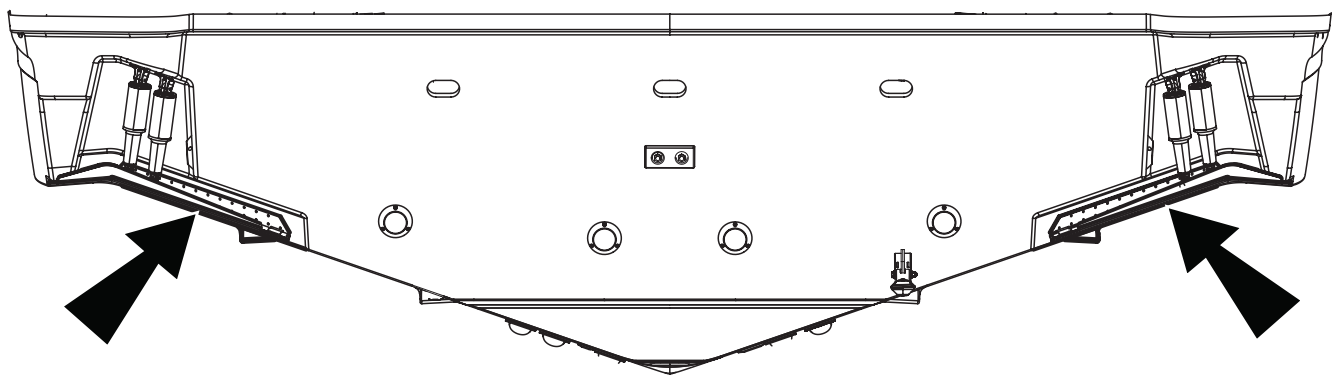

Operation

The trim tabs are controlled by rocker switches located at the helm console. Short momentary bursts of the rockers will achieve proper attitude of the hull. The trim tab switch is marked bow up and bow down. Using the trim tabs can level the boat; fore and aft, port and starboard; reduce steering system resistance; increase speed; reduce engine strain; and provide a smoother, more stable ride.

NOTICE

Ensure continuous visibility of other boats, swimmers and obstacles during bow-up transition to planing. Adjust engine to an intermediate trim as soon as boat is on plane to avoid possible ejection due to boat spinout. Do not attempt to turn boat when the engine is trimmed extremely down, under or in.

INSTRUCTIONS AND WARRANTY INFORMATION.

Auto Glide Boat Control System

The auto glide system uses engine and GPS data to drive this vessel to the most efficient running angle by adjusting the trim tabs as needed. With auto glide, this vessel's running angle is measured 25 times per second, with this data used to automatically set efficient running angle; reduce bow rise during initial acceleration; eliminate bow porpoising (bow bounce); and keep vessel level at all times. Although auto glide is normally kept in auto mode, convert to manual mode by pressing one of the four up/down buttons on the key pad).

REFER TO OWNER'S PACKET FOR COMPLETE INSTRUCTIONS AND WARRANTY INFORMATION.

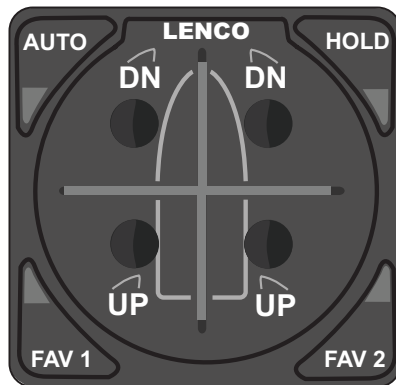

Dynamic Running Surface™ (Trim Tabs)

ATTENTION

Visibility from the helm station may be limited, use of trim tabs may be necessary to maintain adequate visibility in some running conditions. Avoid serious injury or death from collisions. Maintain a lookout as required by USCG navigation rules.

The electric trim tabs on this vessel are of a unique design which further enhances the ride and handling of this vessel (see Figure 3.15.1). Trim tabs are located on the bottom of the hull at the transom and are used to assist in leveling the vessel caused by uneven weight distribution or strong cross winds.

Maintenance

The trim tabs units are sealed, waterproof and maintenance free. General cleaning is recommended, and marine growth should be removed when the boat is out of the water. Also inspect the sacrificial anodes regularly and replace as necessary, refer to chapter 5, *Care & Maintenance* for additional information.

REFER TO OWNER'S PACKET FOR COMPLETE INSTRUCTIONS AND WARRANTY INFORMATION.

Dynamic Running Surface
Fig. 3.15.1

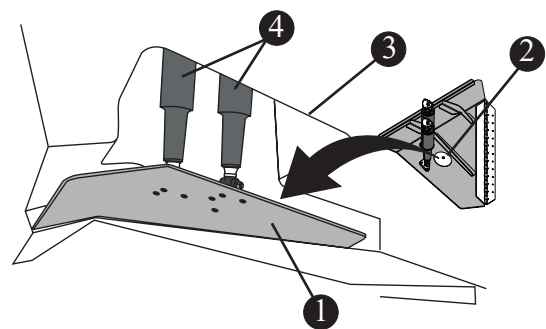

- 1 DYNAMIC RUNNING SURFACE
- 2 SACRIFICIAL ANODE
- 3 TRANSOM
- 4 ACTUATORS

Power Steering System

The Verado four-stroke engines use an enclosed hydraulic pump unit that provides hydraulic pressure to the steering system (see Figure 3.16.1). The pump is located in the aft of the bilge and can be accessed via the aft mechanical access hatch.

Filling and Maintenance

The system is virtually maintenance free, aside from regular fluid level checks and visually inspecting the outside of the unit for signs of leaks or damage. To inspect power steering fluid level:

1. Remove pump cover by unlocking tabs on sides.
2. Unscrew cap and check fluid level. Add SAE 0W-30 synthetic steering fluid, if necessary.
3. Replace cap and cover.

Check fluid level before each trip. Proper maintenance of this system ensures worry-free usage for the life of this vessel. Steering system integrity is imperative when engaging in recreational water activities. All steering systems whether mechanical or hydraulic require regular inspections, periodic adjustment, and occasional replacement may be necessary. Special

care and attention must be taken to ensure proper performance of the steering system and should include the following:

- After first few hours of operation and at regular intervals, check all fasteners and the complete steering system for security and integrity.
- Inspect for corrosion. Any part affected by corrosion must be replaced.
- When replacing parts, use locking hardware.
- Check fluid level in helm pump unit.
- Lubricate slides on engine cylinders.

REFER TO THE ENGINE MANUFACTURER'S MANUAL IN YOUR OWNER'S PACKET FOR COMPLETE INSTRUCTIONS AND WARRANTY.

ATTENTION

Optional Mercury V12 engines do not have external power steering pumps and instead use a built-in, electro-hydraulic steering motor. Steering commands between helm/joystick and engine are digital.

Power Steering System*
Figure 3.16.1

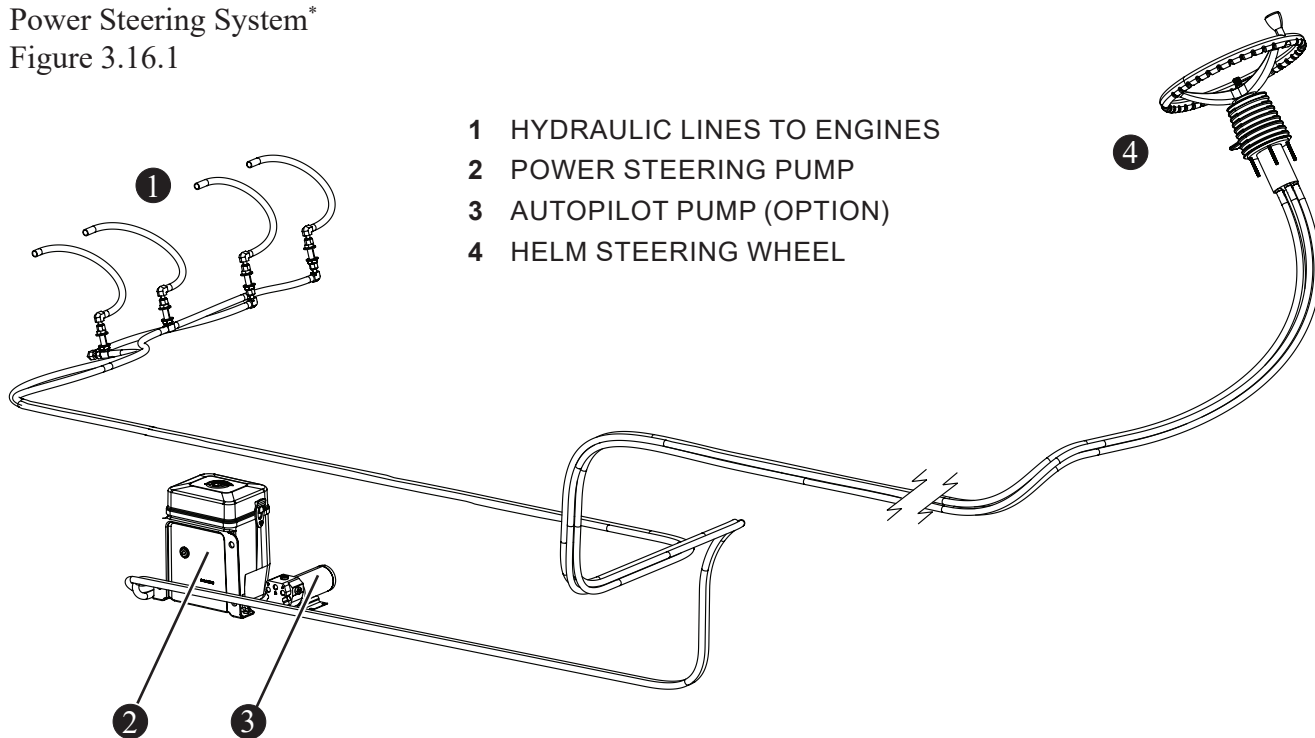

NOTE: When equipped with optional joystick piloting and/or V12 engines, power steering configuration varies.

Freshwater System

NOTICE

Only fill freshwater tank from a safe drinking water source. If tank is not used for long periods of time, disinfect system before using.

The freshwater system (see Figure 3.18.1) includes a 90 gal. (340 L) freshwater tank and pump providing water to the sink/shower in the head, galley sink, toilet, and transom/dive door showers. The system is automatically on as soon as the boat is powered up. All components of the freshwater system are FDA approved as a source of potable water. Fill the tank from a source known to provide safe, pure drinking water. Refer to chapter 5, *Care & Maintenance* for disinfection instructions. The freshwater fill is located on the starboard walkway (see chapter 2, *General Information*). Use a plastic hose to fill tank as a rubber hose may give the water a disagreeable taste. Store hose in a clean, dry place; cover hose ends to ensure it stays clean.

Freshwater Pump

The freshwater pump (see Figure 3.17.2) draws water from the water tank and provides pressurized water to various locations such as the galley, head compartment, freshwater showers, the prep station and other locations. As soon as the boat is powered

up, freshwater is ready to flow. To turn off freshwater at the helm display, tap the *WHALER* app, then tap on *SWITCHES*. On the switches screen tap on the *FRESH* button under *PUMPS* to activate the system, button will illuminate (see Figure 3.19.1). Freshwater tank level is monitored from the *GAUGES* screen by tapping the *FLUIDS* button (see Figure 3.17.1). If water level in tank level falls below 3 percent, the fresh water pump automatically turns off after 2 minutes.

Freshwater Pump

Figure 3.17.2

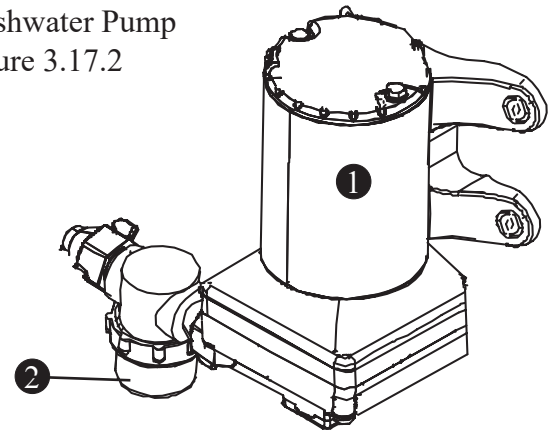

1 FRESHWATER PUMP 2 IN-LINE STRAINER

Freshwater Faucet

This vessel is equipped with two freshwater washdown faucets, one in the bow locker and the second at the port stern (see Figure 3.18.2). The faucet fits a common garden hose.

Freshwater Tank Level

Figure 3.17.1

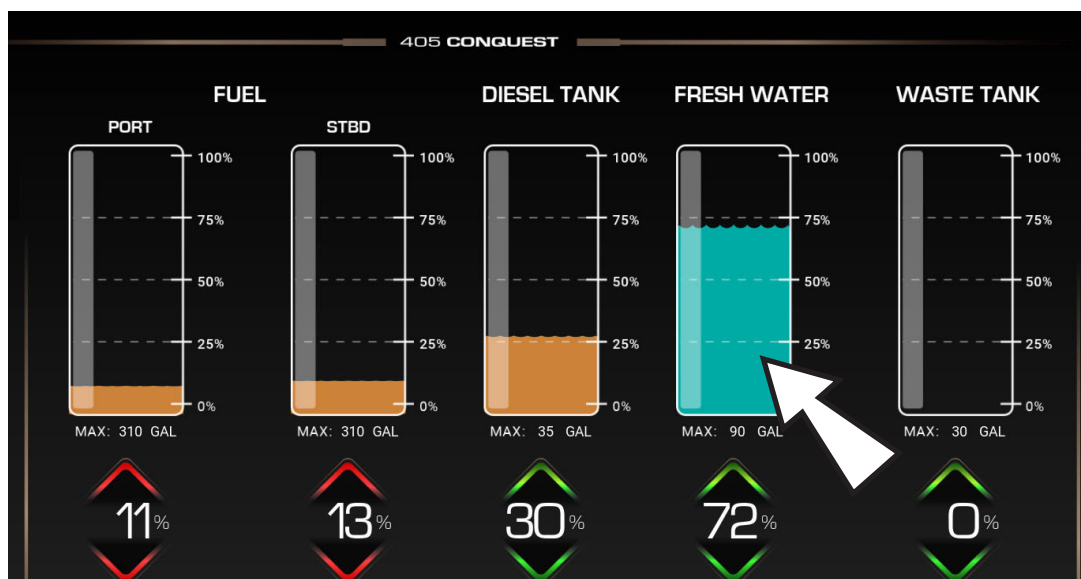

Freshwater System
Figure 3.18.1

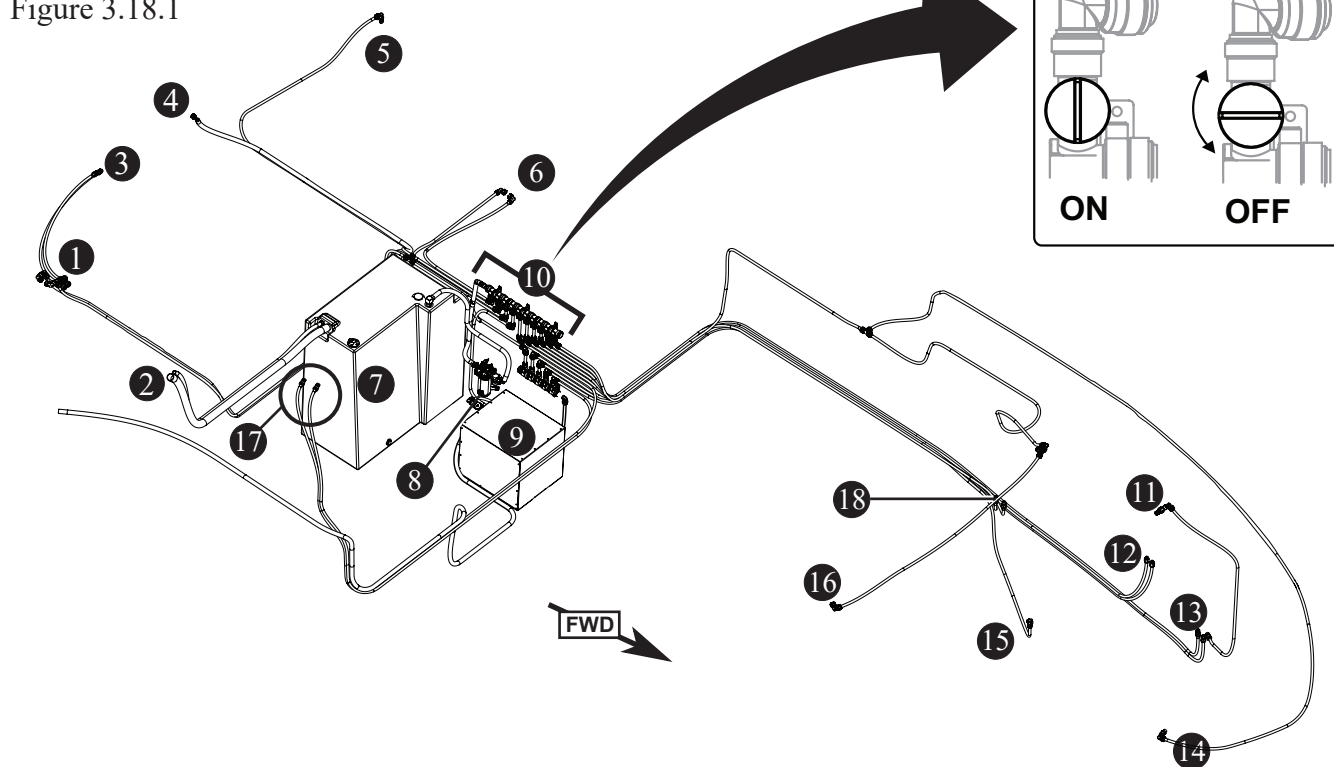

- | | |
|----------------------------------|-------------------------------|
| 1 FRESHWATER SHOWER | 10 FRESHWATER SYSTEM MANIFOLD |
| 2 FRESHWATER FILL DECK PLATE | 11 HEAD OVERHEAD SHOWER |
| 3 SUMMER KITCHEN FAUCET (OPTION) | 12 HEAD SINK |
| 4 DOCKSIDE WATER INLET | 13 HEAD PULL-OUT SHOWER |
| 5 FRESHWATER WASHDOWN | 14 BOW FRESHWATER FAUCET |
| 6 FRESHWATER SHOWER | 15 TOILET FRESHWATER SUPPLY |
| 7 FRESHWATER TANK | 16 WINDSHIELD WASHER |
| 8 WATER PUMP | 17 PREP STATION SINK |
| 9 WATER HEATER | 18 GALLEY SINK |

Bow and Stern Freshwater Faucet
Figure 3.18.2

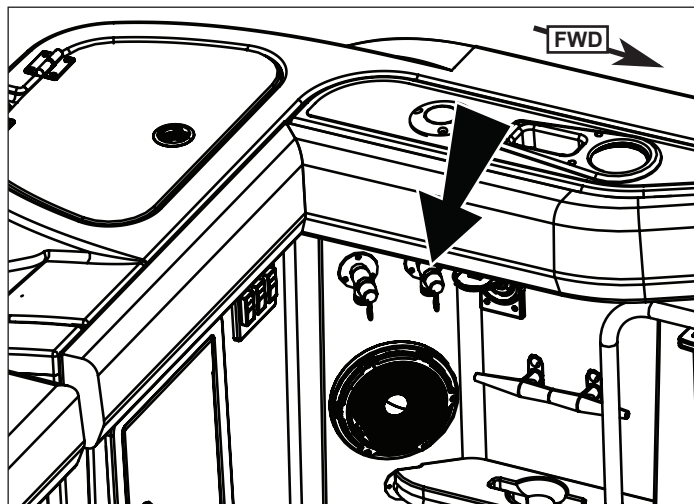
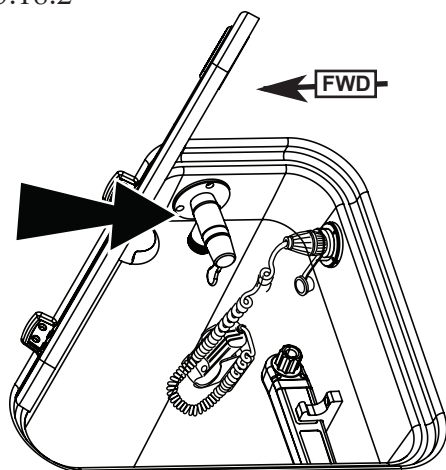

Switches Tab, Raw Water
Figure 3.19.1



Freshwater Shower

There are two freshwater showers on this vessel (see Figure 3.19.2), one outside the transom door and the second near the dive door. The shower unit is pressurized by the fresh water pump and the spray head is activated by twisting the center of the unit.

Freshwater Showers
Figure 3.19.2

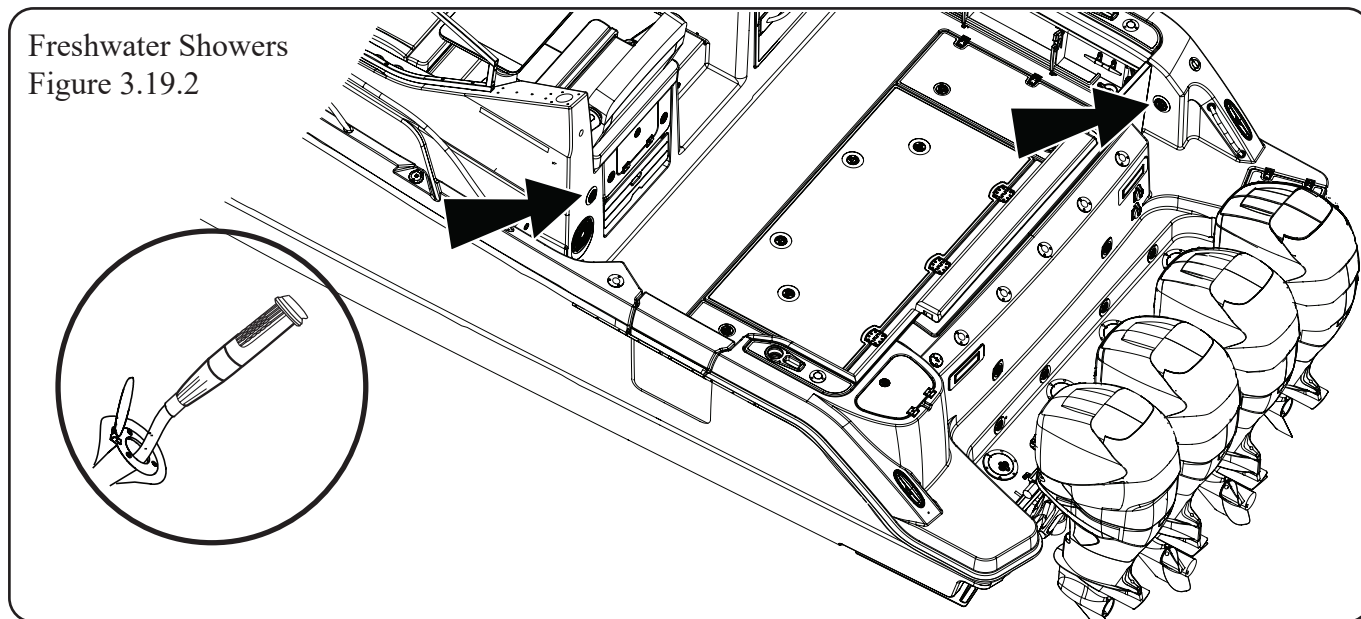

Raw Water System

The raw water system includes a pump, a seacock with auxiliary pump, and one washdown hose connection. To activate raw water system:

1. In the aft mechanical access hatch, check to ensure seacock is open (see Figure 3.22.1).
2. On the helm display tap on the *WHALER* app, then tap on *SWITCHES*. On the switches screen tap on the *RAW* button under *PUMPS* to activate the system, button will illuminate (see Figure 3.21.1); system is now in standby mode and raw water is available on demand.

Switches Tab, Raw Water
Figure 3.21.1



Raw Water System
Figure 3.21.1

ATTENTION

Seacock must be in open position when raw water system is in use. Running pump dry may damage unit.

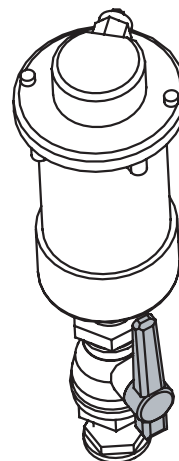
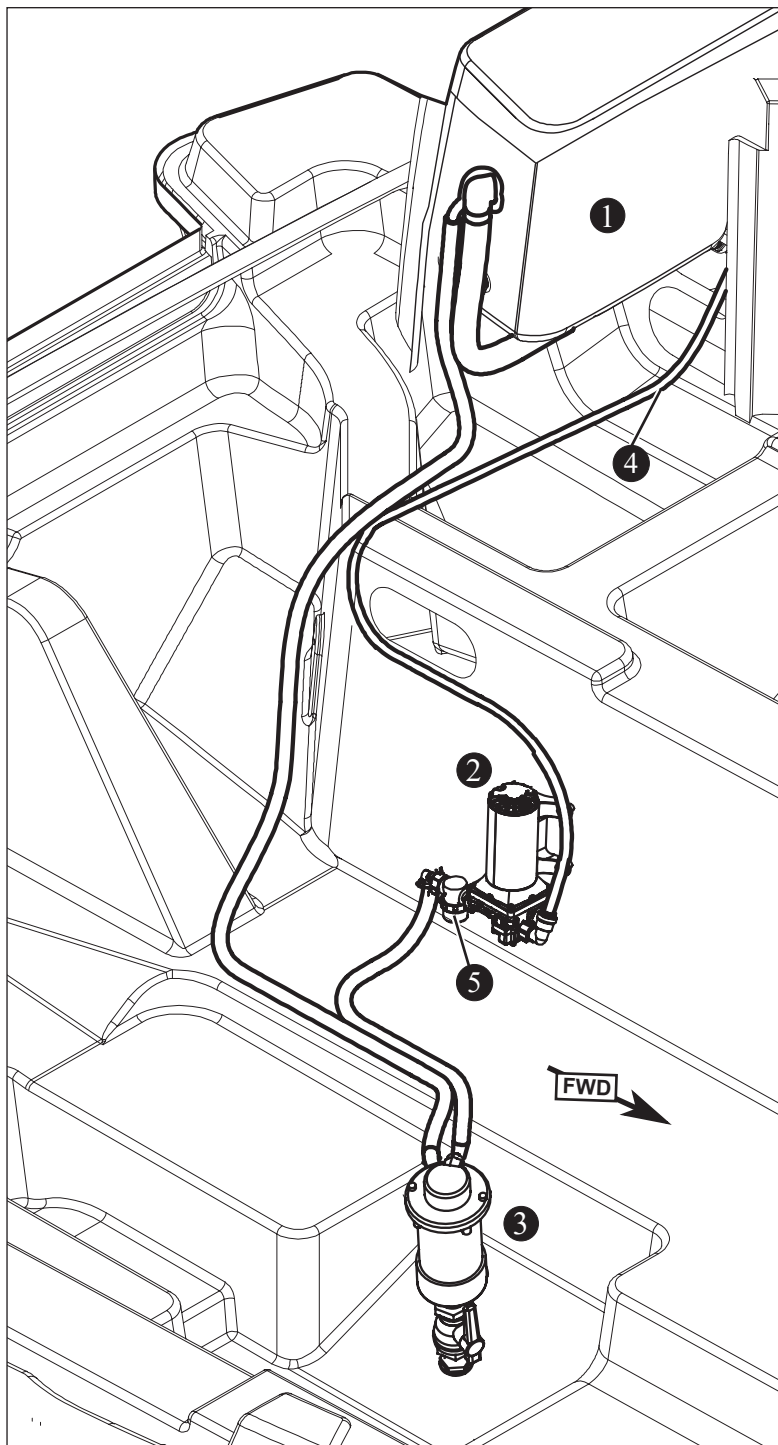

OPEN

3

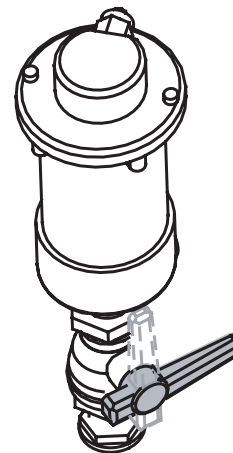

CLOSED

- 1 LIVWELL
- 2 RAW WATER PUMP
- 3 SEACOCK
- 4 TO RAW WATER WASHDOWN
- 5 IN-LINE STRAINER

Raw Water Washdown

This vessel is equipped with one raw water washdown faucet located at the port transom (see Figure 3.22.1). The fitting allows connection of a common garden hose (not included).

Maintenance

Maintenance of the raw water system requires periodic inspection of the raw water intake strainer and all fittings and hoses for system integrity to prevent leaks. Clean away debris and/or tighten hose connections as required. The system should be run at least every other month to keep the pumps impellers in good condition.

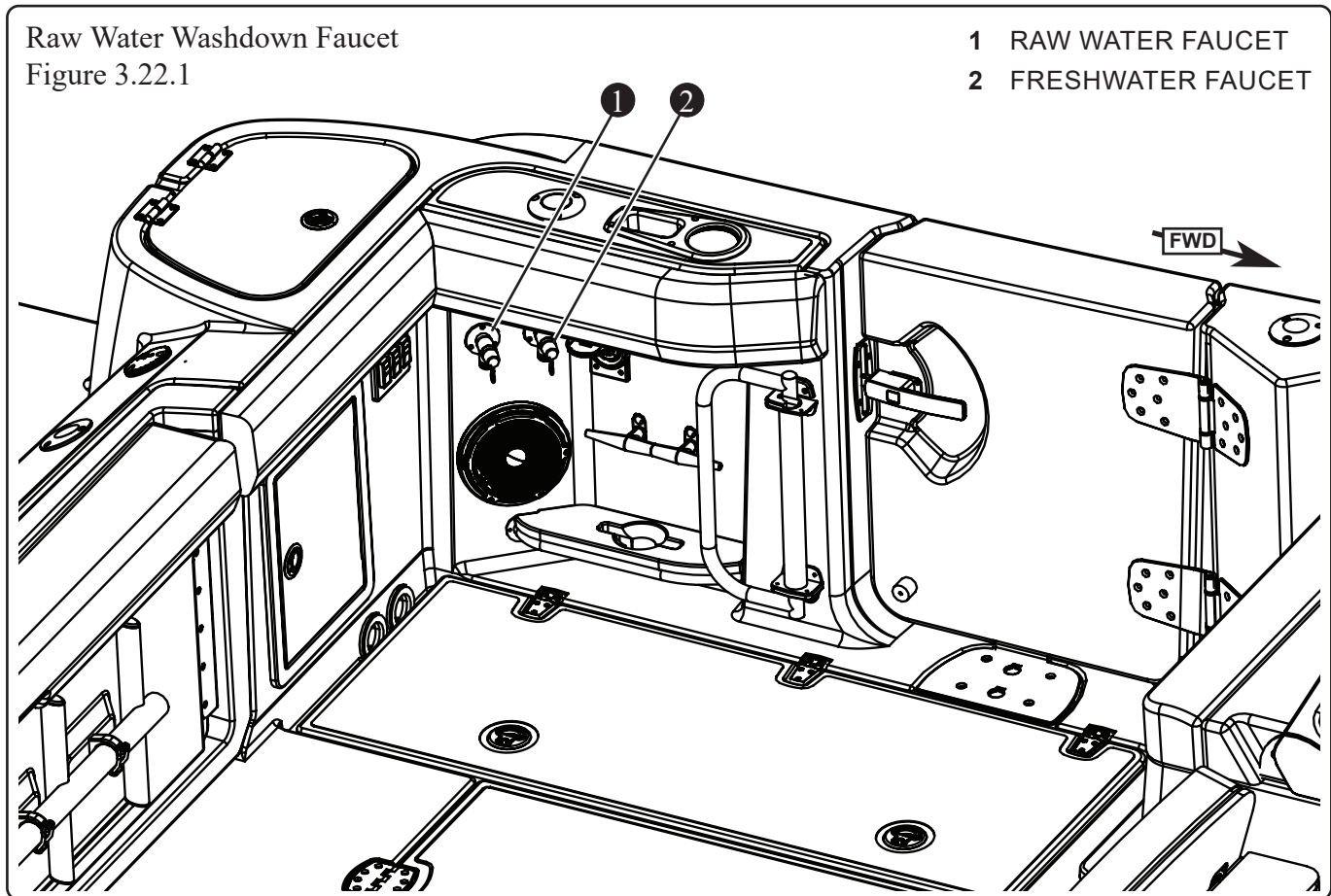

Livewell

The livewell, located at the port transom, is used to keep baitfish alive by circulating seawater through the tank.

1. Insert livewell lower drain plug (see Figure 3.23.1) and ensure seacock is in open position (see Figure 3.21.1).
2. Open livewell flow control valve. Overflow drain allows water to rise near top before draining.
3. Fill livewell by pressing switch marked *LIVWELL* at the stern, below the livewell.
4. Remove lower drain plug to empty.

ATTENTION

Seacock must be in open position when livewell is in use. Running pump dry may damage unit.

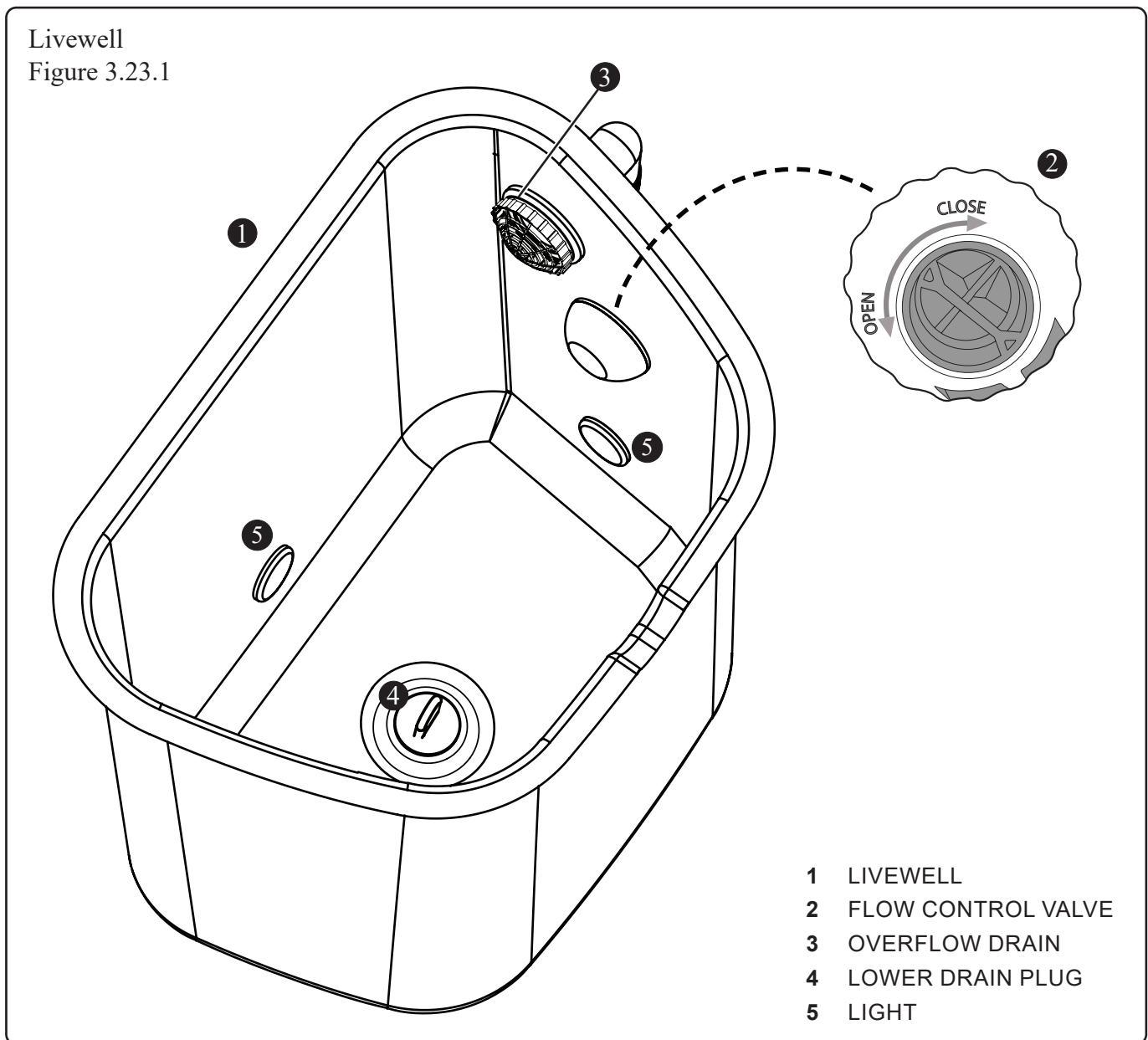

Head System

Environmental Considerations

The Environmental Protection Agency (EPA) standards state that in freshwater lakes, reservoirs, impoundments whose inlets or outlets are such as to prevent the ingress or egress by vessel traffic subject to this regulation, or in rivers not capable of navigation by interstate traffic subject to this regulation, marine sanitation certified by the United States Coast Guard (U.S.C.G.) installed on vessels shall be designed and operated to prevent the overboard discharge of sewage, treated or untreated or any other waste derived from sewage. The EPA standards further state that this shall not be construed to prohibit the carriage of Coast Guard certified flow through treatment devices which have been secured so as to prevent such discharges. They also state that the waters where a Coast Guard certified marine sanitation device permitting discharge is allowed include: Coastal waters, Estuaries, The Great Lakes and Intercoastal waterways, Freshwater lakes and Impoundments accessible through locks and other flowing waters that are navigable interstate by vessels subject to this regulation. (40CFR 140.3)

NOTICE

This boat is equipped with an overboard discharge seacock. Severe state and federal penalties are levied for discharging raw sewage and solid waste in waters where it is not permitted. Disable macerator by attaching a zip tie or padlock to seacock or by removing seacock handle while in a closed position, which would avoid potential fines. It is illegal for any vessel to dump plastic trash anywhere in the ocean or navigable waters of the United States.

NOTICE

The low-water consumption waste system requires the use of special paper to prevent clogs. The manufacturer has provided information regarding the type of paper that must be used. Never use residential tissue paper in your marine waste system.

Waste System

This vessel is equipped with a waste containment/disposal system (see Figure 3.24.1). The system

includes a VacuFlush® toilet, holding tank with vent filter, overboard discharge, waste pumpout, tank and a full indicator alert, and a progressive tank level indicator integrated into the helm display. Waste from the head is directed into the holding tank located inside the forward mechanical access hatch. The macerator/discharge pump draws solid and liquid waste from the holding tank and processes it prior to discharging it overboard through the seacock located in the aft bilge. The macerator pump is designed to handle waste, toilet/facial tissue and does not pump solid waste. The key used to actuate the overboard discharge unit can be found in the owner's packet. To operate the VacuFlush toilet:

1. In cabin, on the DC main distribution panel, turn on *VACUUM GEN* switch.
2. Press and hold *ADD WATER* button to partially fill toilet bowl (see Figure 3.25.1).
3. Press *FLUSH* button to flush toilet.

NOTE: If discharge panel's red light is on, empty holding tank for system to function properly.

Waste System
Figure 3.24.1

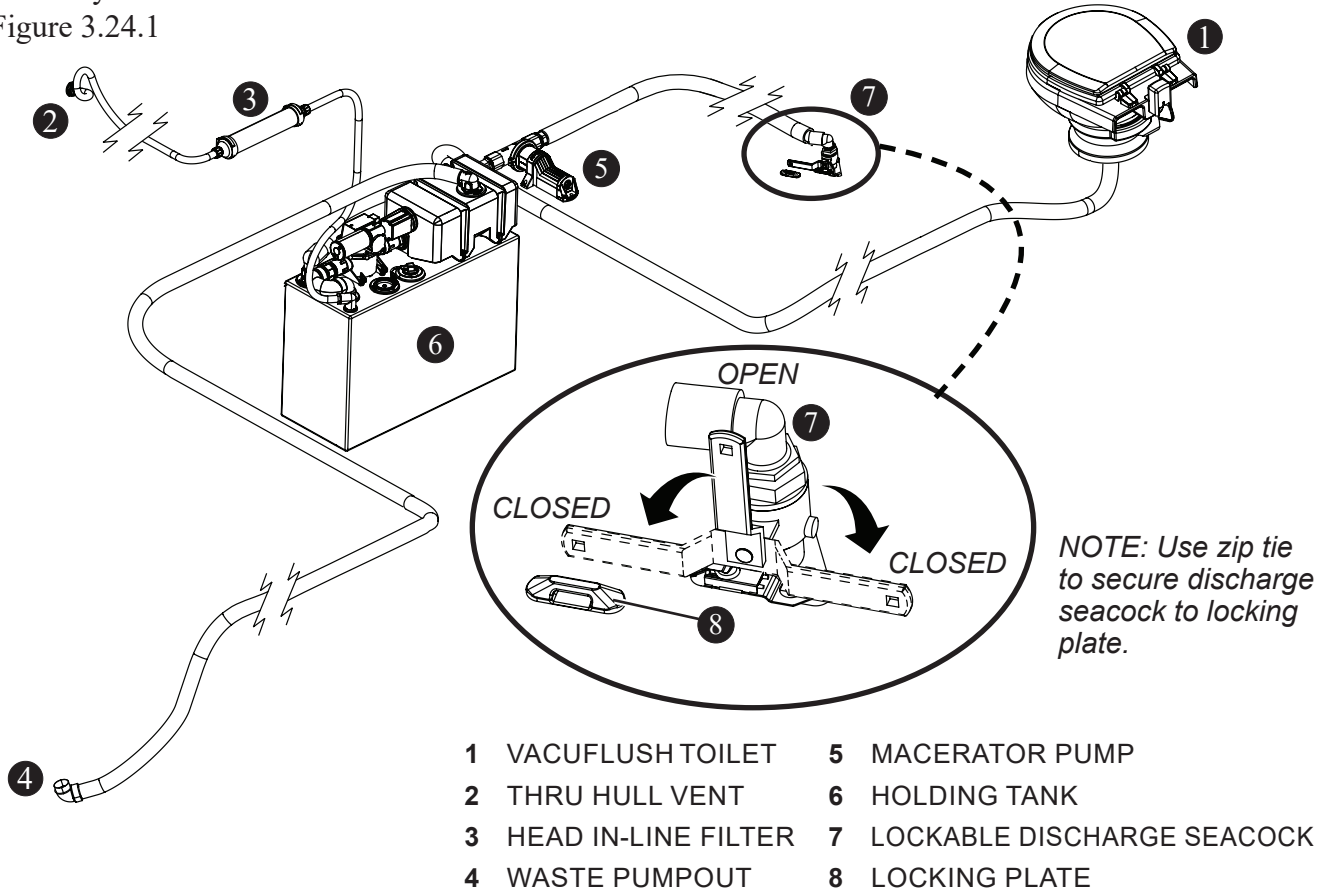

Overboard Discharge of Waste

The *OVERBOARD DISCHARGE* control panel (see Figure 3.25.1) is located in the head next to the VacuFlush toilet (see Figure 3.24.1). If the *DO NOT FLUSH* light is illuminated, empty the holding tank as follows:

1. Ensure lockable discharge seacock is in open position (see Figure 3.24.1).
2. Insert macerator key (included in owner's packet) into panel; turn key clockwise.
3. Press and hold *PUSH TO DISCHARGE* button until waste holding tank is empty. To confirm tank is empty either visually inspect tank (located in forward mechanical access hatch) or check waste tank level indicator on helm display's *SYSTEMS* tab.
4. Turn the key counterclockwise.
5. Ensure lockable discharge seacock is in closed position (see Figure 3.24.1).

NOTICE

Severe state and federal penalties are levied for discharging raw sewage and solid waste in waters where it is not permitted.

WARNING

Keep lockable discharge seacock in closed position when toilet is not in use. Failure to do so could result in flooding or property damage.

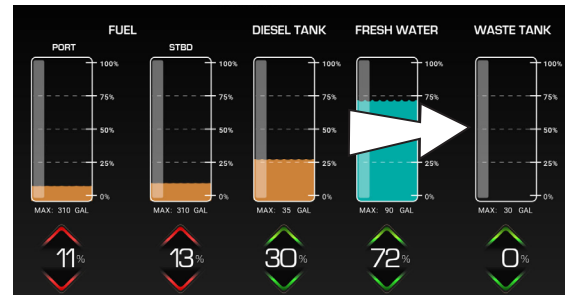

REFER TO THE OWNER'S PACKET FOR COMPLETE INSTRUCTIONS AND WARRANTY INFORMATION.

Overboard Discharge
Figure 3.25.1

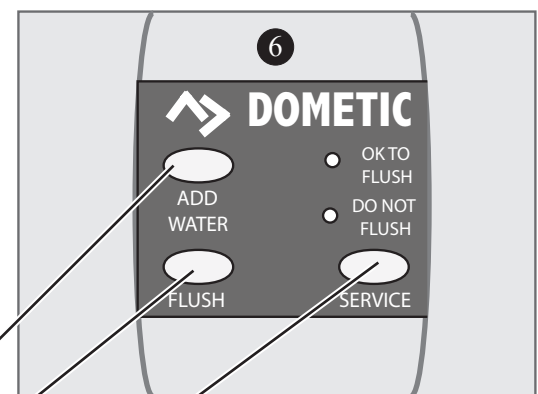
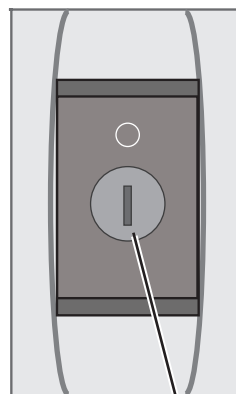
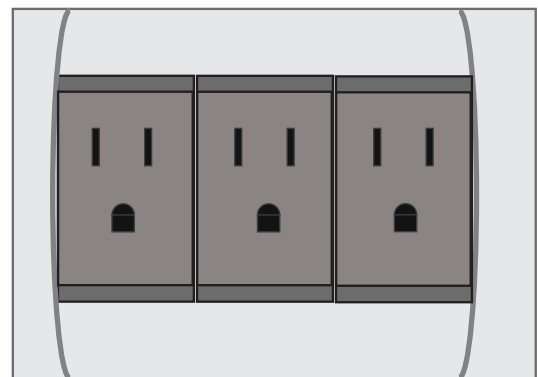
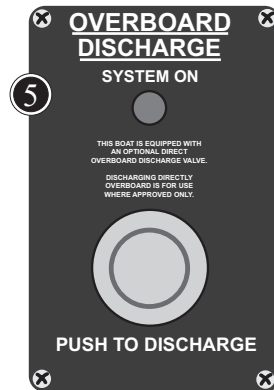

- 1 MACERATOR KEY SLOT
- 2 FLUSH (VACUUM PUMP)
- 3 SERVICE*
- 4 ADD WATER (PRIOR TO FLUSH)
- 5 OVERBOARD DISCHARGE PANEL
- 6 TOILET PANEL

*REFER TO THE OWNER'S PACKET FOR COMPLETE INSTRUCTIONS AND WARRANTY INFORMATION.

Macerator and Dockside Discharge

NOTICE

Dockside discharge is the preferred method of waste disposal. Close macerator pump discharge seacock prior to using the dockside discharge function.

The system can be emptied by means of dockside pumpout (preferred) through the deck plate on the port transom. The system also provides for overboard discharge by way of a macerator and lockable discharge seacock. The seacock is disabled by locking the handle in place using a zip tie between the handle and the locking plate. Demonstrating the macerator is disabled may help avoid a fine. The seacock can also be disabled by removing the seacock handle. There are bodies of water where discharge of raw sewage is prohibited. Keep the seacock lock engaged (see Figure 3.25.1) when in waters where discharge is not permitted. Contact your dealer or local Coast Guard station for information on overboard discharge in your area and the penalties for non-compliance. To lock the discharge seacock, rotate handle until the hole in the handle is aligned with the locking plate hole; insert a padlock (not included).

Maintenance

NOTICE

The low-water consumption waste system requires the use of special paper to prevent clogs. The manufacturer has provided information regarding the type of paper that must be used. Never use residential tissue paper in your marine waste system.

After long periods of non-use, the macerator pump may not turn freely. Regular use of the system reduces the chances of this occurring. If the system does require maintenance contact your dealer. Because your waste system is low-water consumption, there is special paper which must be used to prevent clogs.

REFER TO OWNER'S PACKET FOR COMPLETE INSTRUCTIONS AND WARRANTY INFORMATION.

Waste System Vent

NOTICE

Replace filter at beginning of each boating season for most effective odor control.

NOTICE

If holding tank overflow occurs and vent filter becomes fouled, replace vent filter immediately.

The waste system vents odors associated with waste operations via a thru hull vent (see Figure 3.24.1).

Vent Filter Replacement

The vent's in-line filter is located in the forward mechanical hatch. To replace:

1. Unscrew vent hose fittings from old vent filter
2. Remove old filter from bracket, seal open ends with tape or wrap inside plastic bag, and discard
3. Install new vent filter in bracket and attach to vent hose fittings.

Air Conditioning (A/C)

This vessel is equipped with four reverse-cycle air conditioning systems (see Figure 3.28.1):

LOCATION	UNIT SIZE
MAIN CABIN A/C	16000 BTU
STARBOARD HELM DECK A/C	16000 BTU
PORT HELM DECK A/C	12000 BTU
STATEROOM A/C	8000 BTU

The air conditioning/heating system is controlled at the helm display or by separate display panels located in the cabin and stateroom. For display panel locations refer to chapter 2, *General Information*. The helm display allows the operator to preset the temperature. Once on and the temperature is set, the A/C units activate automatically when the temperature of the cabin/helm is not consistent with the preset temperature. When the A/C is turned on, raw water is pumped through a strainer, passes through the system and then flows overboard through a thru-hull.

Start the Air Conditioning (A/C)

1. Ensure raw water intake seacock is open (see Figure 3.27.1 and Figure 3.28.1).
2. Turn on both pump breakers on the main AC distribution panel located in the cabin.
3. Turn on all A/C breakers on the main AC distribution panel located in the cabin.
4. Set the desired temperature at the helm display, an A/C display in the cabin, or in the stateroom. For additional information refer to *Digital Switching* in chapter 4, *Electrical*.

REFER TO OWNER'S PACKET FOR COMPLETE INSTRUCTIONS AND WARRANTY INFORMATION.

A/C System

Figure 3.27.1

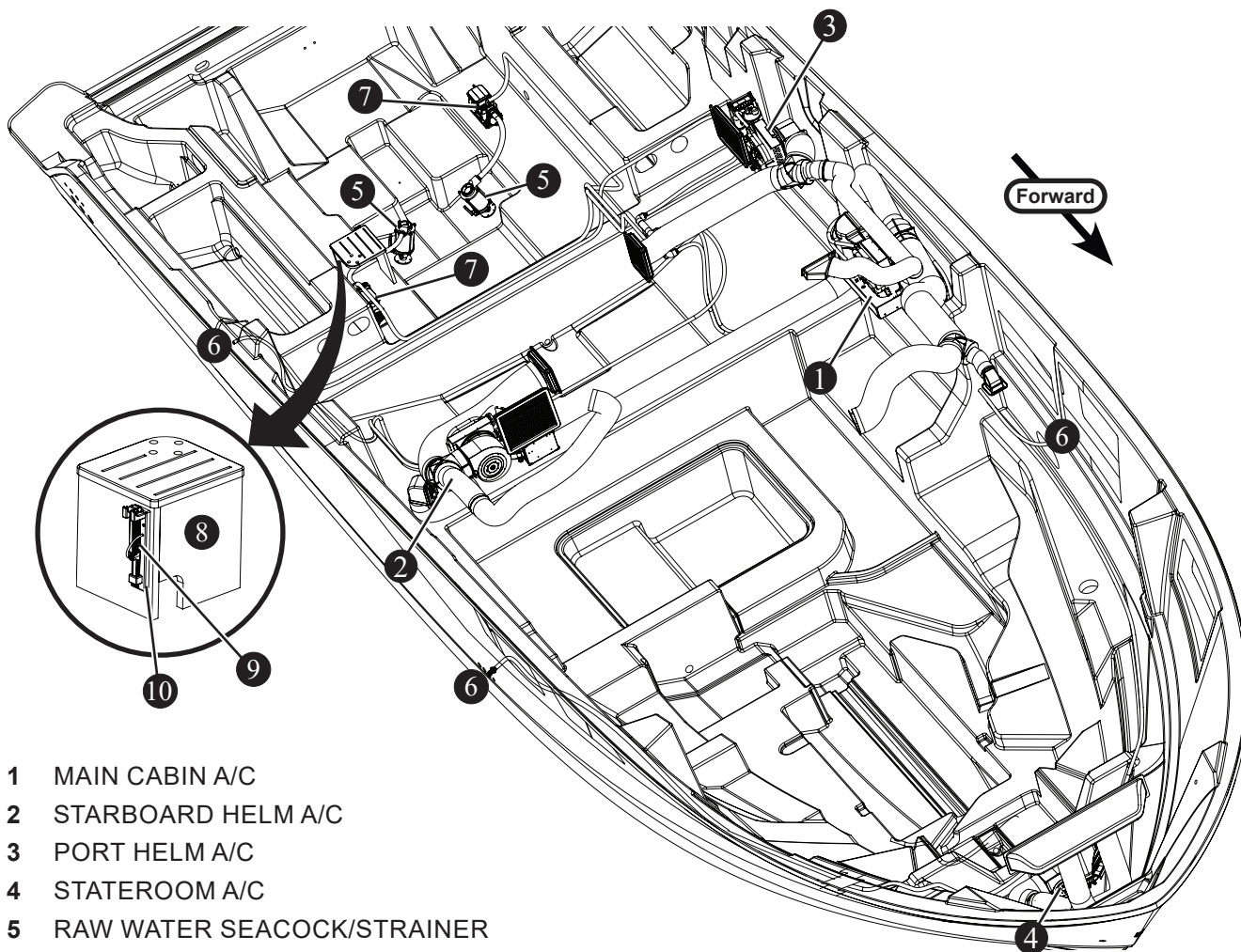

- 1 MAIN CABIN A/C
- 2 STARBOARD HELM A/C
- 3 PORT HELM A/C
- 4 STATEROOM A/C
- 5 RAW WATER SEACOCK/STRAINER
- 6 THRU-HULL DRAIN
- 7 A/C PUMP
- 8 MECHANICAL ACCESS STEP
- 9 TWO-PRONGED SPANNER TOOL
- 10 SPANNER TOOL STORAGE BRACKET

Air Conditioning (A/C) Raw Water Strainer

The air conditioning system, has two raw water pumps to cool the A/C units located inside the mechanical access hatch, (see Figure 3.27.1). Each pump has a *Raw Water Seacock/Strainer*. Periodically check the strainers for debris and clean as necessary (see Figure 3.28.1). To inspect strainer:

1. Ensure A/C units are turned off.
2. Close intake seacocks (see Figures 3.27.1 and 3.28.1).
3. Using *TWO-PRONGED SPANNER TOOL*, mounted on the *MECHANICAL ACCESS STEP* (see Figure 3.27.1 and Figure 3.28.1); unscrew strainer cover.
4. Remove internal *FILTER* and remove debris.
5. Replace the strainer and secure cover.

NOTE: If A/C system does not functioning properly after cleaning seacock/strainer and water is not draining from the A/C thru-hull, flush the system as described in *Flushing Air Conditioning System*. If flushing doesn't resolve the issue, contact a Boston Whaler dealer for service.

Flushing Air Conditioning System

When the boat is not in use, debris can settle inside the A/C pumps. This can interfere with pump impeller operation causing the A/C unit to overheat and shutdown. Flush the system with freshwater upon returning to the dock or any time the boat is left in the water any length of time with the A/C seacocks open. To flush the system:

1. Ensure A/C units are turned off; close *RAW WATER SEACOCK /STRAINER* (see Figure 3.27.1 and Figure 3.28.1).
2. Using the *TWO-PRONGED SPANNER TOOL* (see Figure 3.28.1), turn strainer cap counter clockwise to loosen; remove and set aside.
3. Screw in *FLUSH CAP*, located in the owner's packet (see Figure 3.28.1). Tighten clockwise with spanner tool.
4. Attach a garden hose to *HOSE FITTING* on the flush cap. Turn on water and run for 10 minutes.
5. Turn off freshwater and replace strainer cap. Tighten with spanner tool and repeat process on second A/C strainer.

Raw Water Seacock/Strainer

Figure 3.28.1

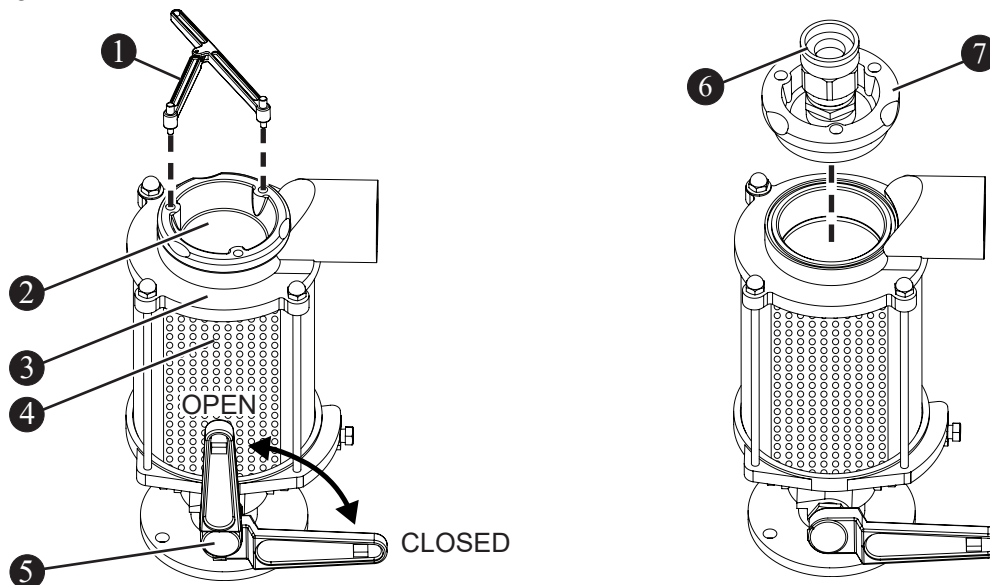

- 1 TWO-PRONGED SPANNER TOOL
- 2 STRAINER CAP
- 3 STRAINER
- 4 FILTER

- 5 SEACOCK
- 6 HOSE FITTING
- 7 FLUSH CAP

Water Heater

This vessel is equipped with a water heater, located in the forward mechanical access hatch, that supplies hot water to all sinks and the head shower (see Figure 3.29.1). Ensure the helm display's *FRESH WATER* switch is on (as indicated by blue halo around switch) before energizing the water heater. Turn on the *WATER HEATER* breaker located on the AC main distribution panel. Once both the *FRESH WATER* switch and the *WATER HEATER* breaker are on, the system can be utilized. If the unit has not been used for some time it takes approximately 20 minutes to heat up.

A mixing valve is installed on the heater's hot water outlet (see Figure 3.29.1) to reduce the risk of scalding. The valve is factory set at its lowest temperature (100°F). The water temperature can be adjusted up to a maximum of 130°F by turning the valve counter-clockwise until the desired temperature is reached.

Maintenance

Water heater connections need to be inspected regularly. Access the water heater via the forward mechanical access hatch. If any leaks are detected around the water heater contact a Boston Whaler dealer. Manually operate the pressure relief valve at least once a year. This must be done when the water in the storage tank is cool. The system must be flushed several times per year, which helps prolong the life of the system. There is a protective cladding in the tank

that protects it from corrosion. The electro-galvanic action of the cladding material releases hydrogen from the water. If sulfur or any of its combinations are present the two will combine and produce hydrogen sulfide and a rotten egg odor. Hydrogen sulfide may also be present in the freshwater supply. Make certain that the system is completely drained before off-season storage; flush freshwater tank with a non-toxic anti-freeze before winter storage.

NOTICE

Ensure fresh water tank is full before operating water heater. Running water heater until empty will damage the system.

NOTICE

The water heater is equipped with a tempering valve and a pressure relief valve.

! WARNING

Hydrogen gas may form in tank if system has not been used for more than two weeks. Do not smoke or have any flame near an open faucet.

! CAUTION

To avoid scald risk, turn off heater and wait until water has cooled before opening drain valve.

Water Heater
Figure 3.29.1

- 1 WATER HEATER
- 2 PRESSURE RELIEF VALVE
- 3 WATER INLET (FROM MANIFOLD)
- 4 DRAIN FAUCET
- 5 COLD WATER LINE TO MIX (TEMPERING) VALVE
- 6 HOT WATER OUT

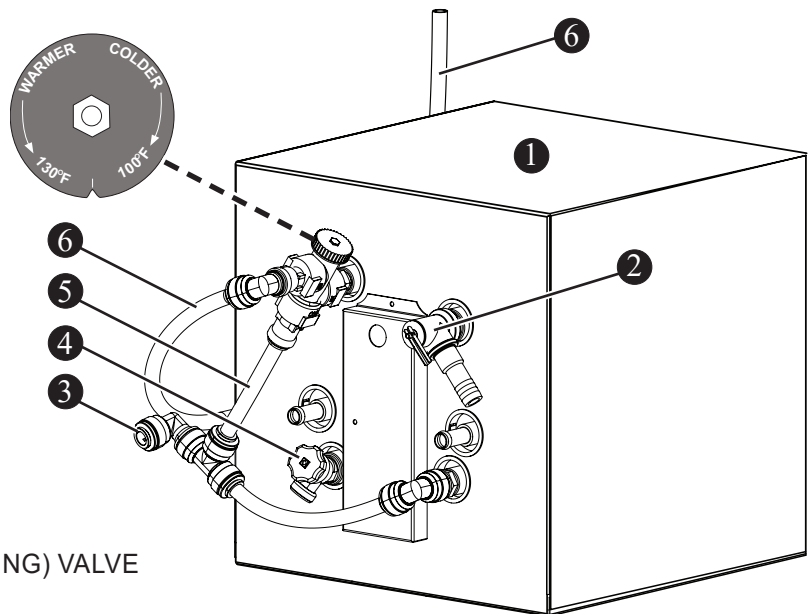

Engine Flush System (Option)

If equipped, the engine flushing system flushes salt and minerals from the internal engine components (see Figure 3.30.1).

Operation

1. Attach a garden hose to engine flush connection located at transom (refer to chapter 2, *General Information*).
2. To operate system, locate *ENG FLUSH OPERATION* panel at transom door (see Figure 3.30.1), and run either a full or half cycle as detailed below:

Full Cycle (15 minutes)

1. Push *ENG FLUSH OPERATION* button (see Figure 3.30.1) once to start. System cycles 15 minutes per engine.
2. Push *ENG FLUSH OPERATION* button twice to stop in the middle of cycle. Button is illuminated during cycle.

Half Cycle (7.5 minutes)

1. Push *ENG FLUSH OPERATION* button (see Figure 3.30.1) twice to start. System cycles 7.5 minutes per engine.
2. Push *ENG FLUSH OPERATION* button once to stop in the middle of cycle. Button flashes during cycle.

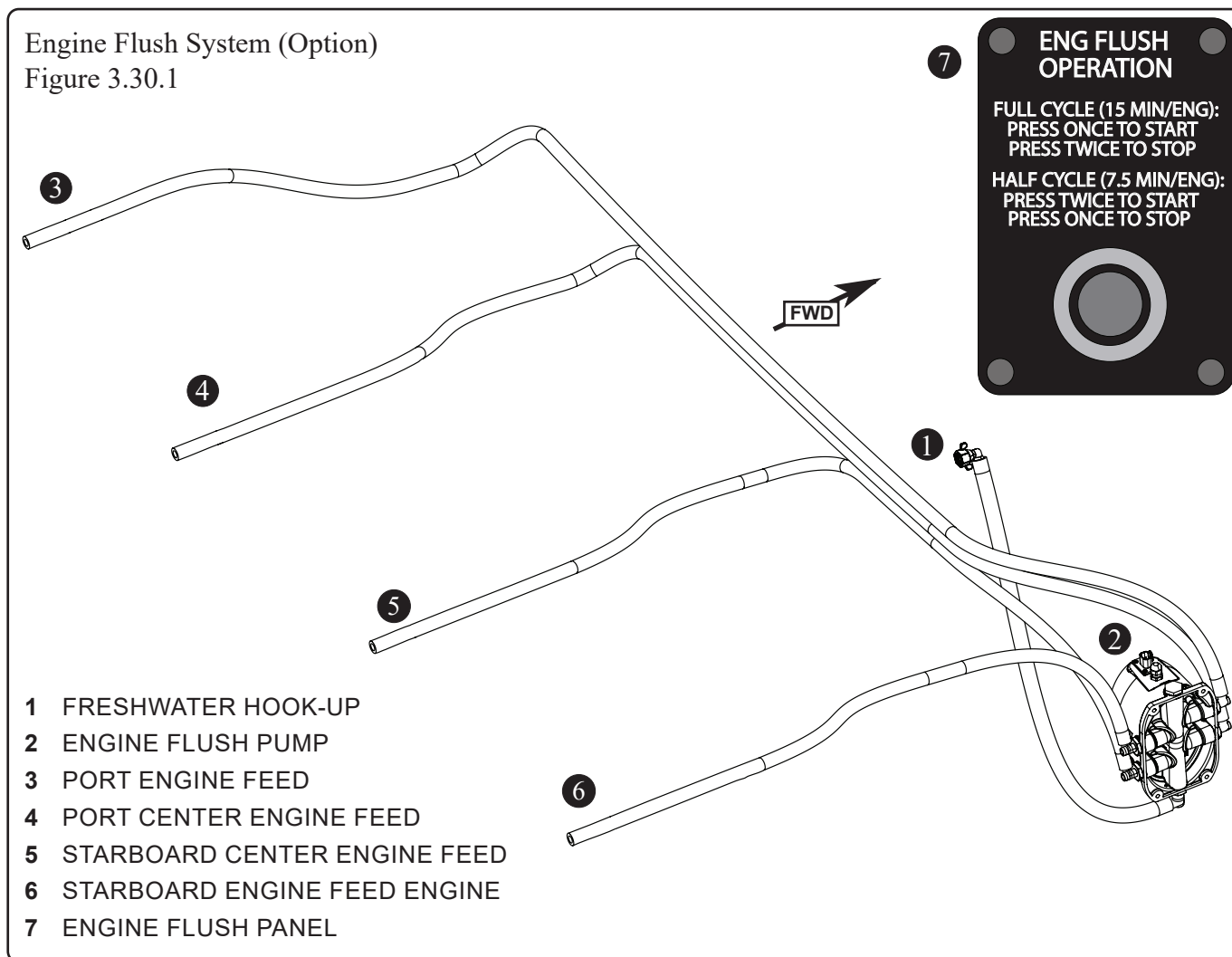

NOTE: When equipped with optional V12 engines, engine flush system configuration varies.

Diesel Generator System

ATTENTION

Ensure generator's raw water seacock is open before starting. Close seacock when generator is not in use to prevent damage while underway.

Read and understand the information in the generator manufacturer's manual before operating the unit. The diesel generator (see Figure 3.31.1) provides 240V AC power to the AC electrical system and has a built in cooling pump which draws raw water through a seacock located in the aft mechanical access hatch. Water passes through a strainer before entering the engine cooling manifold. Pull latches at the bottom of the sound containment housing to remove cover.

! WARNING

Carbon monoxide can cause severe nausea, fainting or death. The exhaust system must be leakproof and routinely inspected.

Fire can cause severe injury or death. Do not smoke or permit flames or sparks near fuels or the fuel system.

Explosive fuel vapors can cause severe injury or death. Use extreme care when handling, storing and using fuels.

Moving parts can cause severe injury or death. Operate the generator set only when all guards, screens and covers are in place.

Diesel Generator
Figure 3.31.1

NOTICE

Shut off generator before fuel level reaches designated run out of fuel level of 1/4 tank.

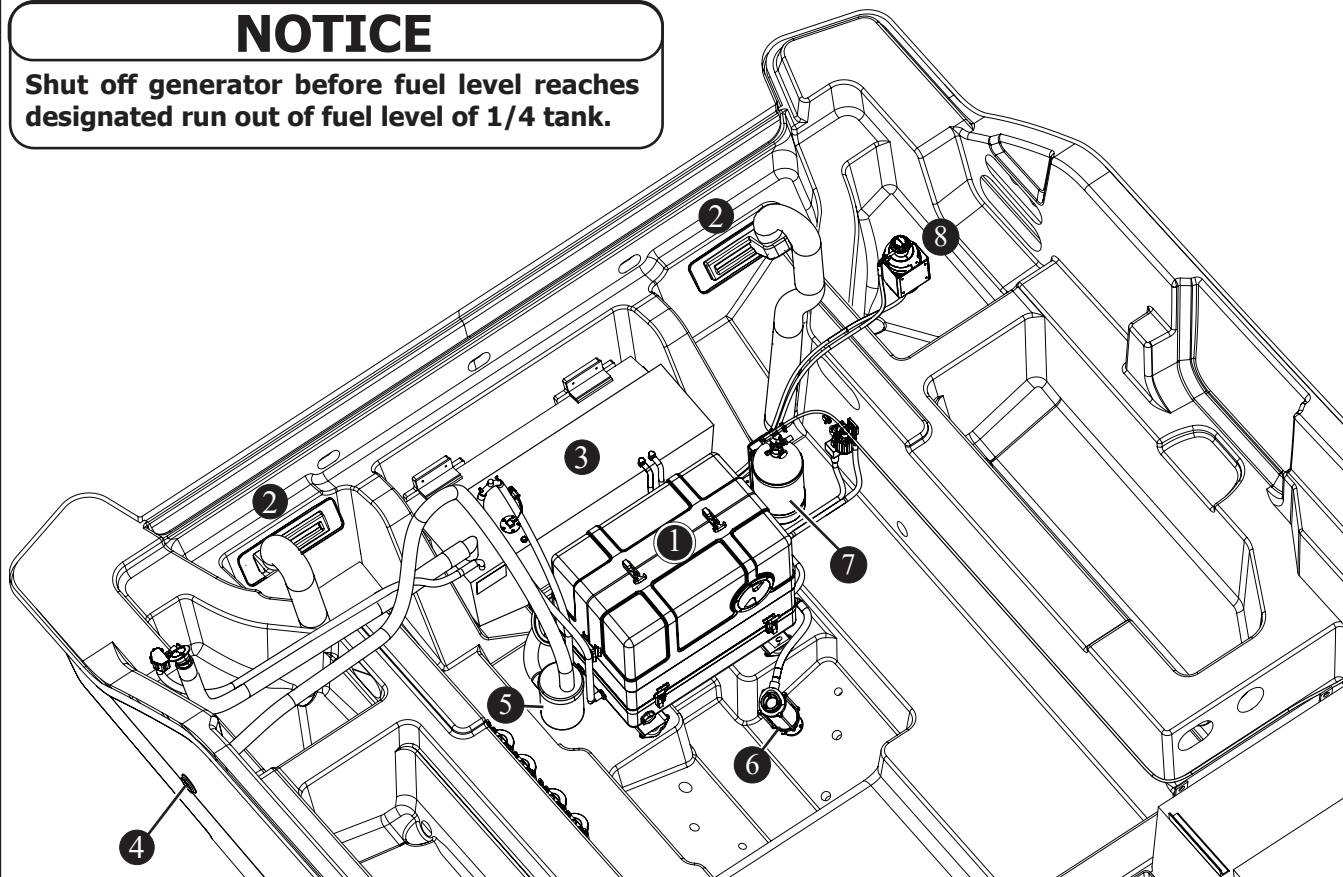

- 1 GENERATOR
- 2 BILGE VENTS
- 3 DIESEL FUEL TANK
- 4 GENERATOR EXHAUST VENT

- 5 MUFFLER
- 6 RAW WATER SEACOCK
- 7 FIRE EXTINGUISHER
- 8 EXPANSION TANK

Generator Fuel

NOTICE

If generator runs out of fuel it may be necessary to bleed the system before restarting unit.

Use #2 diesel fuel with a cetane number of 45 or greater. Clean fuel prevents the fuel injectors and pumps from clogging. Avoid storing fuel for more than a month and never store in galvanized containers. Keep dirt, water and other contaminants out of the fuel to prevent the growth of microbes. Microbes form slime that clogs the fuel filter and lines. Exhaust from the generator passes through a high-efficiency, water-lift type, water-cooled muffler and is discharged by a flexible hose via a hull fitting.

Generator Start-up

! CAUTION

Do not start generator if water has accumulated beneath generator.

REFER TO OWNER'S PACKET FOR COMPLETE INSTRUCTIONS AND WARRANTY INFORMATION.

Refer to the manufacturers operations manual for a pre-start checklist. The following steps outline several key points of generator operation:

1. Locate bilge blower (*BILGE BLWR*) switch on DC distribution panel (see Figure 3.33.1). Run blower for four minutes.
2. Inspect aft mechanical access hatch for fuel/ fumes.
3. Open generator's raw water seacock in aft mechanical access hatch.
4. Check to ensure all AC main distribution panel breakers are switched off (see Figure 3.34.1).
5. Check to ensure shore power breaker (*SHORE*) is off (see Figure 3.34.1); slide selector cover to

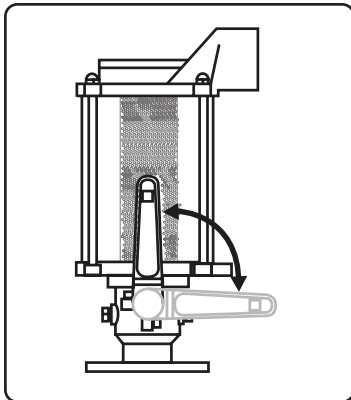

expose *GENERATOR* breaker.

6. Switch on DC distribution panel's *GENERATOR* switch.
7. Press *On/Off* button on generator display panel (see Figure 3.33.1). The screen's indicator light illuminates and fuel gauge is activated.
8. Press and release *Start/Stop* button (see Figure 3.33.1); indicator light blinks and generator starts.
9. After successful start-up, switch *GENERATOR* breaker on.
10. Turn on AC main distribution panel breakers as needed (see Figure 3.34.1).

NOTE: Do not press *Start/Stop* button more than once. If unit does not start, allow 60-second cool down between cranking attempts; check fuel flow, if ok, attempt start sequence again. If unit fails to start after three attempts, contact an authorized dealer/distributor for service.

For information on maintenance of the generator's raw water strainer, see *Generator Raw Water Strainer* later in this chapter.

! WARNING

Accidental starting can cause severe injury or death. Disconnect battery cables before working on generator. Disconnect negative, (-) cable first and reconnect it last when replacing.

NOTICE

If electrical load has been operating at more than 70 percent or if ambient temperature is higher than 77 degrees, stabilize generator temperature by turning off AC distribution panel breakers and letting generator run for a minimum of five minutes before shutting down.

DC Distribution Panel

Figure 3.33.1

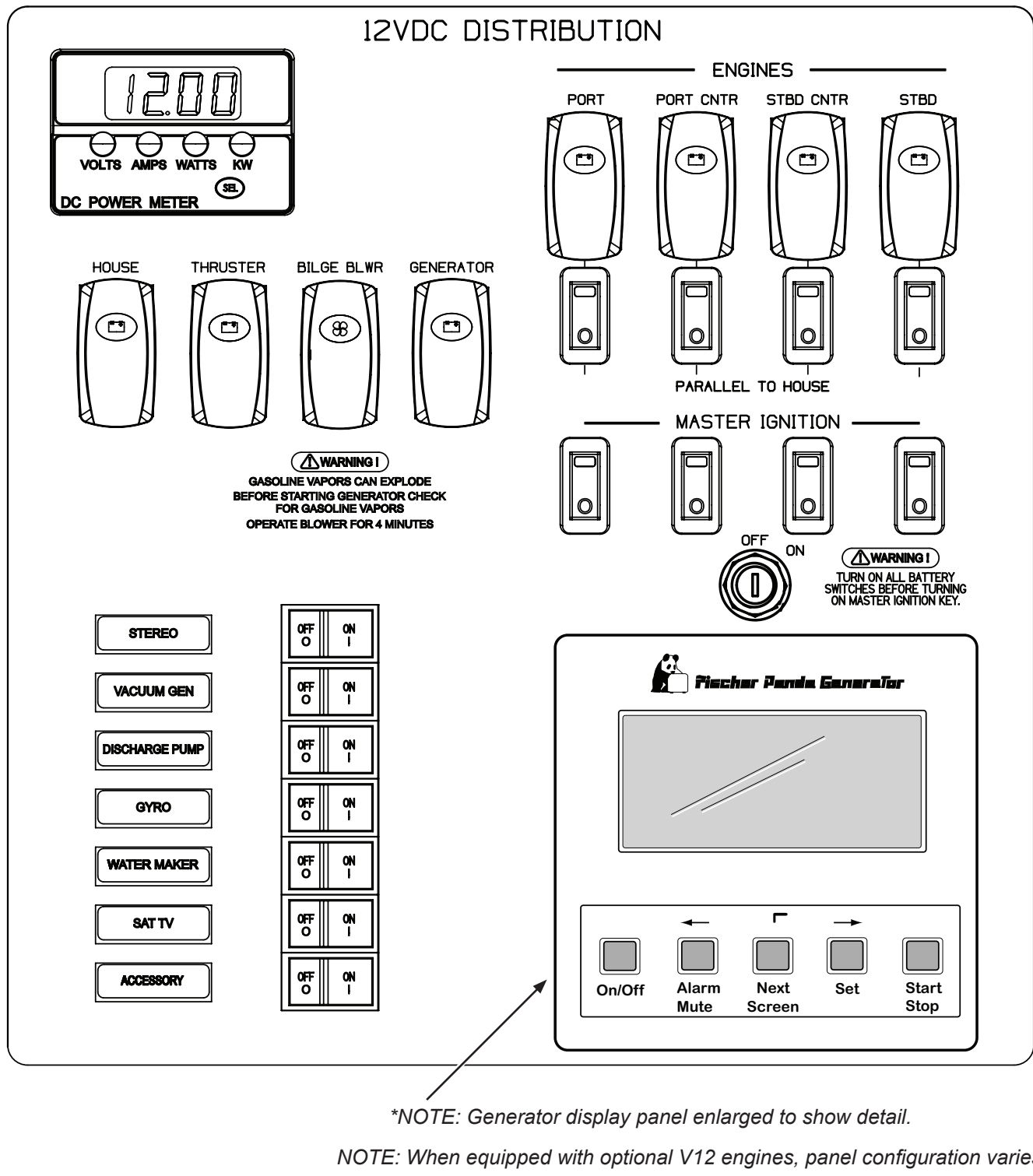

AC Main Distribution Panel
Figure 3.34.1

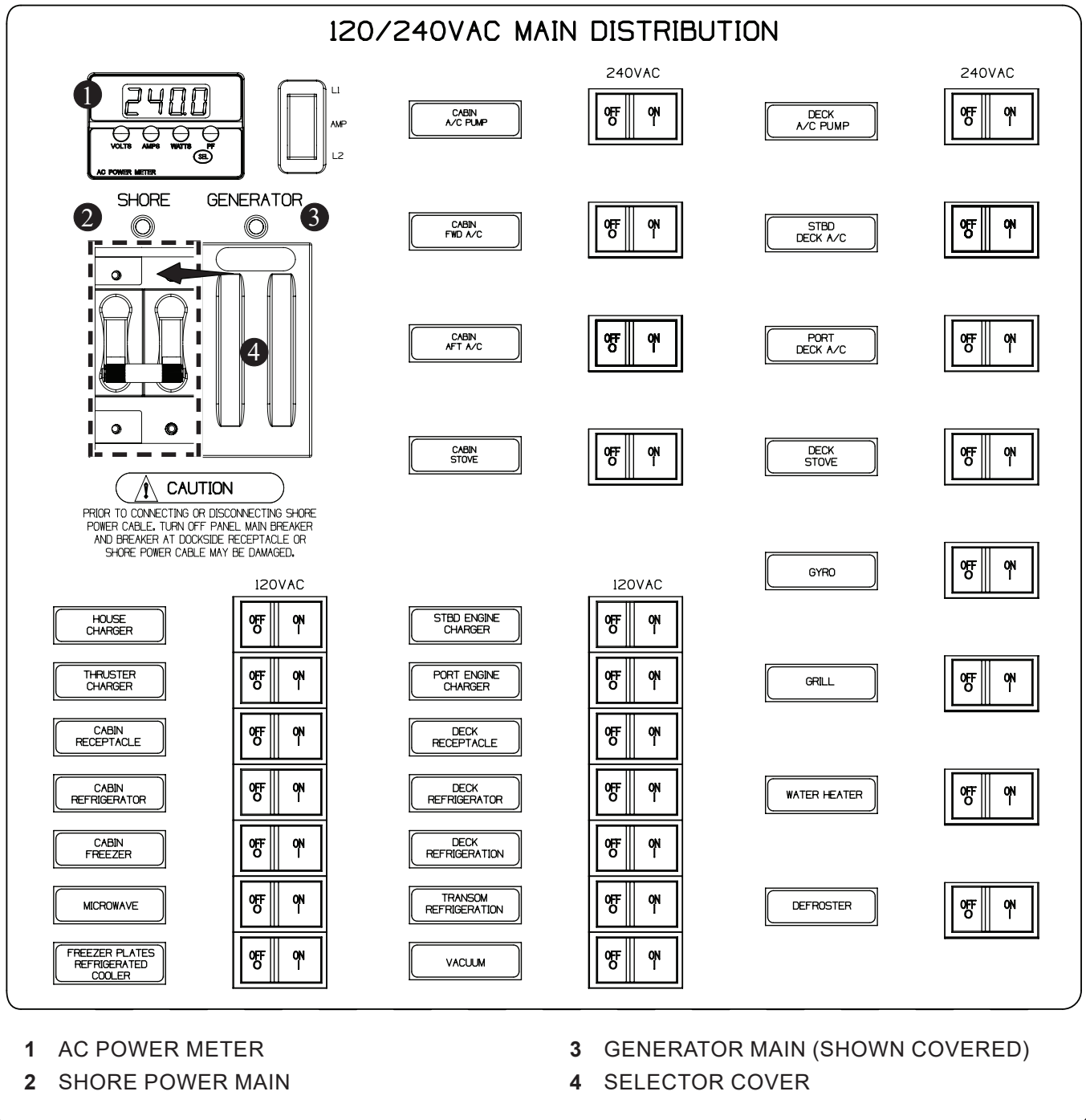

Generator Shutdown

1. Turn off AC main distribution panel breakers (see Figure 3.34.1); turn off *GENERATOR* breaker.
2. To stop generator, press *Start/Stop* button on generator display panel (see Figure 3.33.1).
3. Press *On/Off* button to deactivate generator panel (see Figure 3.33.1).
4. Turn off *GENERATOR* switch.
5. Close generator's raw water seacock.

REFER TO OWNER'S PACKET FOR COMPLETE INSTRUCTIONS AND WARRANTY INFORMATION.

NOTICE

Initial maintenance, done by a qualified technician, is required on generator at 35 hours; maintenance checklist must be completed. Failure to comply invalidates warranty.

Generator Fuel Filter, Pump, Pre-filter

Generator fuel filter, pump, and pre-filter (see Figure 3.35.1) are located in the aft mechanical access hatch. A common cause of poor starting or power loss is the result of a clogged filter or a fuel system air leak.

Replacing Filters

Replace the filter according to the manufacturer's recommendations or if a power loss is detected.

REFER TO OWNER'S PACKET FOR COMPLETE INSTRUCTIONS AND WARRANTY INFORMATION.

Generator Filters
Figure 3.35.1

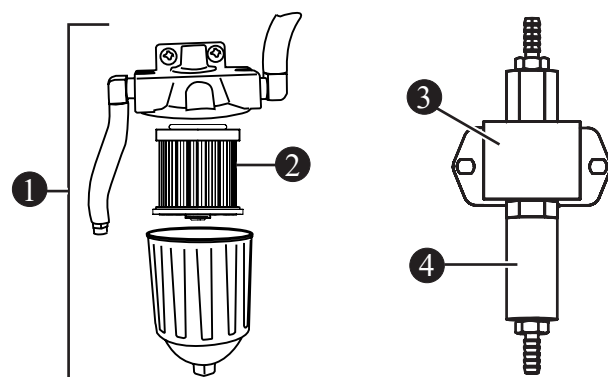

- | | |
|------------------------|--------------|
| 1 FUEL FILTER ASSEMBLY | 3 PUMP |
| 2 FUEL FILTER | 4 PRE-FILTER |

NOTICE

Carry spare filters onboard as contaminated fuel can easily clog a filter.

Generator Raw Water Strainer

The generator's raw water strainer (see Figure 3.35.2) helps filter raw water used in generator cooling. Periodically check the strainer for debris and clean as necessary. To inspect strainer:

1. Check to ensure generator is not running.
2. Using two-pronged spanner tool, mounted on the step in the aft mechanical access hatch, unscrew strainer cap.
3. Remove strainer and clean away debris.
4. Replace the strainer and secure cap.

Raw Water Strainer
Figure 3.35.2

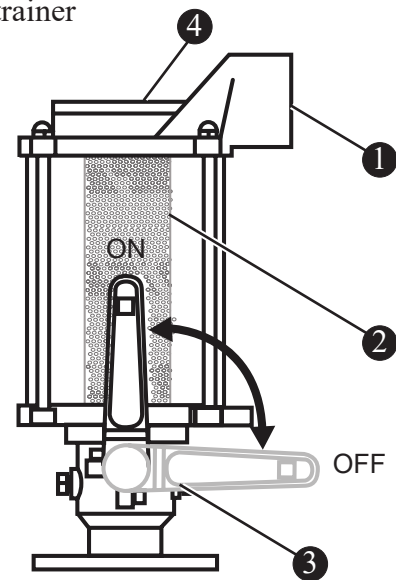

- | | |
|-----------------------|------------------|
| 1 OUTLET TO GENERATOR | 3 INTAKE SEACOCK |
| 2 STRAINER | 4 STRAINER CAP |

Generator Maintenance

Maintenance work must be performed by suitably trained maintenance personnel familiar with generator operation and service.

REFER TO OWNER'S PACKET FOR COMPLETE INSTRUCTIONS AND WARRANTY INFORMATION.

Operation in EU Member Countries

This generator is specifically intended and approved for below deck operation in the mechanical access hatch. Operation above deck and/or outdoors constitutes a violation of European Union Directive 2000/14/EC noise emission standard.

▲ DANGER

Never allow swimming when an AC electrical system is in use as it can lead to severe shock and/or death.

Shore Power

In addition to the primary DC electrical system, shore power can be used while docked to both energize the boat systems and charge the batteries. The boat

is connected to dockside power via a supplied 50 foot power cord. The shore power inlet is located at the transom (see Figure 3.36.1). Be sure to close the shore power cover after disconnecting the cord.

! CAUTION

- Shore power inlets must be dry before plugging into dockside power receptacle.
- Route and tie the power cord to dockside power box to prevent people tripping on it.
- Shore power cord should be routed or secured to prevent undue stress on plugs and inlet; do not allow submersion.
- Do not use extension cord as it can cause a voltage drop, preventing some electronic devices from operating correctly.

Shore Power Connections
Figure 3.36.1

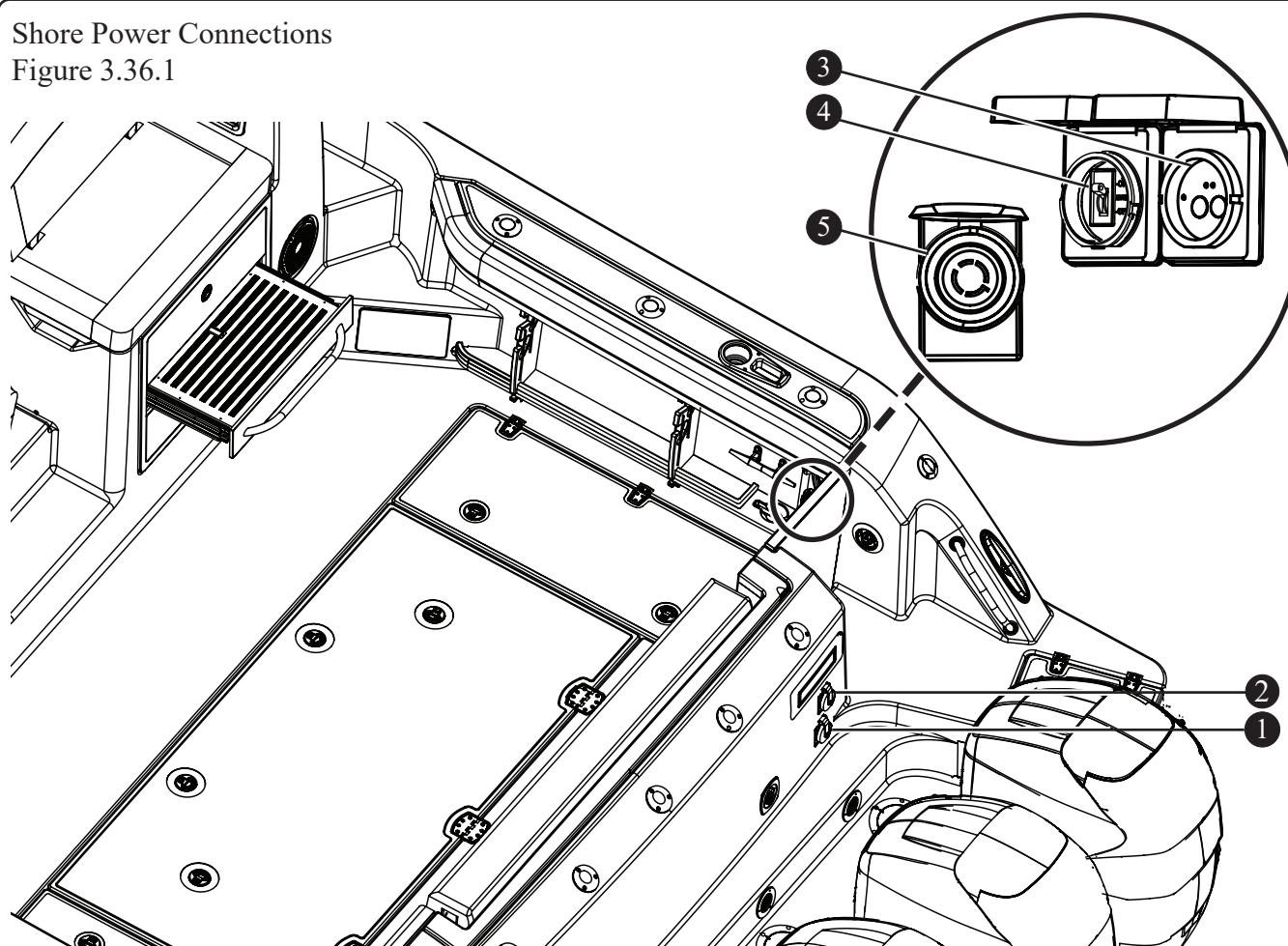

- 1 SHORE POWER INLET
- 2 CABLE TV INLET
- 3 EQUIPMENT LEAKAGE CIRCUIT INTERRUPTER

- 4 SHORE POWER INLET BREAKER
- 5 ELECTRIC REEL RECEPTACLE (OPTION)

Equipment Leakage Circuit Interrupter

DANGER

Receptacle will not protect against line-to-line or line-to-neutral faults, short circuits or overloads.

The shore power system on the boat includes an equipment leakage circuit interrupter located on starboard gunwale (see Figure 3.36.1). The equipment leakage circuit interrupter is designed to protect people from line-to-ground shock hazards which may occur from defective, misused or neglected electrical equipment. The circuit interrupter won't prevent line-to-ground electric shock, but does limit the time of exposure to a period considered safe for normal healthy persons. If an imbalance of current is sensed, the circuit interrupter will trip when the ground fault exceeds 0.030 amps. This tripping action will occur within a fraction of a second to prevent serious injury.

Testing and Troubleshooting

NOTE: Test before each use.

When operating normally, the sensing device illuminates green to indicate it is on and circuit breaker is in the on position. To test:

1. Press test button; green light turns off and red light illuminates. The circuit breaker flips off.
2. If sensing device or breaker does not trip or change state, do not use.
3. Press reset button; red light turns off and green light turns on.
4. Manually reset (switch) circuit breaker to on position to restore circuit power.

WARNING

If above tests fail, do not use. Consult a qualified electrician for repair or replacement.

Shore Power Operation

Before making shore power connections make sure this vessel is properly moored. Several key points of shore power operation are detailed here:

1. Slide *GENERATOR* selector cover to expose

the shore breaker (see Figure 3.38.1).

2. Ensure all AC main distribution panel breakers are switched off (see Figure 3.38.1).
3. Ensure shore power inlet breaker is off (see Figure 3.36.1).
4. Using shore power cord, connect female plug to shore power inlet.
5. Ensure dockside breaker is off; connect male plug.
6. Turn on dockside breaker and shore power inlet breaker.
7. Switch boat's *SHORE* power main on (see Figure 3.38.1).
8. On the AC main distribution panel's *AC POWER METER*, verify voltage is 240V.
9. Turn on AC main distribution panel breakers as needed (see Figure 3.38.1).

REFER TO OWNER'S PACKET FOR COMPLETE INSTRUCTIONS AND WARRANTY INFORMATION.

CAUTION

Check to ensure shore power main switch is turned off before connecting the power cord cordset. Connect cordset to boat inlet first, then to shore inlet. Never alter cordset connectors.

CAUTION

Extension power cord use is not recommended and can cause a voltage drop and prevent some electronics from operating properly.

CAUTION

Shore power outlet must be dry before plugging into the dock power outlet.

CAUTION

Shore power cords should be secured or routed to avoid laying or falling into water and to avoid stress on shore power plug and inlet.

AC Main Distribution Panel

Figure 3.38.1

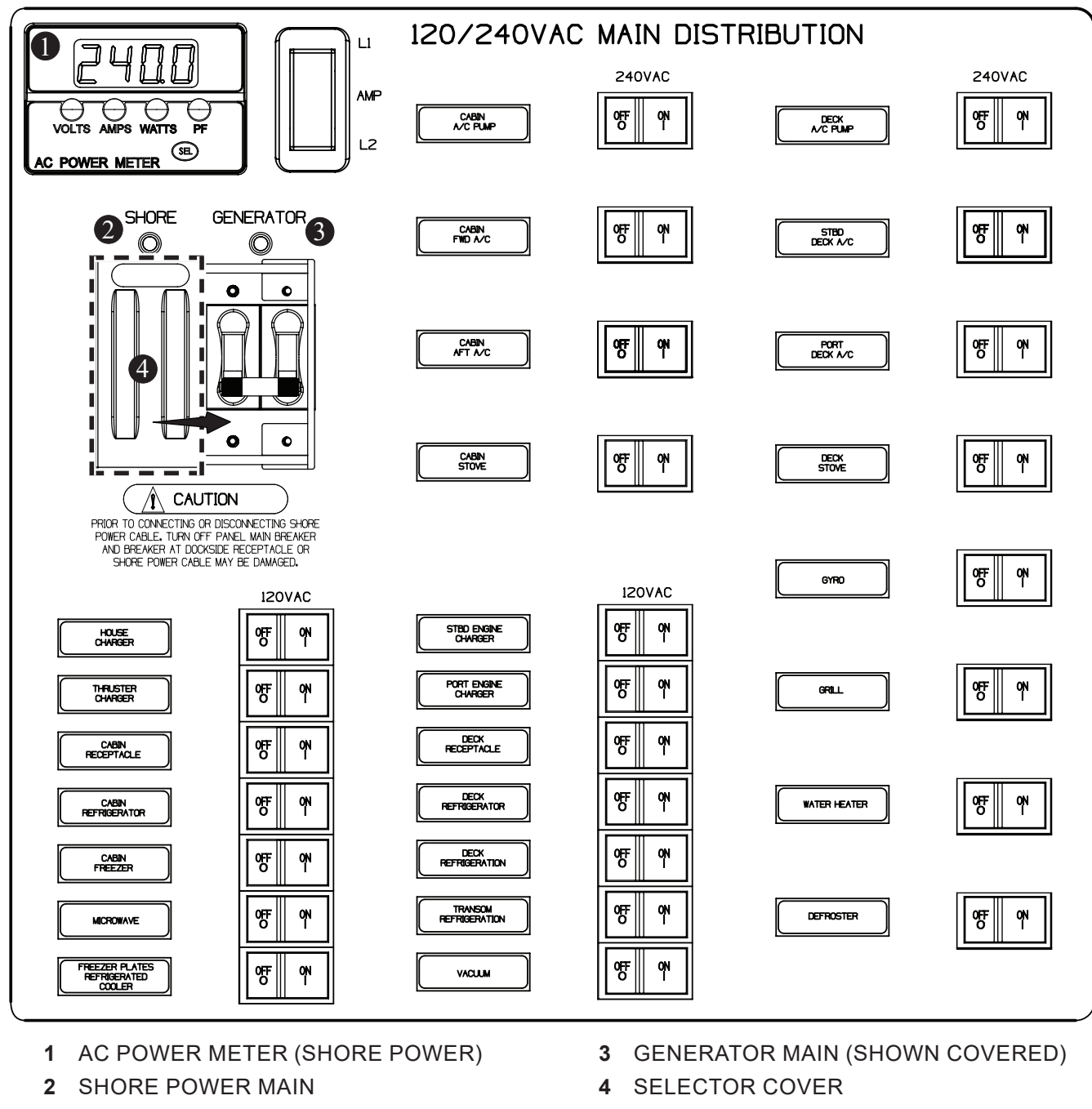

Battery Charging

In addition to supplying AC power to this vessel, shore power hookup offers the ability to charge batteries without running the engines. The system is automatic and little or no maintenance is required as long as the battery charger breaker is on.

The house battery charger bank is in the forward mechanical hatch and the engine battery chargers are in the aft mechanical access hatch.

Shore Power Load Management

This vessel is equipped with many devices that require AC power for operation. While many of these devices are continuous use items, others are not. The design of the electrical system has been optimized to support the most commonly used equipment.

Isolation Transformer

This vessel is equipped with isolation transformers which block low voltage DC on the shore power ground wire. Isolation transformers prevent dockside voltages from damaging metal parts which come in contact with the water. Additionally, isolation transformers safely conduct high currents (above 1.5 volts) to ground in the event of a short circuit or power leakage. Test transformers once per season, and re-tested after a condition that may have influenced them, such as a lightning strike in the vicinity, or on-board electrical short that either caused a circuit breaker or fuse to blow.

CAUTION

Under normal conditions this vessel's sacrificial anodes should last at least a year, much longer if no problems occur. If abnormal deterioration of the anodes occur a problem exists and should be corrected immediately.

Fire Suppression System

DANGER

Inhalation of high concentrates of fire suppression tank contents may cause sudden death without warning. If contact with skin occurs, flush area with water for at least 15 minutes. Seek immediate medical assistance.

REFER TO OWNER'S PACKET FOR COMPLETE INSTRUCTIONS AND WARRANTY INFORMATION.

This vessel is equipped with a USCG approved automatic fire suppression system installed with the diesel generator in the aft mechanical access hatch.

Each time the boat is powered up, the fire suppression system runs a test sequence, sounding the alarm and illuminating the indicator lights on the panel (see Figure 3.40.1) for one second. If there are no faults, only the green *POWER* indicator remains lit.

The system discharges when the temperature in the enclosed area reaches 165°F (74°C), triggering an explosive sound, (similar to a gun shot) followed by the sound of rushing air. This automatically shuts down the generator and the panel's red *DISCHARGE* indicator remains lit. If system discharge occurs:

- Shut down all electrical systems, engines, blowers, and extinguish all smoking materials.
- Allow the agent to soak the compartment for at least 15 minutes.
- Do not open the mechanical access hatch.
- Do not breathe the fumes or vapors caused by fire as they are hazardous and toxic.
- When opening the hatch, have a portable fire extinguisher at hand and ready for use.
- High concentrations of the agent may cause death without warning. The vapor reduces available oxygen for breathing.
- If possible, allow compartment vapors to dissipate before opening the hatch.
- Silence the alarm by pressing *SHUTDOWN RESET* button (see Figure 3.40.1).
- Before reenergizing equipment or starting generator, determine cause of alarm and, if needed, correct issue.

DANGER

Do not handle the actuator. The fire suppression system is under pressure (195 PSI). Accidental discharge may result in death or serious injury.

Fire Suppression Panel
Figure 3.40.1

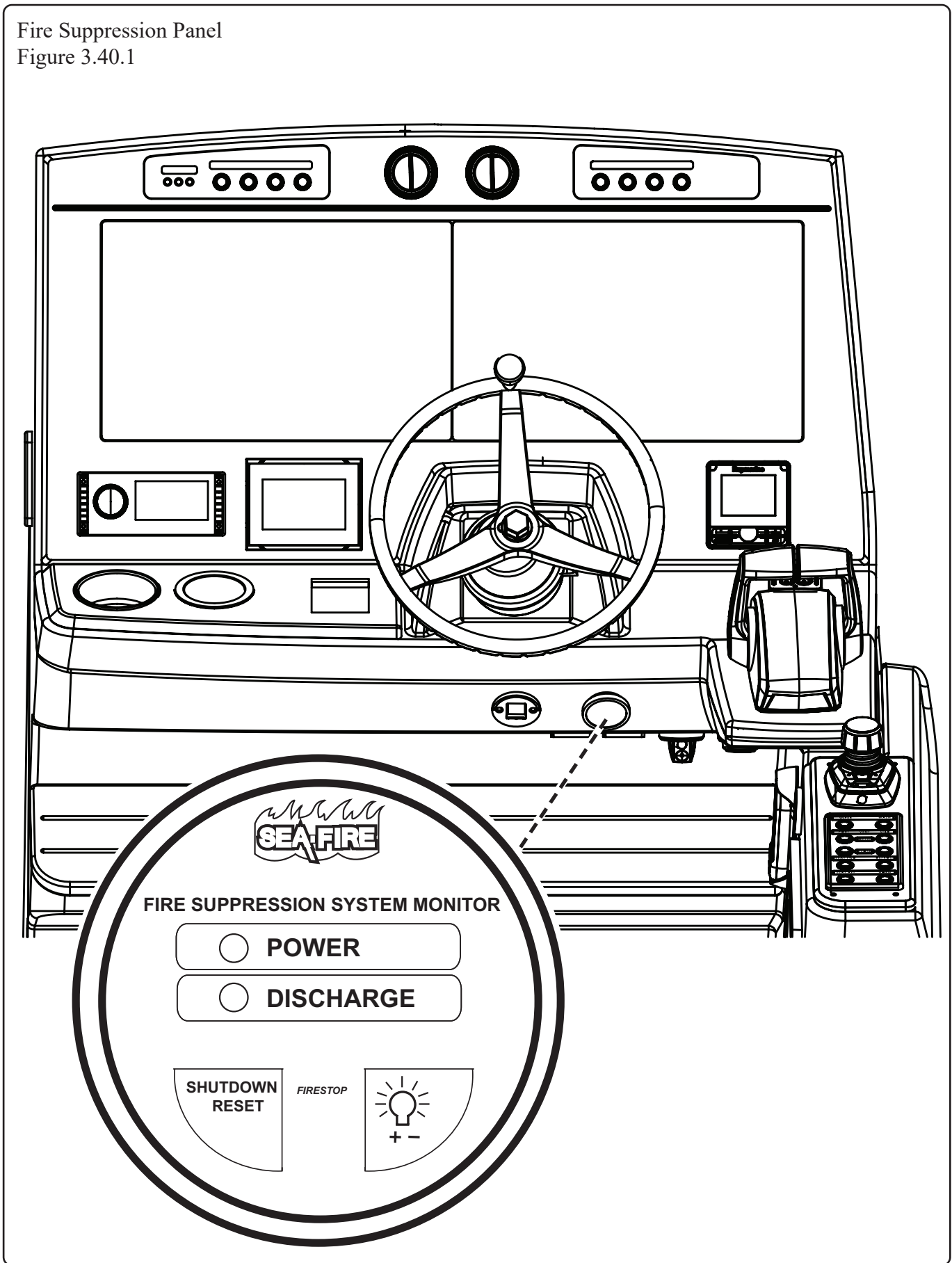

Manual Fire Override System

The manual fire extinguisher is activated manually by pulling the manual release handle located below the companion seat (see Figure 3.41.1 and Figure 3.41.2).

Early fire detection and use of the manual override system reduces fire damage by eliminating the time necessary for heat in the bilge to rise sufficiently to activate the automatic system. To operate:

1. Pull pin securing the handle (see Figure 3.41.2).
2. Pull red *FIRE* release handle out briskly.

For additional information on the system, see *Fire Suppression System* earlier in this chapter.

CAUTION

Never attempt to modify or disassemble any components of this system. If system discharge occurs, have a qualified technician replace it.

Fire Suppression System (Option)

Figure 3.41.2

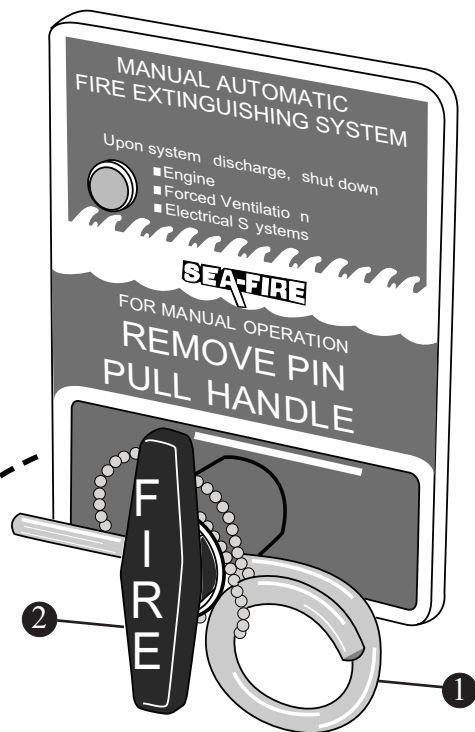

- 1 PIN
- 2 FIRE RELEASE HANDLE

Fire Suppression System

Figure 3.41.1

*NOTE: Companion seat shown in reverse position.

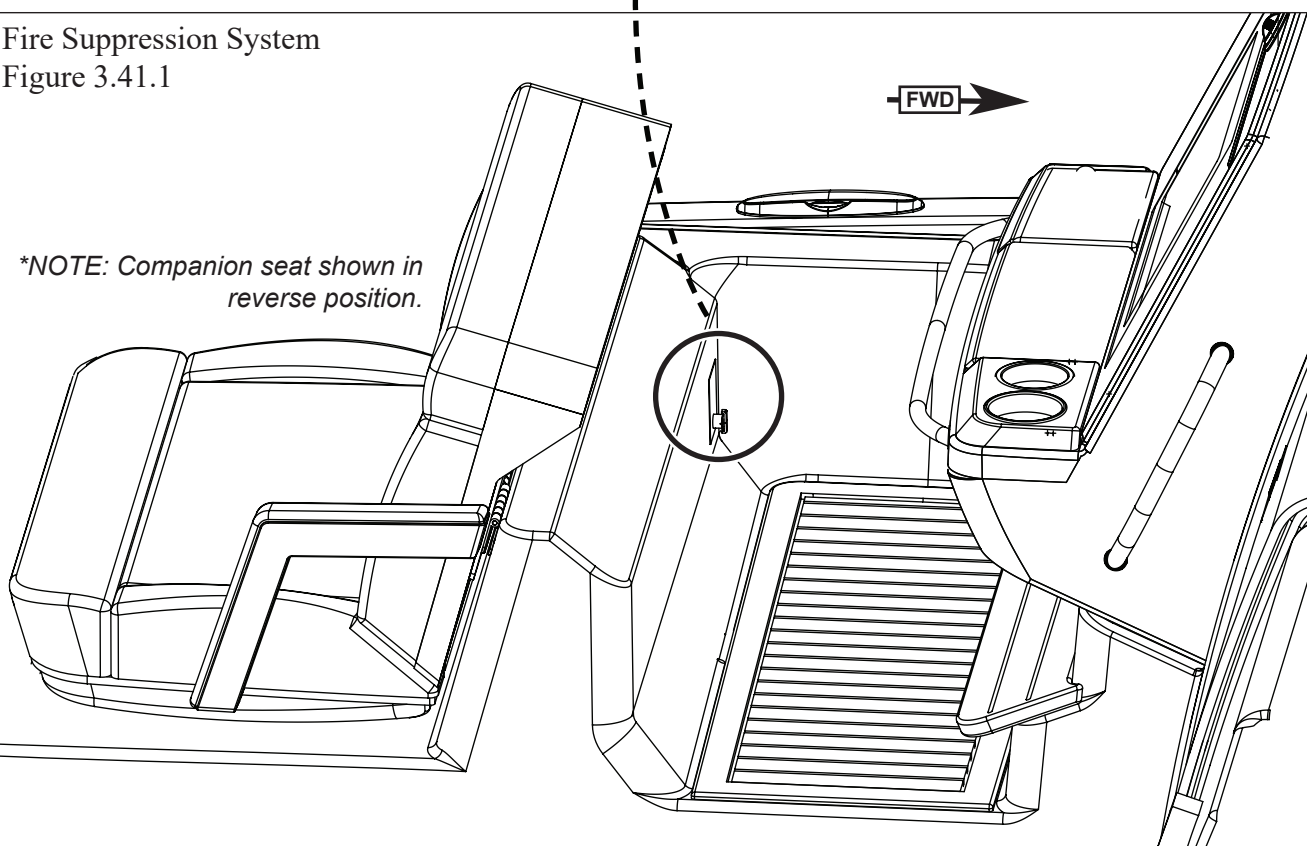

Dive Door and Ladder

⚠ DANGER

Ensure that door is closed and securely latched when boat is underway.

⚠ DANGER

To avoid risk of injury or death, shut off engines when using dive door to enter or exit water. Never deploy dive ladder when boat is in motion.

This vessel includes a port side dive door. Use the swivel grab handle for assistance when entering or exiting the water. To position grab handle, lift up and swivel into place. The dive ladder, which is stowed in the transom bench seat, is attached via the ladder bracket. To install dive ladder (see Figure 3.42.1):

1. Align ladder brace with ladder bracket slots.
2. Insert brace pegs into deck bracket.
3. Secure ladder into place by pushing brace outboard until it seats firmly into bracket and locking pin snaps into place.

Dive Door
Figure 3.42.1

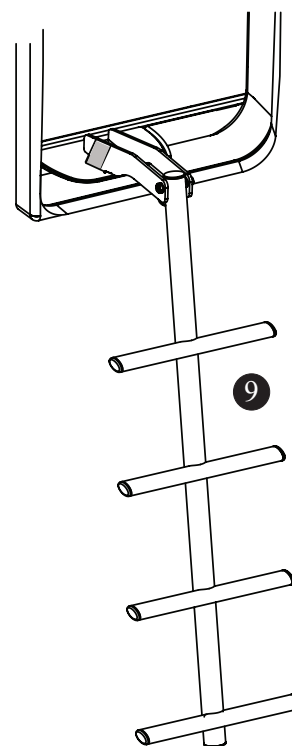
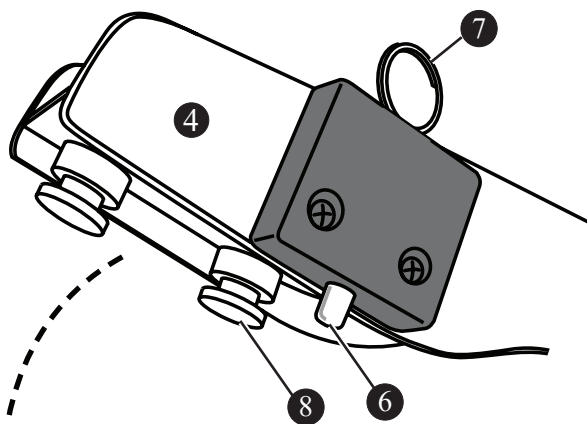
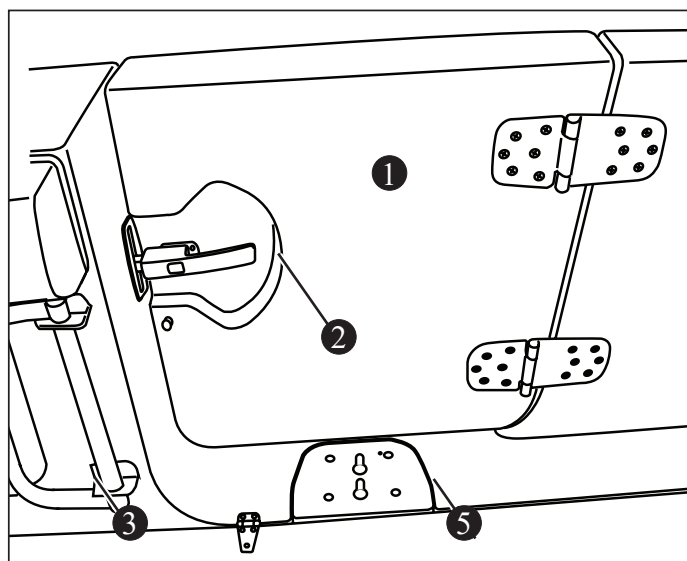

- 1 DIVE DOOR
- 2 DOOR LATCH
- 3 SWIVEL GRAB HANDLE
- 4 LADDER BRACE
- 5 LADDER BRACKET
- 6 LOCKING PIN
- 7 RELEASE RING
- 8 BRACE PEG
- 9 DIVE LADDER

To remove dive ladder from ladder brace (see Figure 3.42.1):

1. Pull and hold the release ring.
2. Pull dive ladder bracket inboard and lift up out of deck bracket.
3. Secure ladder in place on transom bench seat.

NOTICE

Always use bungee straps to secure the dive ladder in the aft bench seat brackets.

Transom Door

The transom door on this vessel includes a manual latch with a self-locking feature (see Figure 2.43.1).

! WARNING

Close and secure transom door when engines are running and boat is underway.

Transom Door
Figure 3.43.1

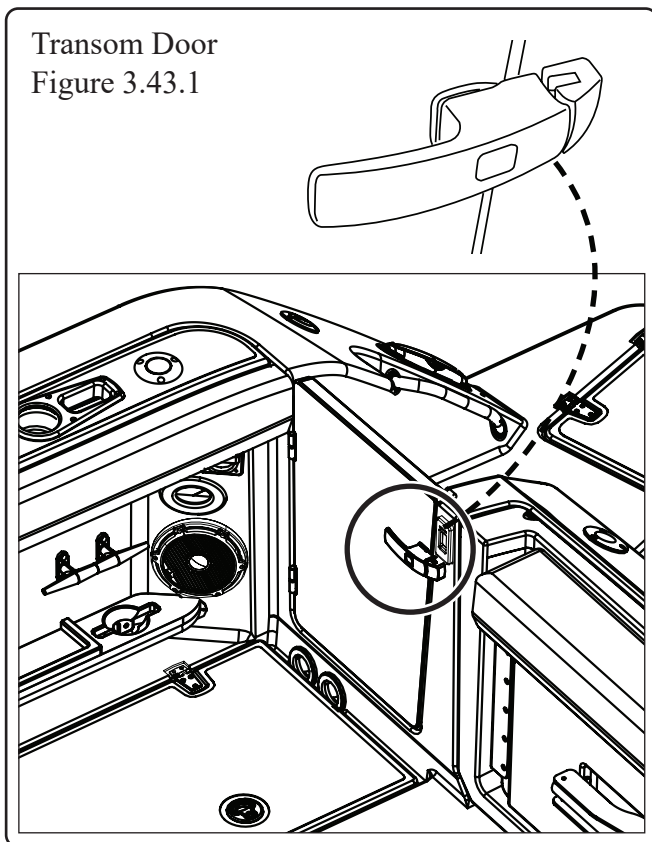

Fishbox with Pumpout Discharge

The two 72-gallon, deep-well fishboxes located port and starboard in the cockpit (see Figure 3.43.2) utilize a pump system for each box to discharge water overboard by way of thru-hull fittings port and starboard. The discharge pumps can be accessed through the aft mechanical access hatch. Clean out any obstructions that inhibit the pump from operating correctly.

The discharge pumps are independently activated by the *PORT F/B* and *STBD F/B* switches at the stern, below the livewell. These pumps are protected by breakers located on the main DC breaker panel. If the pumps fail to activate when the switches are depressed check the breakers first and reset if needed.

Fishboxes
Figure 3.43.2

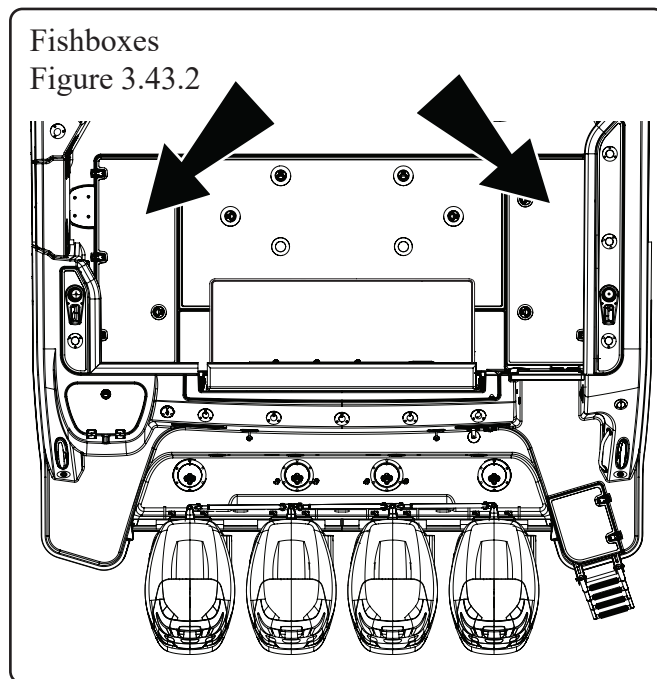

Refrigeration

The dual voltage 12V/120V refrigerator is located in the cockpit prep station (behind helm seat). The refrigerator has a 2.3 cu ft capacity and is powered by either shore power, if connected, or by the generator (option). The *REFRIG* breaker on the 120V AC breaker panel on the main distribution panel located in the cabin must be on for the refrigerator to function when using shore power or when generator is not in use. If not connected to shore power or the generator, the refrigerator/freezer is powered by the house batteries. If equipped, the 220 quart refrigerated cockpit chiller is located under the aft port seating (see Figure 3.44.1) and can be powered by either shore power or the generator.

NOTICE

To avoid draining the batteries, the refrigerator and/or battery switch must be turned off.

Refrigerated Chiller (Option)

Figure 3.44.1

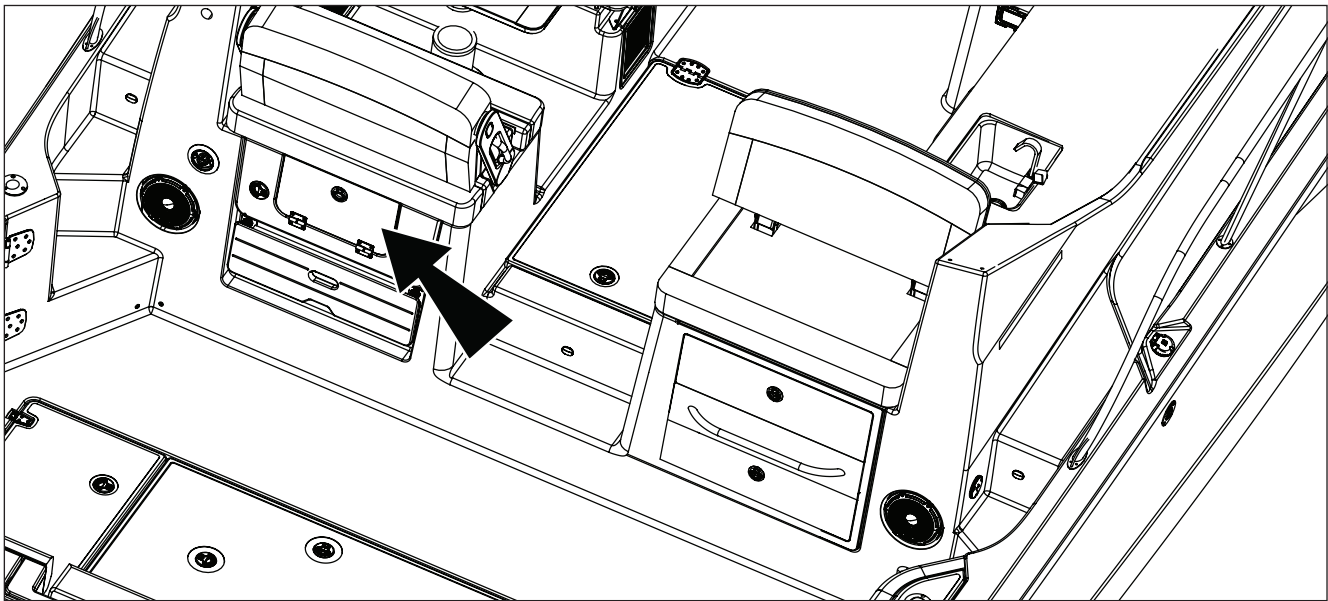

Freezer (Option)

If equipped, a top-loading freezer is located in the salon, built into the starboard seat with under cushion access (see Figure 2.44.2).

REFER TO OWNER'S PACKET FOR COMPLETE INSTRUCTIONS AND WARRANTY INFORMATION.

Freezer

Figure 3.44.2

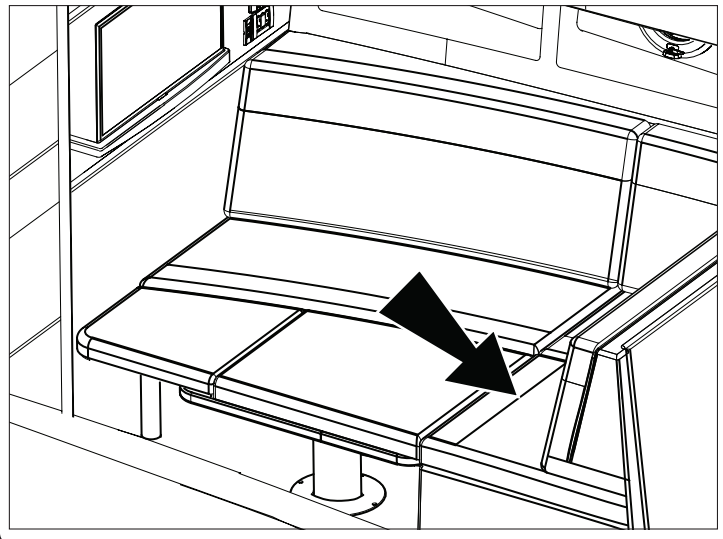

Chiller/Freezer Plate System (Option)

If equipped, the refrigerated chiller/freezer plate system (see Figure 3.45.1) transforms the fishboxes and the rear-facing cockpit cooler into refrigerated units. The system utilizes the A/C intake seacock to provide the raw water necessary for the unit to function. Water is discharged via a thru hull fitting. Refrigeration temperatures can be regulated from the main helm display and the refrigeration display located in the cabin.

NOTE: The main AC distribution panel's *DECK A/C PUMP* breaker must be on to operate the chiller system.

- 1 COMPRESSOR
- 2 COCKPIT CHILLER
- 3 PORT FISHBOX CHILLER
- 4 STARBOARD FISHBOX CHILLER
- 5 CHILLER SYSTEM DISPLAY (OPTION)
- 6 GYROSCOPIC STABILIZER DISPLAY
- 7 DOORWAY TO DECK
- 8 AC & DC DISTRIBUTION PANELS

Chiller/Freezer Plate System
Figure 3.45.1

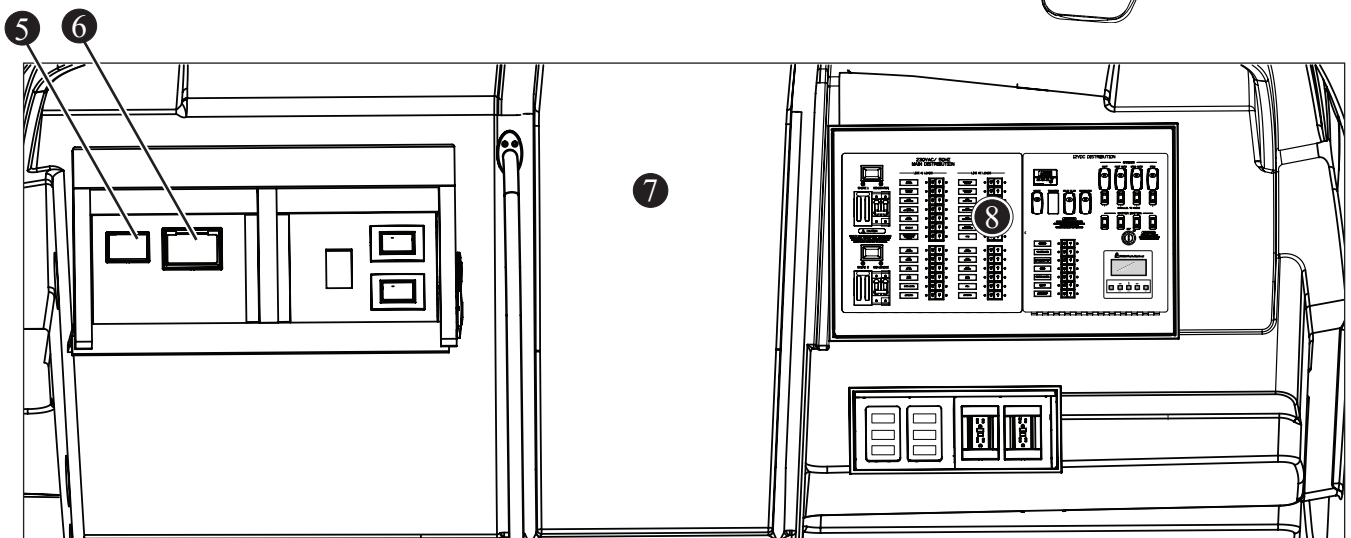
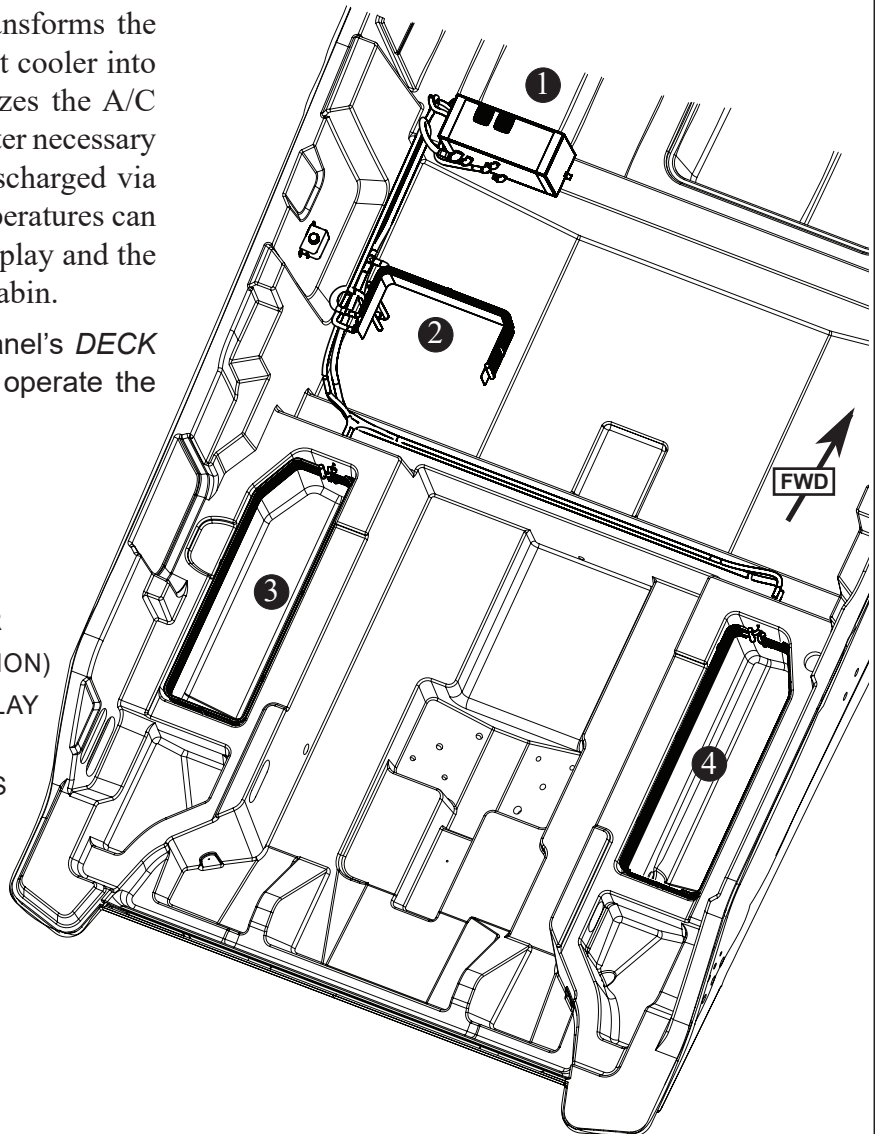

NOTE: View shown faces aft.

Electric Reel/Downrigger Receptacle (Option)

If equipped, the two 12V electrical receptacles for powering electric downriggers or any electrical equipment aptly rated, are located inside the cockpit on the aft section of the port and starboard gunwales (see Figure 3.46.1). Receptacles are protected by a weatherproof cover and matching plugs are included in the owners packet when this option is selected. Push the plug into the receptacle and turn clockwise to secure the connection. Breakers for the port and starboard electrical receptacles are located in the main DC breaker panel. Hard wiring of a downrigger to this connection should be done by a qualified electrician. There are areas on the gunwales specifically suited to downrigger mounting. For more information on mounting locations, consult a Boston Whaler dealer. Also see the reinforcement locations diagram (chapter 5, *Care and Maintenance*). Downrigger weight holders, located below the receptacles, are used for storing downrigger weights when not in use.

REFER TO OWNER'S PACKET FOR COMPLETE INSTRUCTIONS AND WARRANTY INFORMATION.

Electric Reel/Downrigger Receptacle
Figure 3.46.1

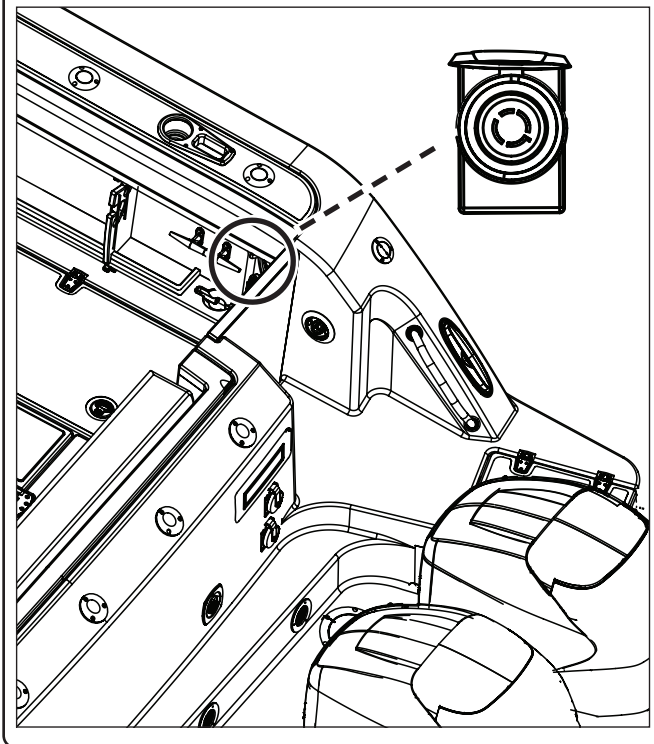

Fold-down Bench

When the transom bench is not in use it can be folded flush into the transom (see Figure 3.46.2). To use, lift the handle up and out toward you and push down.

Fold-down Bench
Figure 3.46.2

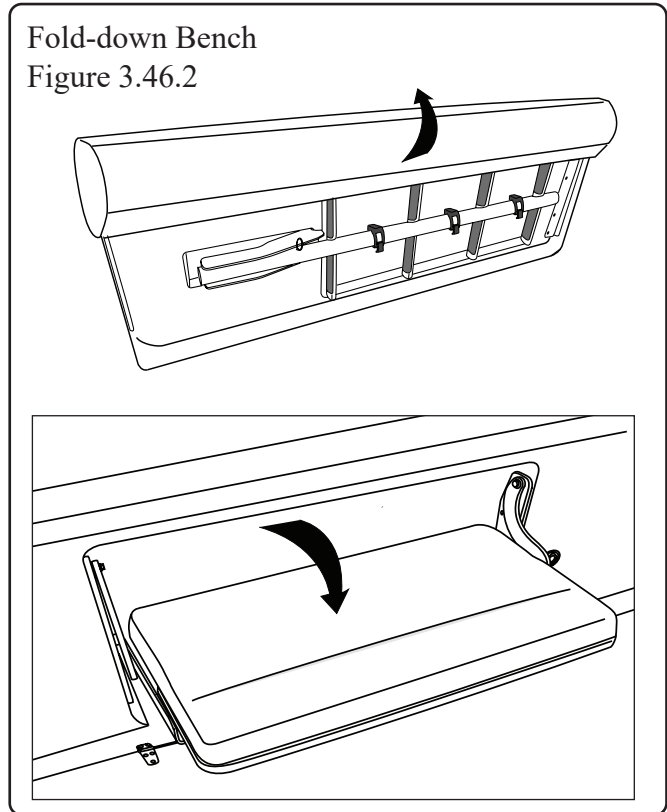

Cockpit Tables (Option)

The optional cockpit tables are stored on the underside of the aft mechanical access hatch (see Figure 3.47.1). Open the hatch and, while holding the table in place, swing the retaining hinges out of the way to release table. Remove support post and place it into the cockpit floor receptacle; place the table on top. Secure the table with the tightening handle. When not in use or while underway, stow the tables and posts back in the stored position.

Cockpit Table Set-up

Figure 3.47.1

- 1 AFT MECHANICAL ACCESS HATCH
- 2 COCKPIT TABLE (2)
- 3 SUPPORT POST (2)
- 4 RETAINING HINGE (2)
- 5 COCKPIT FLOOR RECEPTACLE

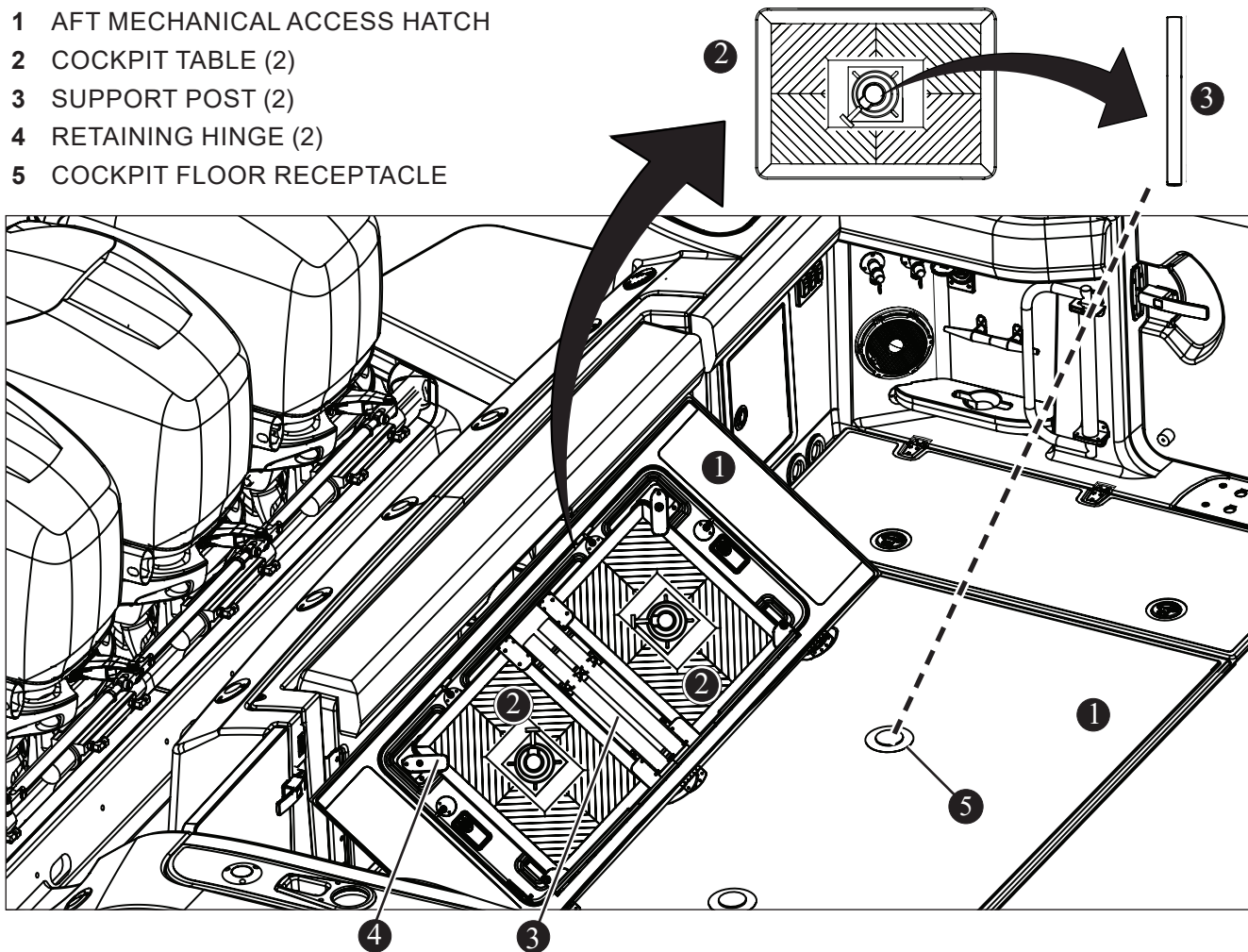

NOTE: Aft mechanical access hatch is shown simultaneously in both the open and closed positions.

Salon Bed

The cabin's salon table can be converted into a two-person bed (see Figure 3.48.1) To set up:

1. Using salon table switch (next to steps), lower salon table to lowest position.
2. Retrieve support post from under bench cushion; screw post into pedestal until audible clicks cease.
3. Retrieve bed cushions from mid-berth storage area and place onto table and pedestal as shown.
4. Locate, line-up, and attach snaps on bottom of table, pedestal, and under bench cushion.

Salon Bed Set-up
Figure 3.48.1

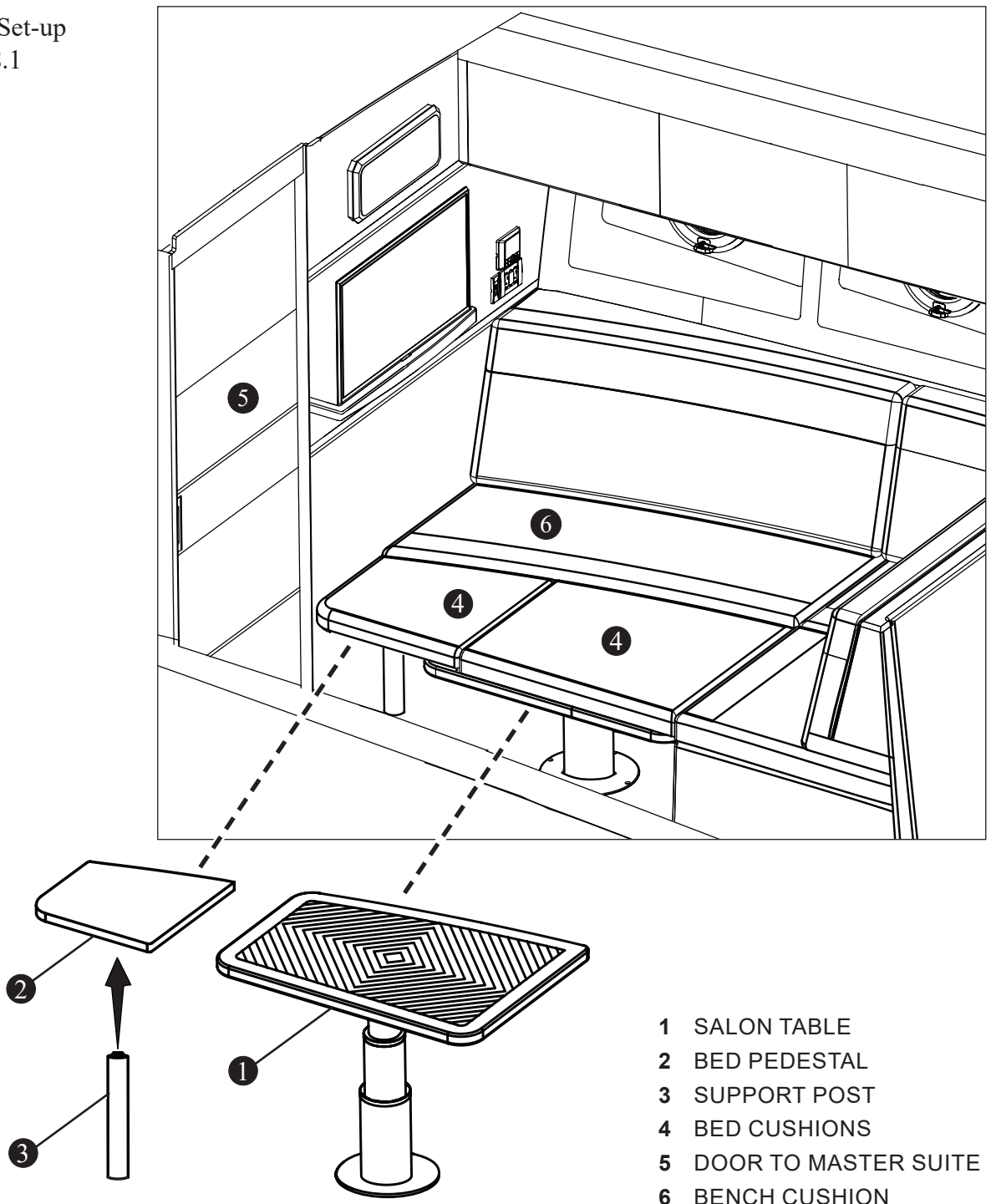

Convertible Lounge

The convertible lounge offers multiple set-up configurations as shown in Figure 3.49.1 through Figure 3.51.2.

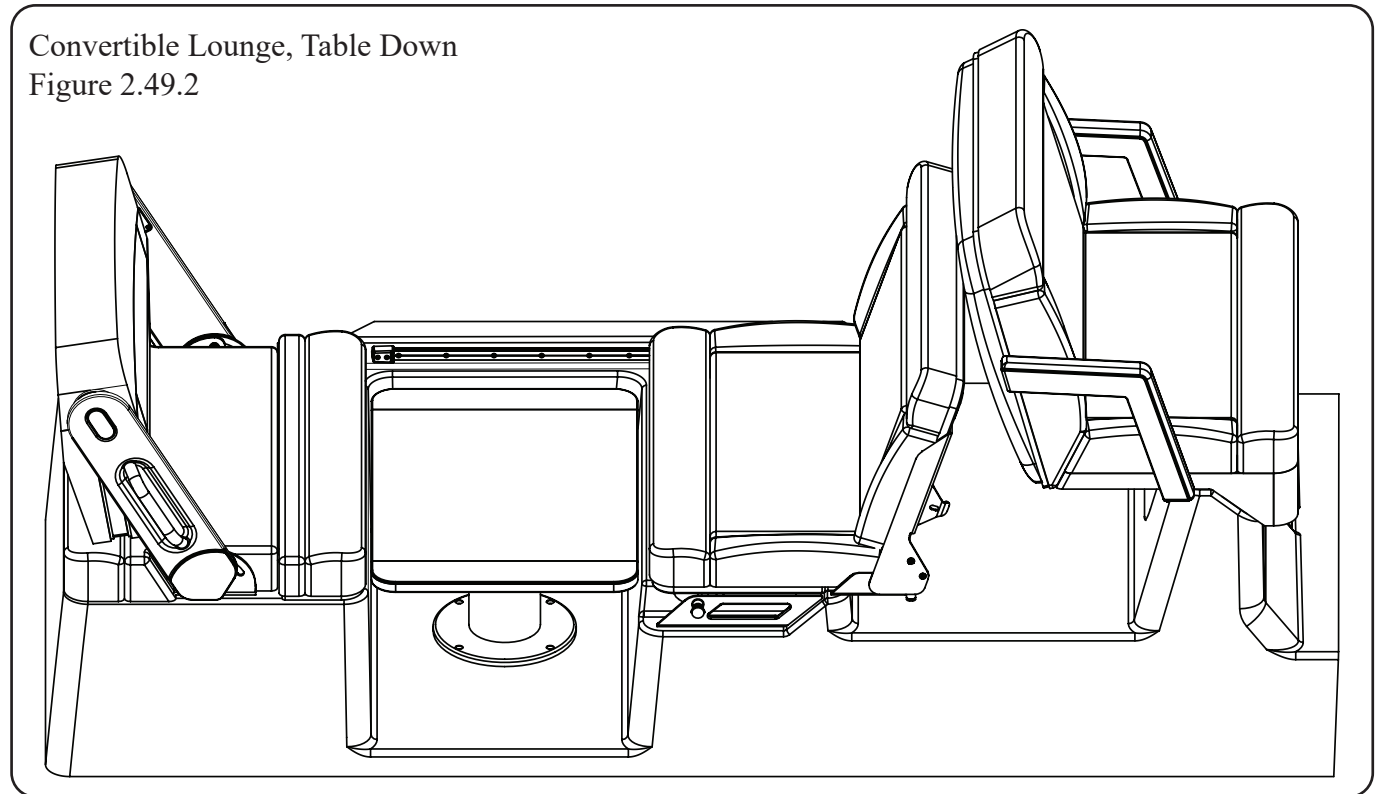
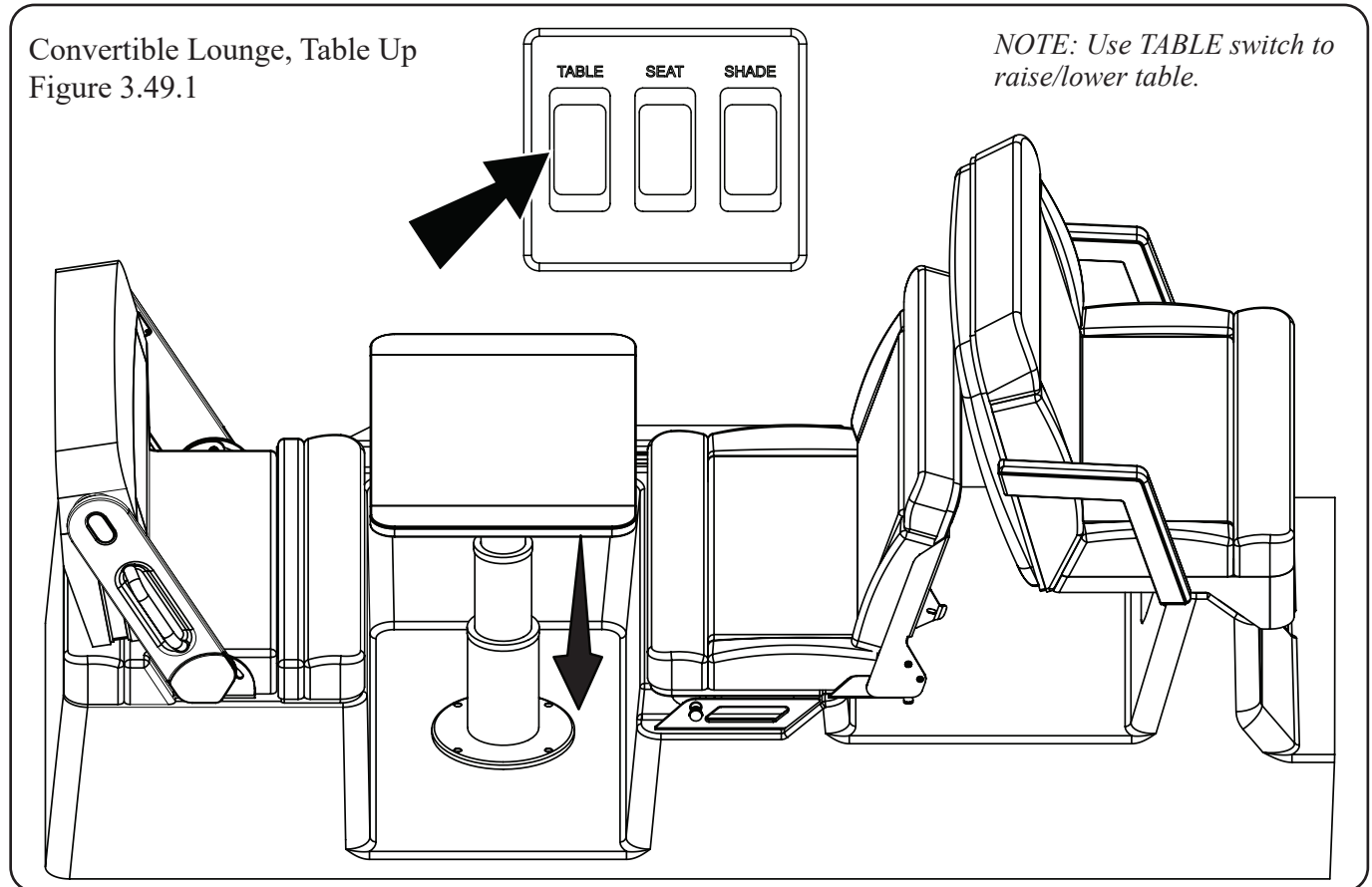

Convertible Lounge, Center Seat Left
Figure 3.50.1

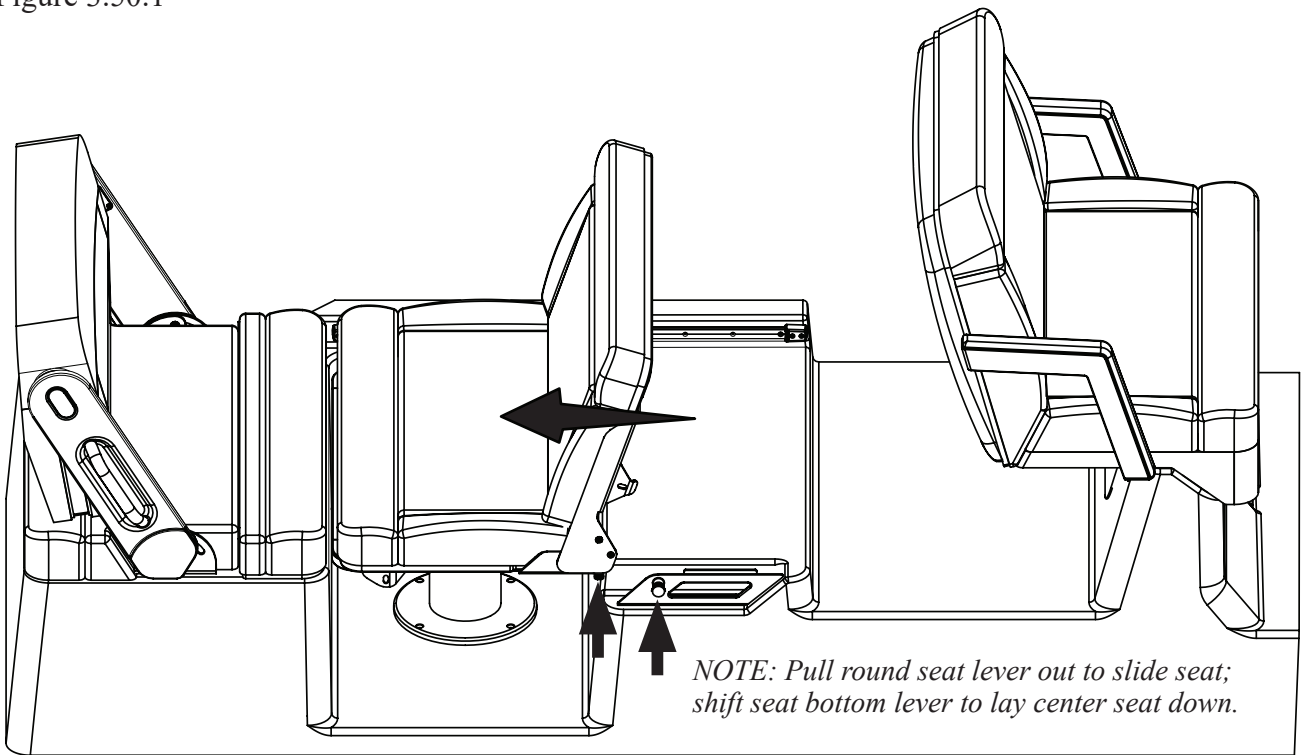

Convertible Lounge, Center Seat Down
Figure 3.50.2

NOTE: Use SEAT switch to flip powered seat.

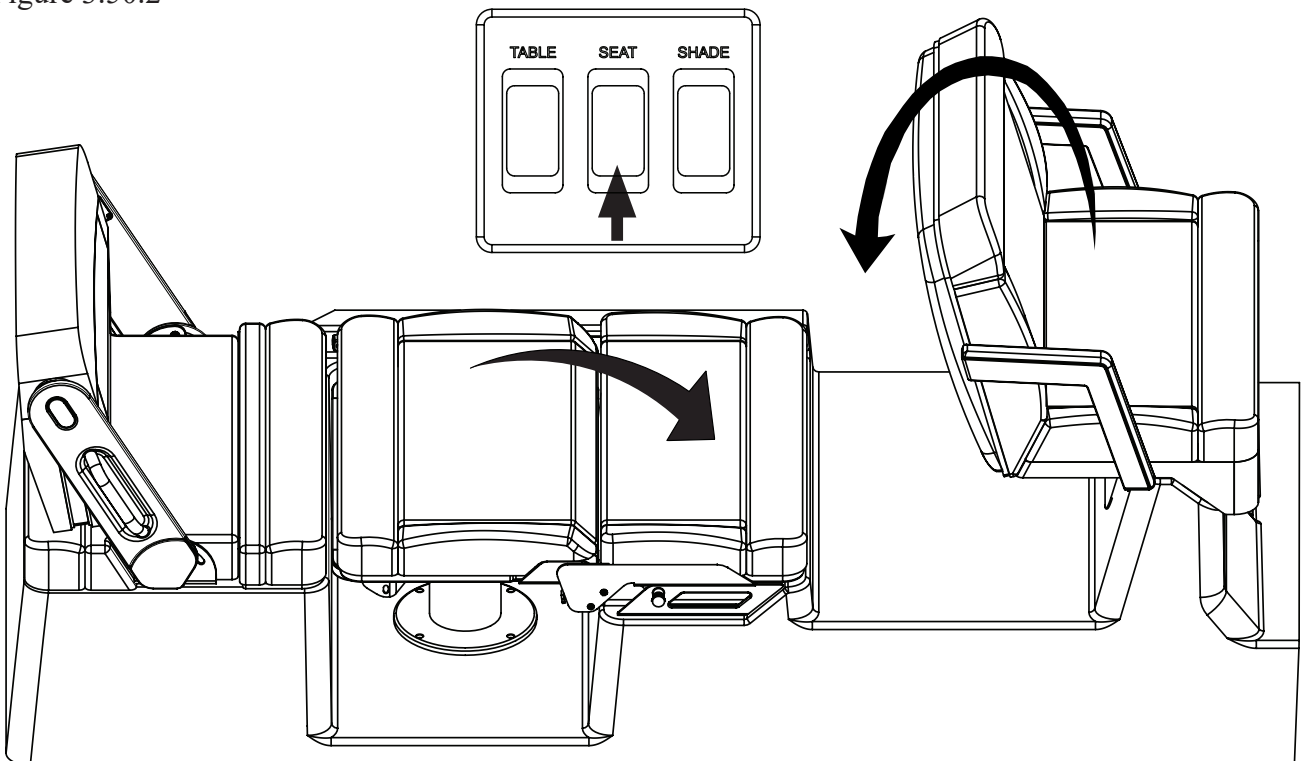

Convertible Lounge, Electric Seat Flipped
Figure 3.51.1

NOTE: Pull seat's grab handle to convert to rear-facing seat.

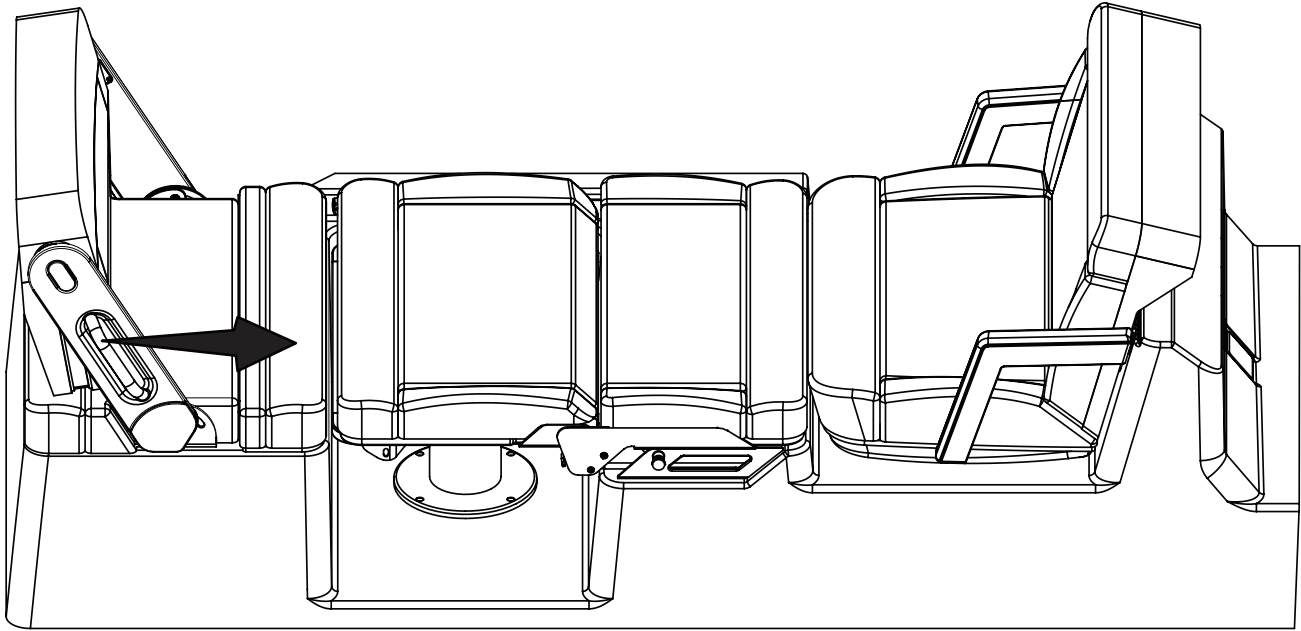

Convertible Lounge, Rear-facing Seat
Figure 3.51.2

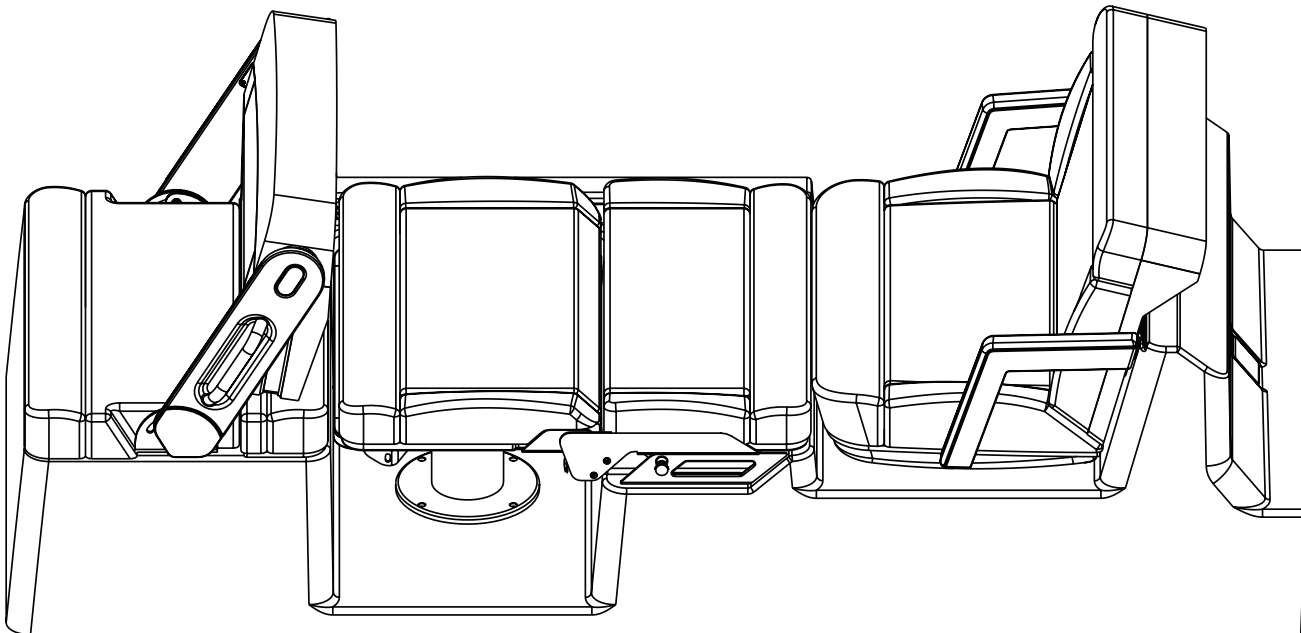

Pull-out Grill (see Figure 3.52.1)

This equipment affords onboard grilling. To operate:

1. Lift latch and pull handle to reveal grill
2. Lift grill lid to vertical position
3. Lower grill lid down until it seats firmly
4. Reverse process to close and store grill

Removable Grease Pan

NOTICE

To prevent grease pan from smoking, place one cup of water in the pan before cooking.

A reusable grease pan located under the heating element collects liquids associated with grilling. The grease pan must be emptied after each use. To remove grease pan:

1. Remove the grate.
2. Lift the heating element.
3. Remove the grease pan.

When replacing the pan, ensure it is completely contained within the grill and that the side of the pan does not extend outside of the grill.

Automatic Shut-Off

There is an automatic shut-off switch located at the back of the grill. When the cover is closed the shut-off switch is engaged and power to the grill is turned off. Do not under any circumstances override the automatic shut-off switch.

⚠ CAUTION

Electric Grill Becomes Dangerously Hot

Depending on level of heat used, the grill automatically shuts off 60 to 90 minutes after ignition. However, it is good practice to close lid when not in use. This action engages the automatic shut-off switch and cuts grill power.

REFER TO THE OWNER'S PACKET FOR COMPLETE INSTRUCTIONS AND WARRANTY INFORMATION.

Pull-out Grill
Figure 3.52.1

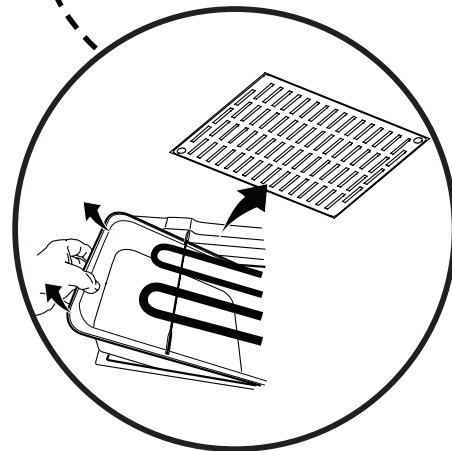
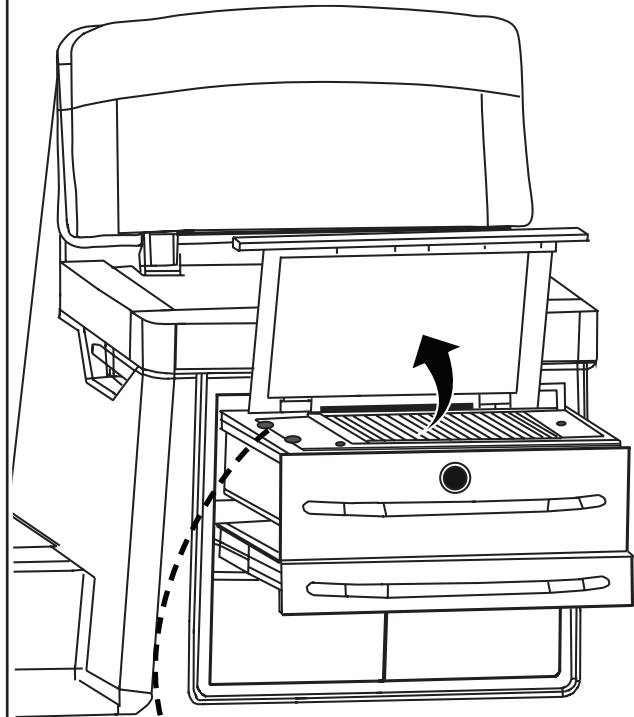

NOTICE

Keep grill closed while vessel is underway.

Cooktop

This vessel has an electric cooktop located in the galley. The cooktop is a single burner unit with touch controls. A series of lights indicate burner operation and hot surfaces. When lit, the *HOT* indicator light indicates that some portion of the surface is too hot to the touch. Before first time use, clean the cooktop with cook top cleaner. This provides a clean, shiny surface on the cooktop. Regular cleaning keeps the cooktop free from scratches and stains.

REFER TO OWNER'S PACKET FOR COMPLETE INSTRUCTIONS AND WARRANTY INFORMATION.

Cooktop Retaining Pins

The cooktop features a unique system which provides a barrier around the cooking surface to keep cookware from sliding off the surface and onto the counter or floor (see Figure 3.53.1). The pop-up pins on the cooktop are seated flush with the cooktop surface when not in use. To use, push and release each of four pop-up pins. When finished, press pins back down.

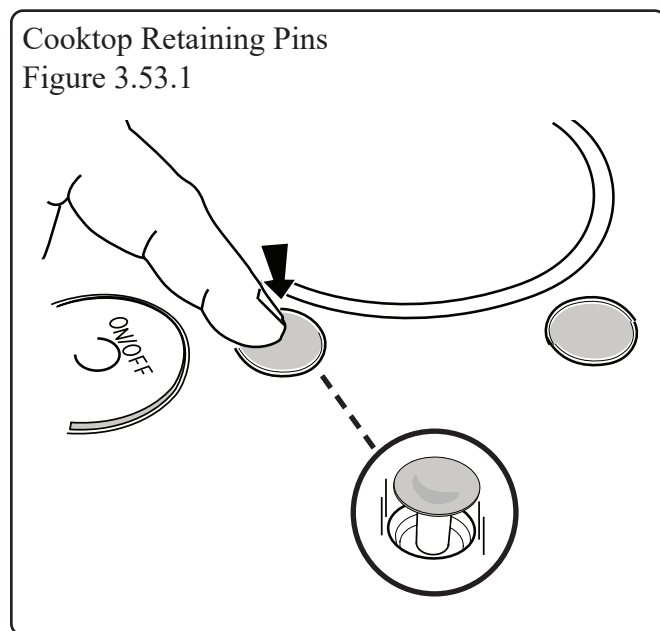

Entertainment System

Helm Deck

- Stereo control knob mounted in the dash.
- Stereo remote control on port lounge area that controls the stereo and volume at the helm.

Bow

- Stereo remote that controls the stereo and volume of the bow speakers.

Cockpit

- Stereo remote that controls the stereo and volume of the cockpit speakers

Salon

- Stereo unit with AUX in for TV audio integration, connected to cockpit sound system.
- TV

Stateroom

- Stereo with AUX in for TV audio integration
- TV

REFER TO OWNER'S PACKET FOR COMPLETE INSTRUCTIONS AND WARRANTY INFORMATION.

NOTICE

The generator must be on or shore power connected in order for the TV to operate.

NOTICE

WiFi connection and Apple iTunes account required for Apple TV operation.

CAUTION

Do not update any software without first contacting dealer or Boston Whaler. To do so will negatively impact digital switching access.

Outriggers (Option)

⚠ CAUTION

Always ensure clearance of bridges, lights, power lines, etc. while operating your vessel.

ATTENTION

Outriggers have an operable angle (up and down) of 65 degrees to 10 degrees. Keep this in mind when making adjustments.

If equipped, there are two radial outriggers mounted in the hardtop (see Figure 3.54.1). The outriggers offer adjustable to operation and store easily. Use the adjustment handle for raising, lowering, and rotating the outriggers. To raise/lower outriggers:

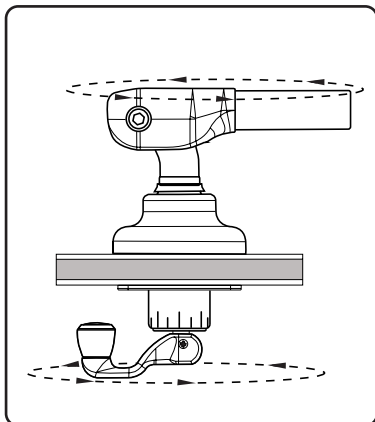
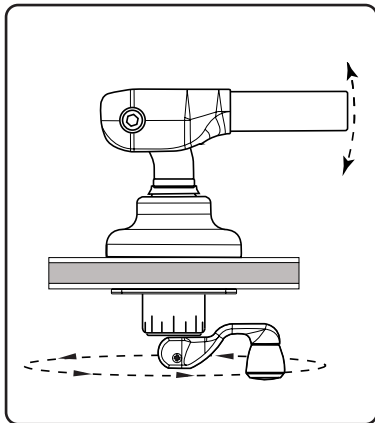

With the handle in the down position, rotate the handle clockwise to raise or lower the outrigger to the desired position.

To rotate outriggers in/out: Flip the handle to the up position. Grab firmly on the handle and rotate the handle to position the outrigger to the desired position. Keep the handle in the down position to keep the base from rotating while fishing and running.

Outrigger Base
Fig. 3.54.1

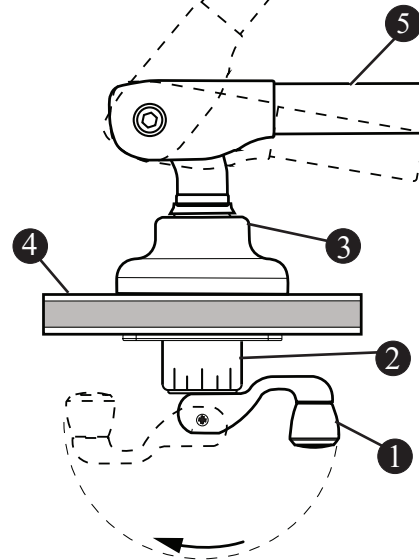

- | | |
|--------------|-------------|
| 1 HANDLE | 4 HARDTOP |
| 2 LOWER UNIT | 5 OUTRIGGER |
| 3 UPPER UNIT | |

Extending Outriggers

To extend the outriggers, loosen each section by hand, extend pole into place and retighten (see Figure 3.54.2).

REFER TO THE OWNER'S PACKET FOR COMPLETE INSTRUCTIONS AND WARRANTY INFORMATION.

Outrigger Extension
Fig. 3.54.2

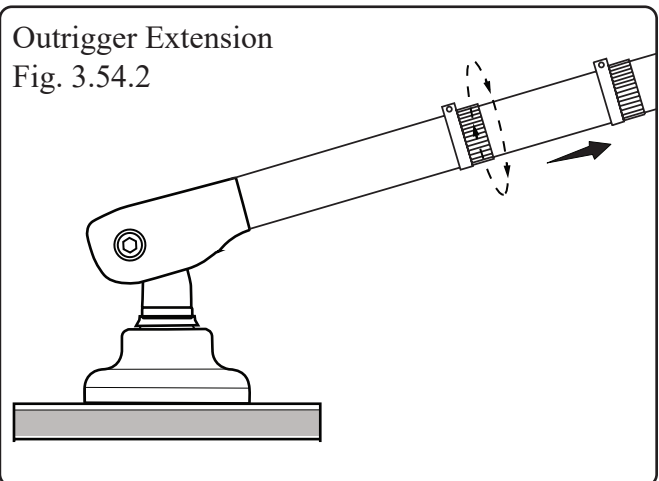

Spotlight

The spotlight is mounted forward on the hardtop and is controlled by a control pad located at the helm, which gives the operator a full 360 degree horizontal rotation and vertical tilt with fingertip control.



REFER TO THE OWNER'S PACKET FOR COMPLETE INSTRUCTIONS AND WARRANTY INFORMATION.

Thermal Night Vision Camera (Option)

If equipped, the fixed-mount, thermal night vision camera (see Figure 3.55.1) affords the operator night detection of floating objects, navigation aids, other vessels, and people in the water. The camera is controlled remotely from the helm display(s).

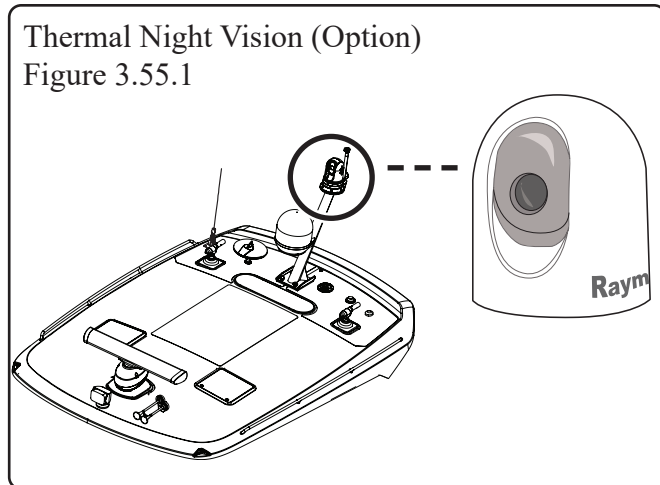

REFER TO OWNER'S PACKET FOR COMPLETE INSTRUCTIONS AND WARRANTY INFORMATION.

Windshield Vent

This vessel has two electrically-actuated windshield vents with independent *VENT* buttons located on the starboard switch panel. Depress and hold vent switches for the vent to open or close partly or completely.

Windshield Wipers

The windshield washer/wiper system is controlled by buttons labeled *WIPER* and *WASH* on the starboard switch panel. Access low, medium, and high wiper speeds by repeatedly pressing the *WIPER* button.

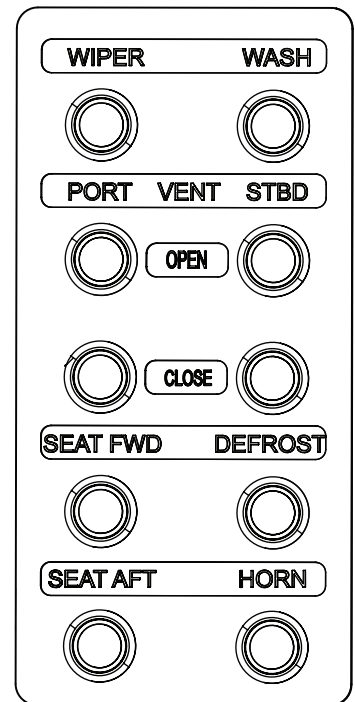

NOTICE

**Recommended blade replacement:
32" ANCO wiper blades**

Hardtop Skylight (Option)

The optional hardtop skylight (see Figure 3.56.1) is controlled by the *SKYLIGHT* switches in the hardtop. To operate, press *OPEN* button once and release to pop up skylight. Press *OPEN* a second time to open completely. Press *CLOSE* button to close completely.

Hardtop Skylight
Figure 3.56.1

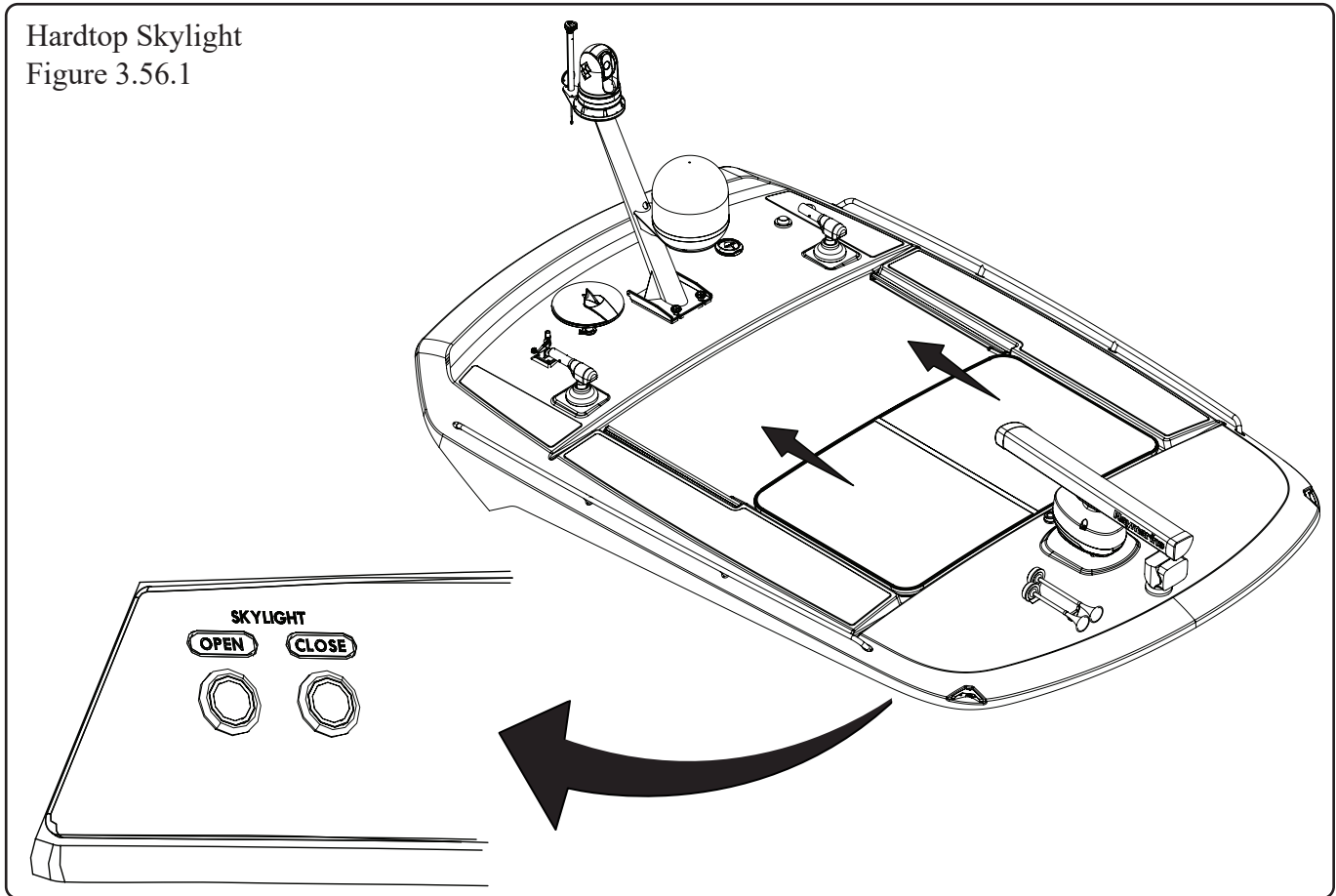

Electric Sun Shade

The electric sun shade can be deployed or retracted by depressing the *Shade* switch located at the cockpit prep station (see Figure 3.56.2). The sun shade is protected by a breaker located on the main DC breaker panel. Follow the canvas care instructions in chapter 5, *Care and Maintenance*.

WARNING

Electric sun shade is intended for use while boat is anchored or moored and not while underway. Damage to boat or personal injury could occur if shade is used while underway.

Electric Sun Shade
Figure 3.56.2

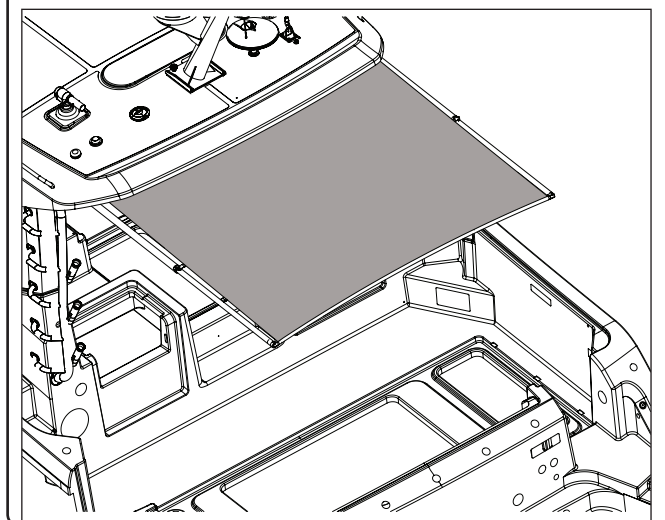

NOTICE

A reset functionality has been incorporated into the sun shade controller to enable a service technician to quickly reset the shade position. In the event the shade does not operate at either the fully extended or fully retracted position, contact a Boston Whaler dealer for details.

Bow Shade (option)

If equipped, the manually set up bow shade is constructed from four, two-piece poles (see Figure 3.57.1) and attaches to the hardtop. Follow the care instructions in chapter 5, *Care and Maintenance*.

Bow Shade
Figure 3.57.1

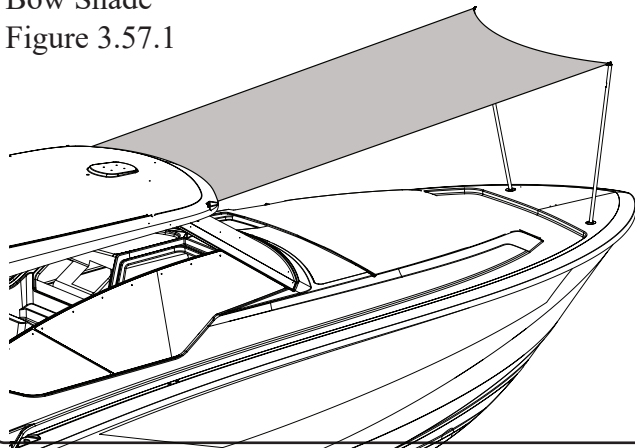

WARNING

Bow shade is intended for use while boat is anchored or moored and not while underway. Obstruction of navigation sidelights, damage to boat or personal injury could occur if shade is used while underway.

Lighting

Courtesy Lights

The multicolored courtesy lights located on this vessel can be controlled at the helm display. They can also be turned off and on via their designated switches on the boat.

Hardtop Lights

Hardtop lights include blue aesthetic lights, dual map lights (red and white), bow flood lights, and aft cockpit flood lights. These lights are controlled via the helm switch panel or the helm display.

CAUTION

Do not use hardtop accent lights when navigational lights are in use as this may interfere with navigational lights.

Underwater Lights (Option)

CAUTION

Do not use underwater lights when navigational lights are in use as this may interfere with effectiveness of navigational lights.

If equipped, there are six blue underwater lights. Four on the transom just below the surface of the water and two in the trim tab pockets on the bottom of the hull. When lit the lights illuminate the water in a translucent blue glow which enhances the after dark experience of being on the water and in addition may on occasion attract a myriad of marine life. Lights are controlled at the helm switch panel. Underwater lights turn off when navigation lights are turned on.

Mechanical Access Hatch Lights

There are four white lights in both the forward and aft mechanical access hatch areas. The lights in each turn on and off with the opening and closing of the respective hatch.

Accent Lights

Accent lights are activated automatically by photocells. This function can be manually turned off at the helm display.

Reboarding Ladder

The reboarding ladder is located under the reboarding ladder cover (see Figure 3.58.1). The ladder can be accessed without the cover raised. To deploy the reboarding ladder:

1. Release rubber locking strap.
2. Pull ladder out.
3. Release bungee cord and rotate ladder unit downward.
4. Extend ladder rungs.

Reboarding Ladder Deployment
Figure 3.58.1

- 1 REBOARDING LADDER COVER
- 2 SLIDING FRAME
- 3 REBOARDING LADDER RETRACTED
- 4 BUNGEE CORD
- 5 RUBBER LOCKING STRAP

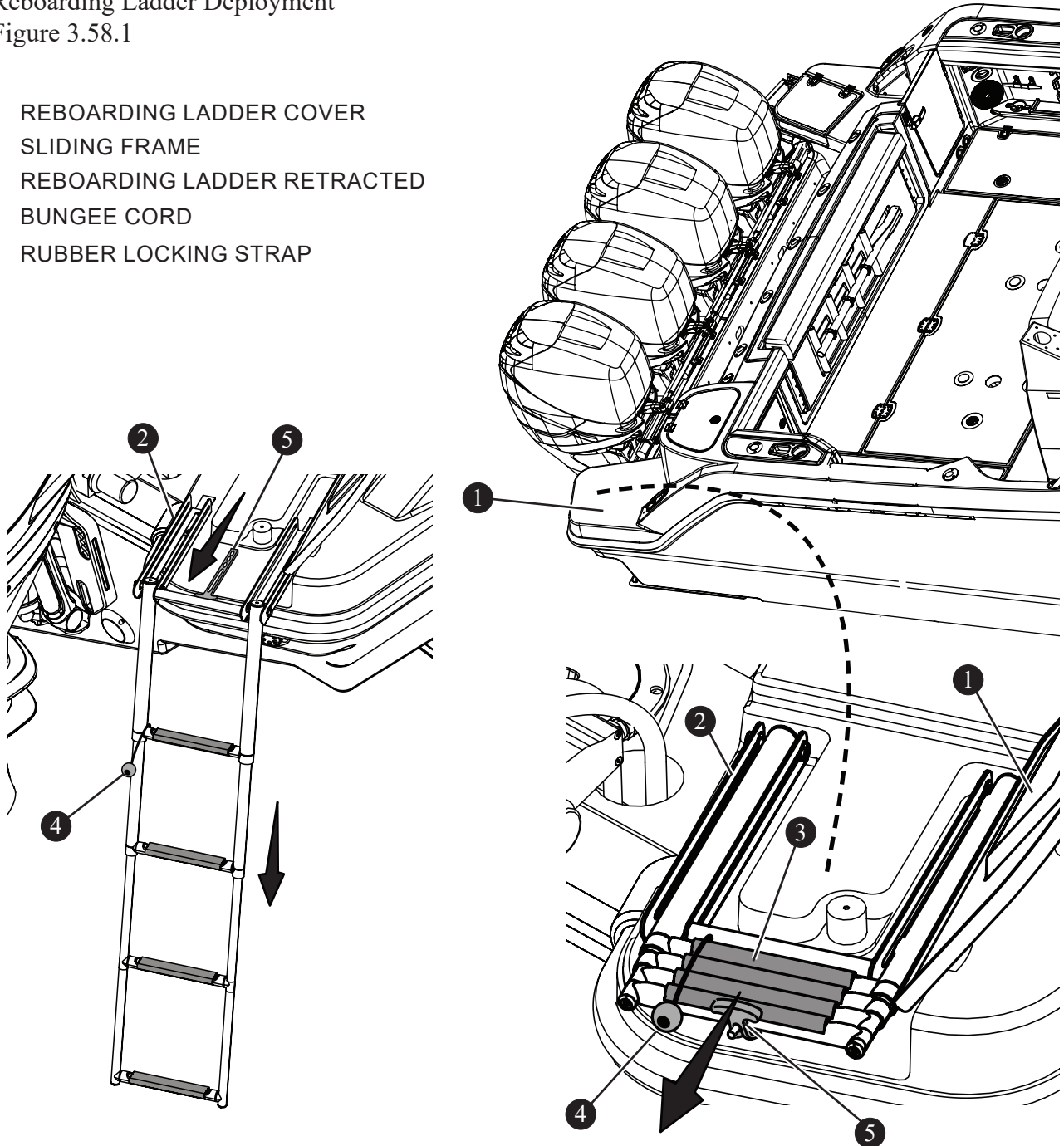

Gyroscopic Stabilizer (Option)

The gyroscopic stabilizer, located in the center of the aft mechanical access hatch (see Figure 3.59.1), reduces boat roll motion independent of boat speed. This keeps the vessel more stable for moving around the deck and cabin, and helps reduce motion sickness. The remote display is located in the cabin (see Figure 3.59.2) but this information can also be accessed at the helm display. Start generator to use gyroscopic stabilizer.

REFER TO OWNER'S PACKET FOR COMPLETE INSTRUCTIONS AND WARRANTY INFORMATION.

! WARNING

Gyroscopic stabilizer cover prevents personnel or equipment from contacting unit while in operation; keep covered. Do not step on or place anything on cover. If contact is necessary while unit's flywheel is spinning, lock control at remote display to stop gyroscopic stabilizer from precessing (tilting). Maintenance should not be attempted unless gyroscopic stabilizer is locked and the flywheel has stopped spinning.

Gyroscopic Stabilizer Display (Option)
Figure 3.59.2

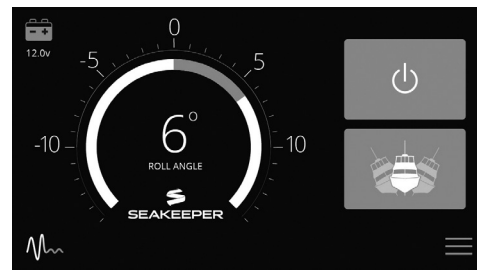

Gyroscopic Stabilizer (Option)
Figure 3.59.1

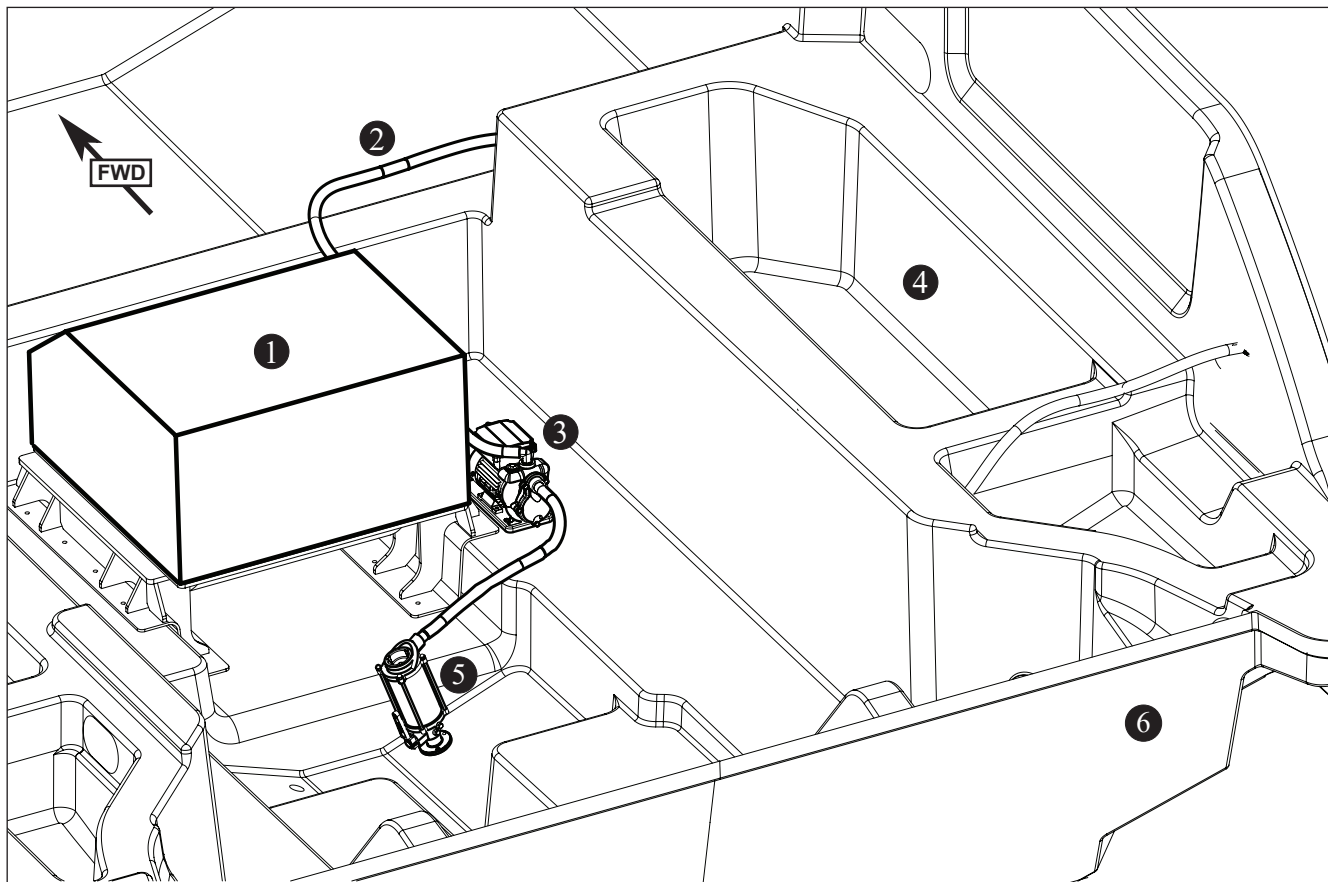

- 1 GYROSCOPIC STABILIZER
- 2 TO THRU HULL OUTLET
- 3 PUMP

- 4 STARBOARD FISHBOX
- 5 RAW WATER SEACOCK
- 6 TRANSOM

Propeller

DANGER

Disconnect power by moving the battery switches to the off position prior to removing the propeller for maintenance, etc.

WARNING

Rotating propeller may cause serious injury or death. Shut off engine when near persons are in water.

NOTICE

Always carry spare propellers, propeller hardware and a propeller wrench on board. Should propellers become damaged they can then be easily replaced.

Under no circumstances use a propeller which allows the engine to operate at a higher than recommended RPM.

The engines on this vessel have been equipped with propellers best suited for general use under normal conditions and load to achieve maximum RPMs which meet Mercury requirements.

Propellers have two basic characteristics, diameter and pitch. Diameter is that distance measured across the propeller hub from the outer edge of the 360 degrees that is made by the propeller's blade during a single rotation. Pitch is that distance in inches that a propeller will travel if rotated one revolution without any slippage.

In general, changing to a lower pitch propeller will increase acceleration and load pulling capability, with a slight decrease in top end speed. If you choose to change propellers, be sure to consult a Boston Whaler dealer.

All propellers are designed to provide maximum forward thrust. Consequently, the reverse thrust of the propeller will not be as efficient.

Changing Propellers

In some situations you may wish to change the propeller to give this vessel slightly different performance characteristics.

In general, changing to a lower pitch propeller will increase acceleration and load pulling capability, with a slight decrease in top end speed. If you choose to change propellers, the type should be discussed with your Boston Whaler dealer. All propellers are designed to provide maximum forward thrust, consequently, the reverse thrust of the propeller will not be as efficient. Propellers have two basic characteristics, diameter and pitch.

Diameter is that distance measured across the propeller hub from the outer edge of the 360 degree that is made by the propeller's blade during a single rotation.

Pitch is that distance in inches that a propeller will travel if rotated one revolution without any slippage.

Anchoring

WARNING

Swamping hazard - Anchor from the bow if using one anchor. A small current can make a stern-anchored boat unsteady. A heavy current can drag a stern anchored boat underwater.

Collision hazard - Anchor only in areas where the boat will not disrupt other boats. Do not anchor in a channel or tie up to navigational aids as it is both dangerous and illegal.

WARNING

Keep hands, feet, hair and loose clothing clear of moving parts (anchor, rode, etc.). Entanglement may cause severe bodily injury (i.e. lose of fingers or toes).

CAUTION

Be careful trailing lines do not foul the propeller.

CAUTION

To avoid property damage, engage gypsy lock and ensure anchor is secured with lanyard before getting underway.

NOTICE

Before using the anchor be sure the anchor line is securely attached to the eye in the bottom of the anchor locker and to the anchor itself.

NOTICE

Turn on the anchor light when at anchor or drifting (not under power) at night or in low visibility.

REFER TO THE OWNER'S PACKET FOR COMPLETE INSTRUCTIONS AND WARRANTY INFORMATION.

Anchoring Operation

To anchor, turn bow into the wind or current and put the engines in neutral. When the boat comes to a stop, lower the anchor from the bow (see Figure 3.61.1 and Figure 3.62.1). Proper anchoring requires knowledge of rode and scope and understanding the relationship between rode, scope and anchor performance.

Rode: The rode is the line connecting the anchor to the boat. Nylon line is ideal because it is light, strong and stretches, it also can be stored wet and is easy to handle. Adding a length of chain between the anchor and the nylon line will help set the anchor more easily.

Scope: The scope is technically defined as the ratio of rode length to the vertical distance from the bow to the sea floor. Scope also depends on the type of anchor, tides, winds, sea conditions and type of sea floor the anchor is in. To determine how much rode to use when anchoring, use this common formula:

Rode length = (bow height + water depth) × scope

The minimum is 5:1 for calm conditions; normal is 7:1, and severe conditions may require 10:1.

Example:

Rode length = (3 feet + 10 feet) × 7*

Rode length = 13 feet × 7*

Rode length = 91 feet

* Scope may range from 5 to 10 or more. However, less than 5, the anchor will break out too easily.

Considerations

- Wind and sea conditions can affect the boat.
- Because the boat is not moving through the water, there is no control.
- Be sure that the anchor will hold under all circumstances if you are leaving the boat.
- Understand the principles of rode and scope and their effect on anchor performance.

Anchor and Windlass
Figure 3.62.1

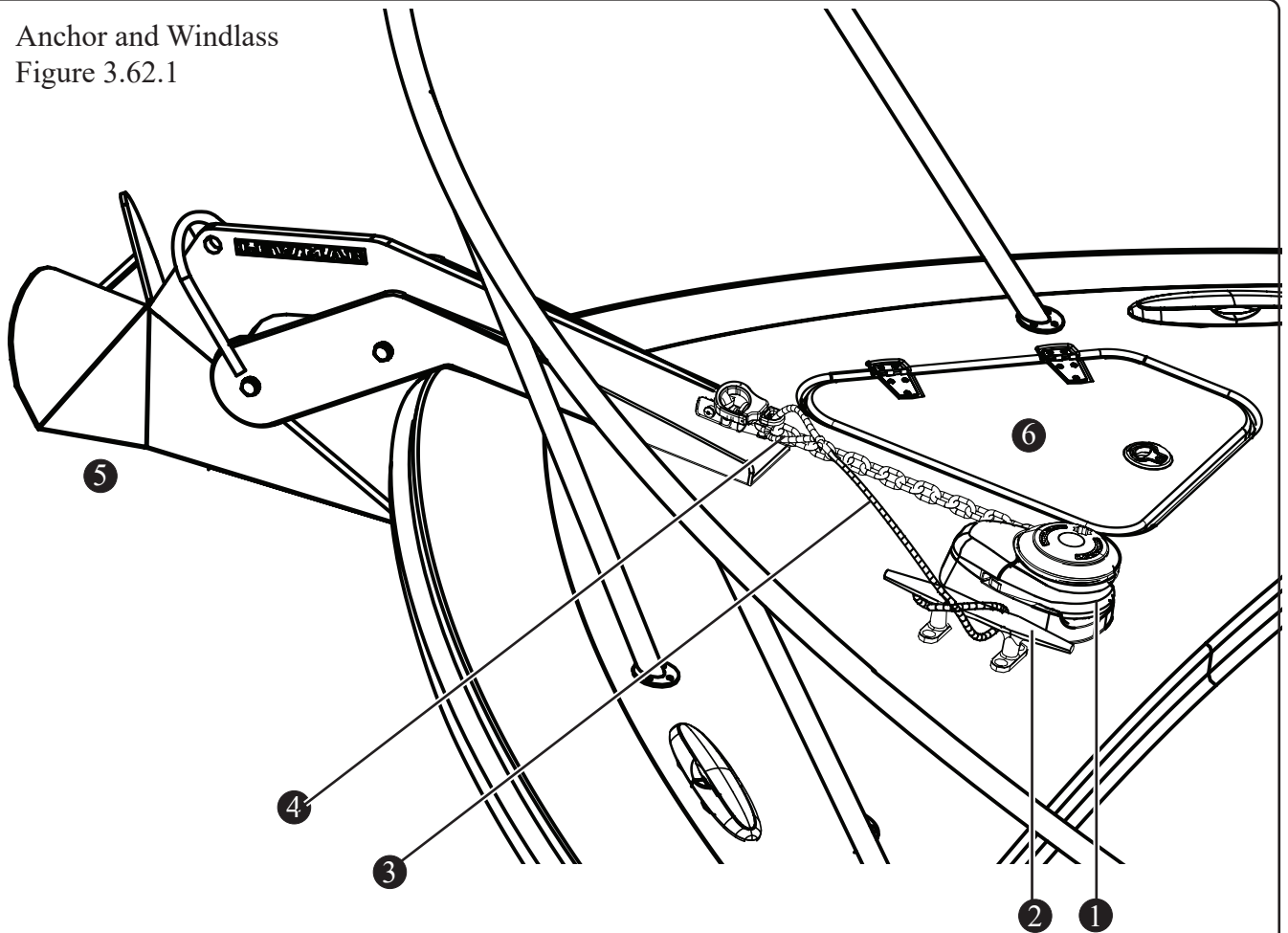

- 1 WINDLASS
- 2 CLEAT
- 3 ANCHOR LANYARD
- 4 CHAIN RODE
- 5 ANCHOR
- 6 ANCHOR LOCKER
- 7 WINDLASS REMOTE
- 8 EMERGENCY HANDLE
- 9 REMOTE CABLE
- 10 REMOTE RECEPTACLE
- 11 FRESHWATER FAUCET

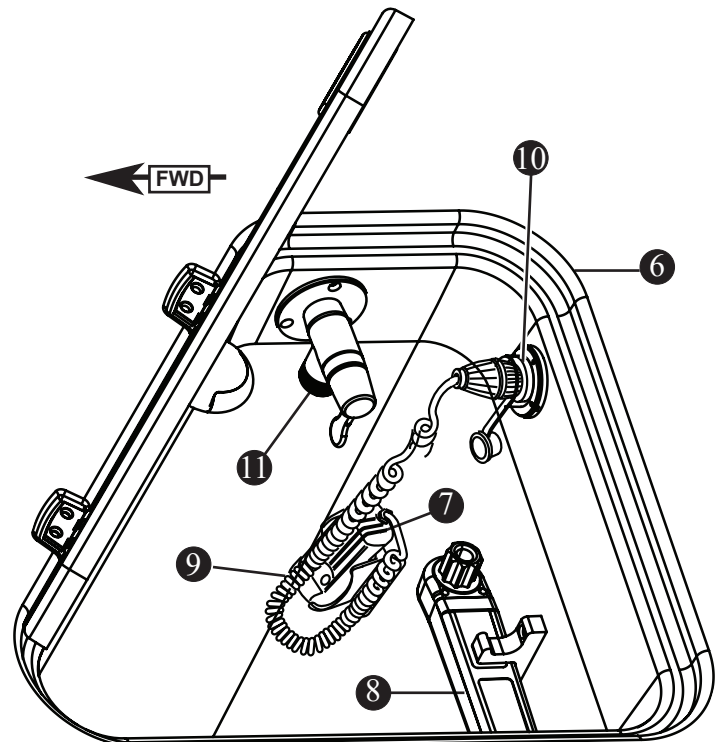

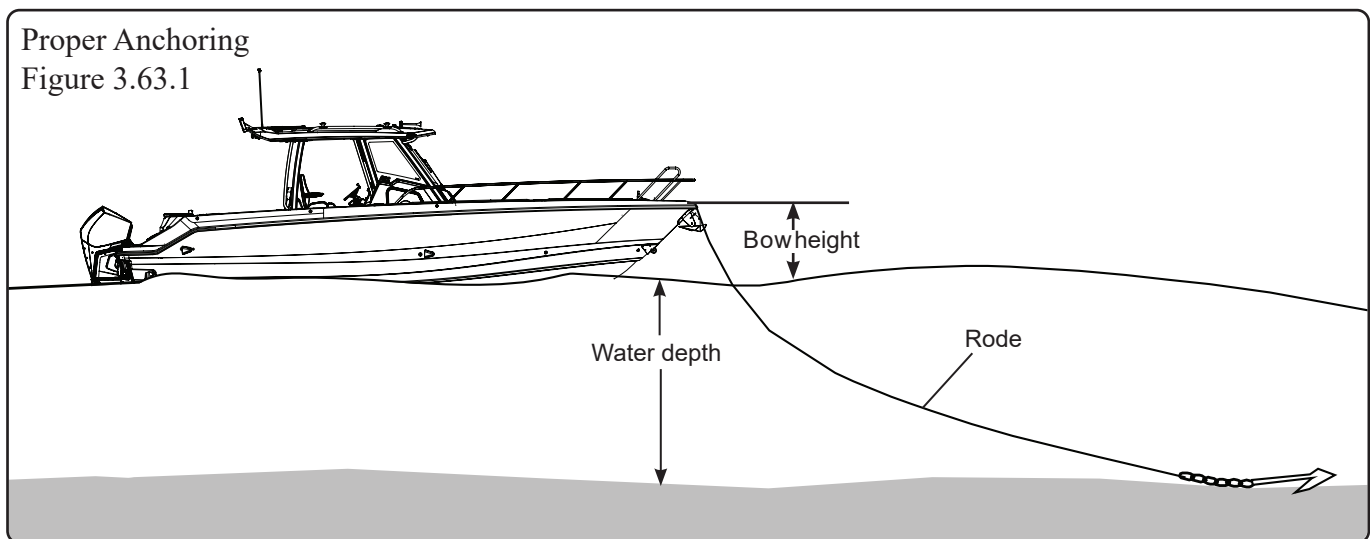

$$\text{Rode length} = (\text{bow height} + \text{water depth}) \times \text{scope}$$

Because there are a variety of anchors, for a variety of uses, discuss the types of anchors with your dealer to find the right anchor for this vessel.

Lowering the Anchor

- Be sure there is adequate rode.
- Secure rode to both the anchor and the boat.
- Stop completely before lowering the anchor.
- Keep feet clear of lines.

If using the optional windlass, refer to the windlass operator's manual for anchoring instructions.

Setting the Anchor

There is no best way to set an anchor. Experiment to see how it performs. One method is to turn the rode around a bitt or a cleat and slowly pay out as the boat backs from the anchor site. When the proper scope has been reached snub the rode quickly, causing the anchor to dig in to the sea bottom.

- Reverse the engine slowly to drive the anchor in and to prevent it from dragging
- Secure the rode to a bitt or cleat

Weighing the Anchor

To weigh or retrieve the anchor, start the boat and run slowly up to the anchor, taking up the rode as you go. The anchor will usually break out when the rode becomes vertical. Coil lines to let them dry before stowing. The bow storage compartment located in the starboard bow should be used to stow the anchor line.

Anchor Lanyard

Do not depend on the windlass to hold the anchor in place. Always secure the anchor with the anchor lanyard, a line attached to the anchor eye and fastened to the bow pulpit cleat when the anchor is stowed and the boat is underway (see Figure 3.62.1).

Anchor Windlass

NOTICE

Be sure to read and fully understand the anchor windlass instructions included in the owner's packet before operating the anchor windlass.

The windlass, located at the bow of this vessel (see Figure 3.62.1 and Figure 3.63.1), is a winch used to raise or lower the anchor. The windlass gypsy is a notched ring that meshes with chain links to raise the anchor. The gypsy lock, when engaged, secures the notched ring in place, preventing the anchor from being accidentally deployed. The anchor lanyard serves as a backup for the gypsy lock.

NOTICE

Always secure the lanyard when underway. Failure to do so may result in accidental deployment of the anchor.

The windlass can be operated from the helm, from the bow with the remote control, or manually. The windlass breaker on the DC main distribution panel must be turned on.

Helm Operation

The windlass is controlled at the helm by three helm switch panel switches. Press the *WINDLASS* switch to power it on.

Lowering the Anchor

Push the *UP/DWN* switch to power the anchor windlass up or down. Make certain that the anchor lanyard is detached from the chain and is clear of any moving parts of the anchor windlass.

Raising the Anchor

Pushing the lower part of the *Up/Down* switch powers the anchor windlass up. Once the anchor is secure in the up position, engage gypsy lock and re-attach the lanyard to the rode.

Emergency Windlass

If there is a loss of power to the windlass, the anchor can be raised and/or lowered manually with the emergency handle located in the anchor locker (see Figure 3.61.1).

REFER TO THE OWNER'S PACKET FOR COMPLETE INSTRUCTIONS AND WARRANTY INFORMATION.

Remote Operation

⚠ DANGER

Use the anchor windlass switch on the helm when possible. Use care when operating the anchor windlass with the hand-held remote.

NOTICE

Before operating windlass, be sure safety lanyard is removed from anchor chain and is clear of the rode as it plays out or is retrieved.

The anchor windlass can be operated from the bow with the use of the windlass remote which is stowed in the anchor locker. To use:

- On helm switch panel, press *WINDLASS* button.
- If not already plugged in, plug power cable into power inlet in the anchor locker.
- Turn forward portion of plug clockwise to lock.
- To raise anchor, press and hold on *UP* button on remote.
- To lower the anchor, press and hold on the *DOWN* button on the remote.

If there is a loss of power to the windlass, check the windlass circuit breaker located on the battery switch breaker panel. If the breaker is tripped, reset the breaker by pushing the lever up. If the breaker continues to trip, have the anchor windlass system checked by a qualified marine electrician.

Towing, Docking, and Lifting

Towing

WARNING

Towing or being towed places extreme tension on tow lines and strong points (cleats, bow stern/eyes). Do not stand directly in line with tow line. Serious injury or death and/or vessel damage may occur if towing gear fails.

If it becomes necessary to have this vessel towed, the U.S. Coast Guard or a private salvage company experienced in this type of operation are better equipped to perform this service. Only use another recreational boat as a last resort as doing so may cause damage to one or both boats due to operator inexperience or other conditions such as weather and/or current. The other boat may assist by standing by and keeping the disabled boat's bow at the proper angle until help arrives.

When towing is necessary, create a bridle with a line around the hull or use spring lines to secure the disabled vessel to the towing vessel (see Figure 3.65.1), whenever possible. Either of these methods distributes the load over a wide area. Be sure to use fenders or other chafe protection at pressure points.

Towing
Figure 3.65.1

BRIDLE

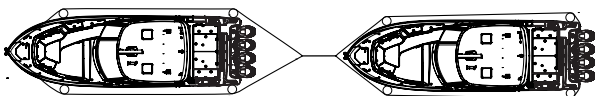

SPRING LINE

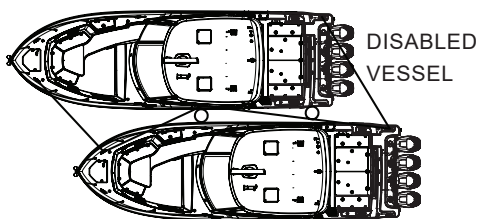

The bow eye, reinforced with a stainless steel backing plate (see Figure 3.65.2), is typically used to haul out and hold this vessel on a trailer.

Bow Eye
Figure 3.65.2

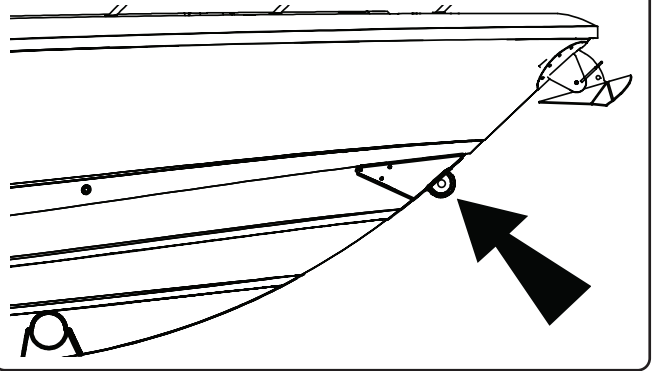

Before operating with a boat in tow, seek professional advice and/or training (e.g., USCG Auxiliary, US Power Squadrons, or BoatUS) to master towing fundamentals. While operating with a boat in tow there are several regulations and guidelines that must be followed:

- Display the proper markings and navigation lights on towing vessel and disabled vessel.
- Disabled vessel should never be larger or heavier than towing vessel.
- Ensure all tow lines/bridle are adequately sized and in good condition.
- Only secure tow lines to strong points designed for towing (bow/stern eyes, reinforced cleats).
- Designate experienced crew to monitor, identify, and manage risks.
- Always monitor WhalerWatch while towing, when installed.
- While underway, be prepared to adjust tow line length and speed to meet current conditions.

Docking

This vessel has seven cleats (see chapter 2, *Overview*), for securing the boat to the dock. While loading/unloading or mooring, learn the proper way to secure the boat and how best to use the boat's mooring points (see Figure 3.66.1).

Belaying Knot Figure 3.66.1

(Make loop and rotate before pulling over the horn.)

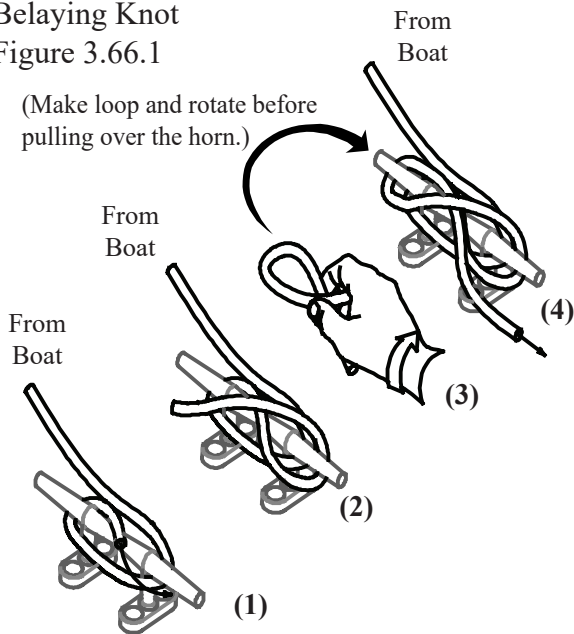

storage consider the following:

- If you are using a professional lifting service, it is prudent to check all credentials and ask for proof of insurance to protect your investment.
- Ensure that fishboxes and bilge are pumped out prior to lifting.
- Use a wide, flat, belt sling for lifting to minimize stress on the gunwales.
- Carefully place slings (see Figure 3.66.2), where contact with underwater fittings will not occur.
- When secured on land, pull the garboard drain, ensure that motorwell drains and deck drains are free flowing and position the bow slightly higher than the stern so water can easily drain from the boat.
- Before removing boat from water be sure to close A/C seacock. Failure to do so causes an in-line air lock when boat is returned to the water. The A/C system must be primed before it operates properly.

Lifting

Do not use the bow eye (see Figure 3.65.2), for lifting the boat. Whether you are lifting this vessel out of the water for short-term maintenance or long-term

Long Duration Lifting Figure 3.66.2

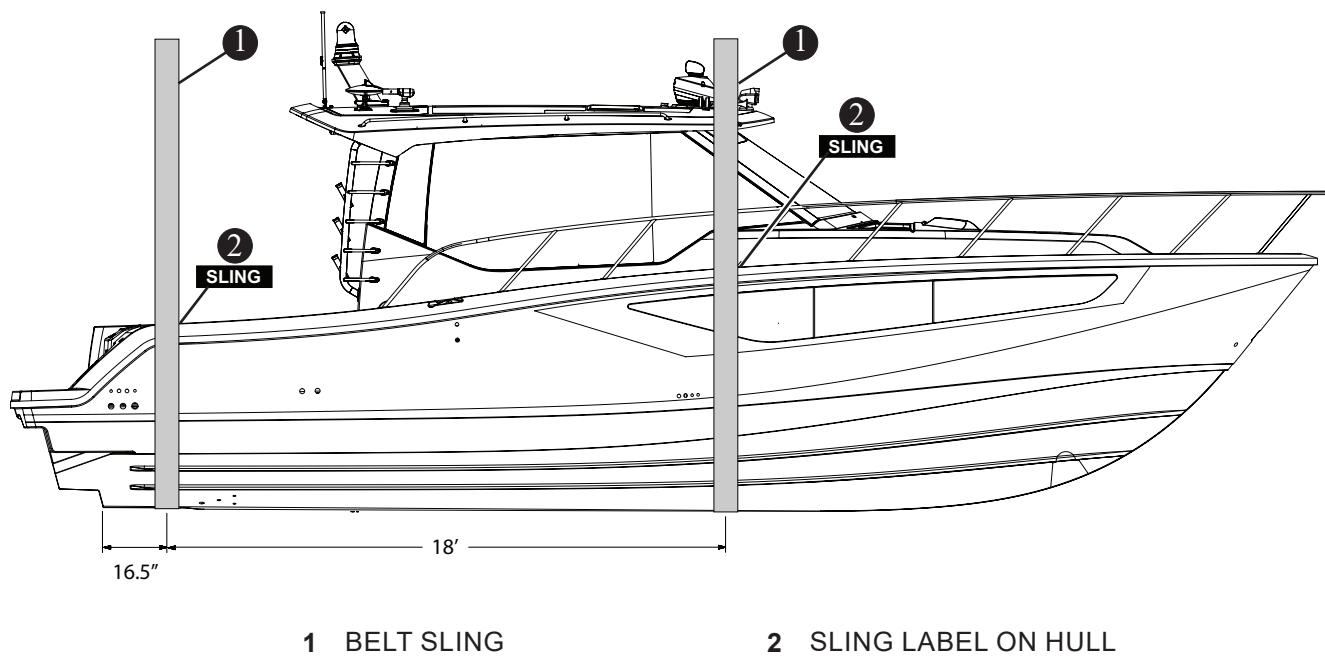

Out of Water Storage

Out of water storage requires correct vessel support to prevent hull damage. Support the boat with a minimal of three keel stands. Contact a Boston Whaler dealer for specific requirements. In the event the required keel stands are not available, see Figure 3.67.1 and Figure 3.68.1 for recommended out of water support for boat.



CAUTION

In addition to wood blocks, use a minimum of four side stands (two port and two starboard). Wood blocks must contact hull for a minimum length of 8 inches each. Side stands for stability only and not intended to be load bearing.

Keel Stands
Figure 3.67.1

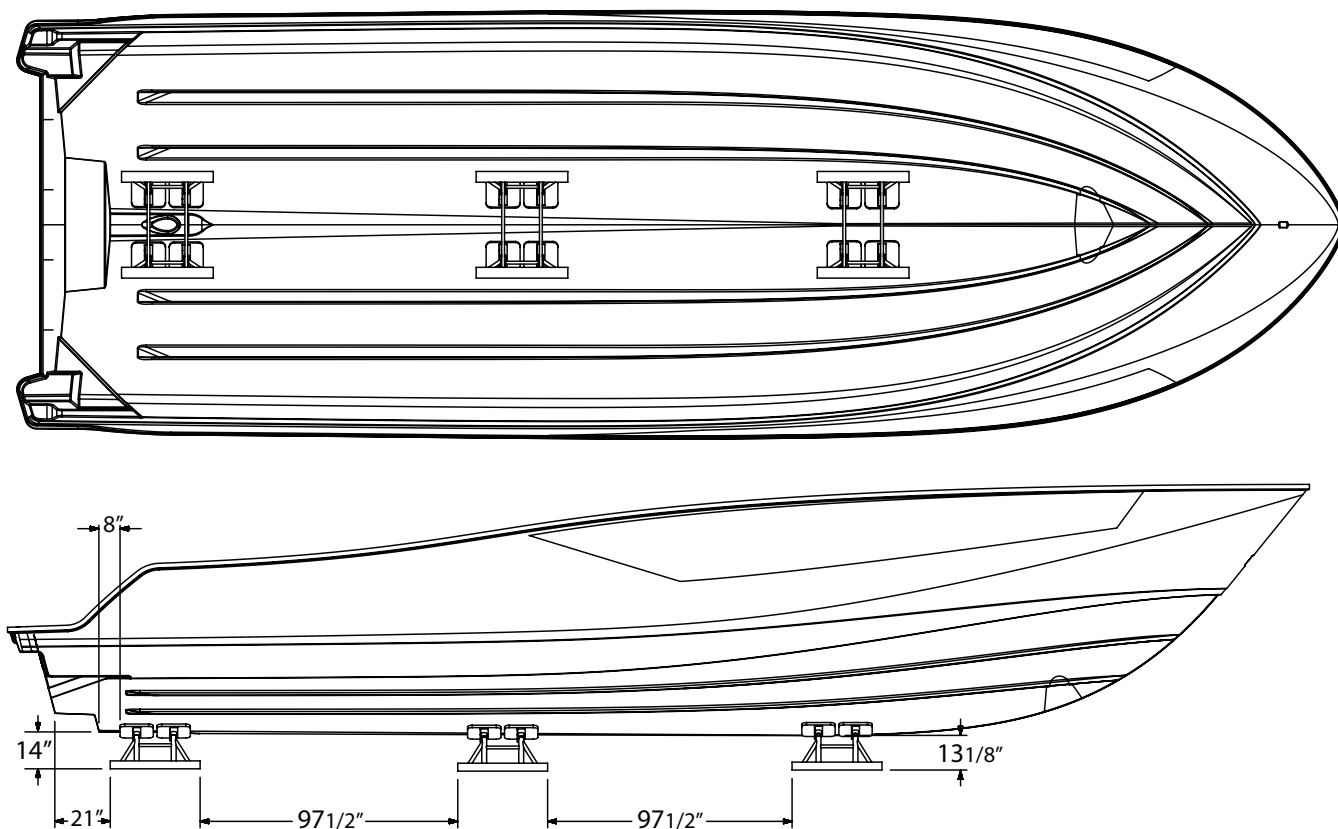

Wood Blocks
Figure 3.68.1

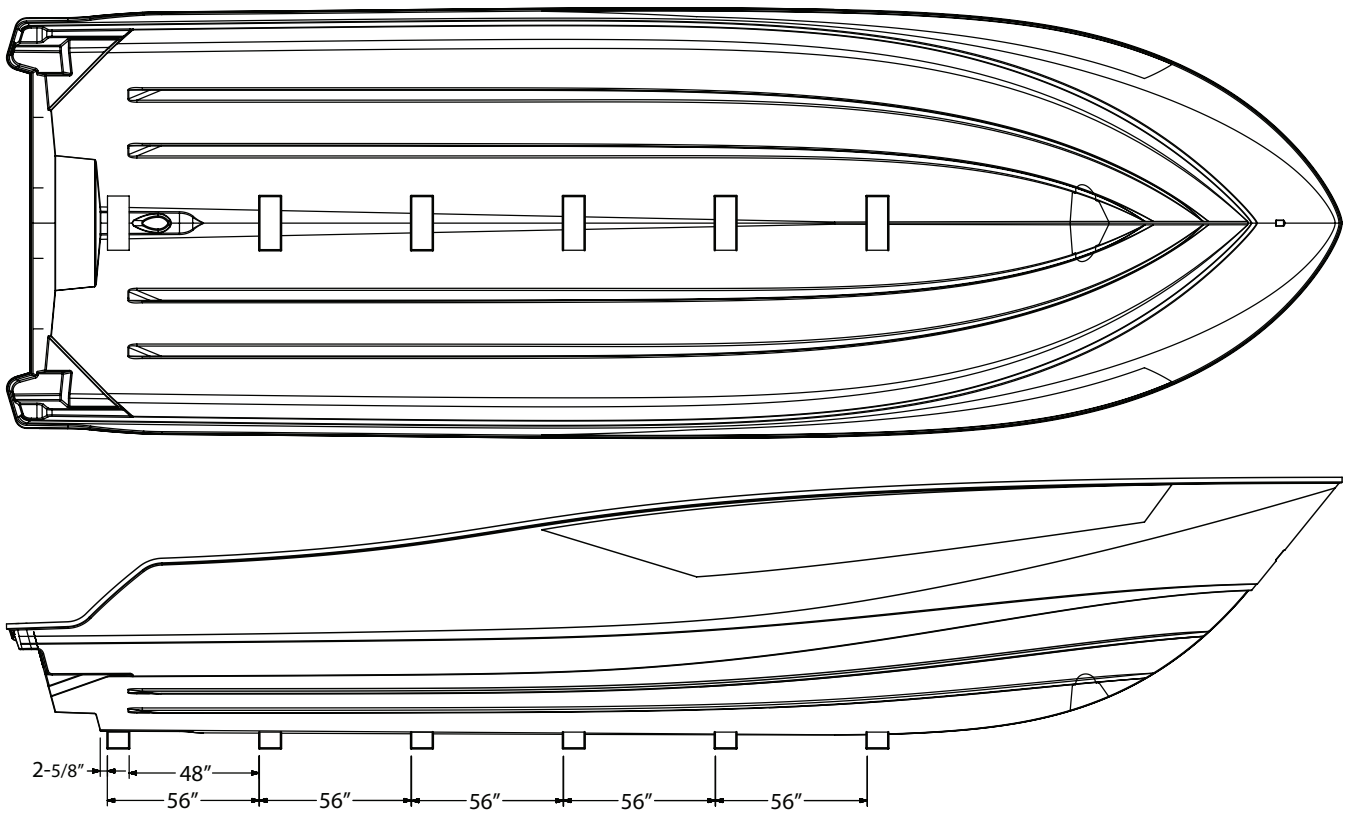

DC Electrical System

This vessel's DC electrical system is powered by a series of batteries that are charged when the engines are running, by the generator or can be charged by shore power when the engines and generator are off. Battery banks include engine, house/generator, and the bow thruster. The house batteries power all onboard systems. Battery chargers, located in the forward and aft mechanical access hatches (shown later in this chapter), facilitate battery charging when using shore power. See chapter 3, *Systems Overview and Operation* for shore power operation. The electrical system utilizes remote battery switches to control delivery of power to the following:

- Electrical system (all ignition, tilt, trim, joystick)
- Bow thruster system (motor, joystick, controls)
- Generator system (generator control panel)
- House system (electronics, helm control panel, digital control, windlass, stereo, lighting)

Batteries

⚠ DANGER

Batteries contain sulfuric acid which can cause serious injury. Avoid contact with skin, eyes and clothing. If contact occurs, flush affected area with water and seek medical attention.

NOTICE

Ensure batteries meet Mercury's AGM/CCA requirements.

Store batteries in battery trays. Use retaining lid and nylon lock nuts to keep batteries secure.

REFER TO ENGINE MANUFACTURER'S MANUAL IN OWNER'S PACKET FOR COMPLETE INSTRUCTIONS AND WARRANTY INFORMATION.

Use only AGM batteries with Mercury Verado engines. Table below is for reference purposes only.

Application	Group	Volts	MCA*	RC 25	Qty.**
USA (SAE)	31	12	800	135 min	9

*Marine cranking amps

**Joystick piloting option deletes the two bow thruster batteries.

Application	Group	Volts	CCA*	Reserve	Qty.**
International (EN)	31	12	975	65Ah	9

*Cold Cranking Amps

**Joystick piloting option deletes the two bow thruster batteries.

Battery Trays

This vessel uses a combination of battery trays and a battery box to secure the house batteries (see Figure 4.2.1) Batteries should always be secured in the battery trays provided and secured in place by the retaining brackets. The trays ensure that while underway the batteries do not move around, thus causing damage to components fitted in the same area. The batteries can be removed from the trays by first removing the negative wires followed by the positive wires. Then remove the retaining lid and hold down on the battery tray.

Standard Battery Plate

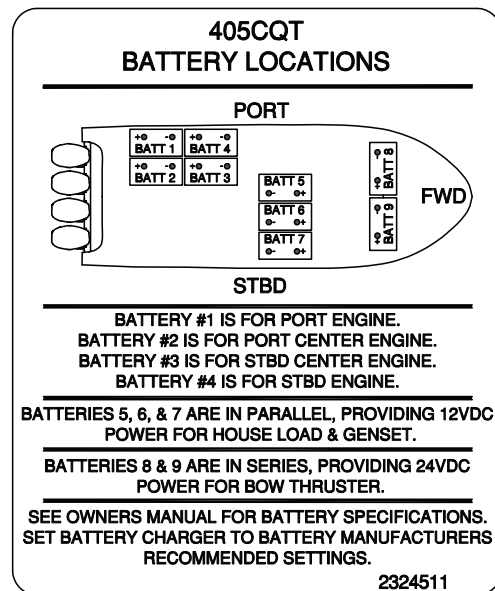

V12 Engine Equipped Battery Plate

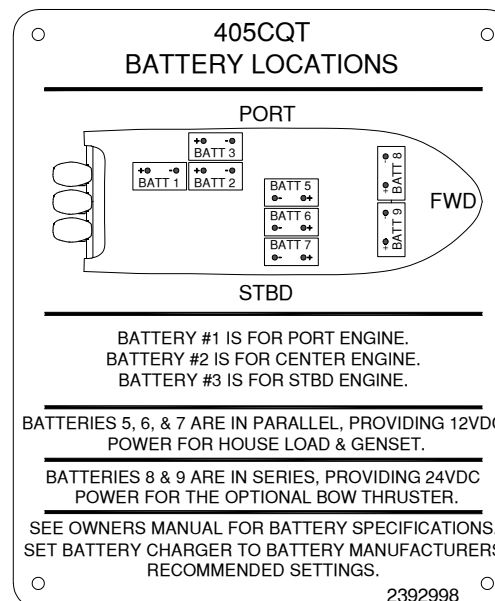

Battery Locations
(Figure 4.2.1)

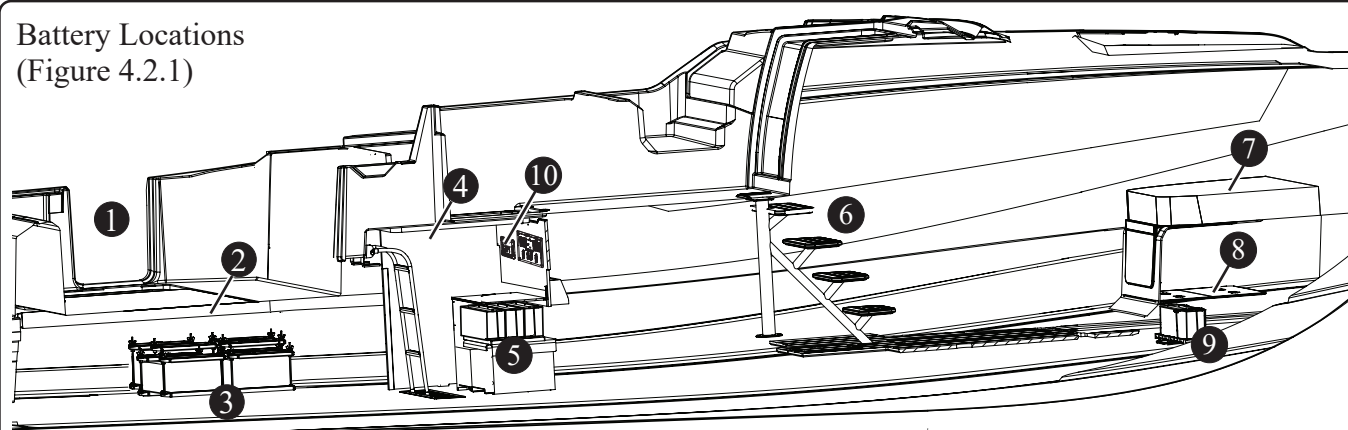

- | | |
|-----------------------------------|-----------------------------------|
| 1 DIVE DOOR | 6 STEPS INTO CABIN |
| 2 AFT MECHANICAL ACCESS HATCH | 7 STATEROOM BED |
| 3 ENGINE BATTERIES | 8 ACCESS PANEL UNDER BED |
| 4 FORWARD MECHANICAL ACCESS HATCH | 9 BOW THRUSTER BATTERIES (OPTION) |
| 5 HOUSE AND GENERATOR BATTERIES | 10 HOUSE BATTERY CHARGER |

NOTE: When equipped with optional V12 engines, battery configuration varies.

Battery Chargers

The house and engine battery chargers (see Figure 4.2.1 and Figure 4.3.1 respectively) automatically increase current output when a drop in battery voltage occurs. When charged, the unit maintains a small current flow to keep batteries fully charged and ready for service without overcharging. Keep battery chargers on at all times to maintain proper voltage and battery integrity.

CAUTION

- No open flame or spark in battery area
- Battery will explode if flame or spark ignites free hydrogen given off during charging
- Always disconnect battery before doing work or maintenance on electrical system
- With engines running, never turn off battery switches or disconnect battery cables

Overload Protection

If a short or overload occurs in the electrical system battery chargers reduce output voltage to avoid internal damage, and a red light on front panel of unit is illuminated. The overload or short must be removed before charger resumes charging characteristics.

Remote Battery Switches

This vessel uses remote battery switches (RBS)

for each engine (see Figure 4.3.1 and Figure 4.4.1) and one for house power (see Figure 4.11.1). These switches are used to control delivery of DC power from the batteries. Each battery switch on the DC distribution panel (see Figure 4.6.1) is wired to the associated remote battery switch.

NOTICE

When remote battery switches are off, they still draw battery power together with features such as bilge pumps and WhalerWatch.

Automatic Charging Relays (ACR)

Batteries are automatically connected in parallel through the use of automatic charging relays when a sufficient charging source is present. The battery banks are automatically separated when the charging source falls below a certain voltage level for a predetermined amount of time. The use of automatic charging relays eliminates the need for the operator to monitor battery voltage and decide whether or not to parallel the battery banks. It also minimizes the chance of a dead engine battery if the paralleling switches were left in the combined position without a sufficient charging source present.

Manual Control Override

Each of the remote battery switches and automatic charging relay units have a manual override knob on

Chapter 4 • Electrical

the top of the unit as an added level of safety that allows manual on/off control with or without power and provides lock off for servicing the electrical system (see Figure 4.4.1).

Aft Mechanical Access Hatch

Figure 4.3.1

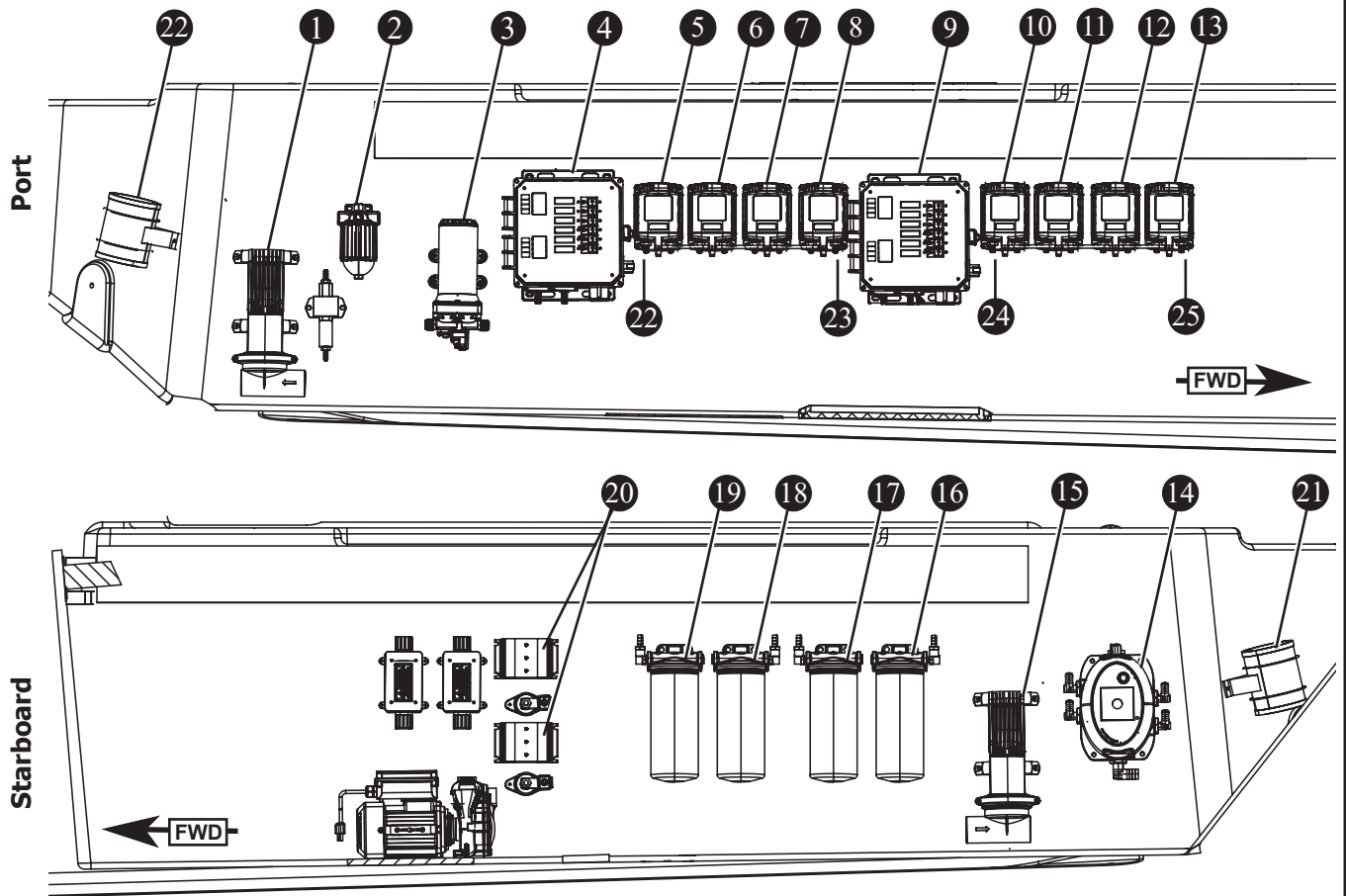

- | | |
|---|--|
| 1 PORT FISHBOX PUMP | 14 ENGINE FLUSH (OPTION) |
| 2 GENERATOR FUEL FILTER | 15 STBD FISHBOX PUMP |
| 3 RAW WATER PUMP | 16 STBD OUTER FUEL FILTER |
| 4 PORT ENGINE BREAKER PANEL | 17 STBD CENTER FUEL FILTER |
| 5 PORT ENG REMOTE BATTERY SWITCH | 18 PORT CENTER FUEL FILTER |
| 6 PORT ENG AUTOMATIC CHARGING RELAY | 19 PORT OUTER FUEL FILTER |
| 7 PORT CENTER AUTOMATIC CHARGING RELAY | 20 AUTO POWER SWITCH |
| 8 PORT CENTER REMOTE BATTERY SWITCH | 21 BILGE BLOWER |
| 9 STBD ENGINE BREAKER PANEL | 22 PORT ENGINE MASTER IGNITION (1 AMP FUSE) |
| 10 STBD ENGINE REMOTE BATTERY SWITCH | 23 PORT CENTER ENGINE MASTER IGNITION (1 AMP FUSE) |
| 11 STBD ENGINE AUTOMATIC CHARGING RELAY | 24 STBD ENGINE MASTER IGNITION (1 AMP FUSE) |
| 12 STBD CENTER AUTOMATIC CHARGING RELAY | 25 STBD CENTER ENGINE MASTER IGNITION (1 AMP FUSE) |
| 13 STBD CENTER REMOTE BATTERY SWITCH | |

NOTE: When equipped with optional V12 engines, equipment configuration varies.

Remote Battery Switch (RBS)/Automatic Charging Relay (ACR)
Figure 4. 4.1

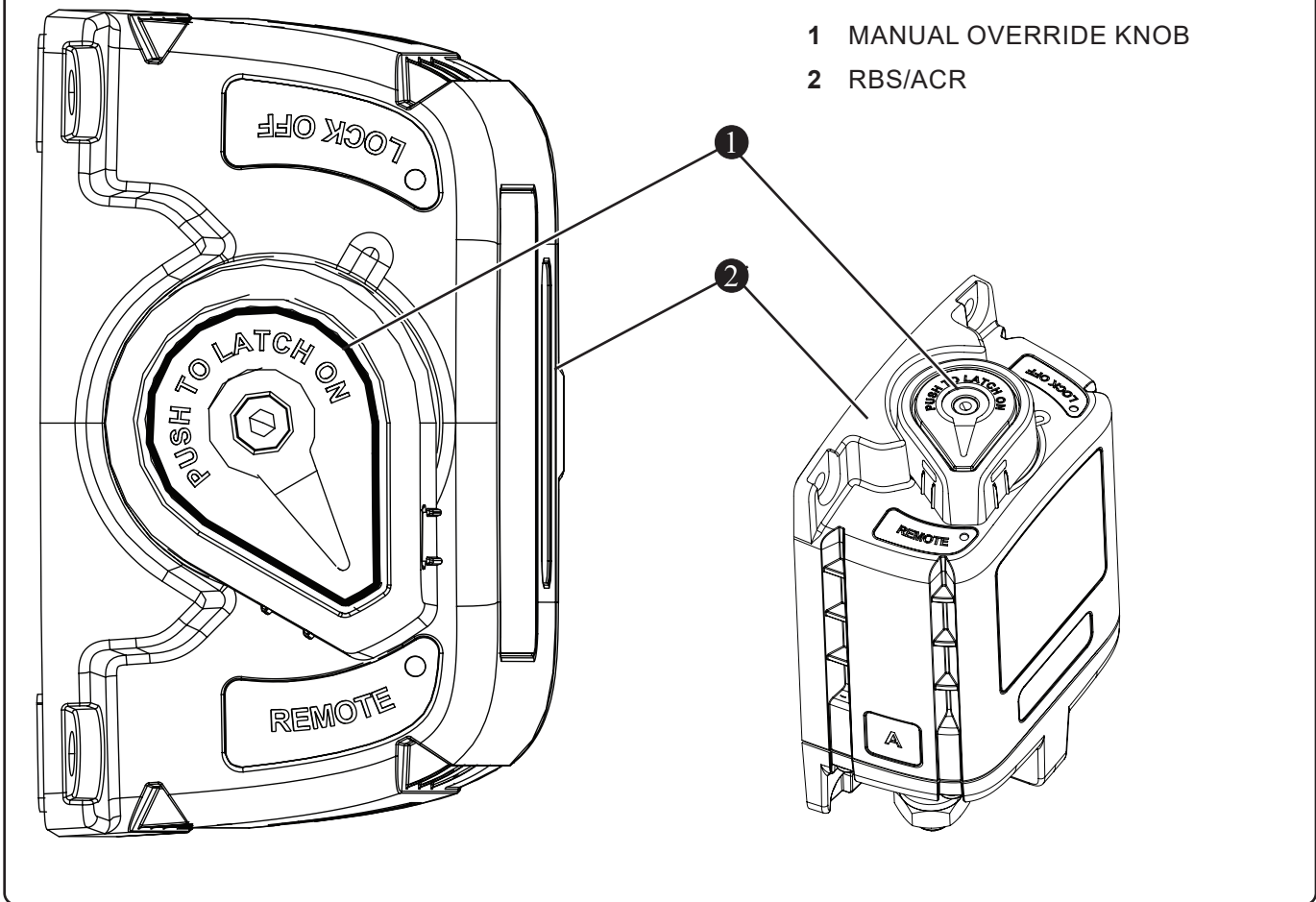

- 1 MANUAL OVERRIDE KNOB
- 2 RBS/ACR

To combine battery banks	With override knob in <i>REMOTE</i> position, push knob down until latched.
To isolate battery banks that are connected	To unlatch, rotate override knob to right (knob pops up); rotate knob back to <i>REMOTE</i> position.
To prevent remote operation	Rotate knob to <i>LOCK OFF</i> position.
To secure for servicing	With knob in <i>LOCK OFF</i> position, pass cable tie through knob slot.

Battery Maintenance

Before use, check each battery and the charging system for loose connections or wiring. Normal maintenance should include:

- Coat the terminals with dielectric grease
- Keep the batteries dry
- Remove the batteries from the boat during cold weather or long term storage.

Discharging a battery to 50 percent charge or 12V before recharging shortens battery life. When a battery discharges, the active material on positive and negative plates converts to lead sulfate, causing the plates to become similar in electrical charge. The electricity conducting battery acid then becomes weaker and the voltage drops. As the battery remains discharged, the process continues until recharging the battery becomes impossible. If a battery does become run down be sure to recharge as soon as possible. Over charging the battery can be just as detrimental to its lifespan as running it down too far.

⚠ DANGER

Batteries contain sulfuric acid which can cause serious injury. Avoid contact with skin, eyes and clothing. If contact occurs, immediately flush affected area with large quantities of water and obtain medical assistance.

⚠ CAUTION

- **No open flame in battery storage area**
- **Avoid striking sparks near battery**
- **Battery will explode if flame or spark ignites free hydrogen given off during charging**
- **Always disconnect battery before doing any work or maintenance on electrical system**
- **With engines running, never turn off battery switches or disconnect battery cables**

This vessel's AC main distribution panel is located on the aft wall of cabin (see Figure 4.7.1).

Ground Fault Circuit Interrupter (GFCI)

⚠ CAUTION

Persons with heart problems or other conditions that are susceptible to electric shock may still be injured by ground faults on circuits protected by a GFCI outlet. No safety devices yet designed will protect against all hazards or carelessly handled or misused electrical equipment or wiring.

This vessel is equipped with four ground fault interrupter outlets. GFCI outlets are designed to protect against line-to-ground shock hazards which could occur from defective tools or appliances operating

from the outlets, or from down-line outlets protected by it.

The GFCI will not prevent line-to-ground electric shock, but does limit the time of exposure to a period considered safe for normal healthy persons.

A GFCI outlet does not protect people against line-to-line or line-to-neutral faults, short circuits or overloads.

If equipped, all readily accessible 220V outlets (international only) are protected by a residual current circuit breaker (RCBO). This current breaker includes a test switch to verify proper operation. Its function is similar, but not identical to a GFCI outlet.

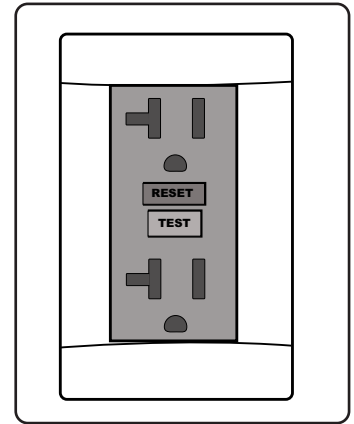

12 Volt Accessory Receptacle

NOTICE

Do not insert a cigarette lighter into receptacle. Damage to the unit and system could occur.

This vessel is equipped with 12V accessory receptacles. The 12V accessory circuit is protected by a 15 amp breaker located on the main DC breaker panel. Be sure not to exceed the rated capacity of the circuit or the breaker will trip.

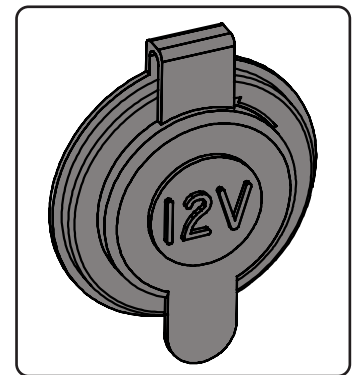

USB Receptacle

This vessel is equipped with USB receptacles, which are each protected by a 2 amp fuse. Be sure not to exceed the rated capacity of the circuit when charging devices..

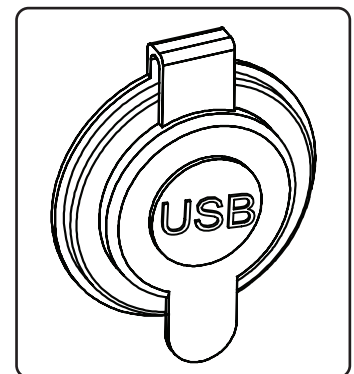

Component Breakers

This vessel utilizes manual reset breakers which are located on both the DC and AC distribution panels (see Figure 4.6.1 and Figure 4.7.1). If a breaker trips, determine and correct the problem before resetting. Should a breaker trip repeatedly, have a qualified marine electrician identify and resolve the issue. If breaker replacement is necessary, use the same amperage as the original. Replacing a breaker with one of lower amperage will not be sufficient to carry the load and cause nuisance breaker tripping. Conversely, replacing a breaker with one of higher amperage will not provide adequate protection against an electrical malfunction, creating a fire hazard.

DC Distribution Panel

Figure 4.6.1

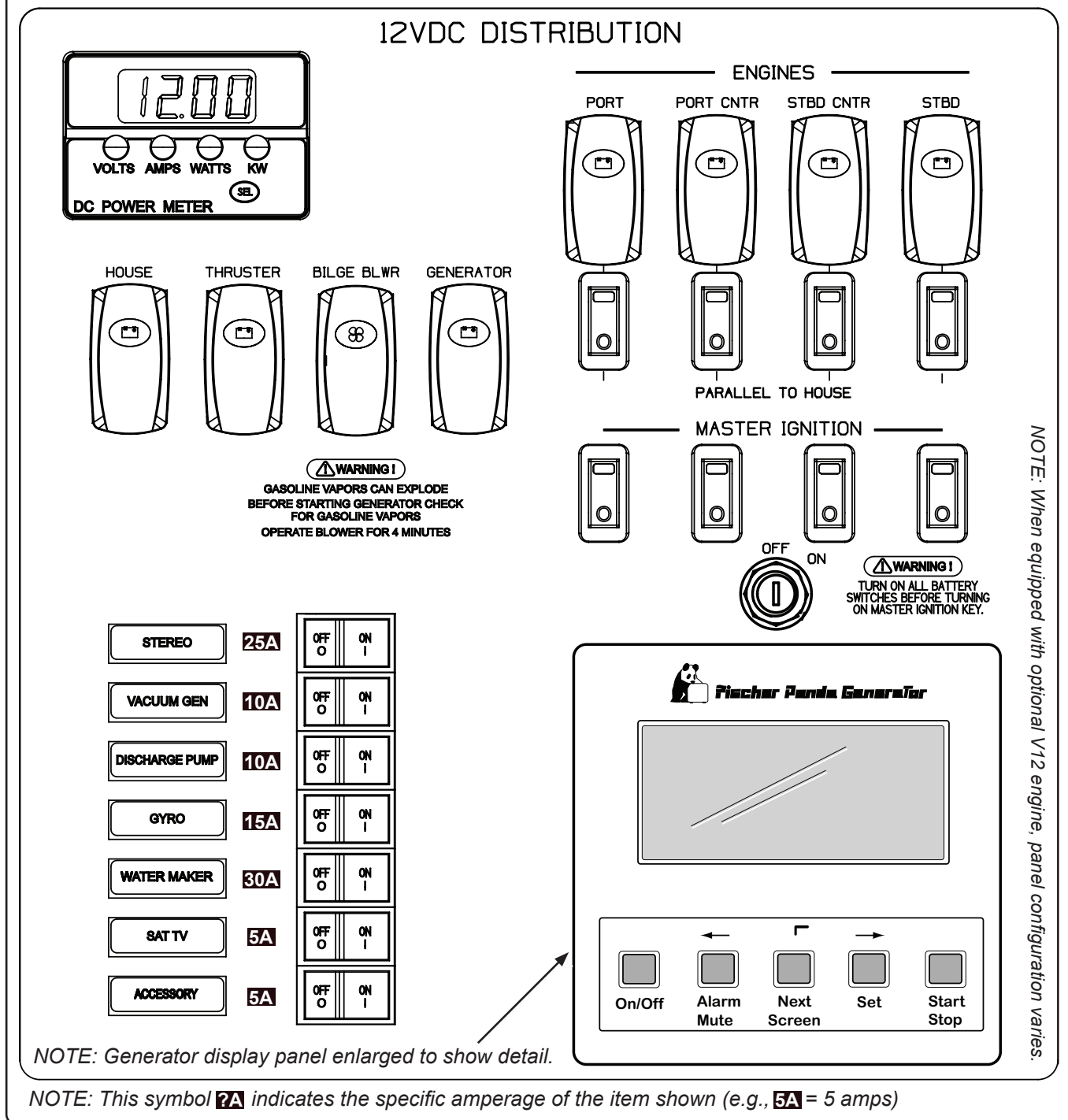

AC Electrical System

This vessel's AC electrical system operates on 240V/60Hz shore power or generator standard equipment. See chapter 3, *Systems Overview and Operation* for information on operation of the generator and the shore power system. The AC main distribution panel is located on the aft wall of the cabin (see Figure 4.7.1). Use the panel's *AC POWER METER* to select between volts, amps, watts, and power factor. When the meter is set to amps, use the selector switch to view amps on *L1* or *L2*.

AC Distribution Panel
Figure 4.7.1

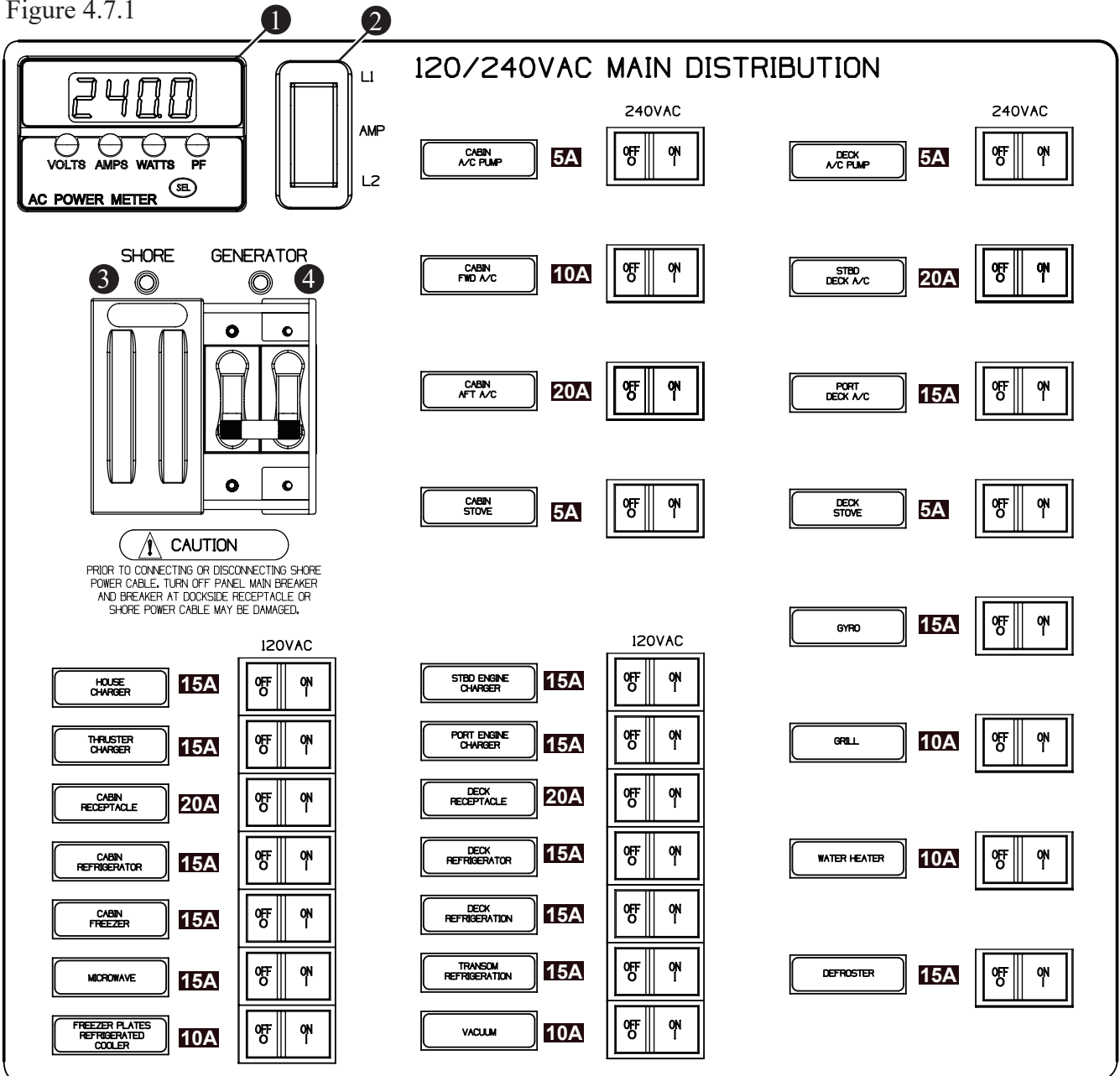

NOTE: This symbol **5A** indicates the specific amperage of the item shown (e.g., **5A** = 5 amps)

- 1 AC POWER METER
- 2 SELECTOR SWITCH

- 3 SHORE MAIN BREAKER
- 4 GENERATOR MAIN BREAKER

Engine Breaker Boxes

Located in the aft mechanical access hatch, the port and starboard engine breaker boxes (see Figure 4.8.1) contain overcurrent protection breakers for the engine battery chargers, power steering pumps, and automatic charging relays. Consult your Boston Whaler dealer for assistance with these units.

Starboard Engine Breaker Box

Figure 4.8.1

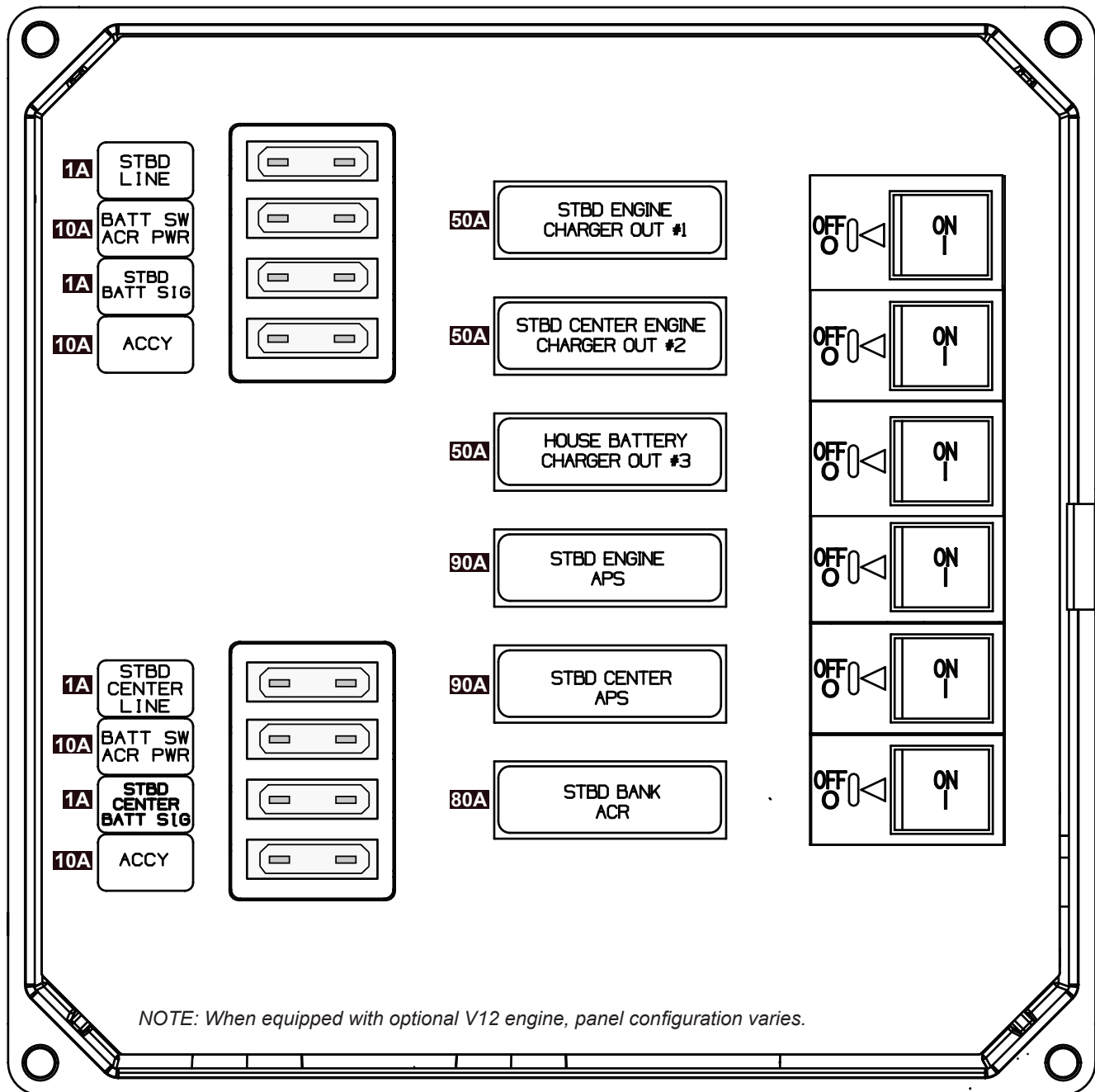

NOTE: Port engine breaker box not shown.

*NOTE: This symbol **7A** indicates the specific amperage of the item shown (e.g., **5A** = 5 amps)*

Main DC Breaker Panel

In this vessel's main DC breaker panel (see Figure 4.10.1), located in the forward mechanical access hatch, are the house remote battery switch, generator battery, disconnect solenoid as well as the main breaker and breaker feeds. The main breaker feeds are for the helm electronics breaker block, electronics fuse block, cabin fuse block, and the DC distribution panel.

WARNING

Use of higher amperage fuses or breakers is a fire hazard. Use fuses and breakers with the same amperage as the original.

Fuse Blocks

Always carry spare fuses. If a fuse is replaced with one of lower amperage, it will not be sufficient to carry the electrical load of the equipment it is connected to and cause nuisance fuse failure or breaker tripping. If a fuse is replaced with one of higher amperage, it will not provide adequate protection against an electrical malfunction and will create a fire hazard. Fuse and breaker block locations are detailed below:

- The cabin fuse block is located in the mid-berth compartment and can be accessed through a panel on the forward wall.

HEAD FAN	4 AMPS
SUMP PUMP	5 AMPS
H/L & MB READING LIGHTS	5 AMPS
TV GAIN	3 AMPS
MODULE #1	50 AMPS
MODULE #2	50 AMPS
ACCESSORY	

- The electronics fuse block is located in the mid-berth compartment and can be accessed through a panel on the starboard wall.

ACCESSORY	5 AMPS
FISH FINDER	5 AMPS
AUTO PILOT	40 AMPS
SAT WEATHER	5 AMPS
NETWORK SWITCH	3 AMPS
RADAR	20 AMPS
INFRARED CAMERA	5 AMPS
AIS	5 AMPS

UPPER VHF	5 AMPS
VHF RADIO	10 AMPS
VHF CHARGER	2 AMPS
VHF CHARGER	2 AMPS

- The CT-6 fuse block is located in the mid-berth compartment and can be accessed through a panel on the forward wall.

ACCESSORY

GALLEY REFRIGERATOR	15 AMPS
PREP STATION REFRIGERATOR	15 AMPS
SUMMER KITCHEN REFRIG (OPTION)	15 AMPS
CABIN FREEZER	15 AMPS
PREP STATION REFRIGERATOR	15 AMPS
SALON TABLE	15 AMPS
RGB LIGHT MODULE	25 AMPS

- The stereo amplifier fuse block is located in the salon lounge area and can be accessed through a panel behind a starboard cushion.

STATEROOM SUBWOOFER AMP	30 AMPS
AMP 3 (SALON SUBWOOFER AMP)	30 AMPS
AMP 2	50 AMPS
AMP 1	40 AMPS

- The electronics breaker block, located at the helm, is accessed from the salon via the starboard aft cabinets. See chapter 2, *General Information* for more location information.

Other Fuse Locations

Main DC Breaker Panel

Two additional fuse blocks are located inside the main DC breaker panel (see Figure 4.11.1).

AC and DC Main Distribution Panels

WARNING

To avoid severe electrical shock or burn, disconnect power before opening this panel.

Chiller system fuses are located in both the AC main distribution panel and the DC main distribution panel. Should servicing of chiller system fuses be required, consult a qualified marine electrician. When accessing fuses, the generator must be turned off and shore power unplugged to avoid an electric shock hazard.

Main DC Breaker Panel (Front)

Figure 4.10.1

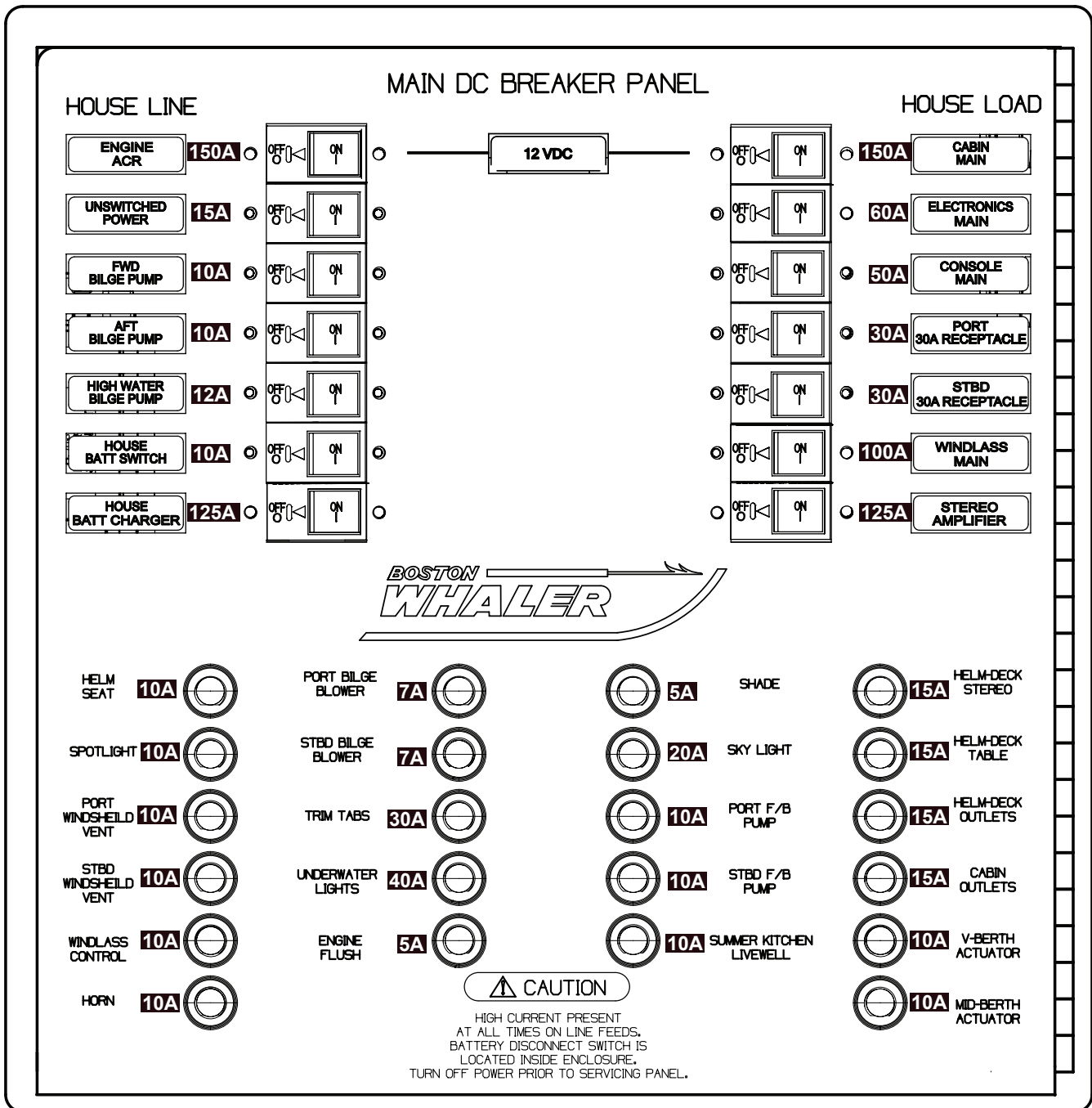

NOTE: This symbol **7A** indicates the specific amperage of the item shown (e.g., **5A** = 5 amps)

NOTE: When equipped with optional V12 engine, panel configuration varies.

Main DC Breaker Panel (Inside)

Figure 4.11.1

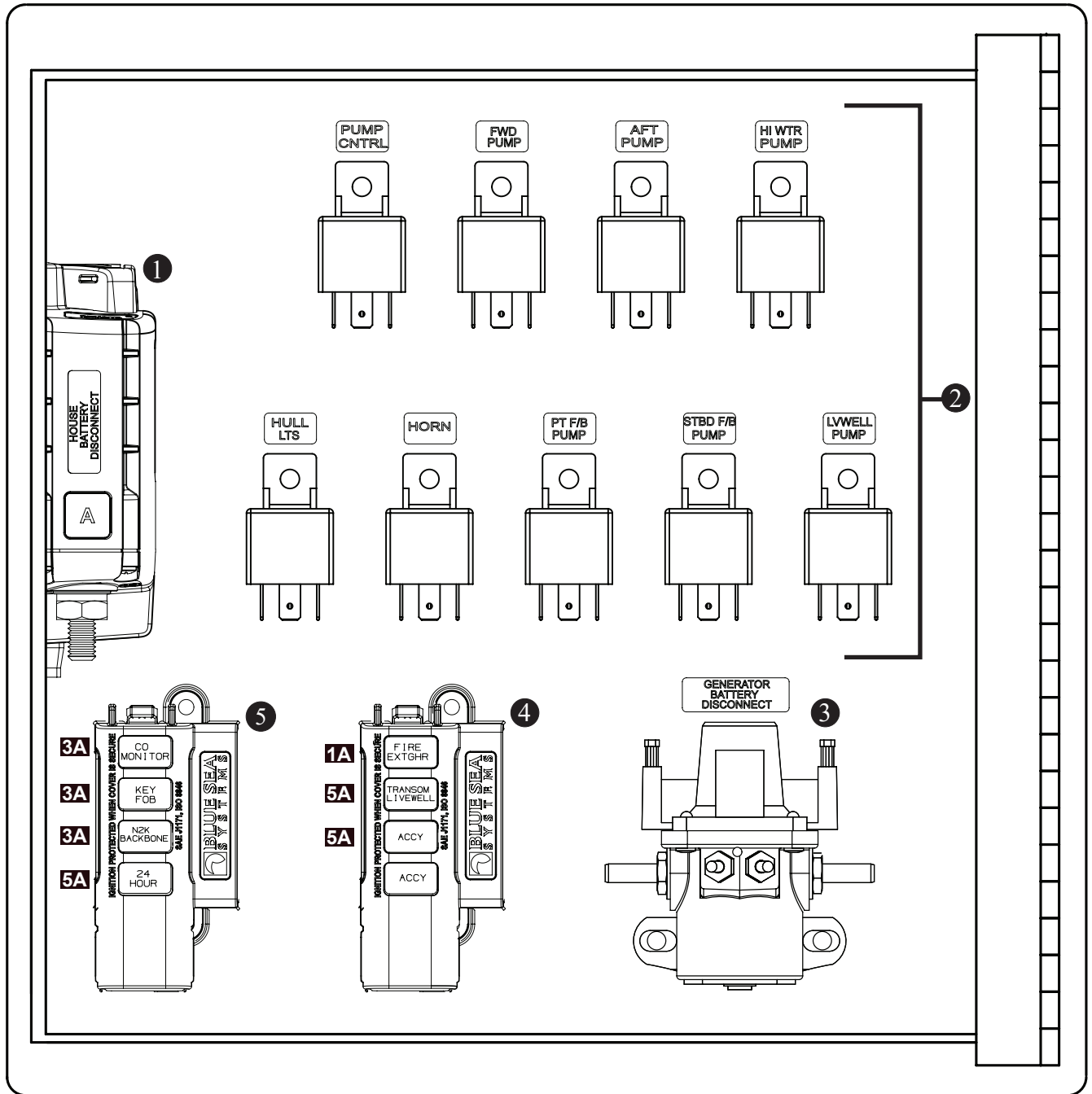

- 1 HOUSE REMOTE BATTERY SWITCH
- 2 RELAYS
- 3 GENERATOR BATTERY DISCONNECT

- 4 FUSE BLOCK
- 5 FUSE BLOCK

NOTE: This symbol **3A** indicates the specific amperage of the item shown (e.g., **5A** 5 amps)

Electrical Components

There are a variety of electronics located in the mid-berth that require minimal servicing except for fuse replacement (see Figure 4.12.1).

Electrical Components
Figure 4.12.1

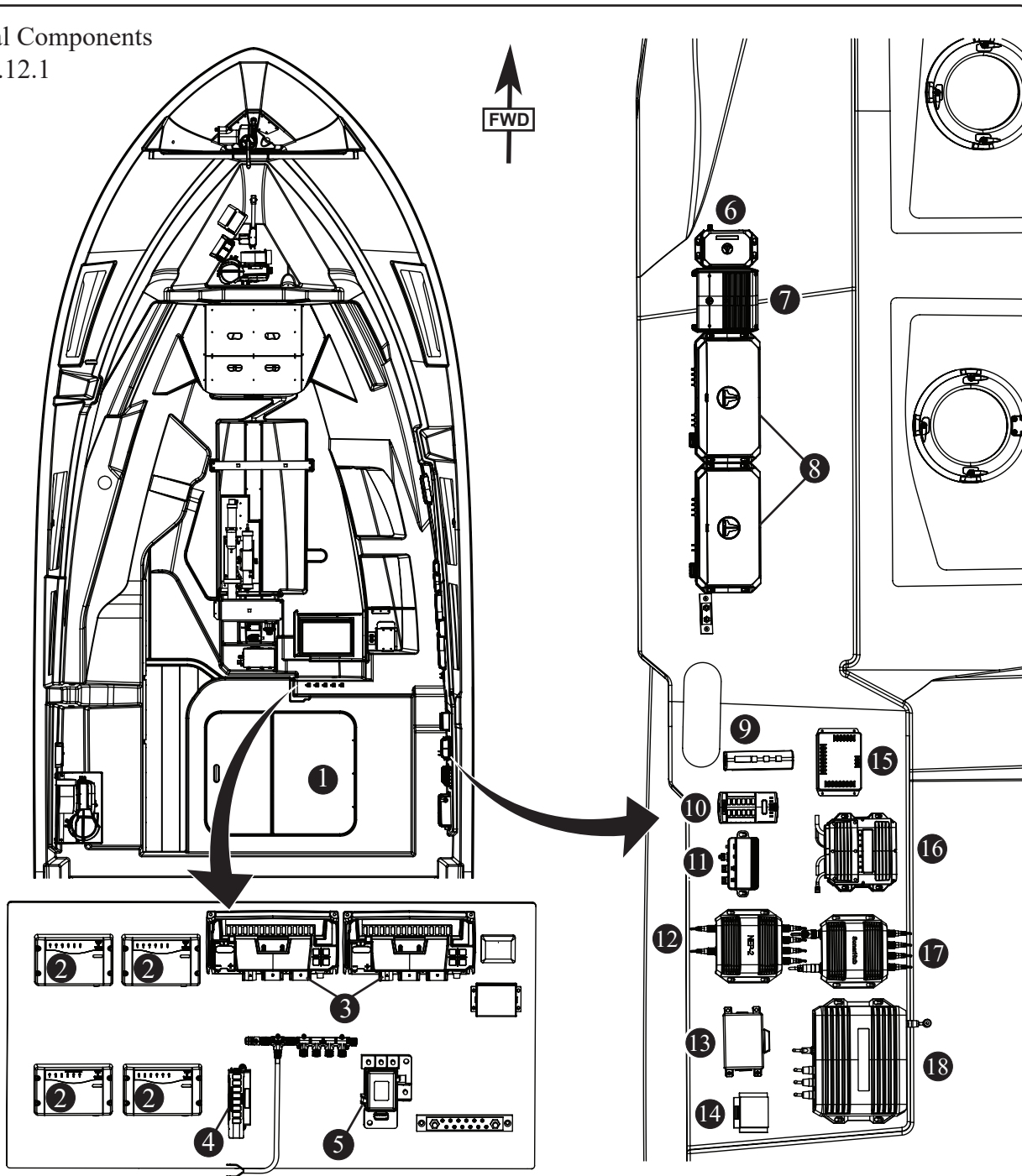

- | | | |
|-----------------------------|---------------------------|-----------------------------|
| 1 MID-BERTH | 7 STEREO AMP | 13 RGB MODULE |
| 2 CZONE MODULE | 8 STEREO AMP | 14 BILGE BLOWER CONTROLLER |
| 3 CZONE DISTRIBUTION MODULE | 9 STEREO AMPS FUSE BOX | 15 FIRE EXTINGUISHER SYSTEM |
| 4 CT-6 FUSE BLOCK | 10 ELECTRONICS FUSE BLOCK | 16 RADAR MODULE (OPTION) |
| 5 CABIN FUSE BLOCK | 11 SIRIUS (OPTION) | 17 DEPTH SOUNDER (OPTION) |
| 6 STEREO SERVER | 12 NETWORK HUB | 18 DEPTH SOUNDER (OPTION) |

Digital Switching

This vessel's digital switching system replaces traditional mechanical switches and circuit breakers with digital power distribution modules to provide monitoring and control of the electrical system. These modules are controlled from the helm displays, wireless remote, or switch panels, and are located throughout the boat. For the convenience of the operator, some switch functions duplicate those of mechanical switches.

Digital Switching Helm Display

Tap on the *Boston Whaler* app on the helm display to access digital switching screens (see Figure 4.13.1).

CAUTION

To maintain digital switching access, do not update software on navigation system or VesselView without first contacting a Boston Whaler dealer.

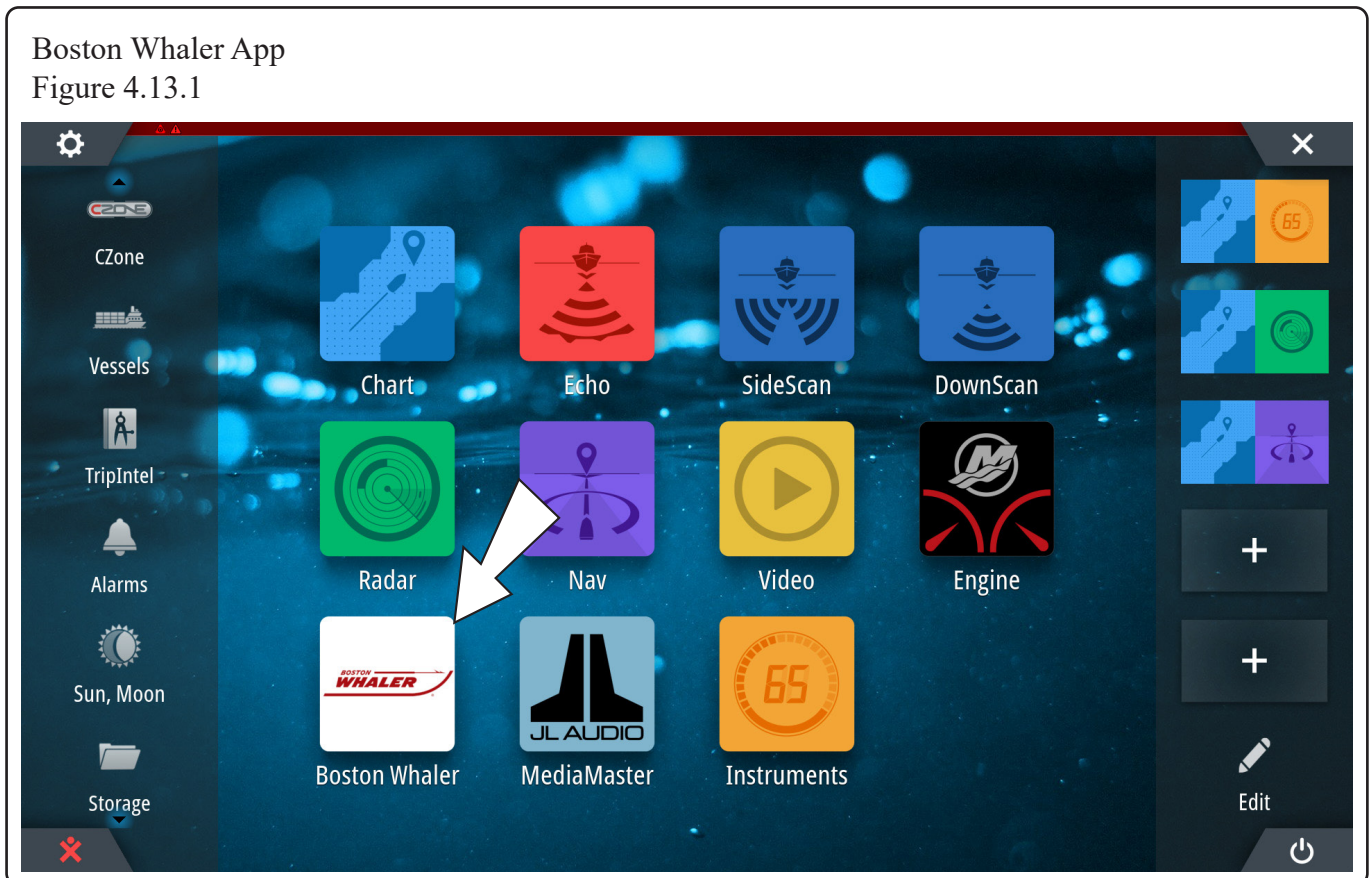

Digital Switching Tabs

Shown on the following pages are the four digital switching system tabs lighting, switches, A/C, and gauges. Switches are illuminated a specific color when selected. Green indicates *ON*, orange indicates *AUTO ON*.

Lighting Tab

Tap *LIGHTING* to monitor and control all exterior and interior lights and lighting modes.

Leaving the Boat

When preparing to leave the boat:

1. Turn off all engine battery switches on the *DC Distribution Panel* located in the cabin.
2. Tap the *MASTER OFF* switch on the *EXTERIOR LIGHTING* screen.

The *MASTER OFF* switch allows the user to shut down most of the lights and other components. Some lights and components if not already on, will turn on and remain on for two minutes allowing occupants to safely exit the boat. See the following list of effected lights and components.

Master Off Switch					
Function	Status		Function	Status	
Navigation lights	Off		Map lights (white)	On	Timer
Anchor light	Off		Midberth overhead lights	Off	
Mechanical access hatch lights	Off		Raw water pump	Off	
Deck courtesy lights	Off		Salon courtesy lights	Off	
Forward flood lights	Off		Salon overhead lights	On	Timer
Aft flood lights	On	Timer	Shade retract	On	Timer
Fresh water pump	Off		Underwater lights	Off	
Head courtesy & overhead lights	Off		Stateroom courtesy lights	Off	
House battery switch	On	Timer	Stateroom overhead lights	Off	
Hardtop overhead lights	Off		Stateroom reading lights	Off	
Map lights (red)	Off				

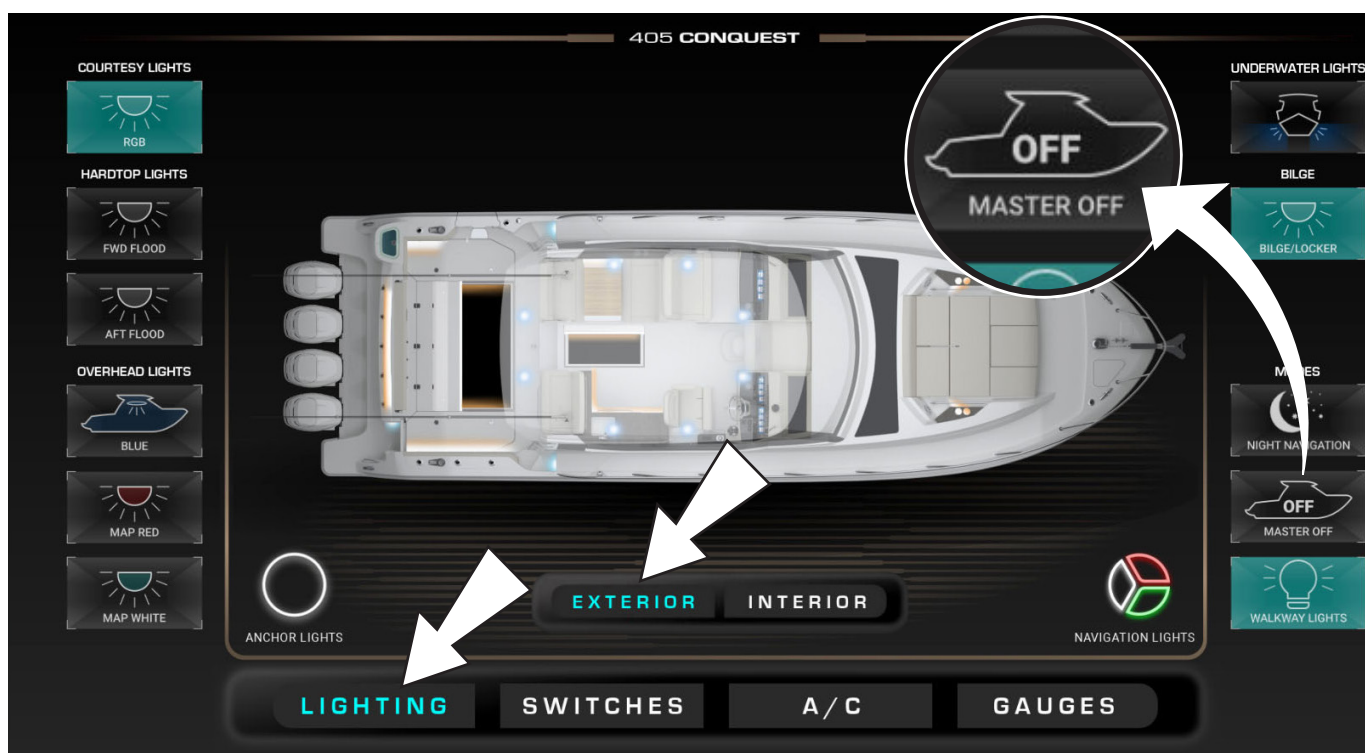

Switches Tab

Tap *SWITCHES* to control windshield wiper, washer, and defogger. The rear sun shade can be deployed or retracted and bilge pumps can be turned on, off, or set to automatic discharge. Raw and freshwater pumps can be turned on and off. All switches are illuminated green when turned on. Bilge pump switches illuminate orange when set to automatic.



A/C Tab

Tap *A/C* to monitor and control the air conditioners temperature and fan speed.

If a *NO CONNECTION TO A/C UNIT* message appears at the bottom of the screen, check that A/C and A/C pump breakers are turned on and the generator or shore power is supplying AC power to the boat.



Gauges Tab

Tap *GAUGES* to monitor fluid and power levels.

Tap *FLUIDS* to monitor freshwater, waste, and fuel.

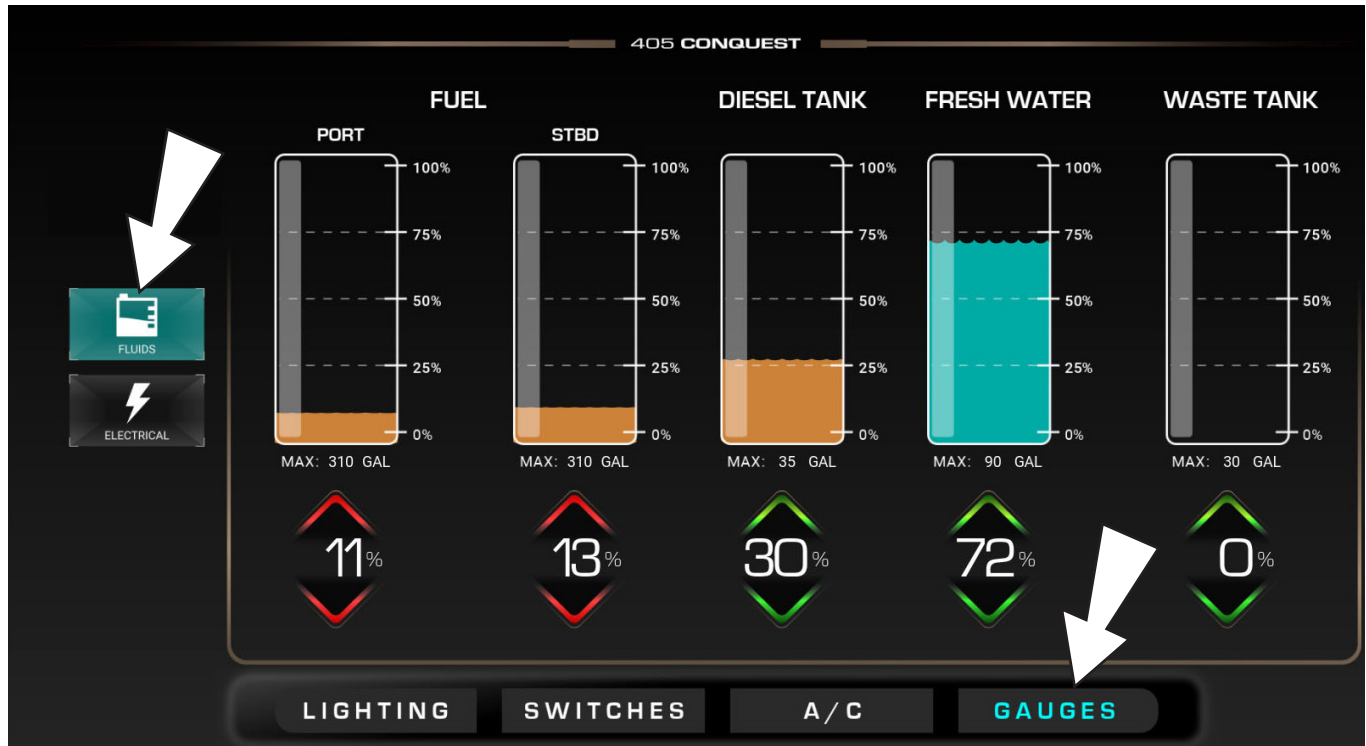

Tap *ELECTRICAL* to monitor voltage on the generator, shore power, and batteries*.

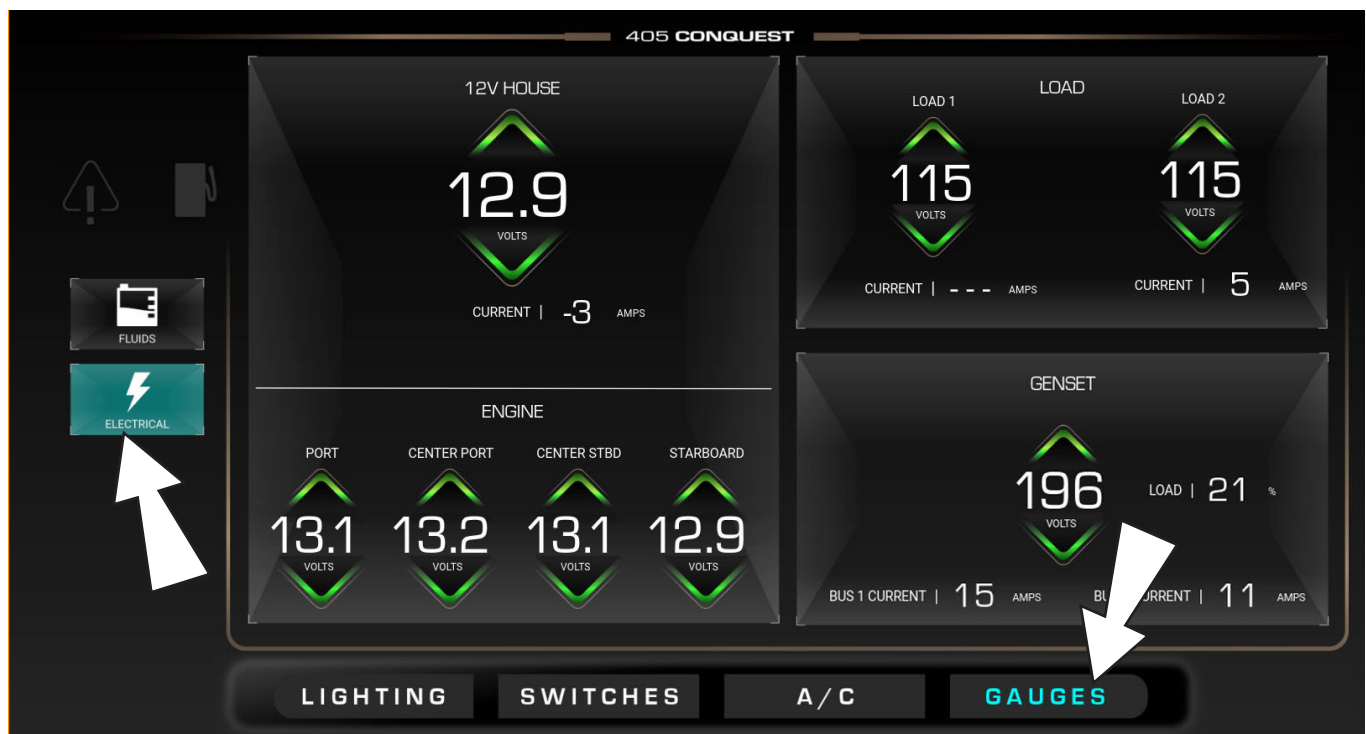

*NOTE: Electrical tab content may vary depending on options.

Alarms

If any of the electrical systems fail, a warning symbol appears on the upper right side of the *LIGHTING*, *SWITCHES*, or *A/C* screen. Tap on the warning symbol to access the *ALARM PAGE*.



DANGER

Never ignore an alarm.



When accessing the *ALARM PAGE* tap *DIAGNOSTIC* to see component status. A green *STATUS* light indicates *FUNCTIONS* operating properly. A red *STATUS* light indicates *FUNCTIONS* requiring attention.

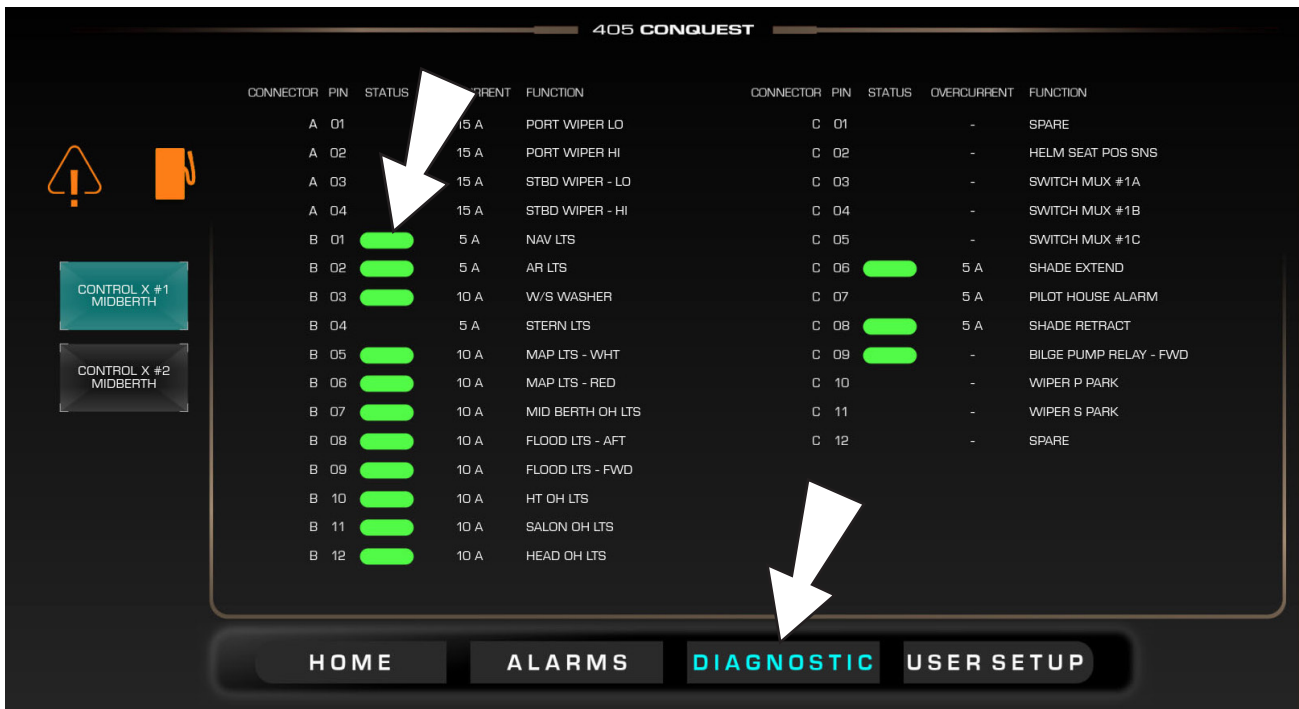

Silence Alarm

If an alarm sounds, silence it by tapping anywhere in the center field on the *ALARMS* tab screen. The specific issue that triggered the alarm will be listed in the center field. Click on the *DIAGNOSTIC* tab for additional status information.

For further information, contact a Boston Whaler dealer or Boston Whaler customer service.

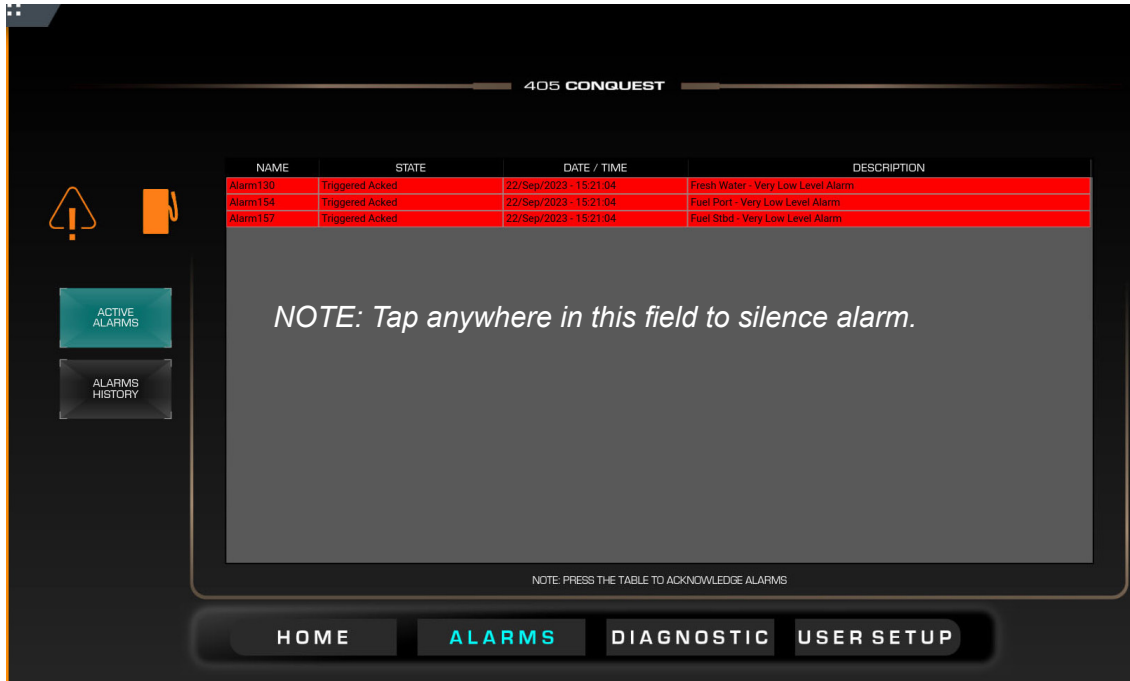

User Setup

To choose a preferred unit of measure tap on the *USER SETUP* button, accessible from the *ALARM* or *DIAGNOSTIC* screens.

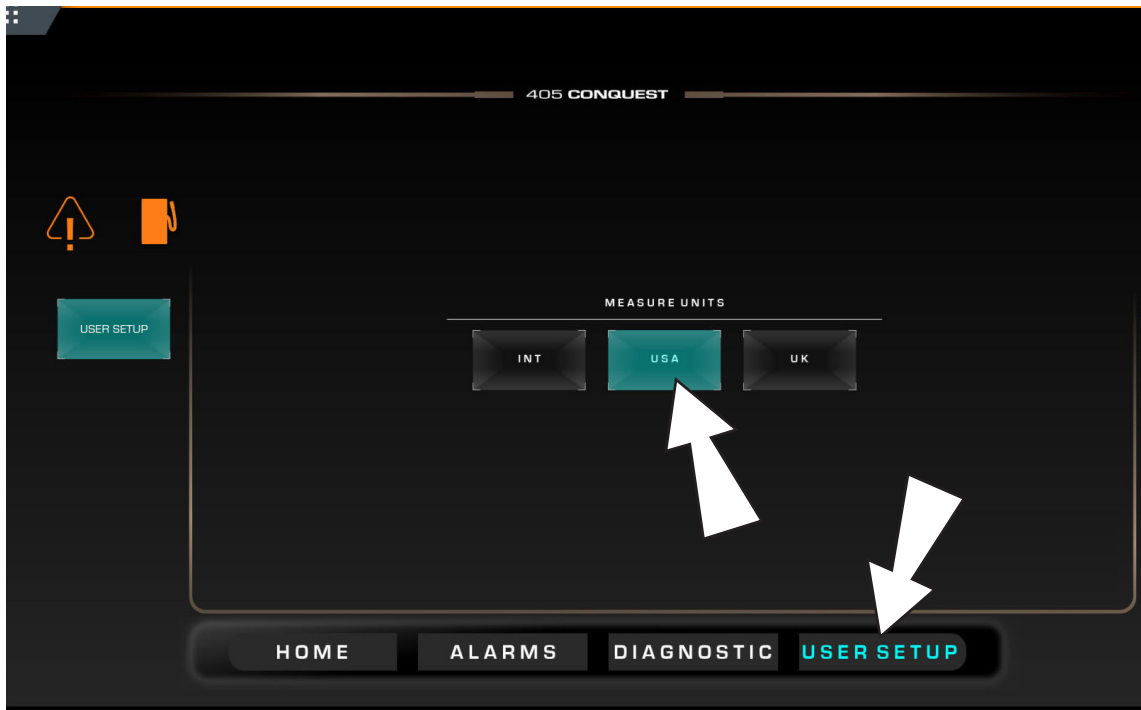

Low Fuel

When the fuel level runs low, a fuel pump symbol appears in the upper right corner of the *LIGHTING*, *SWITCHES* or *A/C* screen indicating low fuel. Tap on the symbol to be transferred to the *FLUIDS* display to view the fuel tank level.

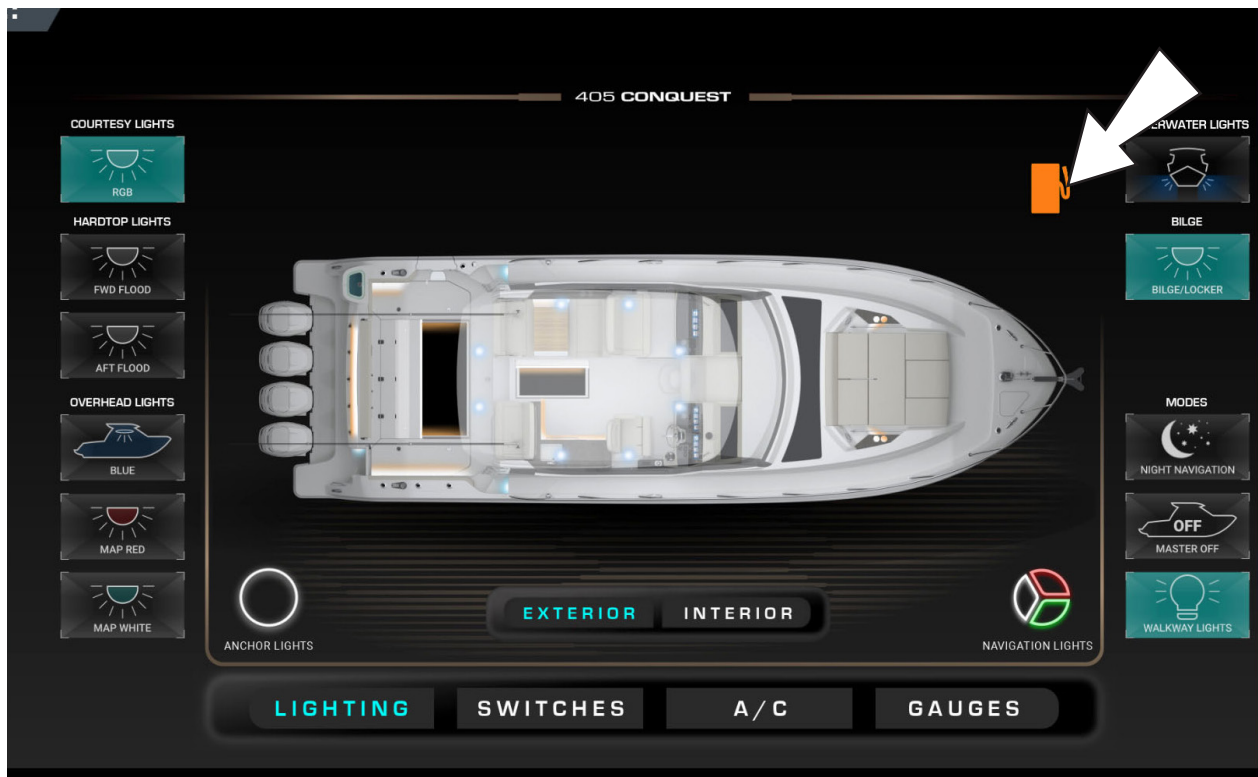

CZone Wireless Remote

The wireless remote control key fob (see Figure 4.19.1) allows operation of four different functions from a distance of up to 250 feet (80 meters).

CZone Wireless Remote Key Fob
(FIGURE 4.19.1)

- 1 HOUSE BATTERY SWITCH ON*
- 2 HARDTOP OVERHEAD LIGHTS ON/OFF
- 3 SALON/GALLEY OVERHEAD LIGHTS ON/OFF
- 4 DECK COURTESY/RGB LIGHTS ON/OFF

*Switch does not turn house battery off.



CZone Modules

CZone modules and distribution modules provide control, monitoring, and device management for circuits throughout the boat. The modules (see Figure 4.20.1) are located behind panels in the mid-berth (see *Electrical Components* earlier in this chapter).

CZone Modules
(FIGURE 4.20.1)

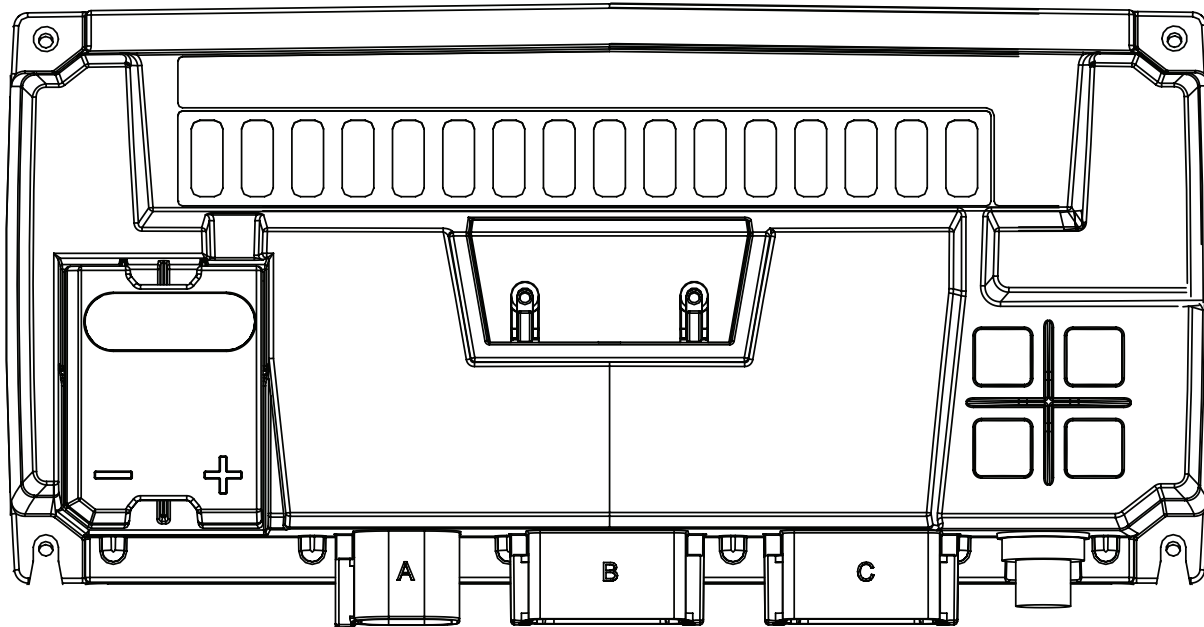
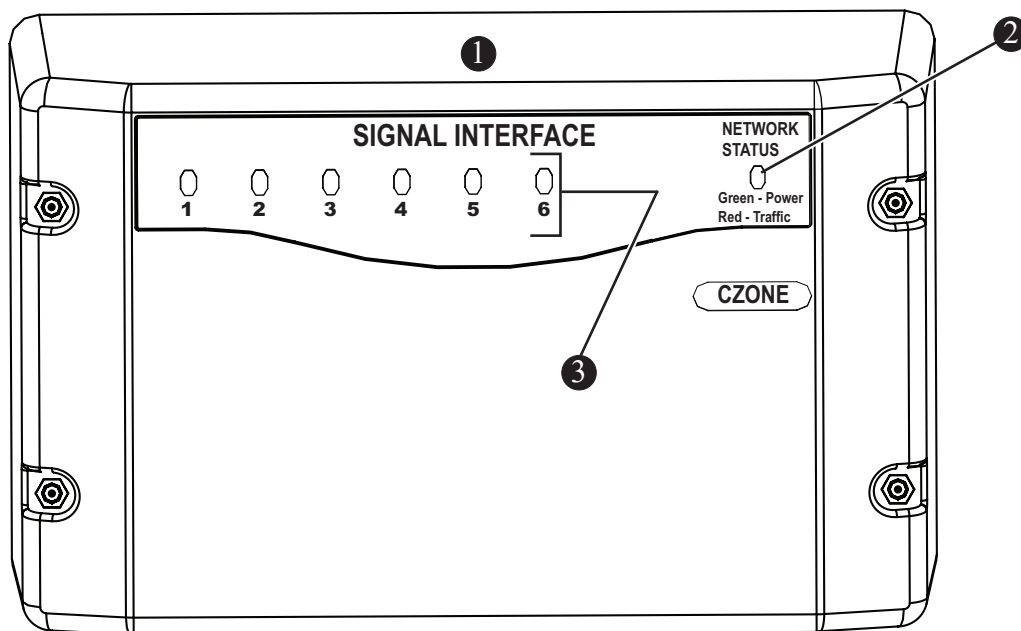

- | | |
|---------------------------------|---------------------------------|
| 1 CZONE MODULE | 3 CHANNEL STATUS INDICATORS (6) |
| 2 CHANNEL STATUS INDICATORS (6) | 4 CZONE DISTRIBUTION MODULE |

NOTE: Illustration may not be representative of CZone modules installed in this vessel.

Transducer

The transducer acts as an antenna for the sonar system, sending sound waves through the water, bouncing off objects, and returning a signal to the boat. Should after market installation be required, contact a Boston Whaler dealer for more information (see Figure 4.21.1).

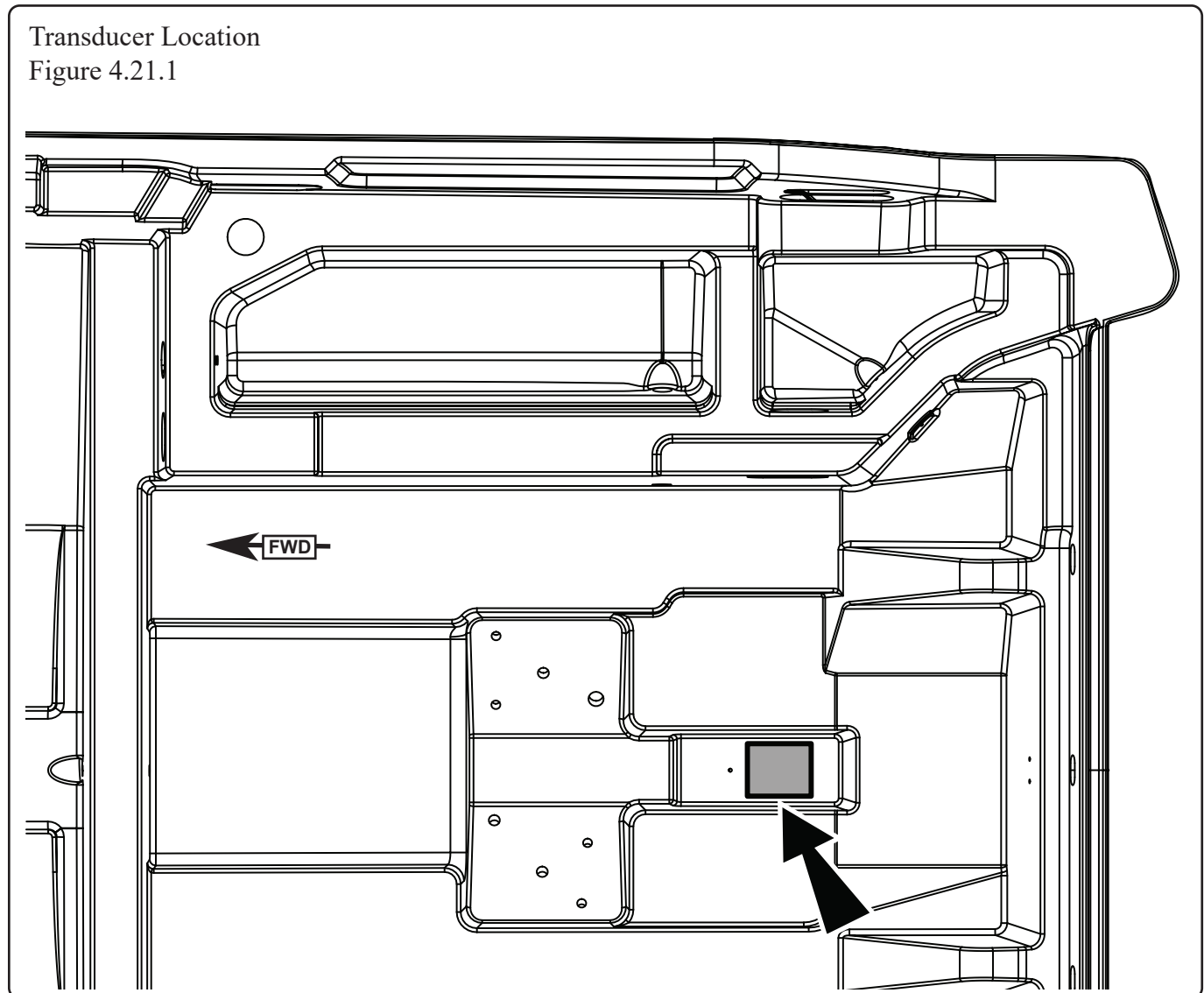

Rigging Pulls

Factory-installed rigging pulls are provided to assist with the routing of new wiring. This vessel is equipped with multiple rigging pulls tied off at either end of the rigging tube (see Figure 4.22.1). When using a rigging pull, be sure to attach a cord to each run of the new wiring to ensure a new pull is in place for future use. Ensure the foam plug surrounding the rigging pull in the tubing is reinstalled or replaced to create a complete seal. Use an expanding spray foam if necessary. Failure to reseal the rigging tube completely could result in an explosion or carbon monoxide inhalation. For further information on rigging pulls, contact your dealer or Boston Whaler.

⚠ DANGER

Rigging tube must be sealed once the plug has been removed.

Rigging
Figure 4.22.1

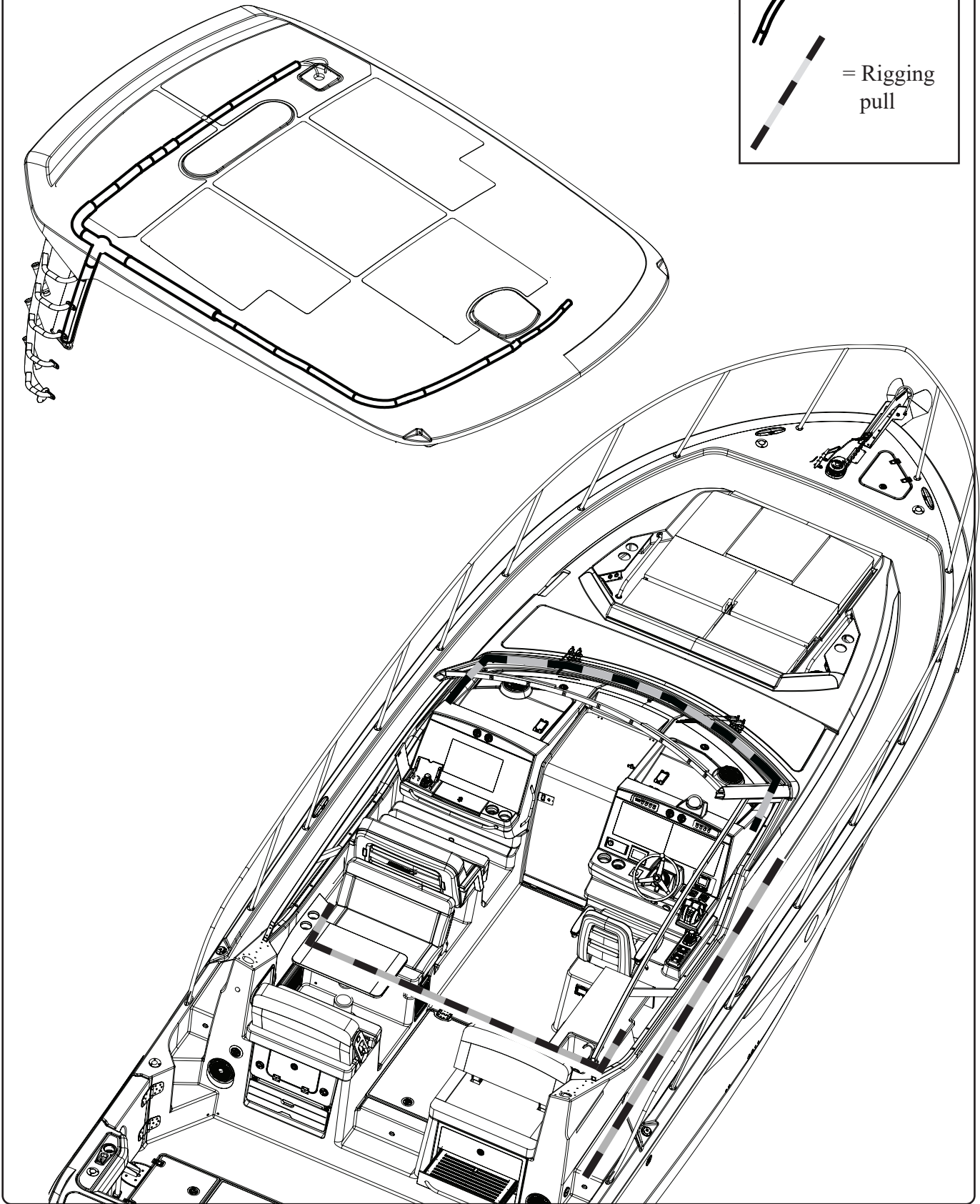
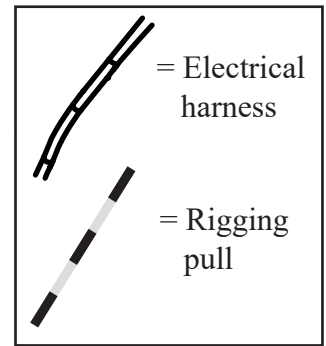

DC Quad Engine
(FIGURE 4.24.1)

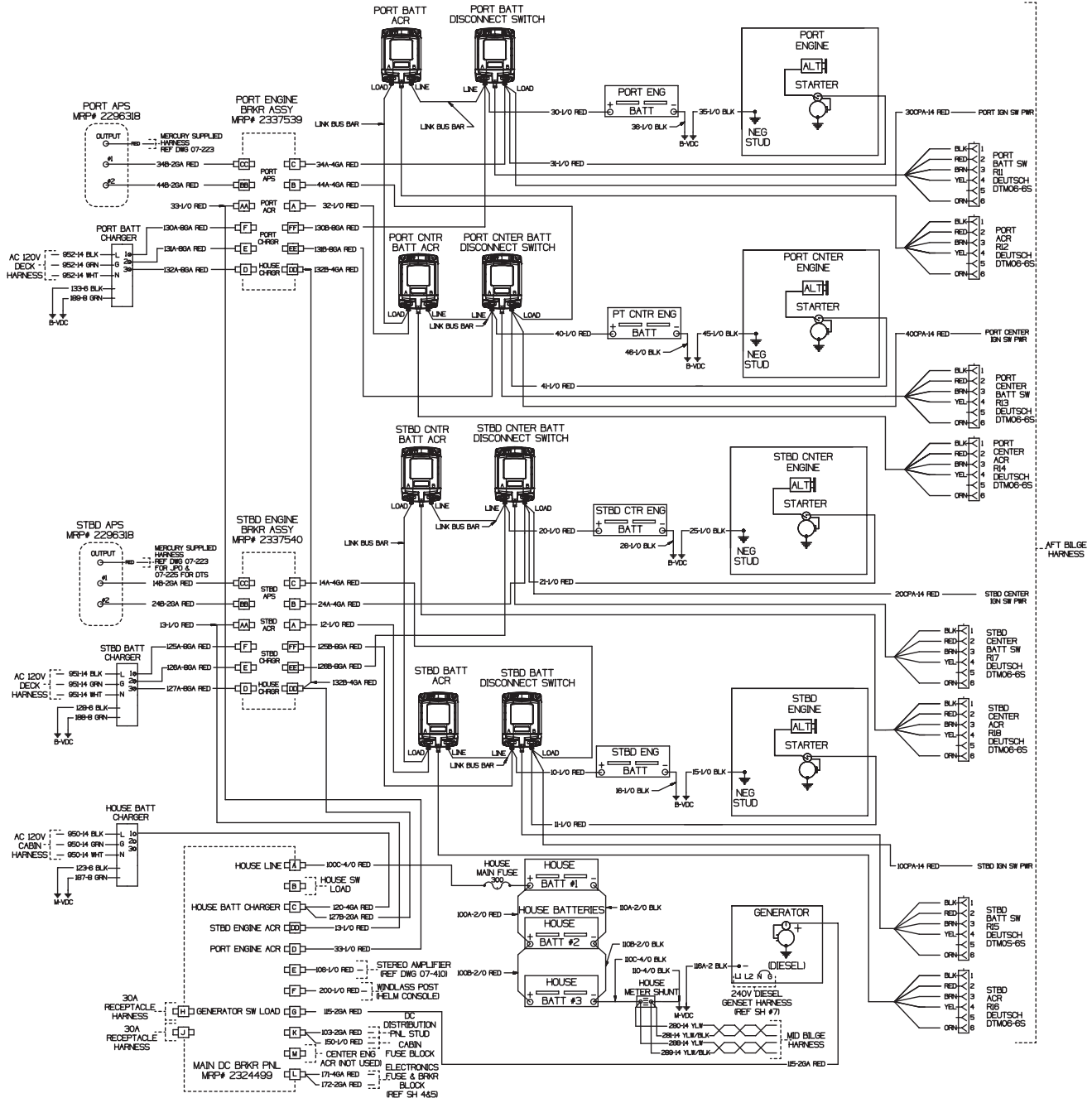

6029-07-401_2_I

Chapter 4 • Electrical

DC Harness and Panel
(FIGURE 4.25.1)

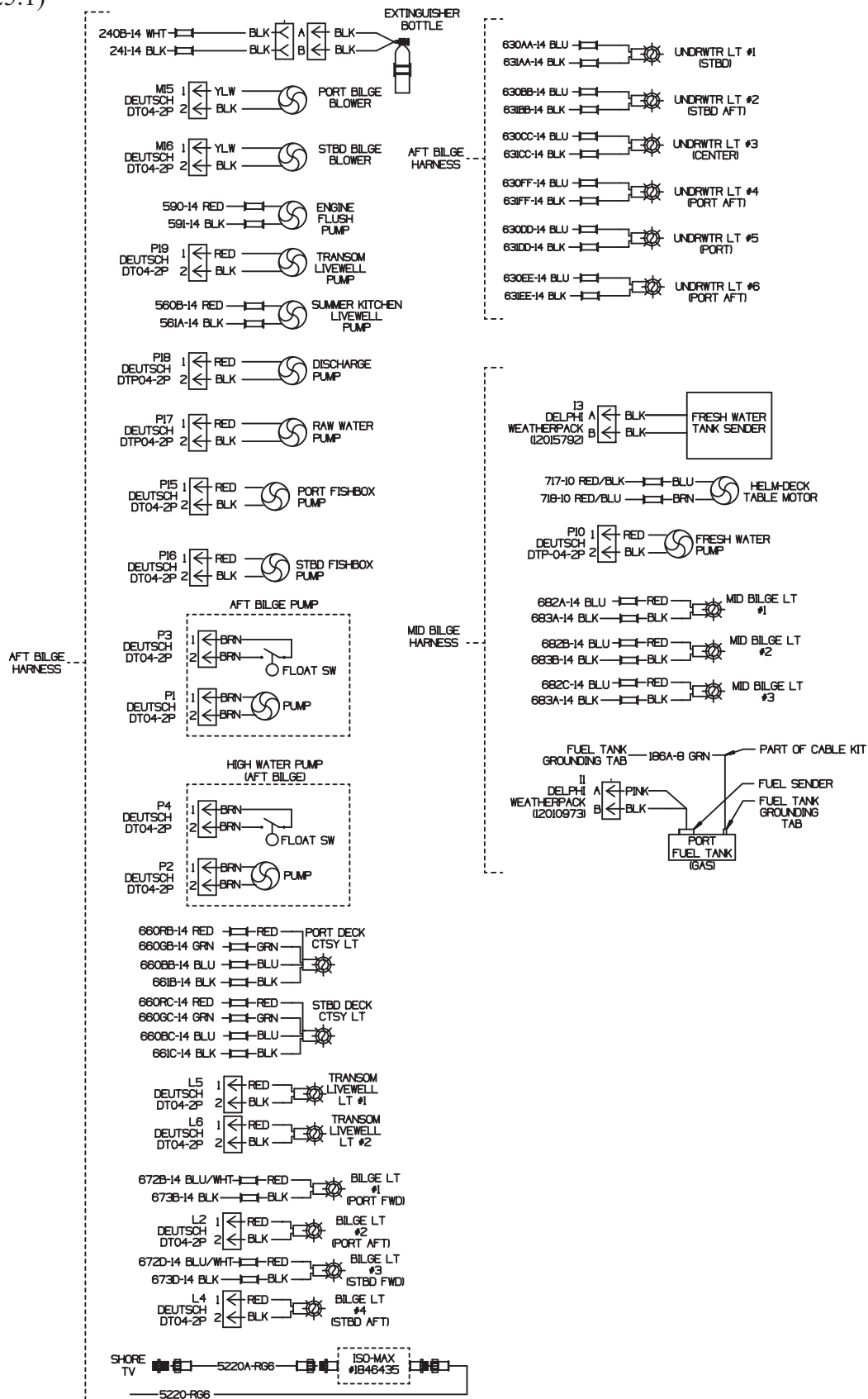

6029-07-401_3_I

DC Harness and Panel
(FIGURE 4.26.1)

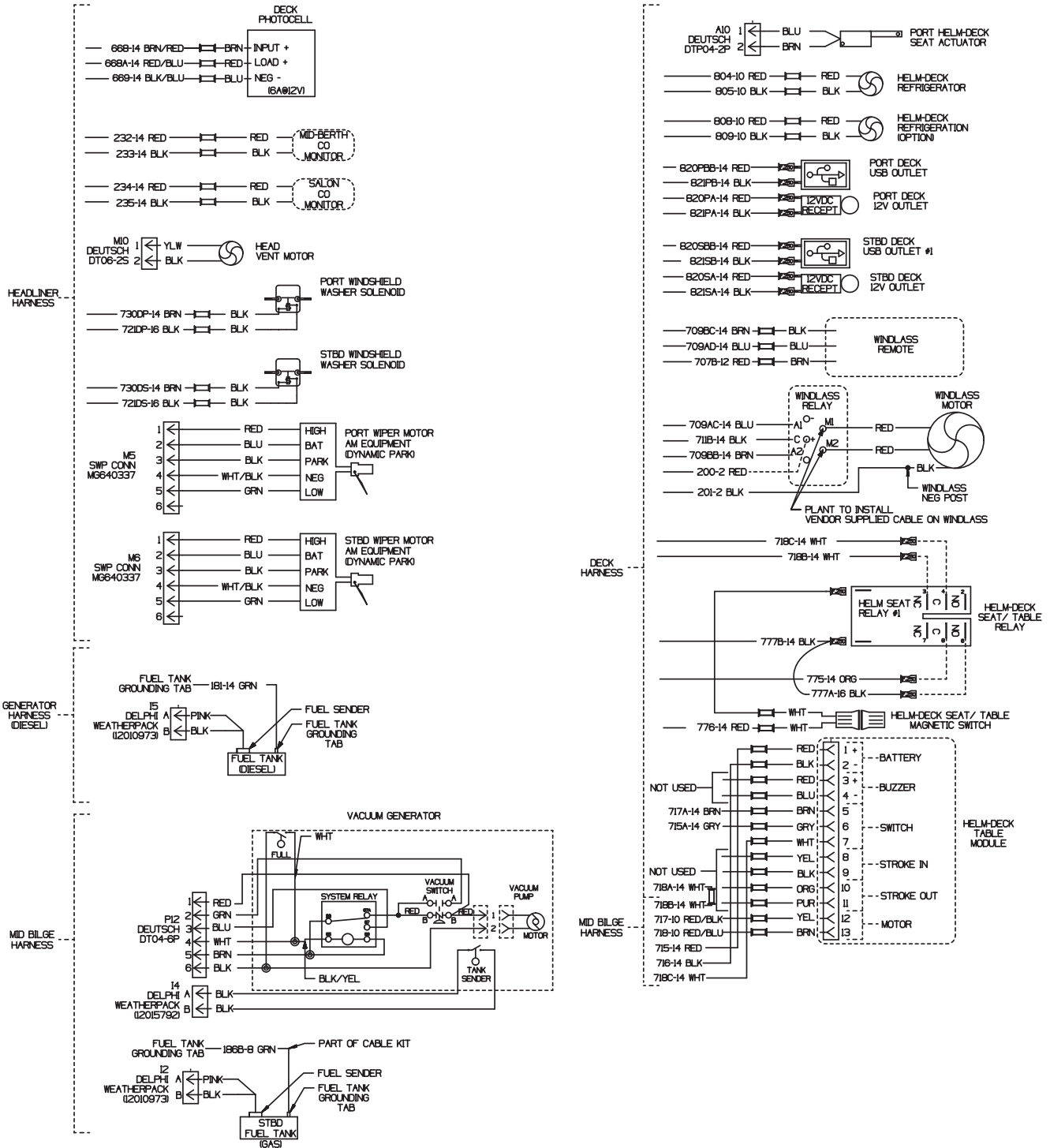

6029-07-401_3_I

DC Harness and Panel
(FIGURE 4.27.1)

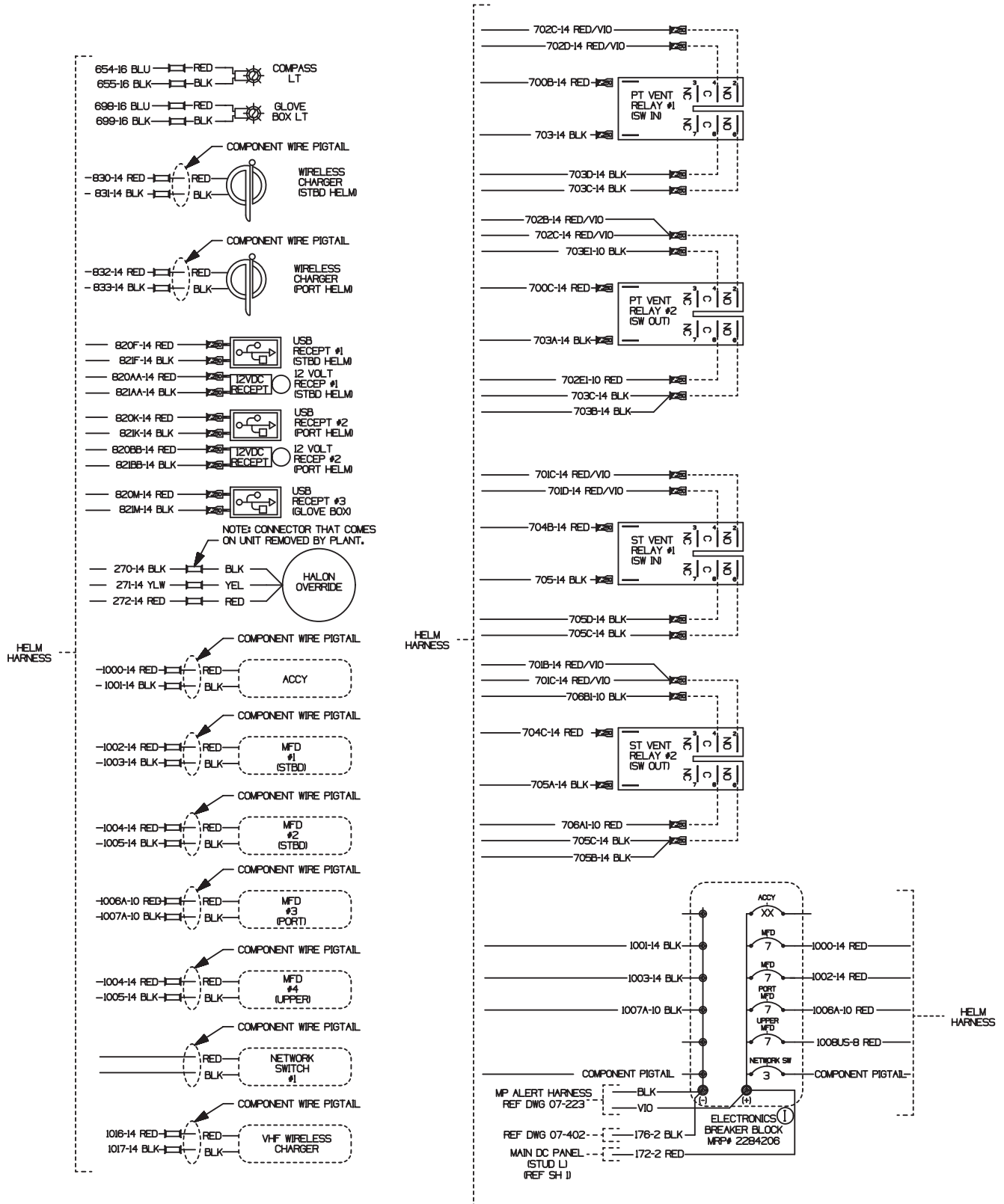

6029-07-401_4_I

Chapter 4 • Electrical

DC Harness and Panel
(FIGURE 4.28.1)

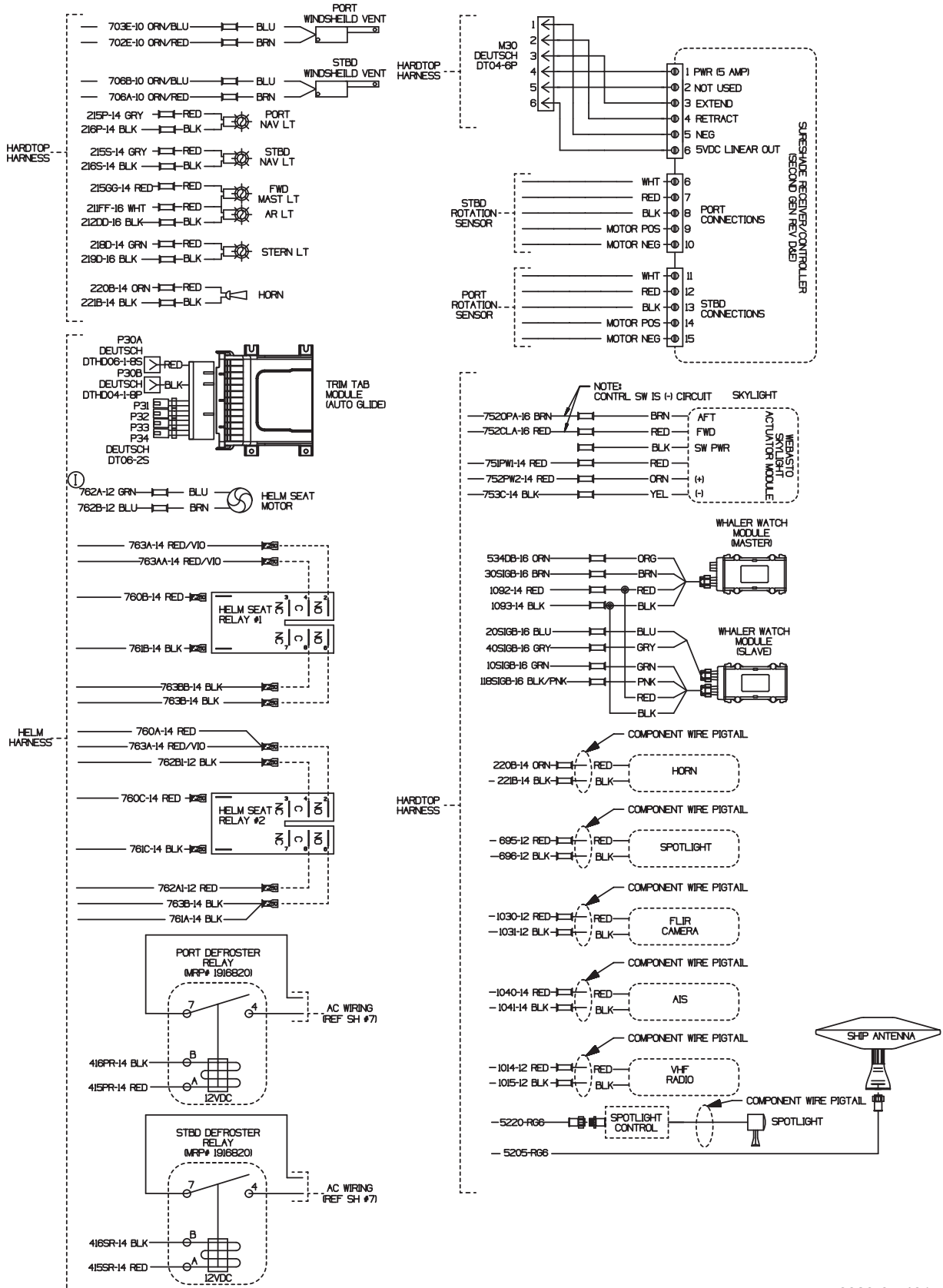

6029-07-401_4_I

Chapter 4 • Electrical

DC Harness and Panel
(FIGURE 4.29.1)

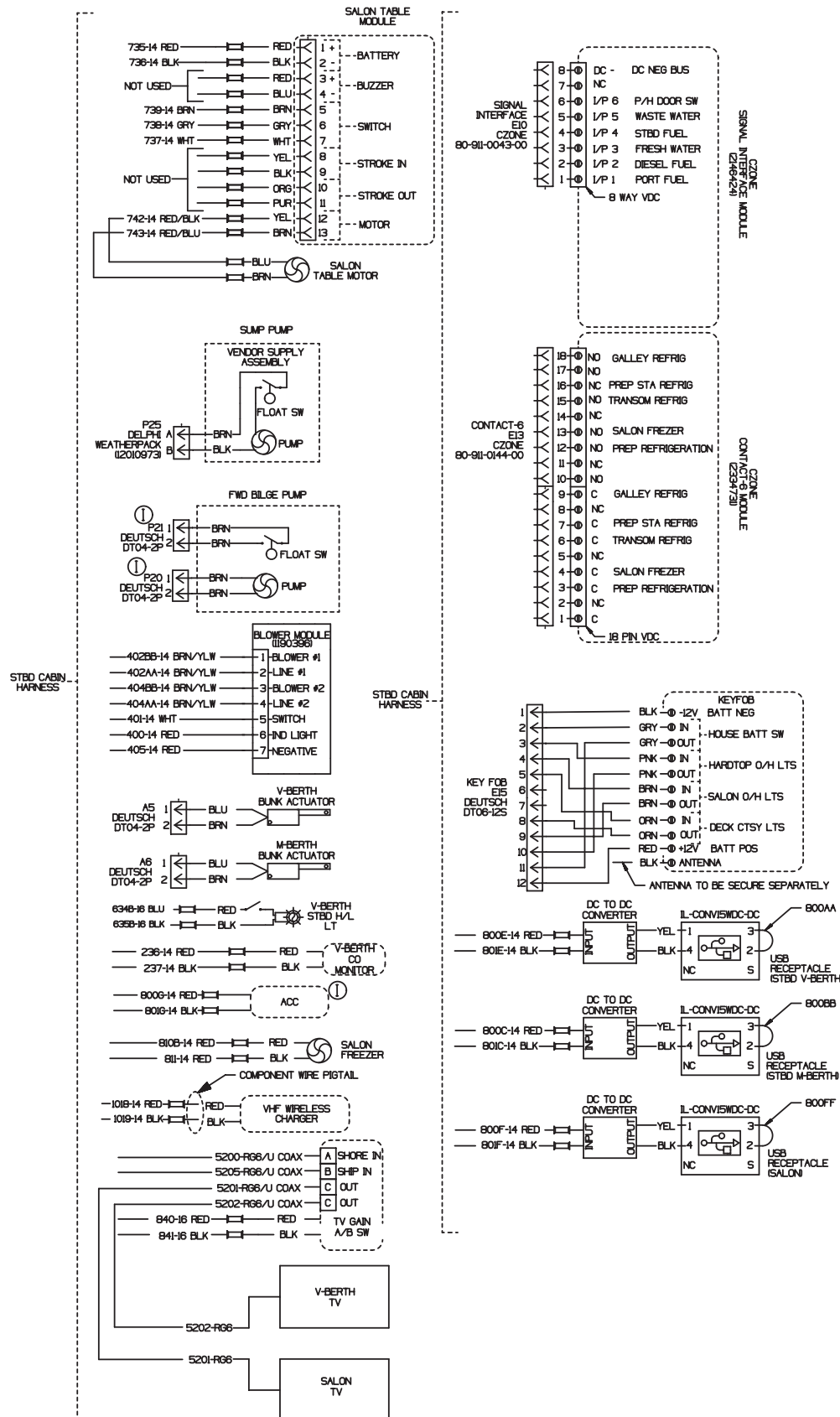

6029-07-401_5_I

DC Harness and Panel
(FIGURE 4.30.1)

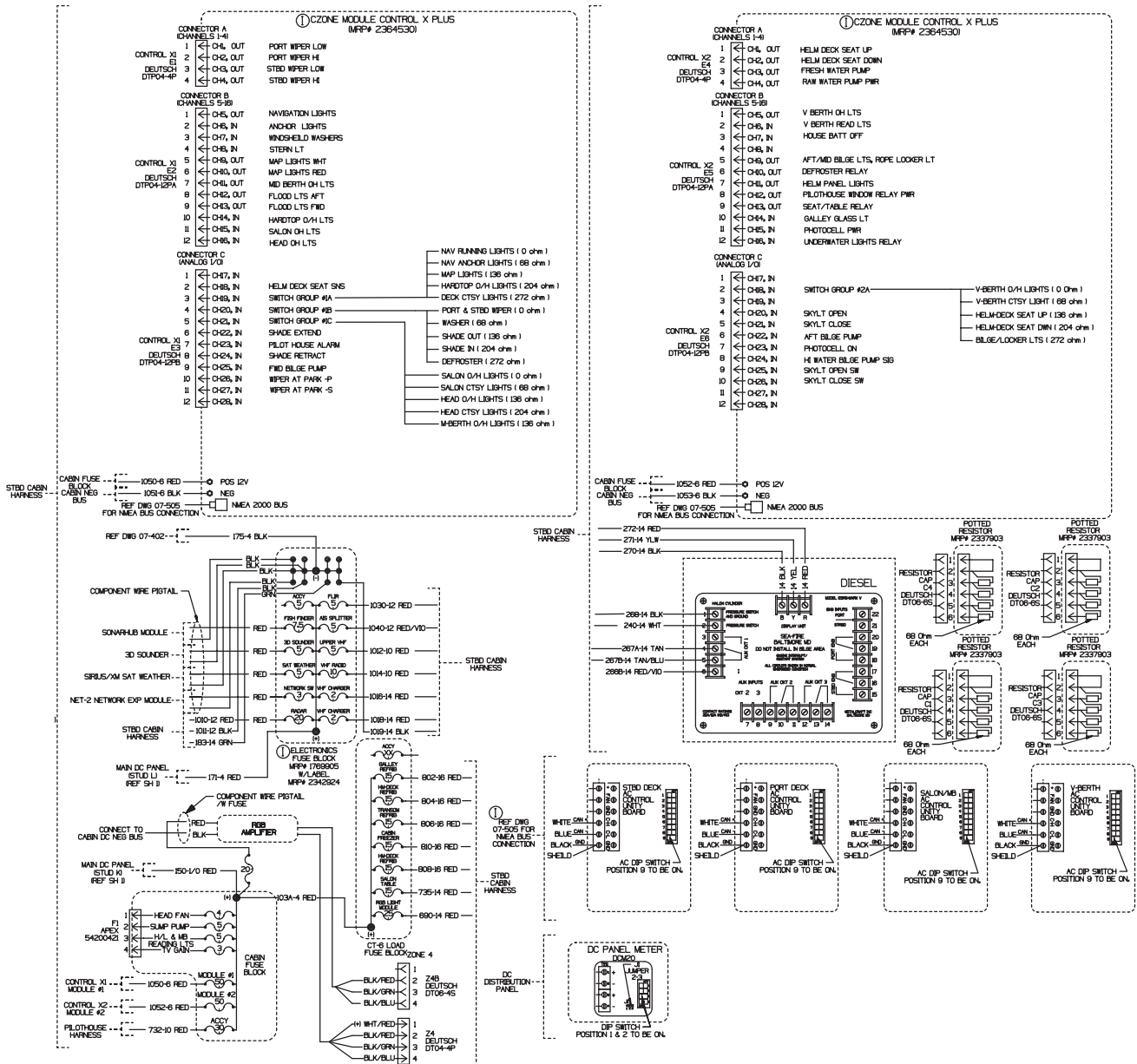

Chapter 4 • Electrical

DC Harness and Panel
(FIGURE 4.31.1)

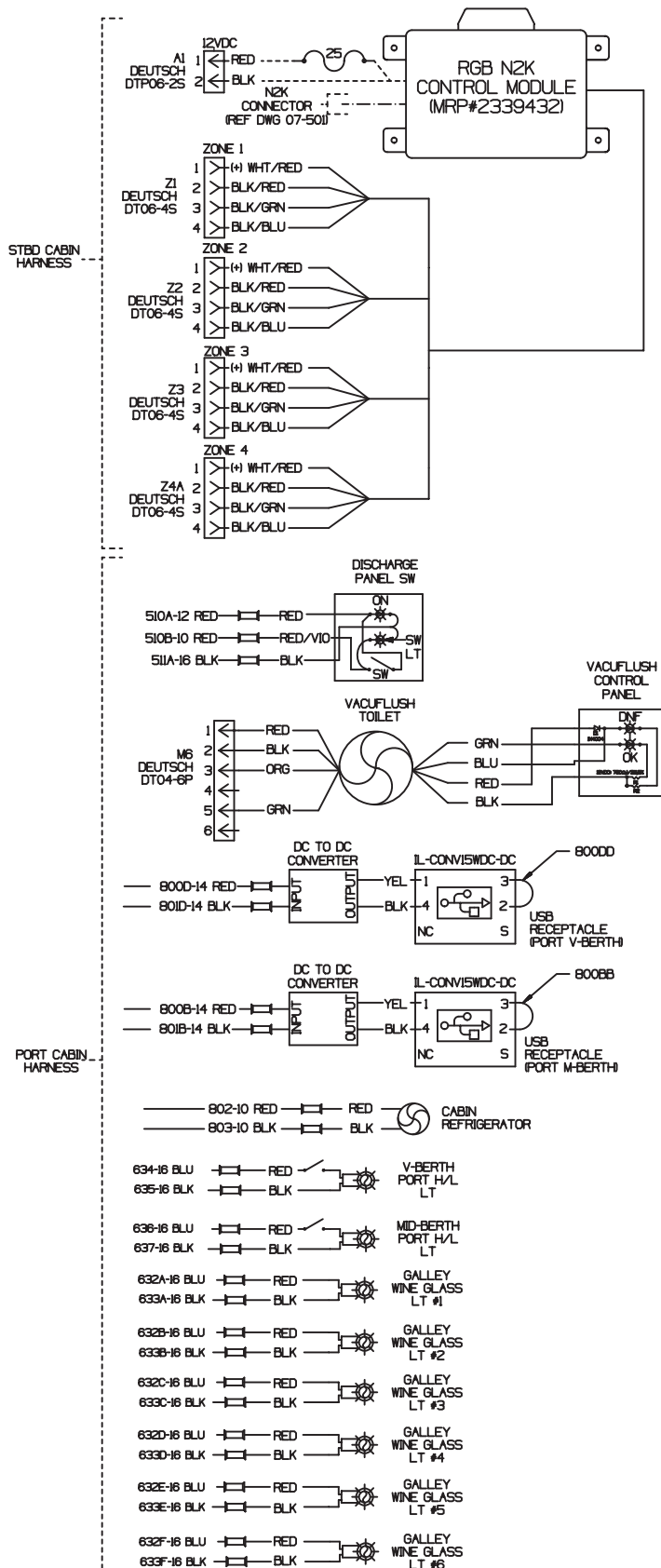

6029-07-401_6_I

DC Harness and Panel
(FIGURE 4.32.1)

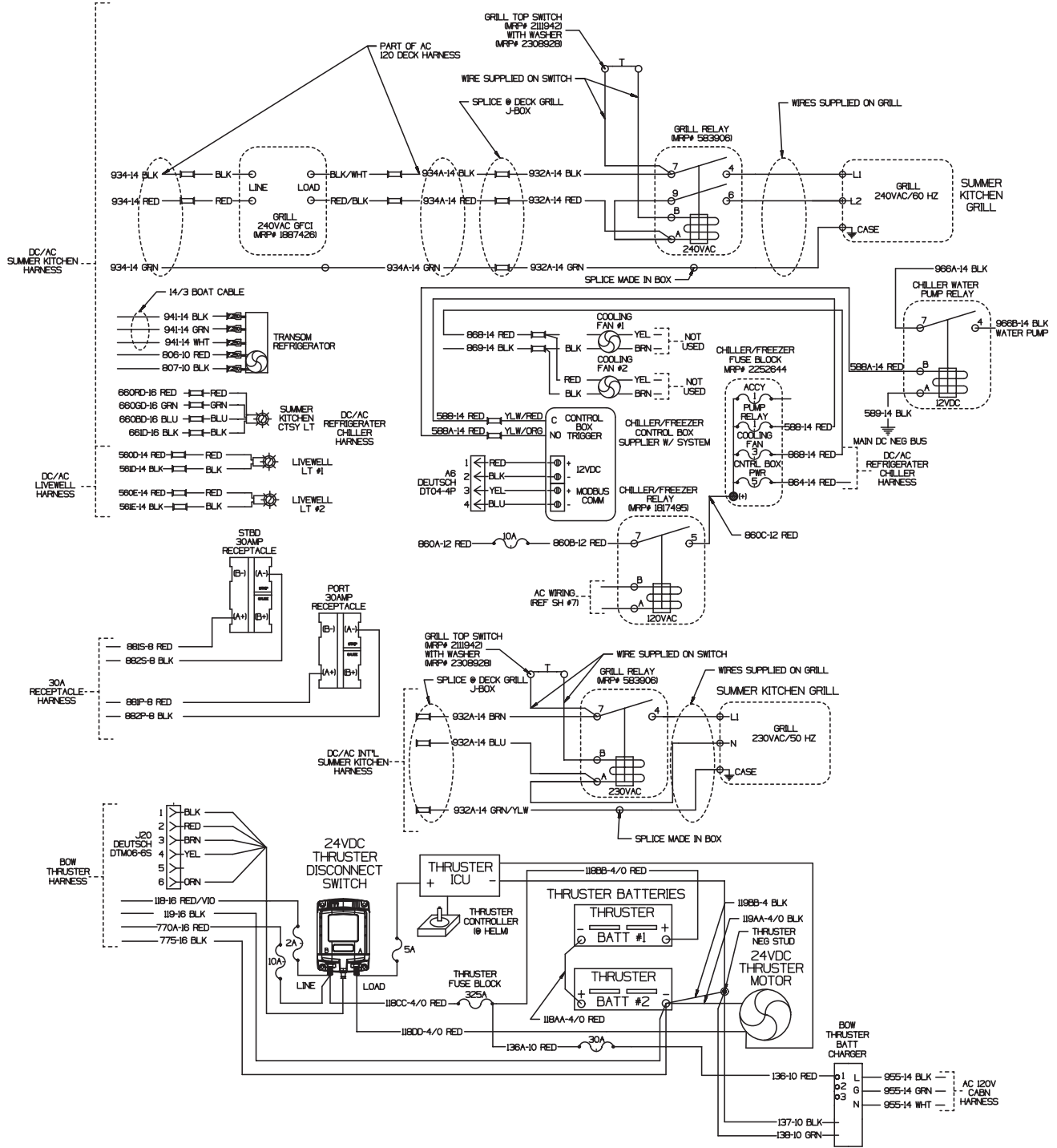

6029-07-401_6_I

Chapter 4 • Electrical

DC Harness and Panel
(Figure 4.33.1)

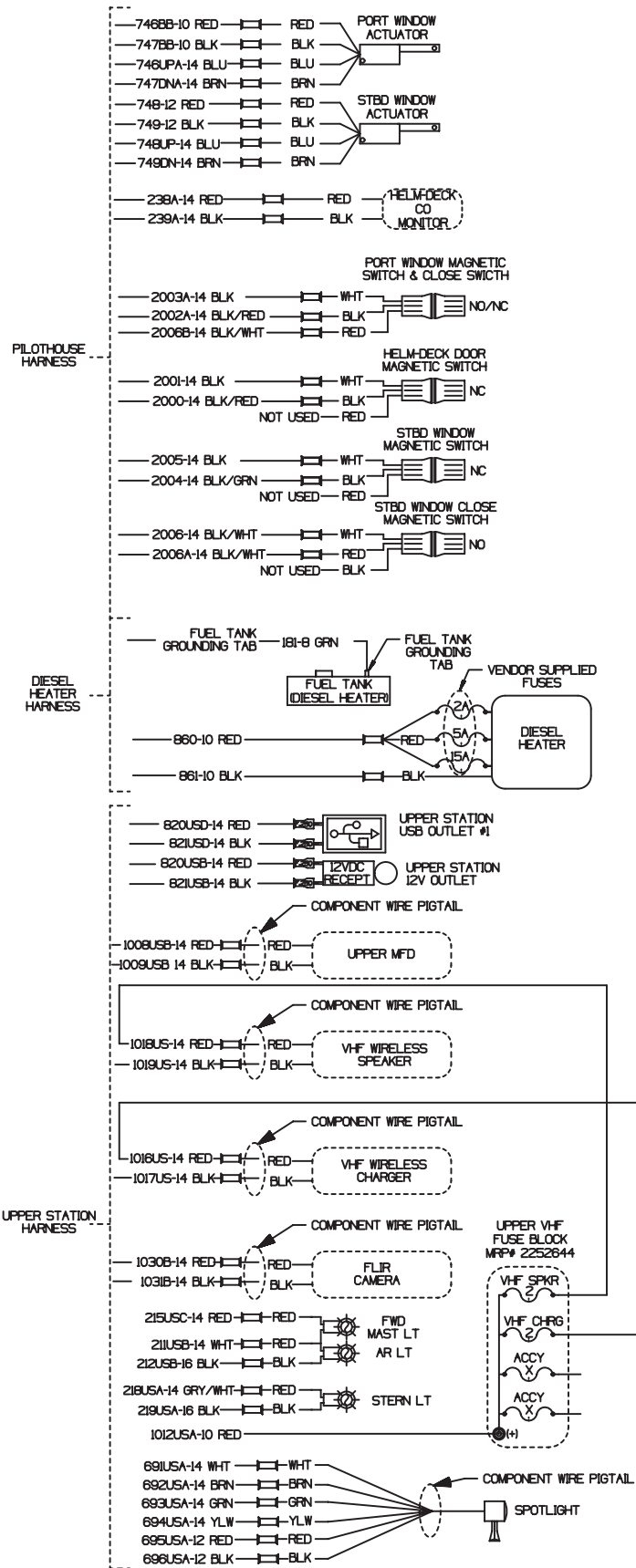

6029-07-401_6_I

AC Harness and Panel
(Figure 4.34.1)

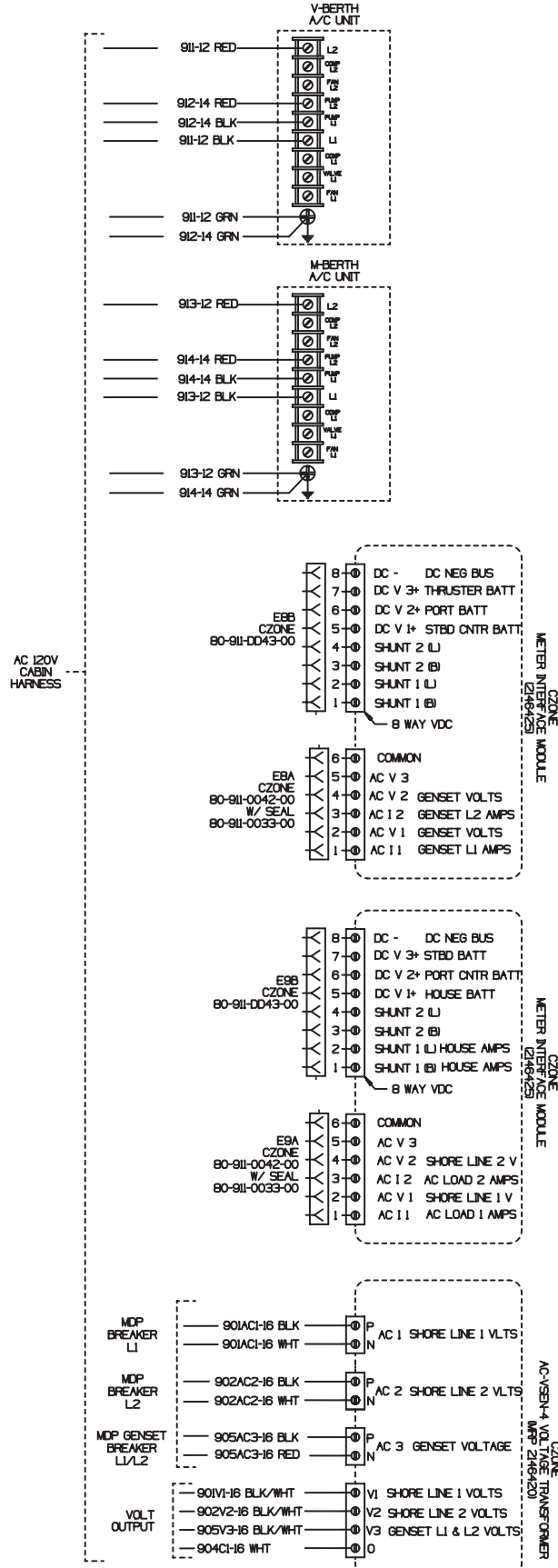

6029-07-401_7_1

Chapter 4 • Electrical

AC Harness and Panel
(FIGURE 4.35.1)

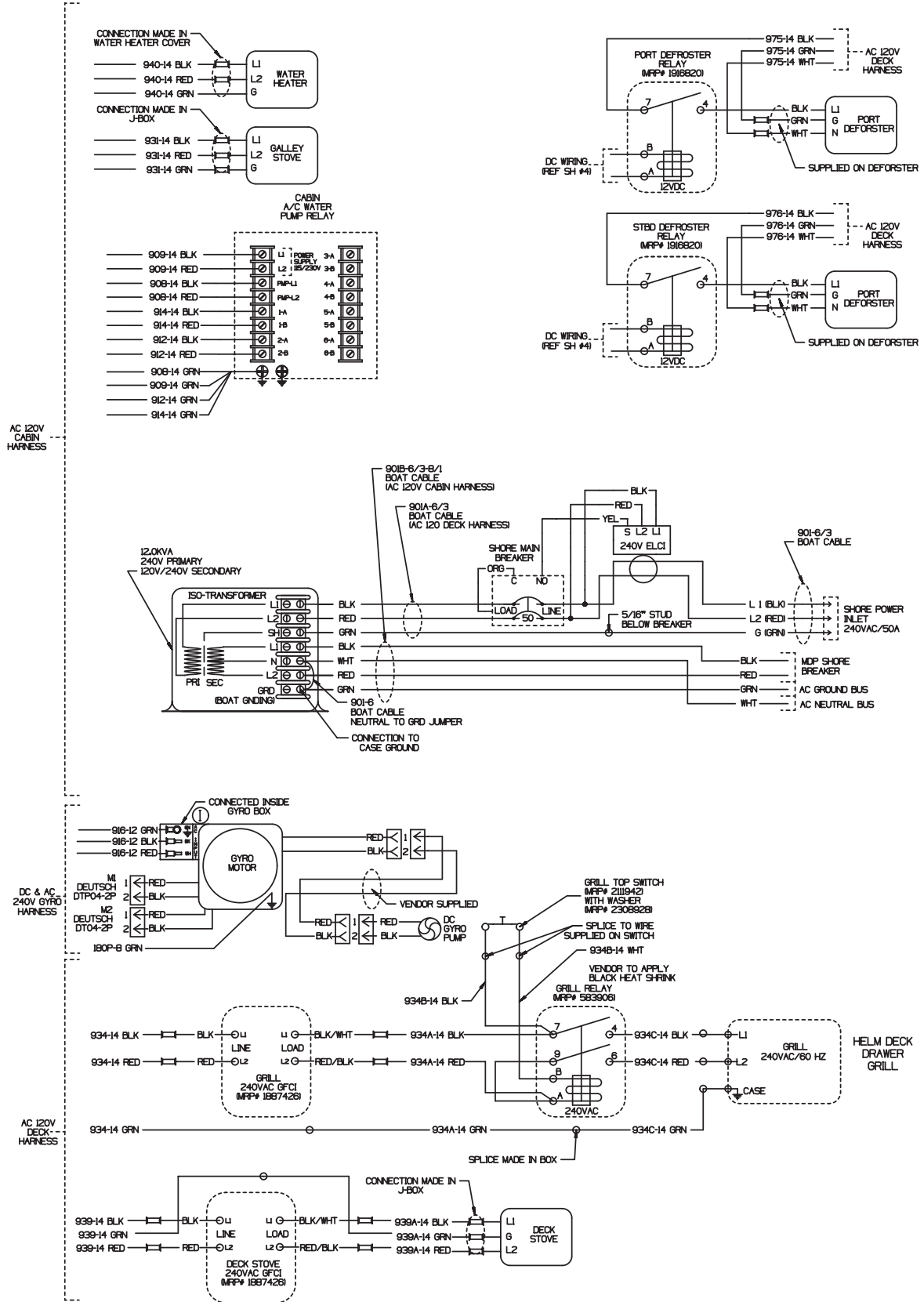

6029-07-401_7_I

AC Harness and Panel
(FIGURE 4.36.1)

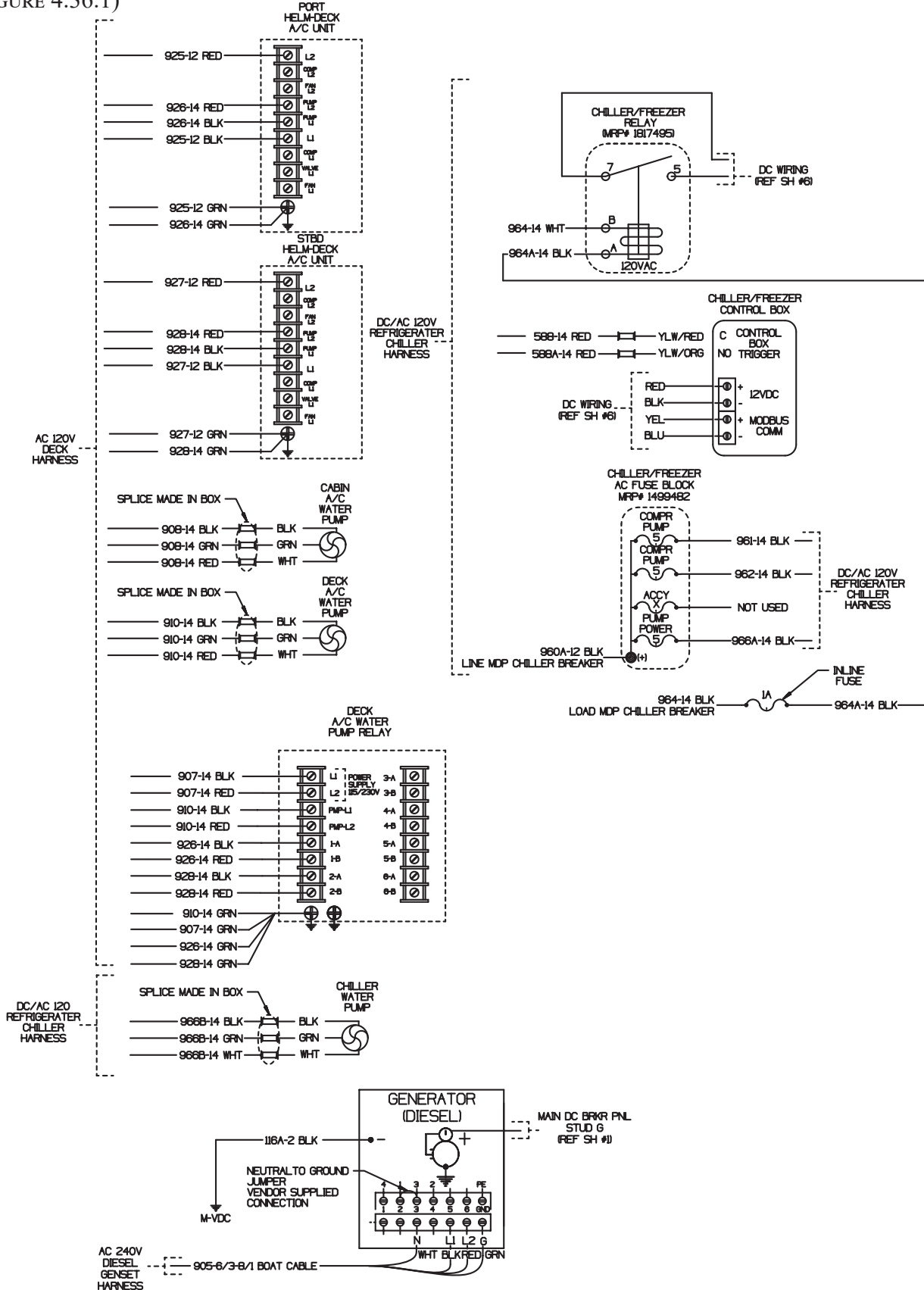

6029-07-401_7_I

AC Harness and Panel
(FIGURE 4.37.1)

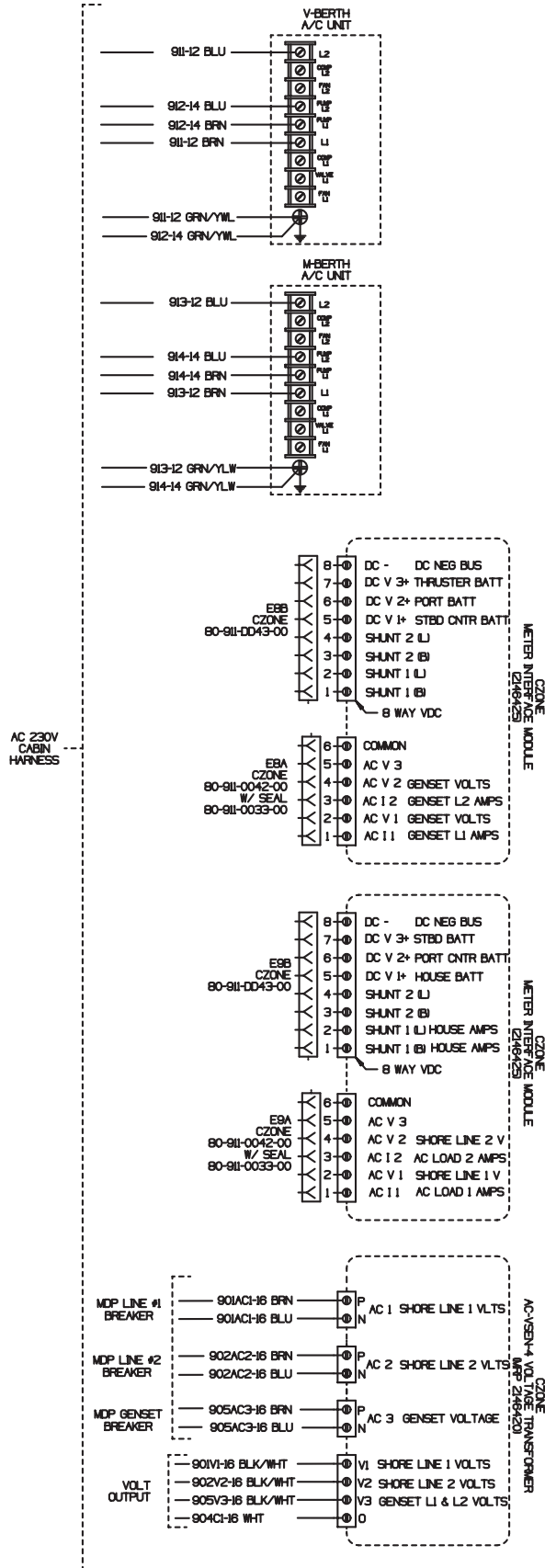

6029-07-401_8_I

AC Harness and Panel
(FIGURE 4.38.1)

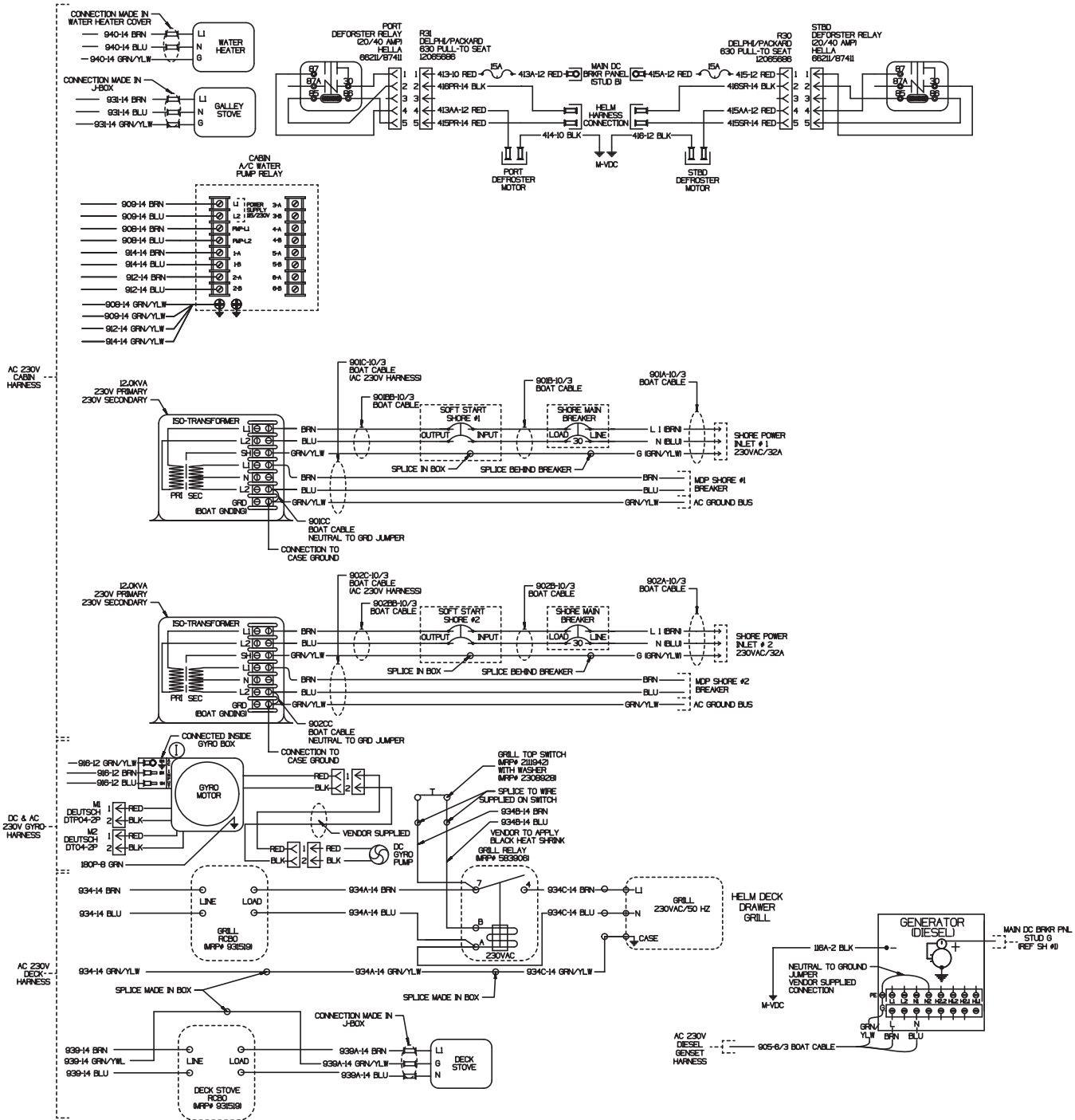

6029-07-401_8_I

AC Harness and Panel
(FIGURE 4.39.1)

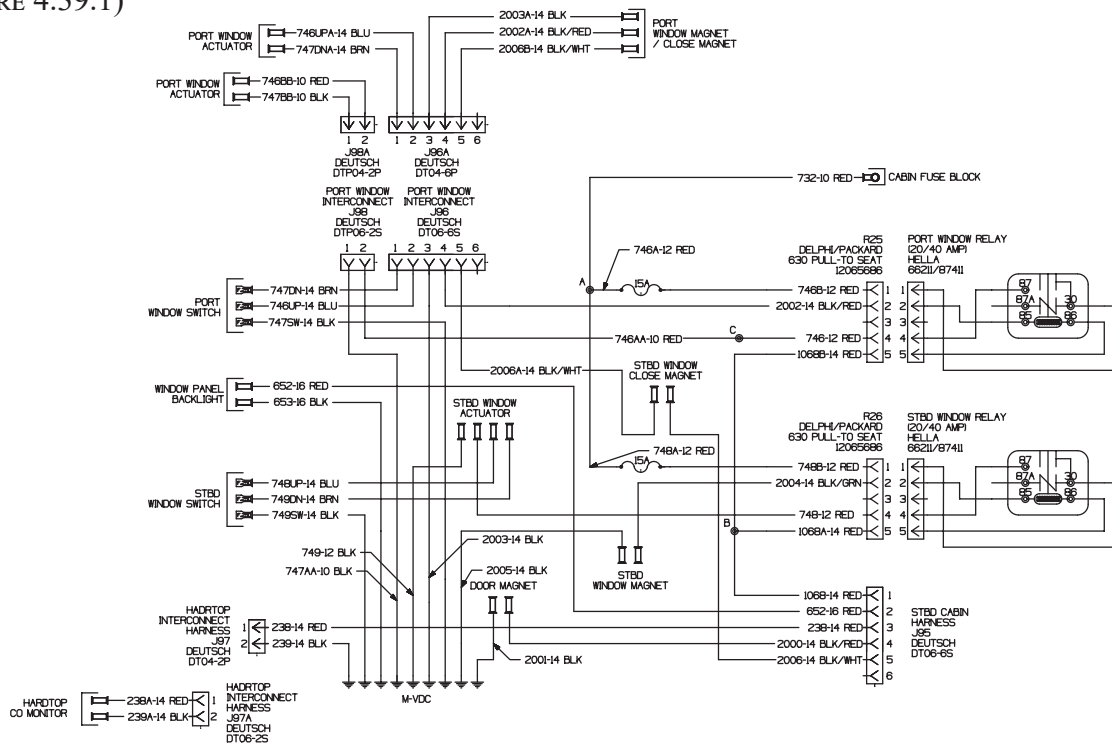

Mid Mechanical Access (Mid Bilge) Harness (FIGURE 4.41.1)

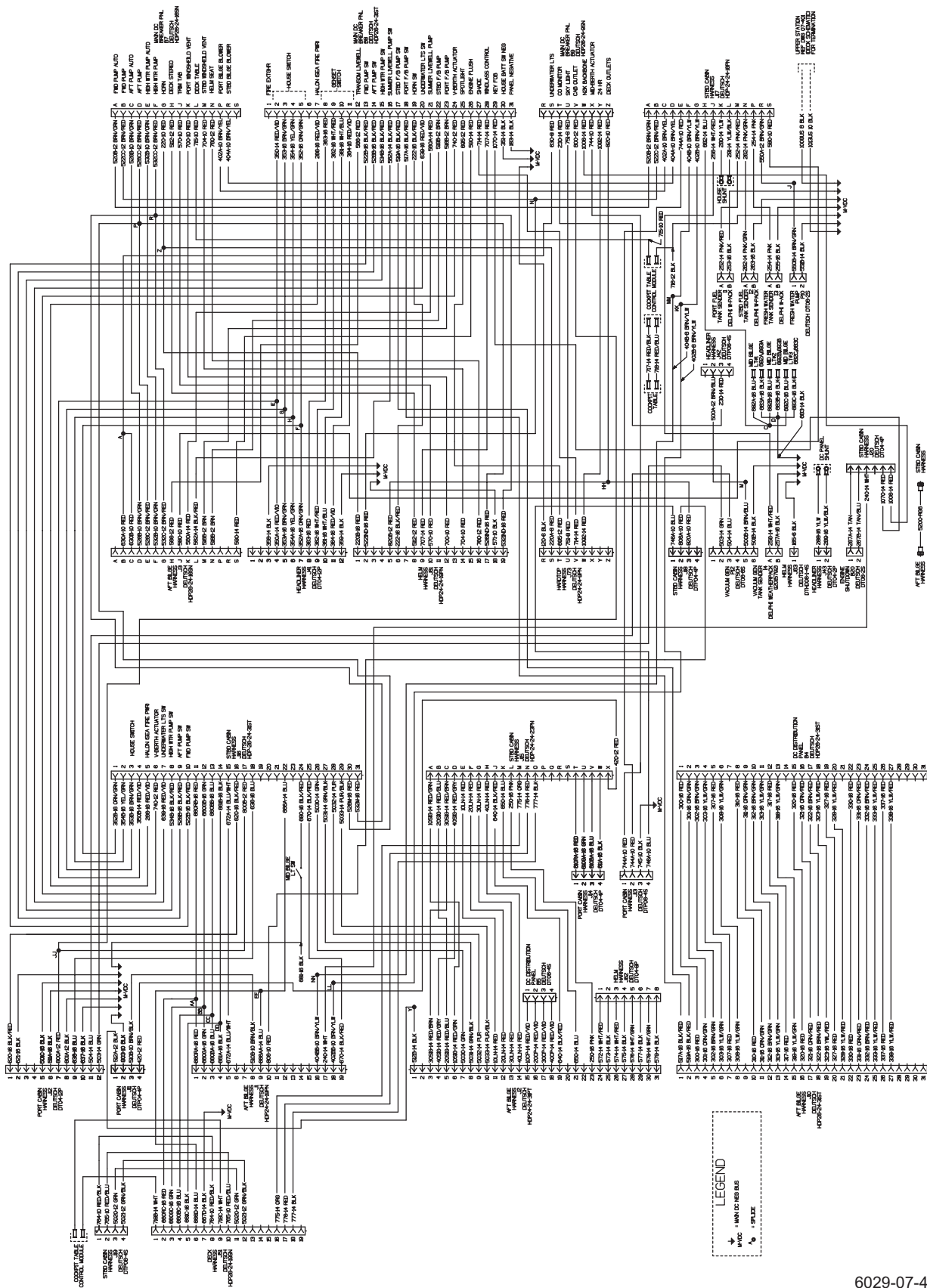

6029-07-401_10_I

Port Cabin Harness
(FIGURE 4.42.1)

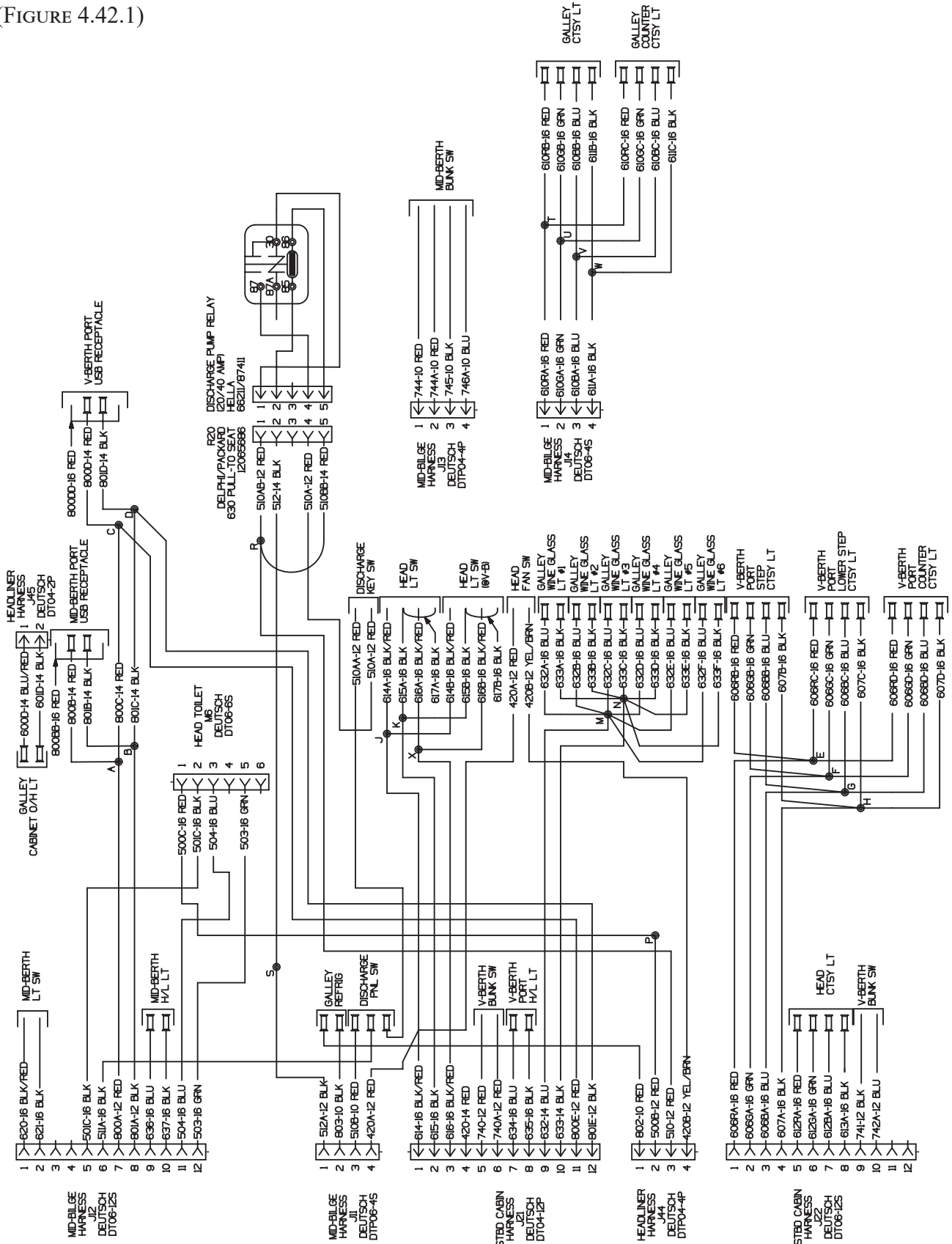

6029-07-401_11_I

Chapter 4 • Electrical

Starboard Cabin Harness (Page 1 of 2)
(FIGURE 4.43.1)

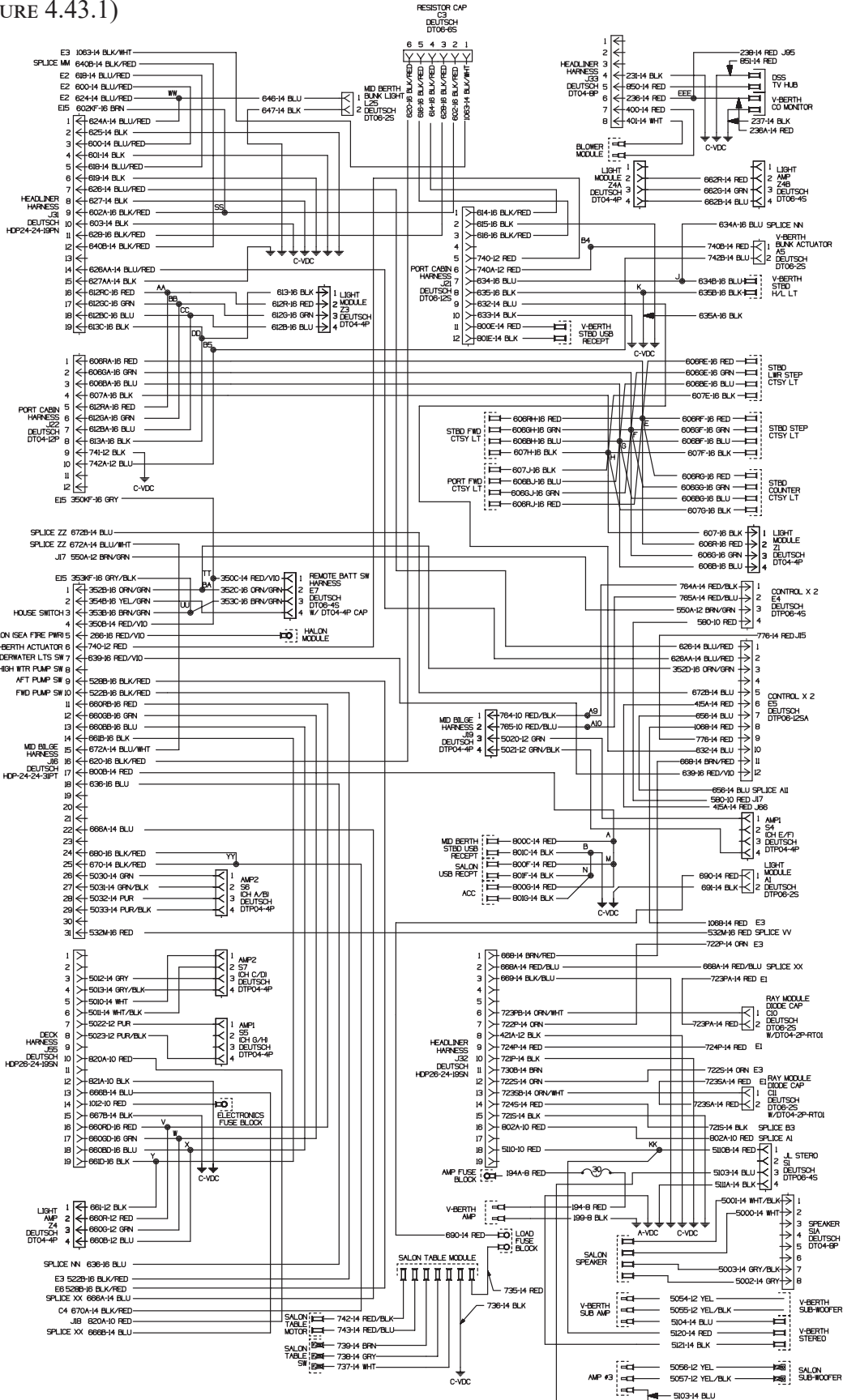

6029-07-401_12_I

Chapter 4 • Electrical

Starboard Cabin Harness (Page 2 of 2) (FIGURE 4.44.1)

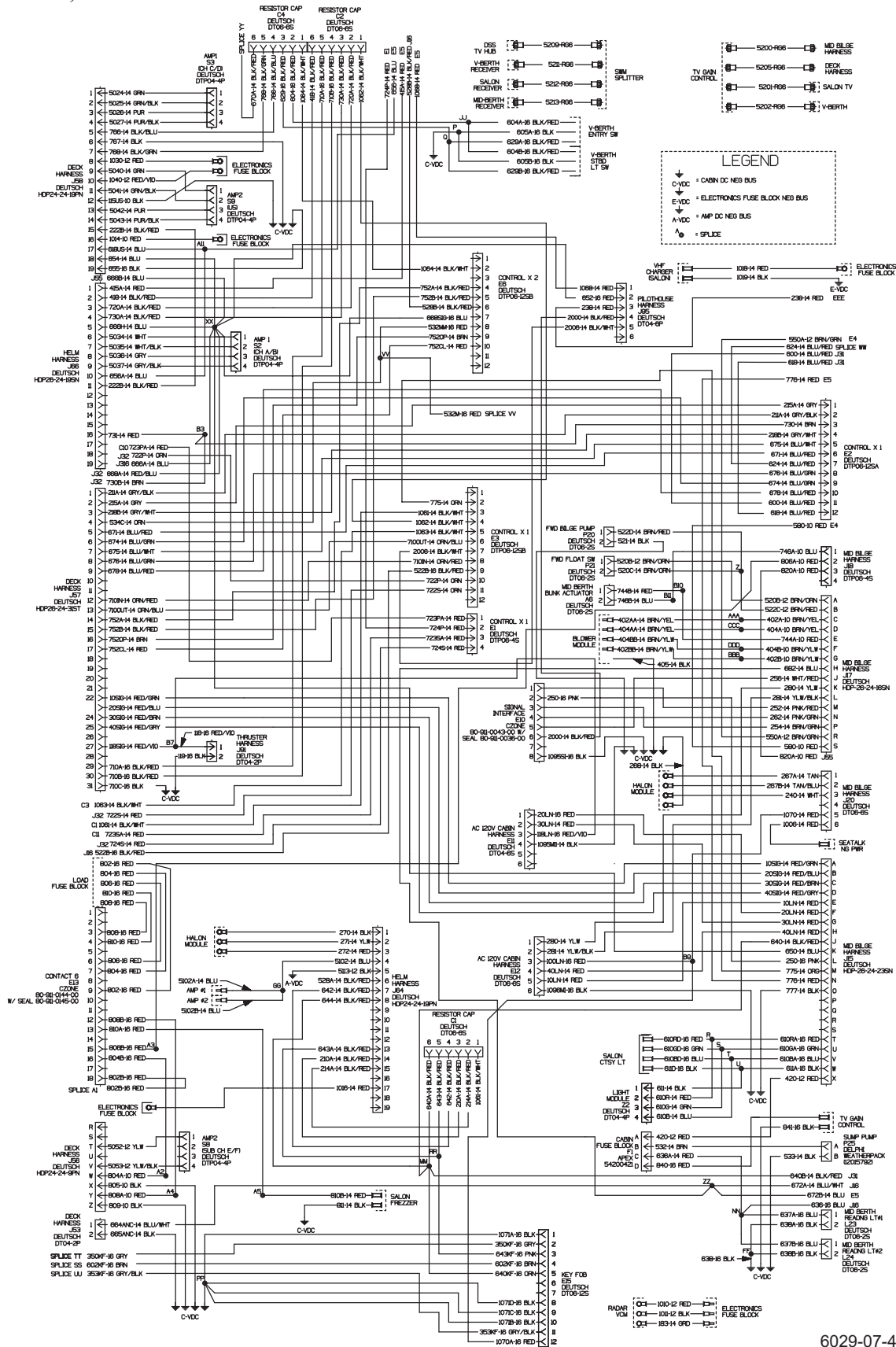

Chapter 4 • Electrical

Helm Harness (Page 1 of 2)
(FIGURE 4.45.1)

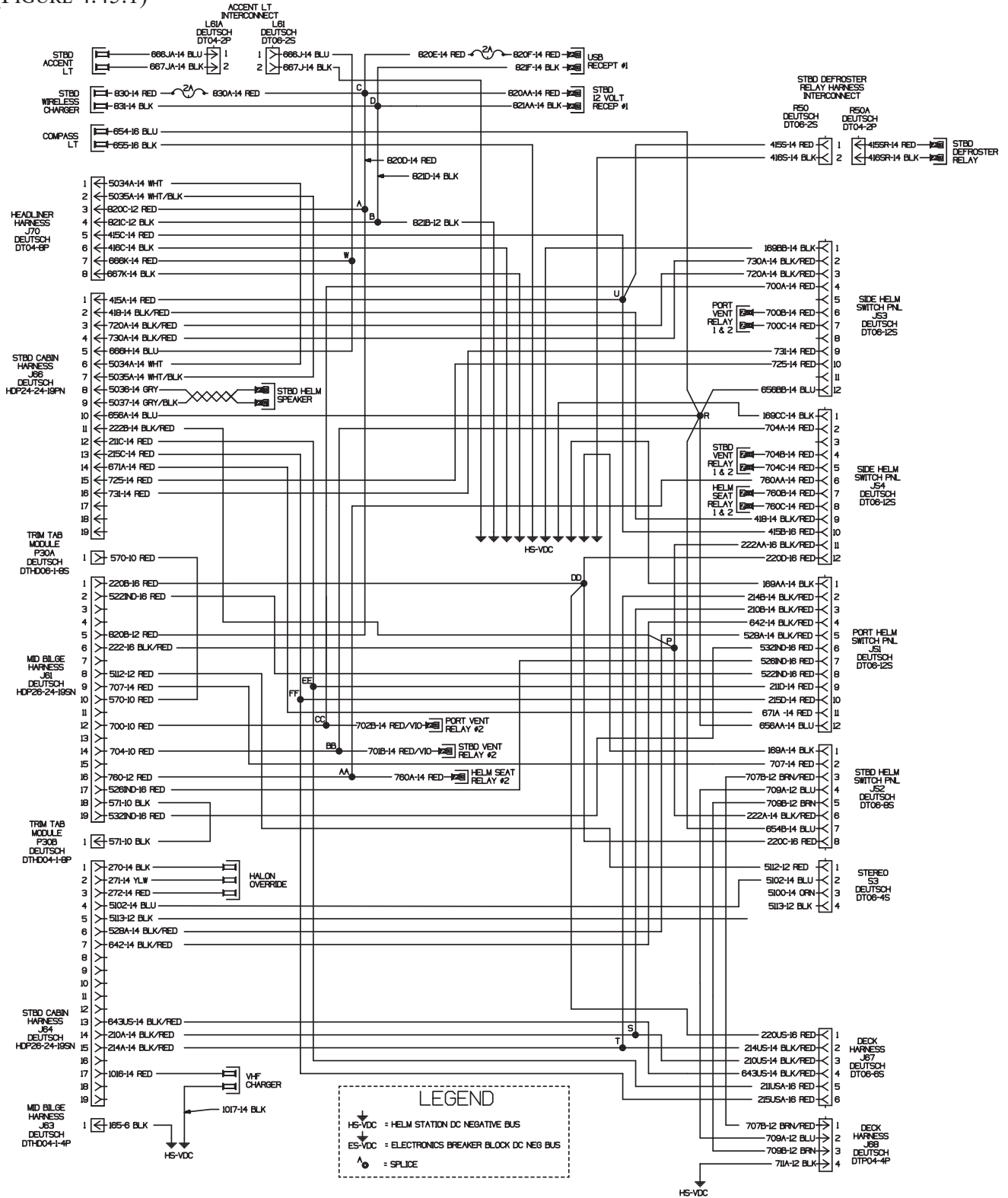

6029-07-401_14_I

Helm Harness (Page 2 of 2)
(FIGURE 4.46.1)

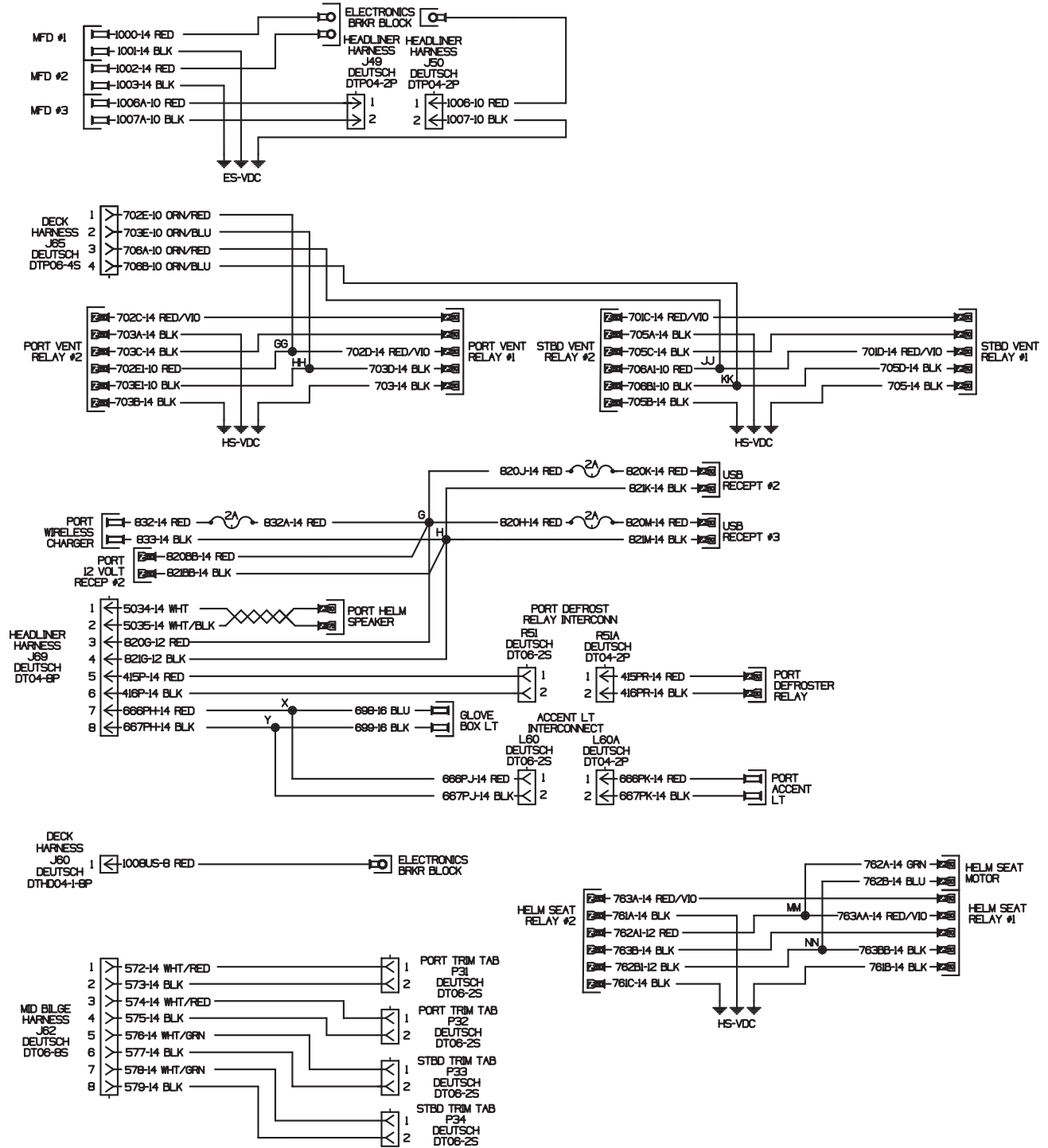

6029-07-401_14_I

Deck Harness (Page 2 of 2)
(FIGURE 4.49.1)

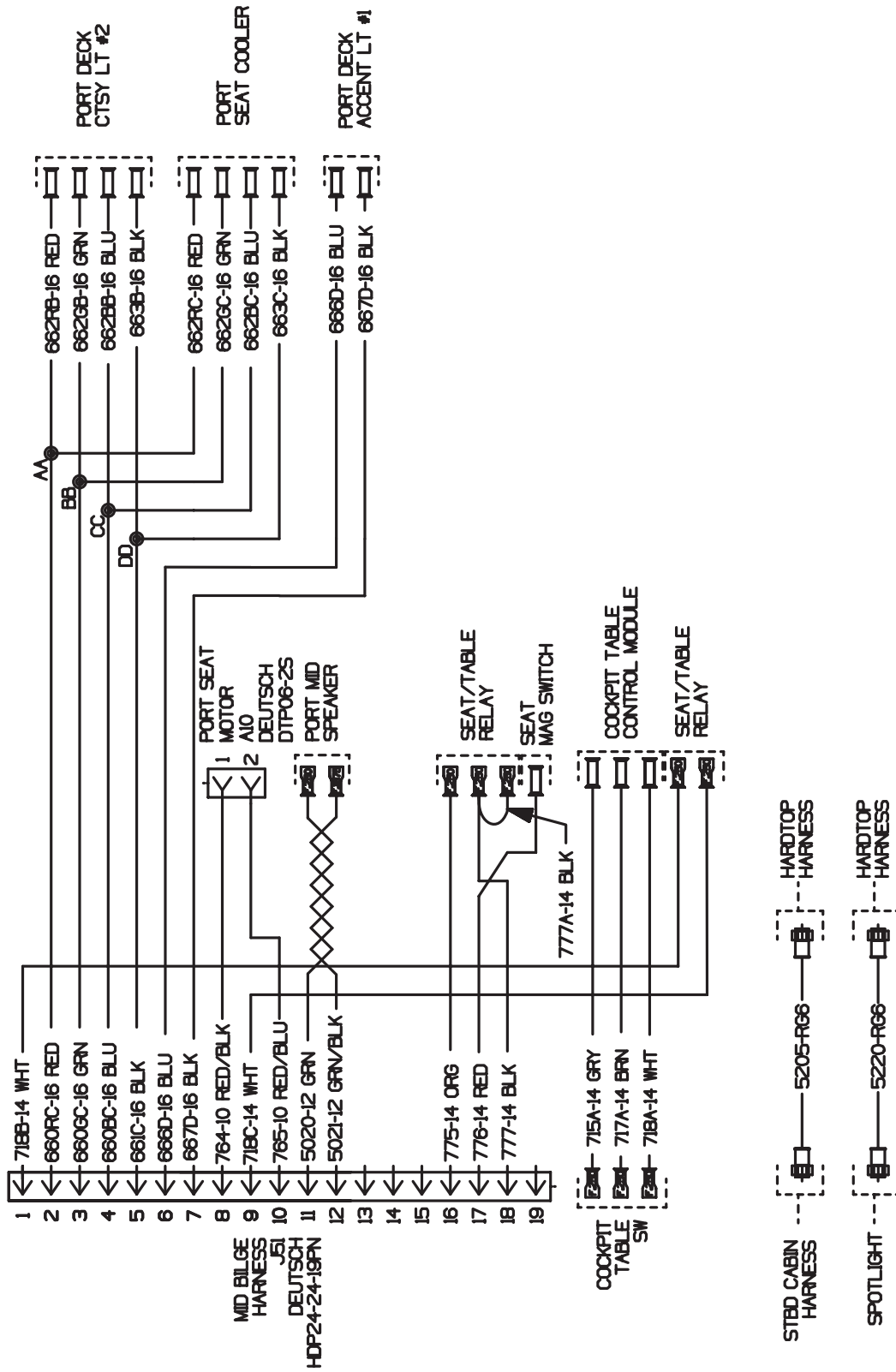

6029-07-401_16_I

Hardtop Harness
(FIGURE 4.50.1)

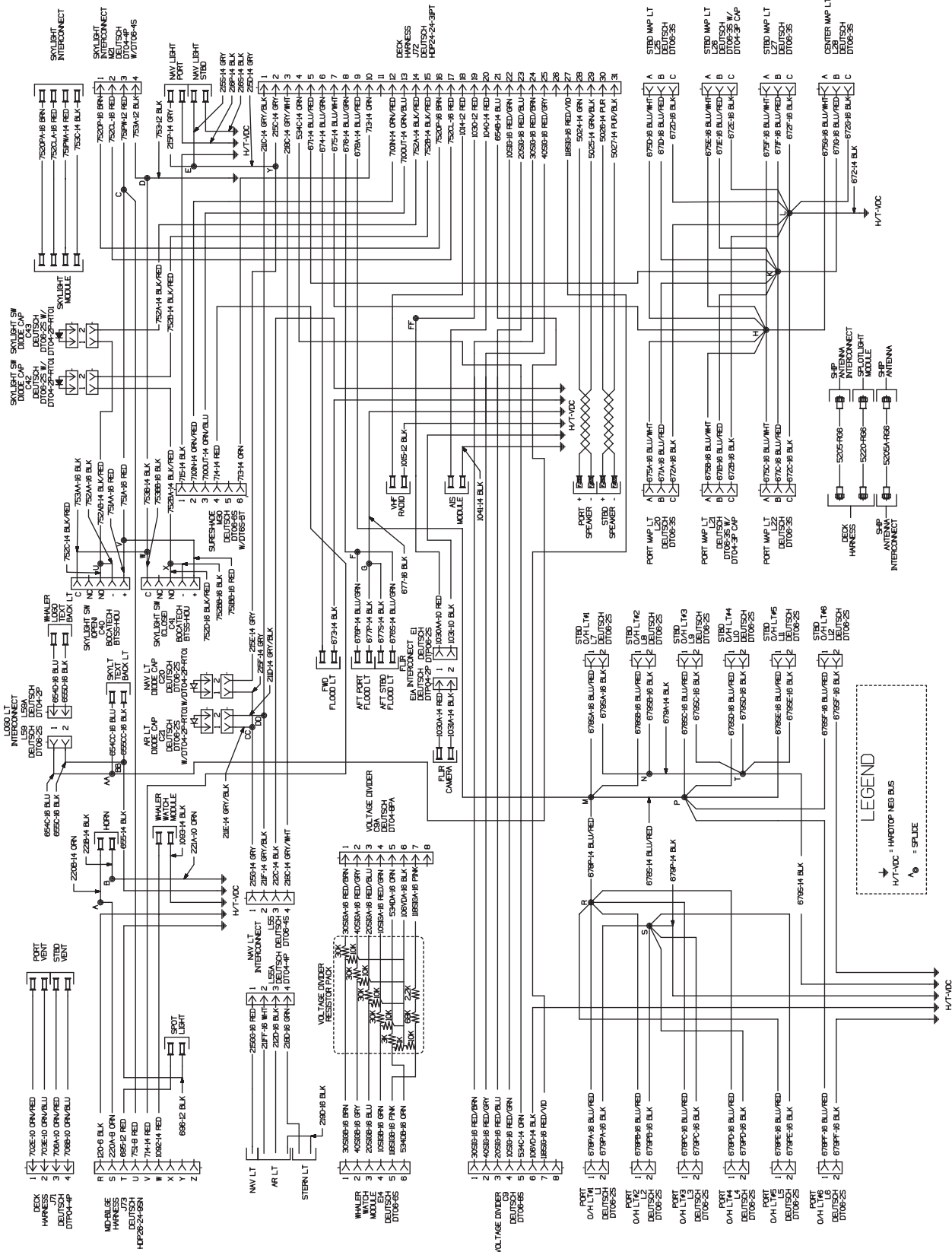

6029-07-401_17_I

Bow Thruster Switch Harness
(FIGURE 4.51.1)

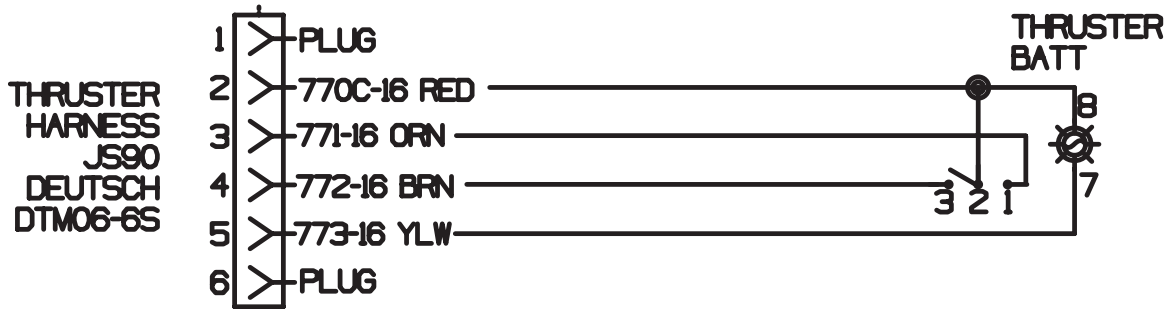

6029-07-401_18_I

Bow Thruster Harness
(FIGURE 4.51.2)

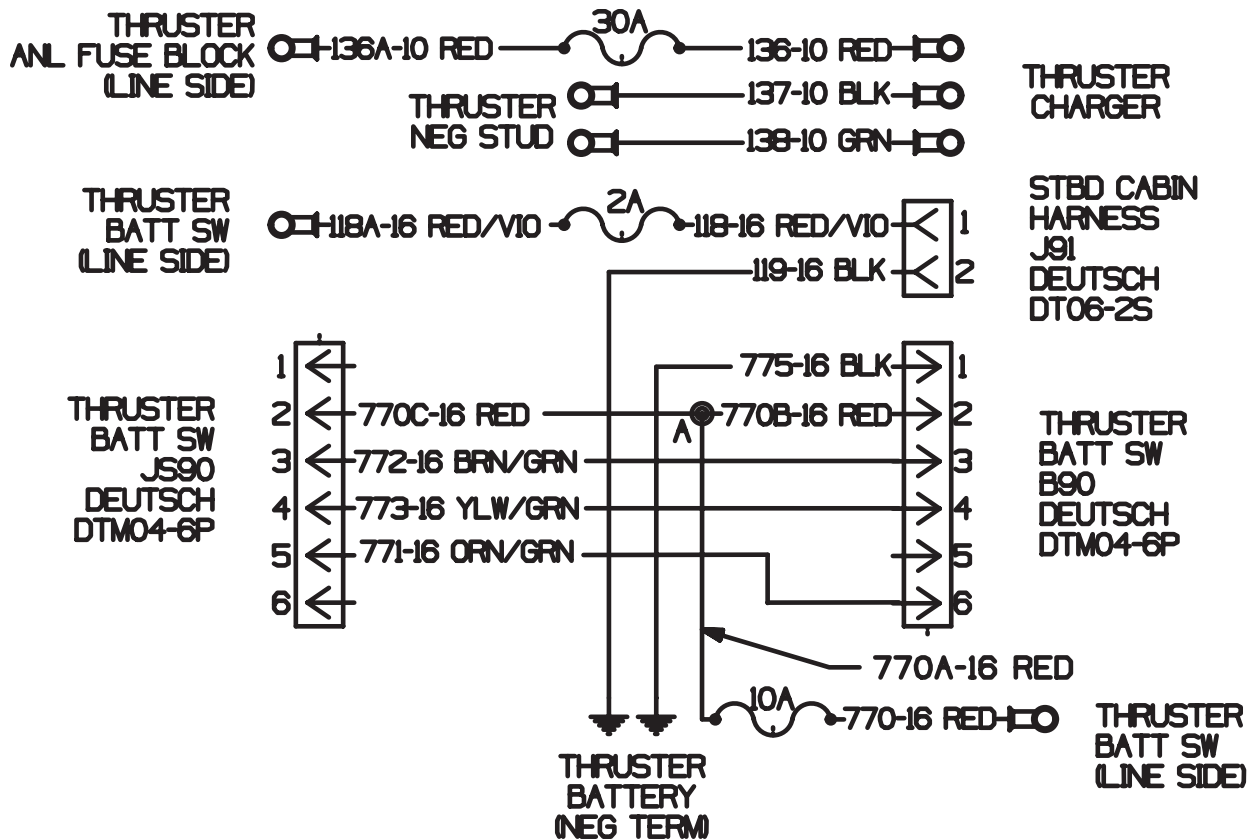

6029-07-401_18_I

Receptacle Wiring Harness
(FIGURE 4.52.1)

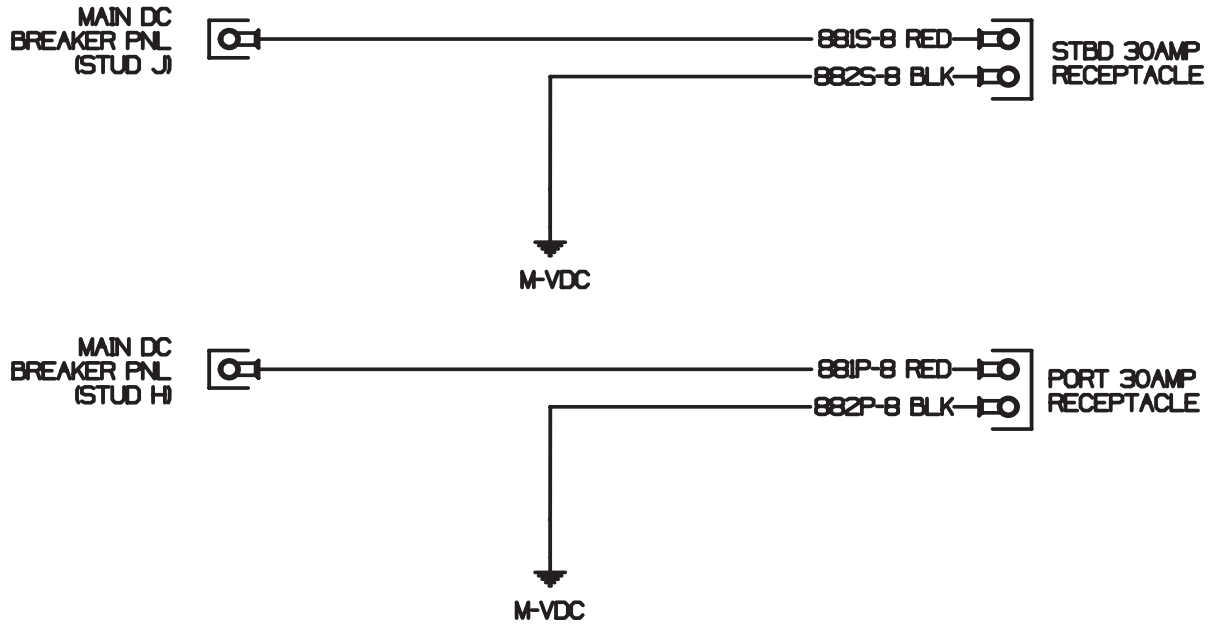

6029-07-401_18_I

Chapter 4 • Electrical

Diesel Generator 240VAC 60Hz Harness
(FIGURE 4.53.1)

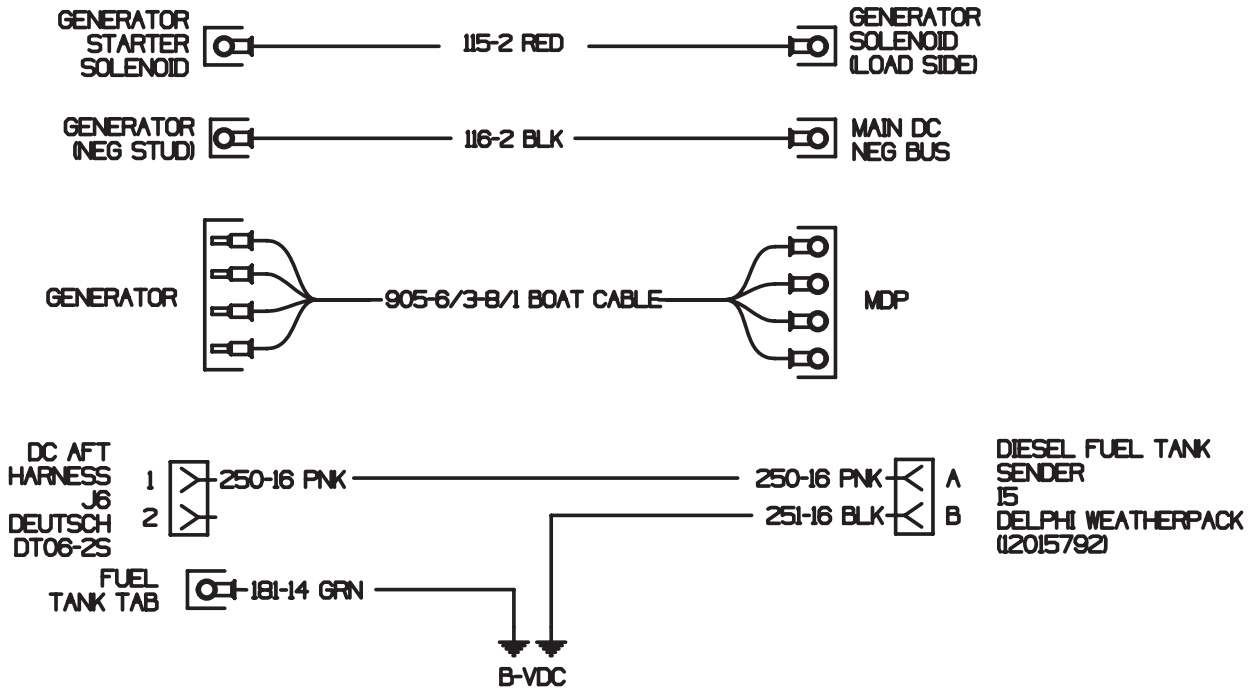

6029-07-401_18_I

Diesel Generator 230VAC 50Hz Harness
(FIGURE 4.53.2)

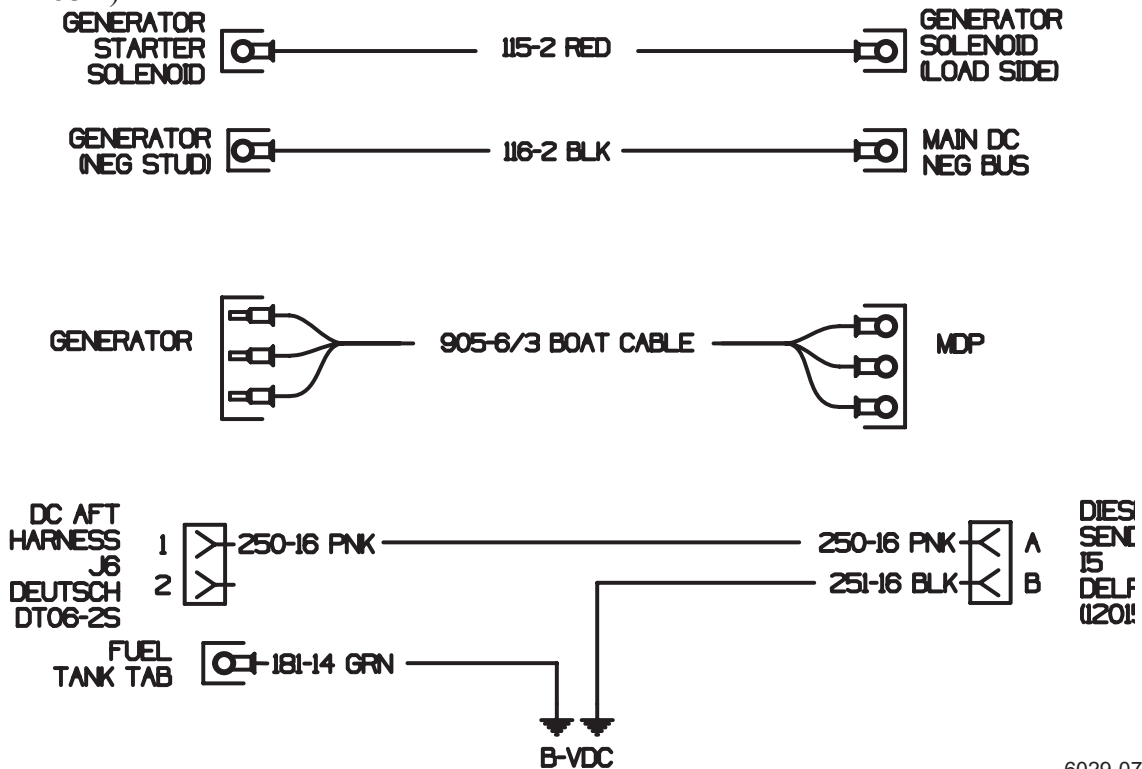

6029-07-401_18_I

Gyroscopic Stabilizer 240VAC 60Hz Harness
(FIGURE 4.54.1)

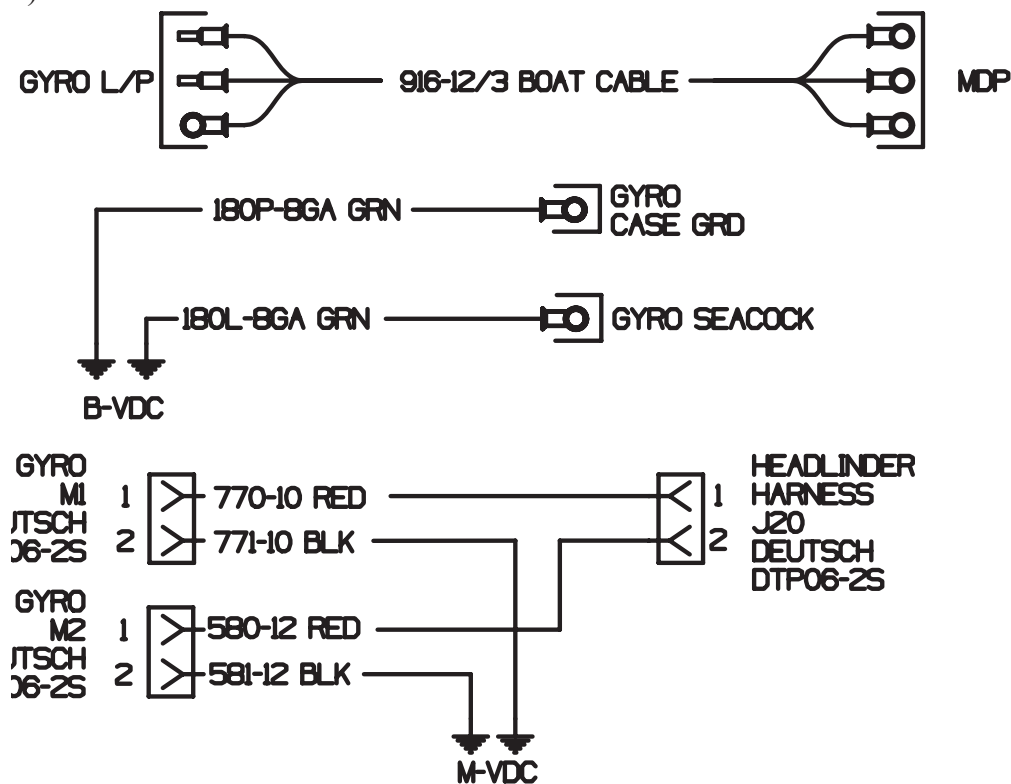

6029-07-401_18_I

Gyroscopic Stabilizer 230VAC 50Hz Harness
(FIGURE 4.54.2)

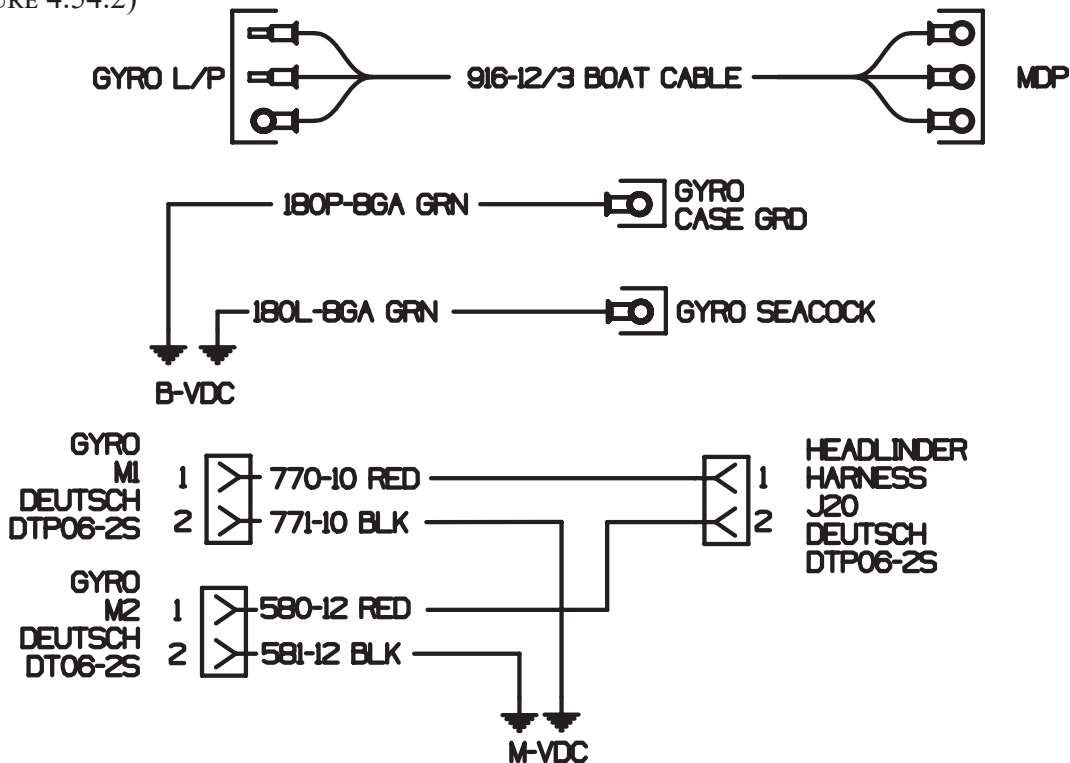

6029-07-401_18_I

Chapter 4 • Electrical

Cabin 230VAC 50Hz Harness (Page 1 of 2)
(FIGURE 4.56.1)

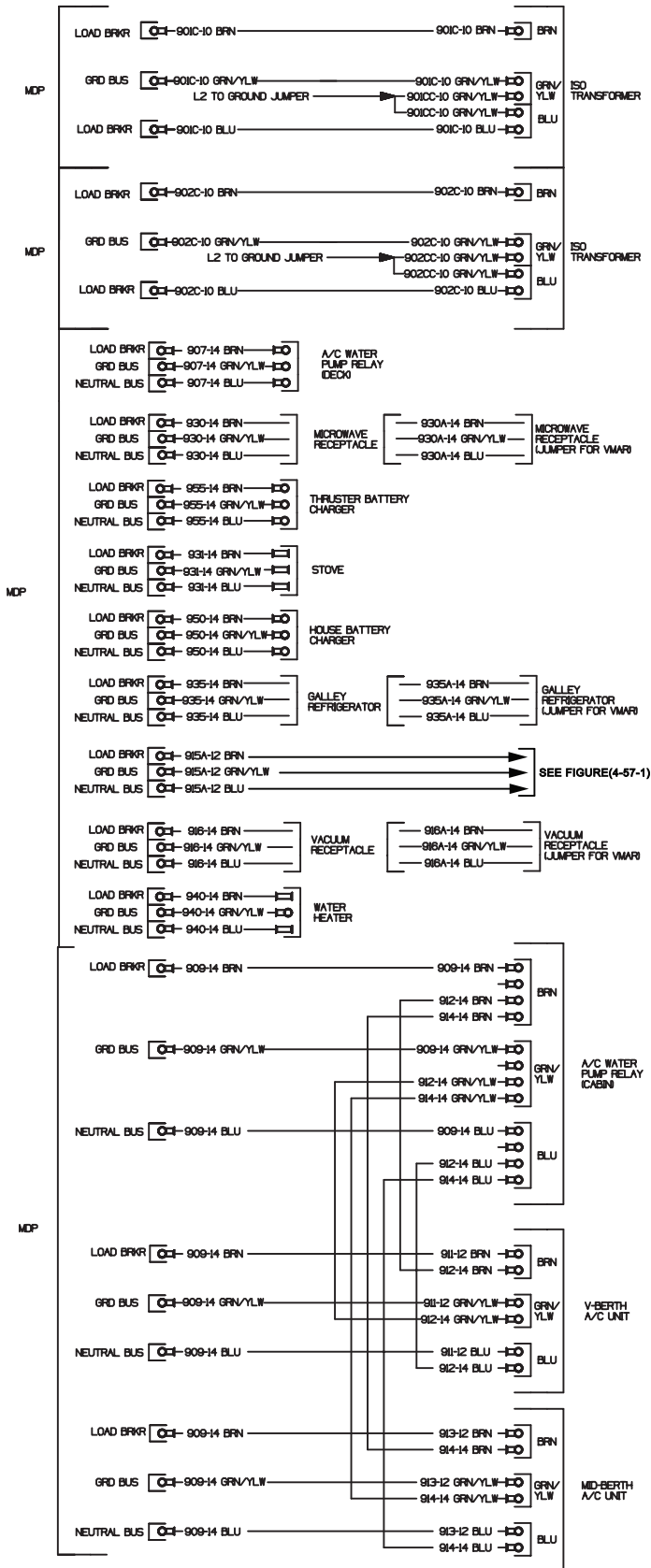

6029-07-401_20_I

Chapter 4 • Electrical

Cabin 230VAC 50Hz Harness (Page 2 of 2)
(FIGURE 4.57.1)

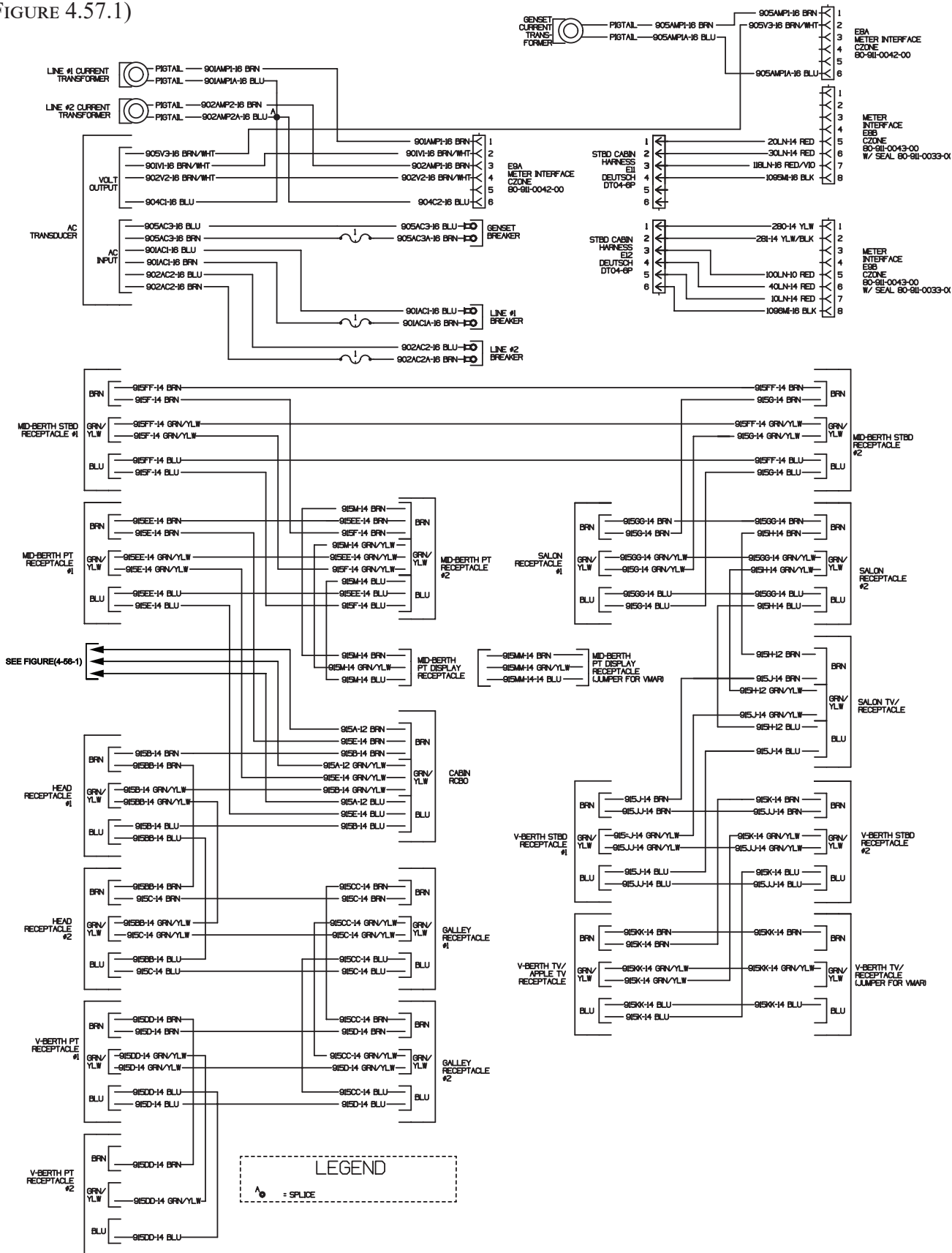

LEGEND
 = SPLICE

6029-07-401_20_I

Chapter 4 • Electrical

Deck 230VAC 50Hz Harness (Page 1 of 3)
(FIGURE 4.59.1)

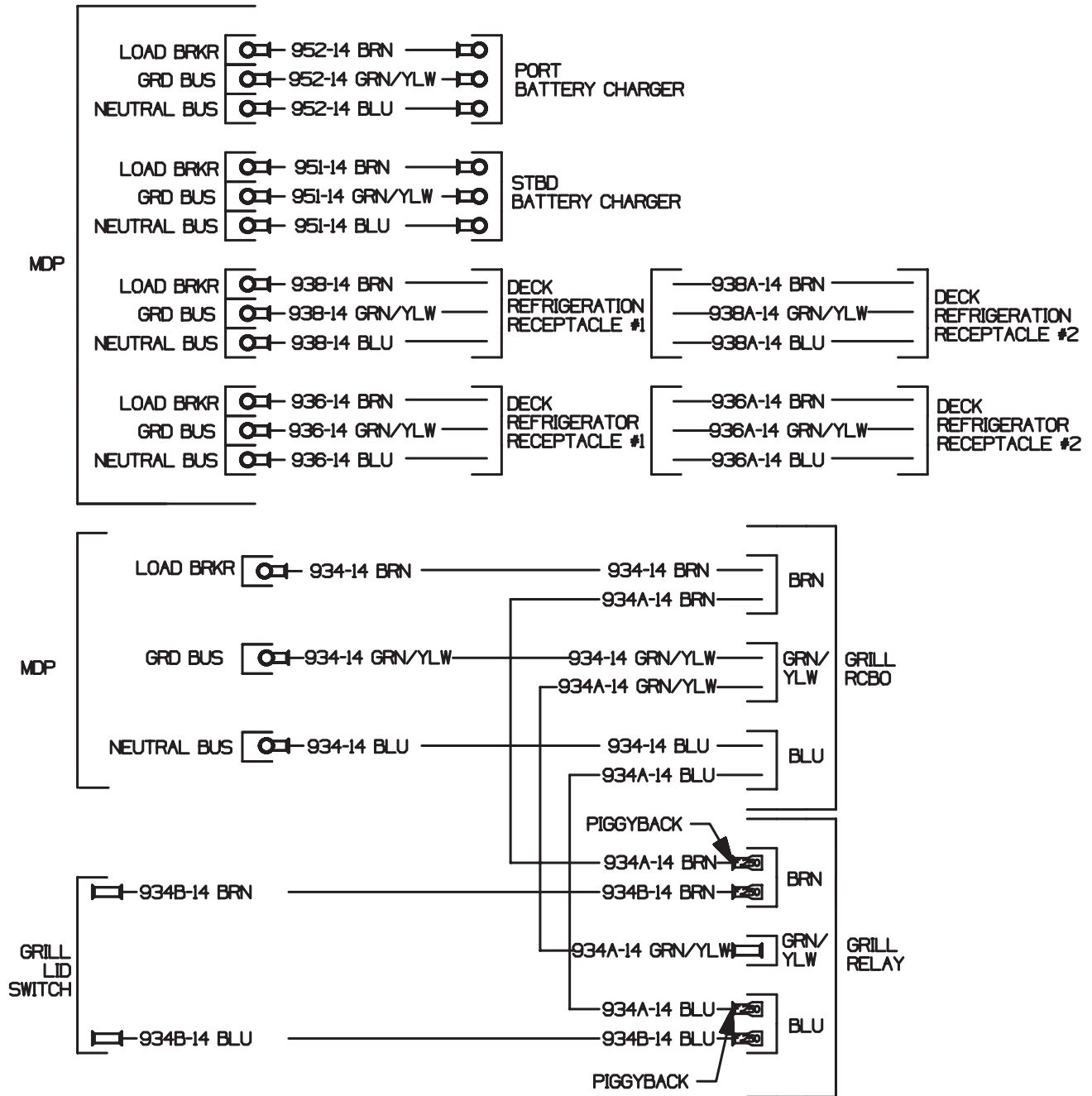

6029-07-401_22_I

Deck 230VAC 50Hz Harness (Page 2 of 3)
(FIGURE 4.60.1)

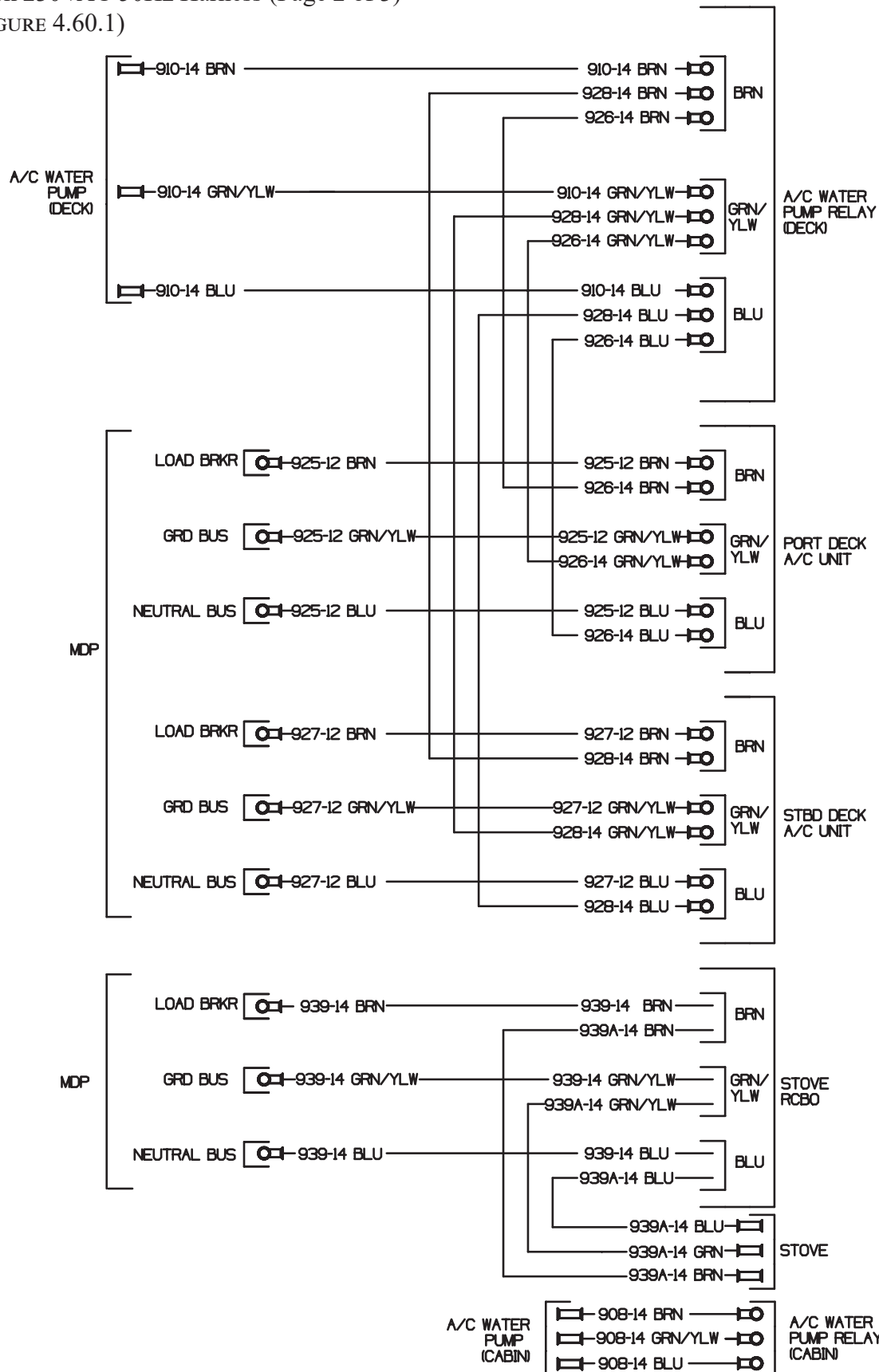

6029-07-401_22_I

Chapter 4 • Electrical

Deck 230VAC 50Hz Harness (Page 3 of 3)
(FIGURE 4.61.1)

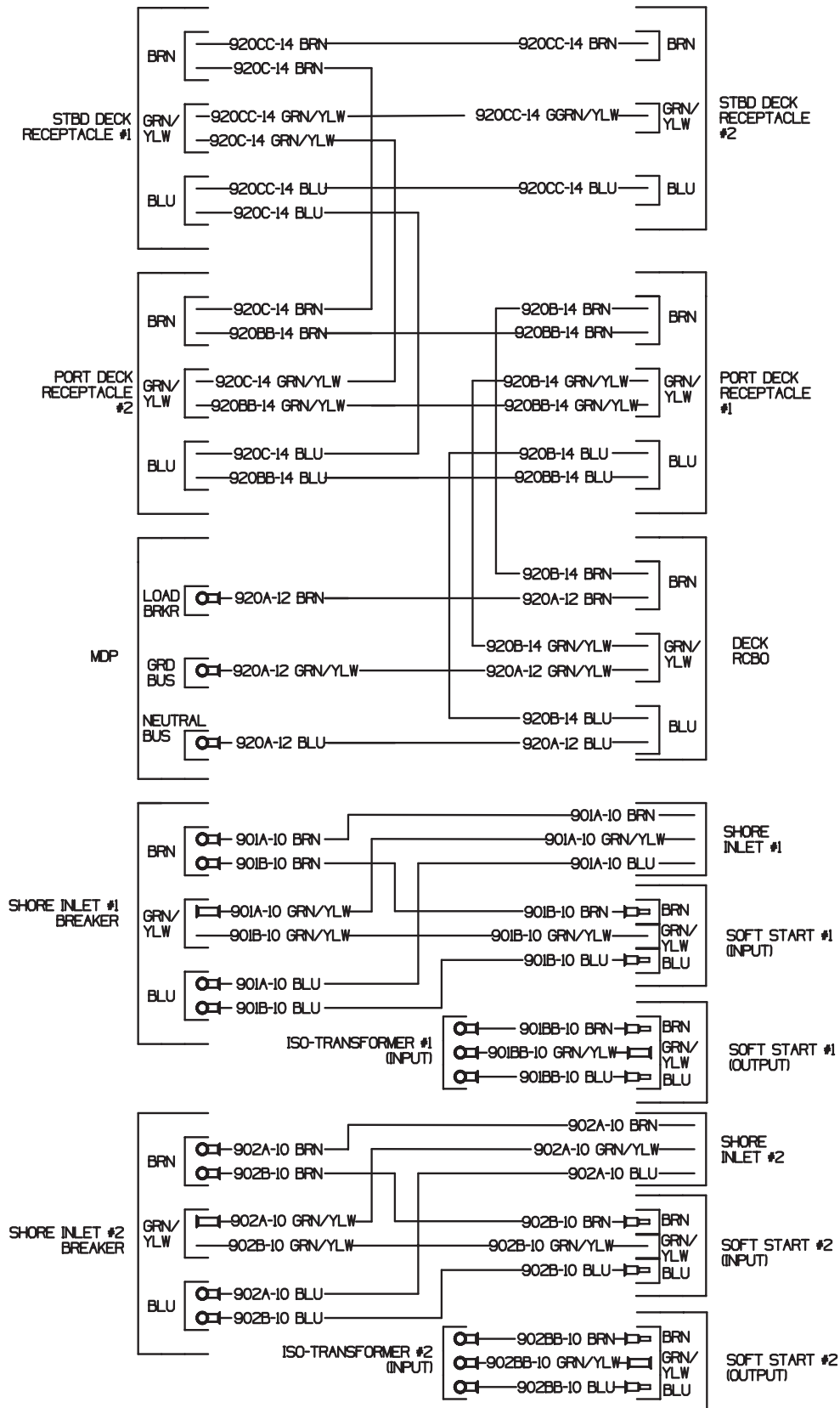

6029-07-401_22_I

Summer Kitchen AC and DC Domestic harness
(FIGURE 4.62.1)

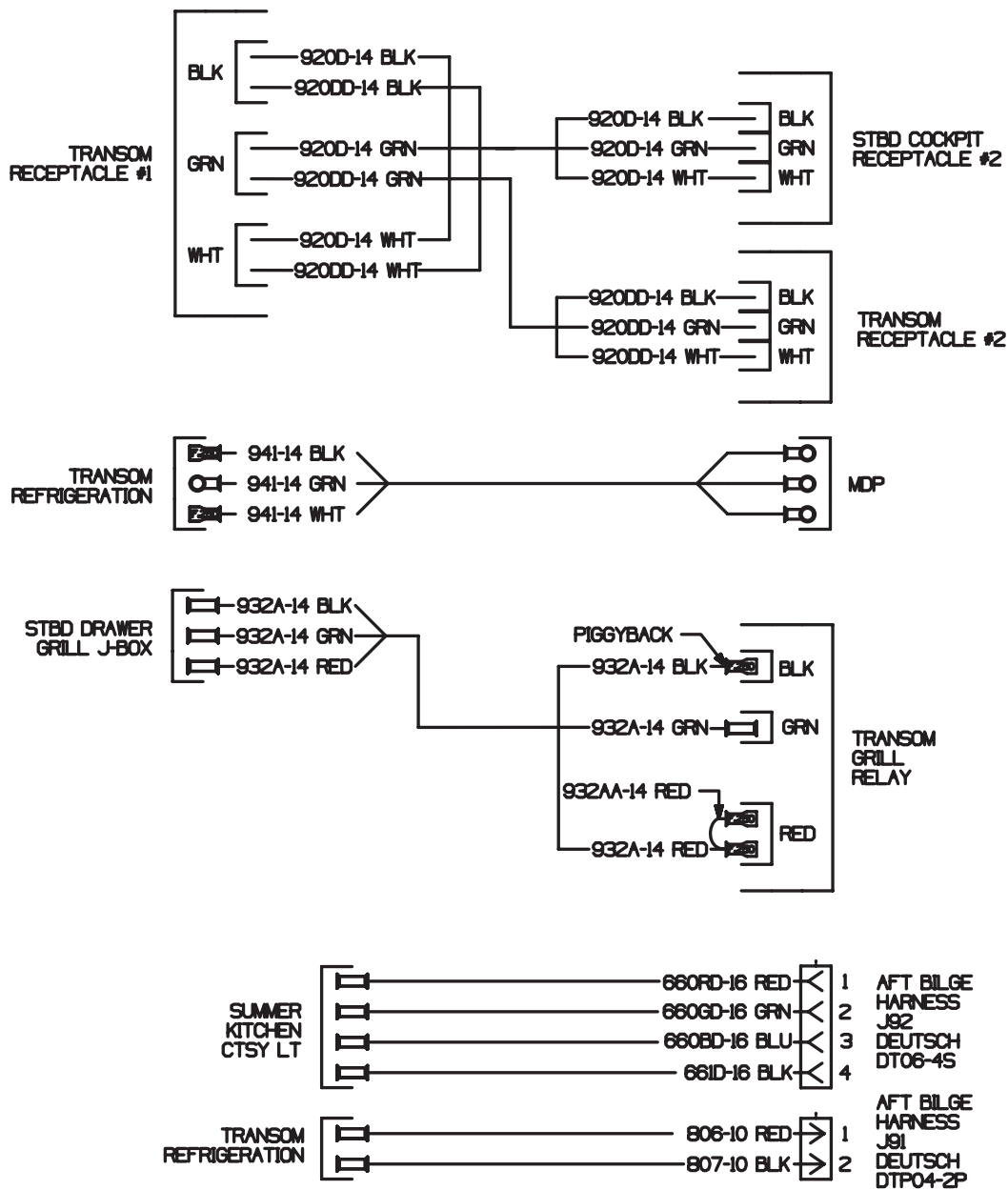

6029-07-401_23_I

Chapter 4 • Electrical

Summer Kitchen AC and DC International Harness
(FIGURE 4.63.1)

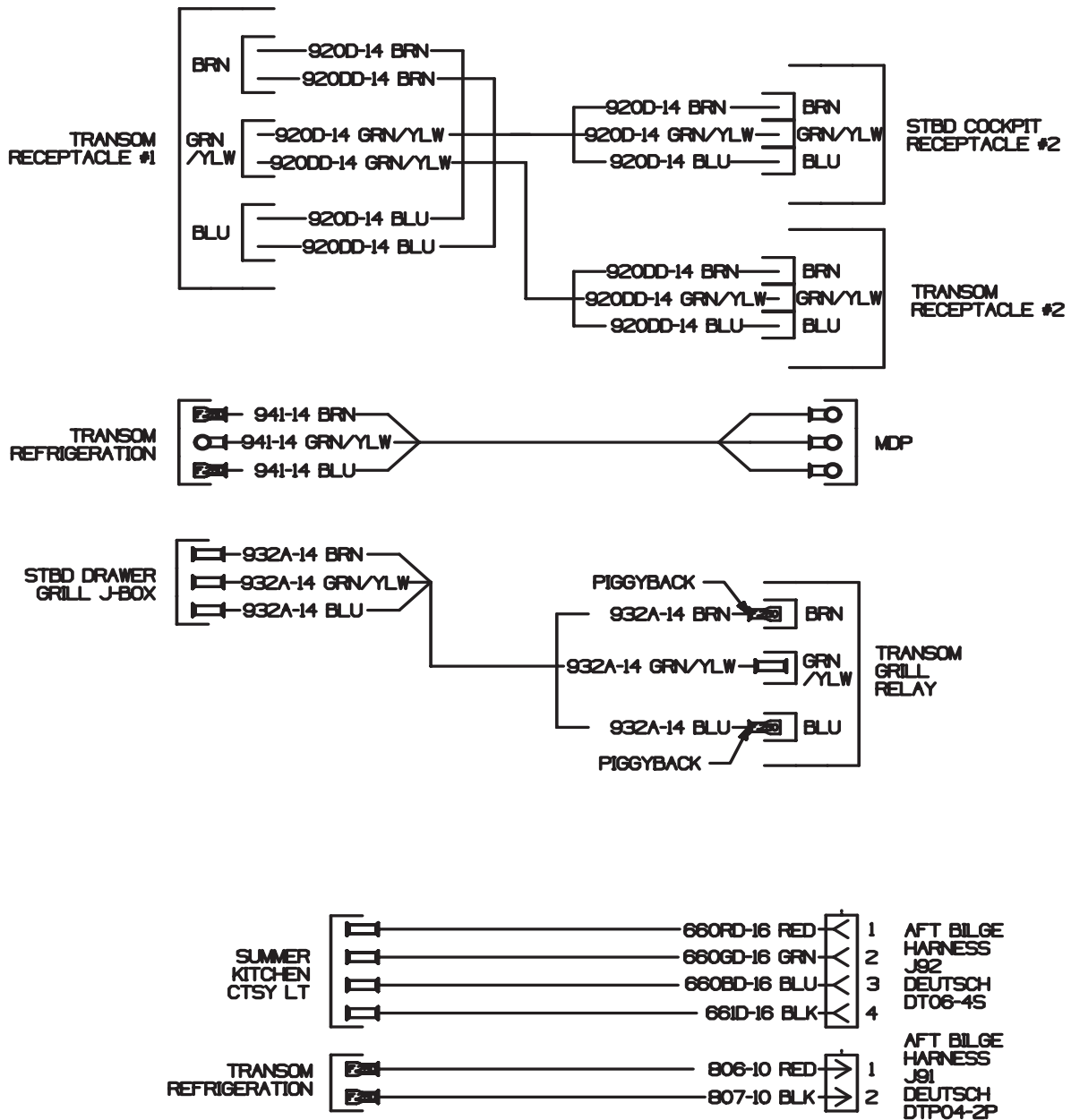

6029-07-401_23_I

Livewell AC and DC Domestic Harness
(FIGURE 4.64.1)

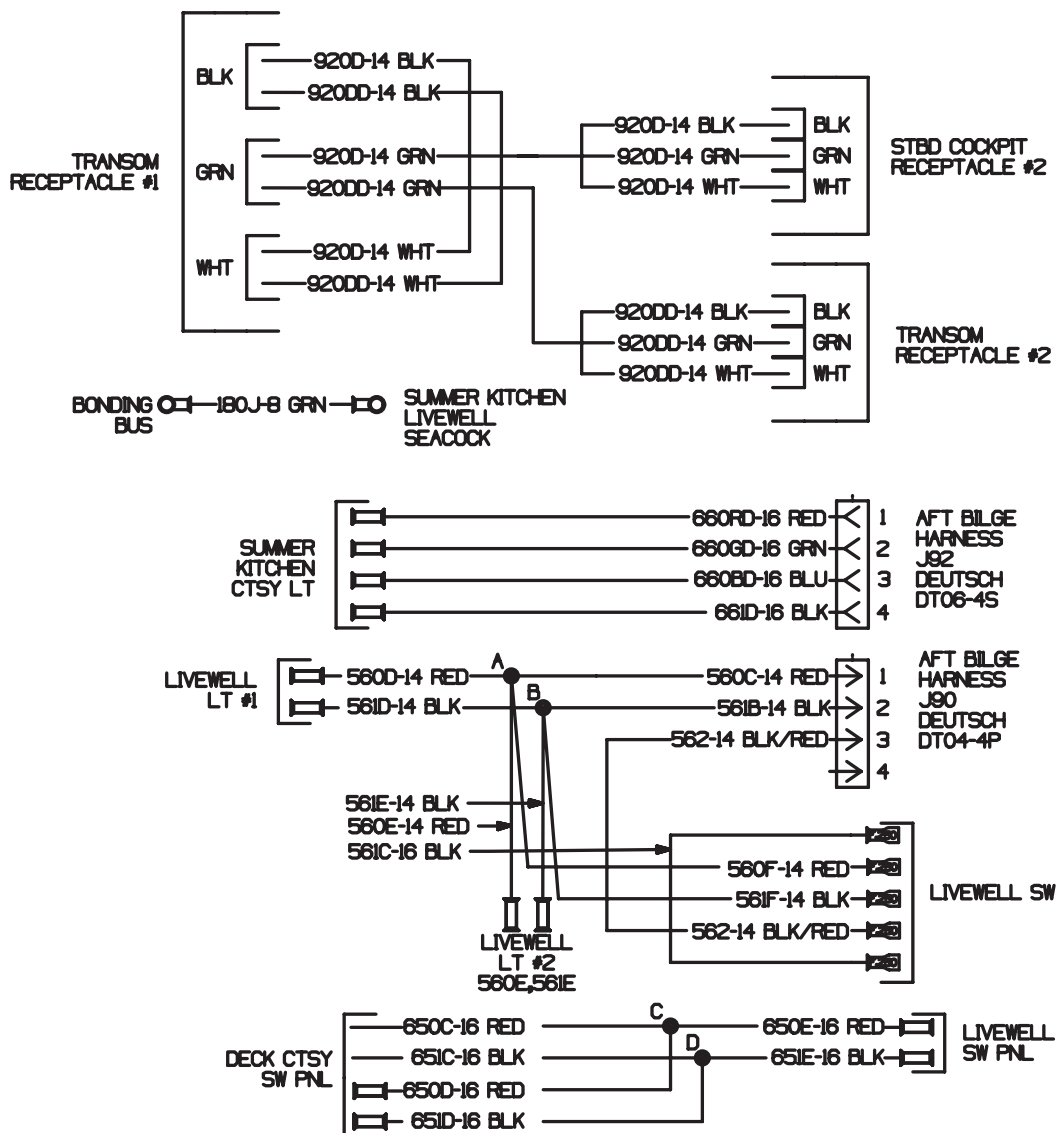

6029-07-401_23_I

Chapter 4 • Electrical

Livewell AC and DC International Harness
(FIGURE 4.65.1)

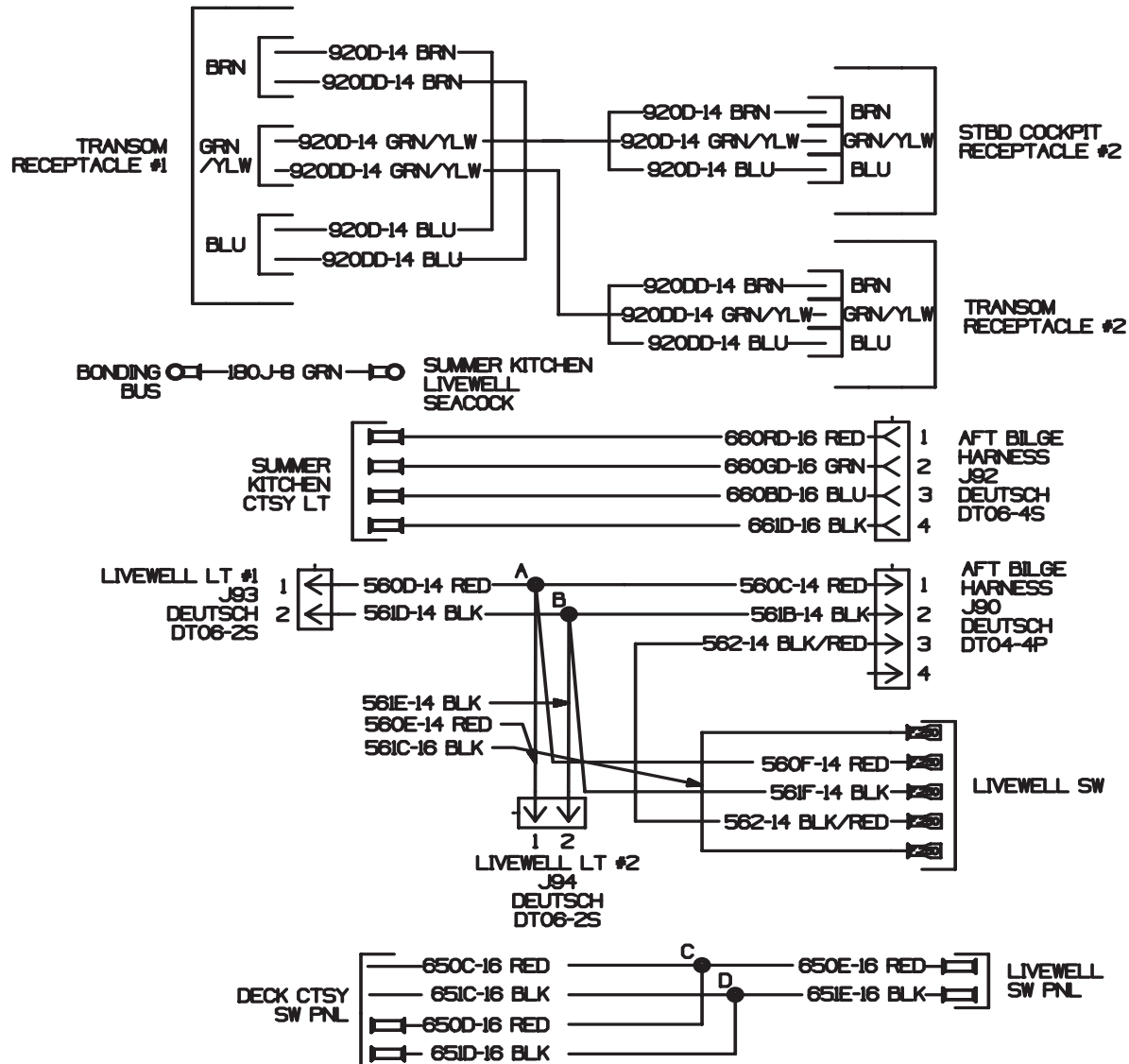

6029-07-401_23_I

Refrigerator and Chiller DC and 120VAC 60Hz Wiring Schematic
(FIGURE 4.66.1)

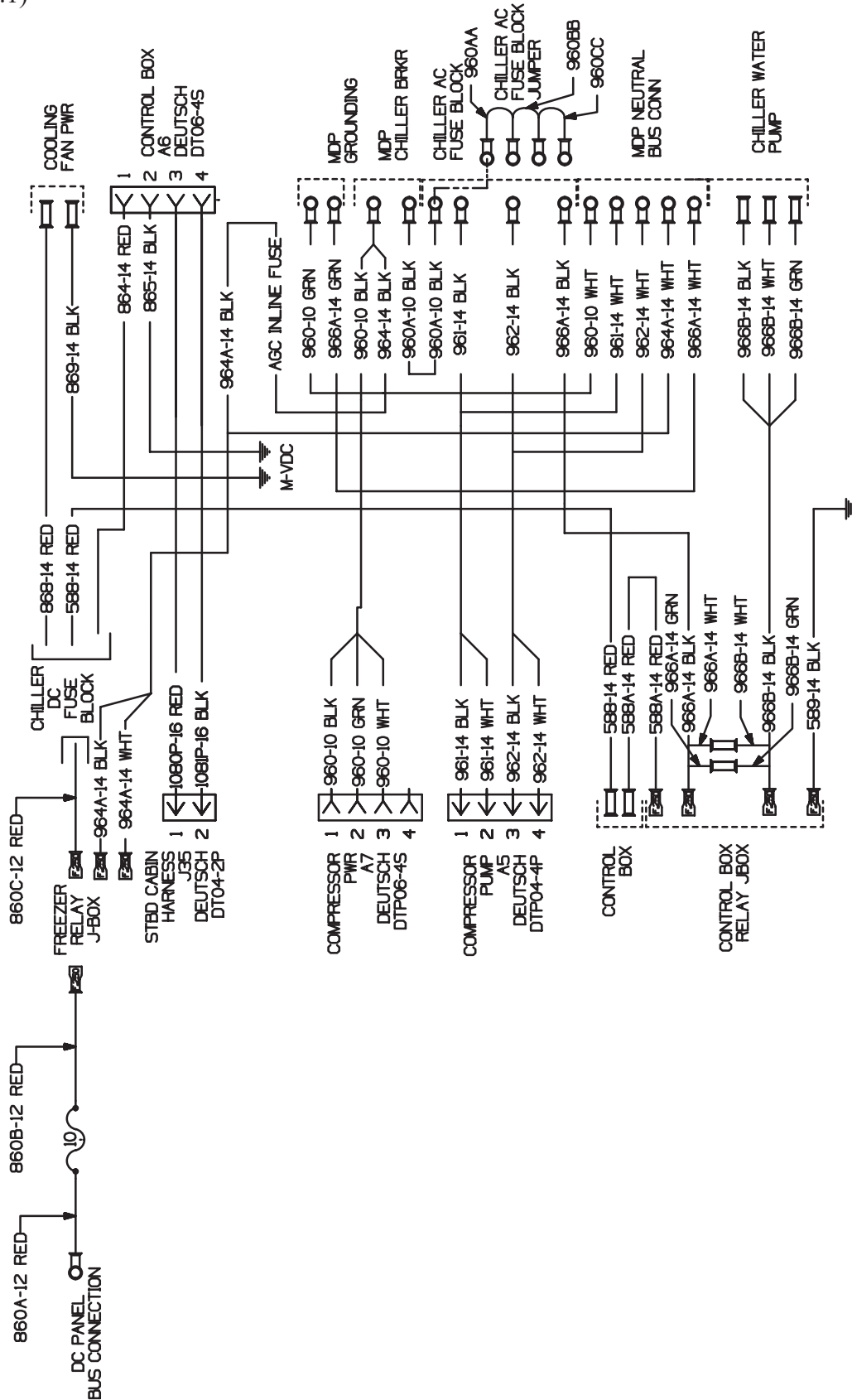

6029-07-401_24_I

Refrigerator and Chiller DC and 230VAC 50Hz Wiring Schematic
(FIGURE 4.67.1)

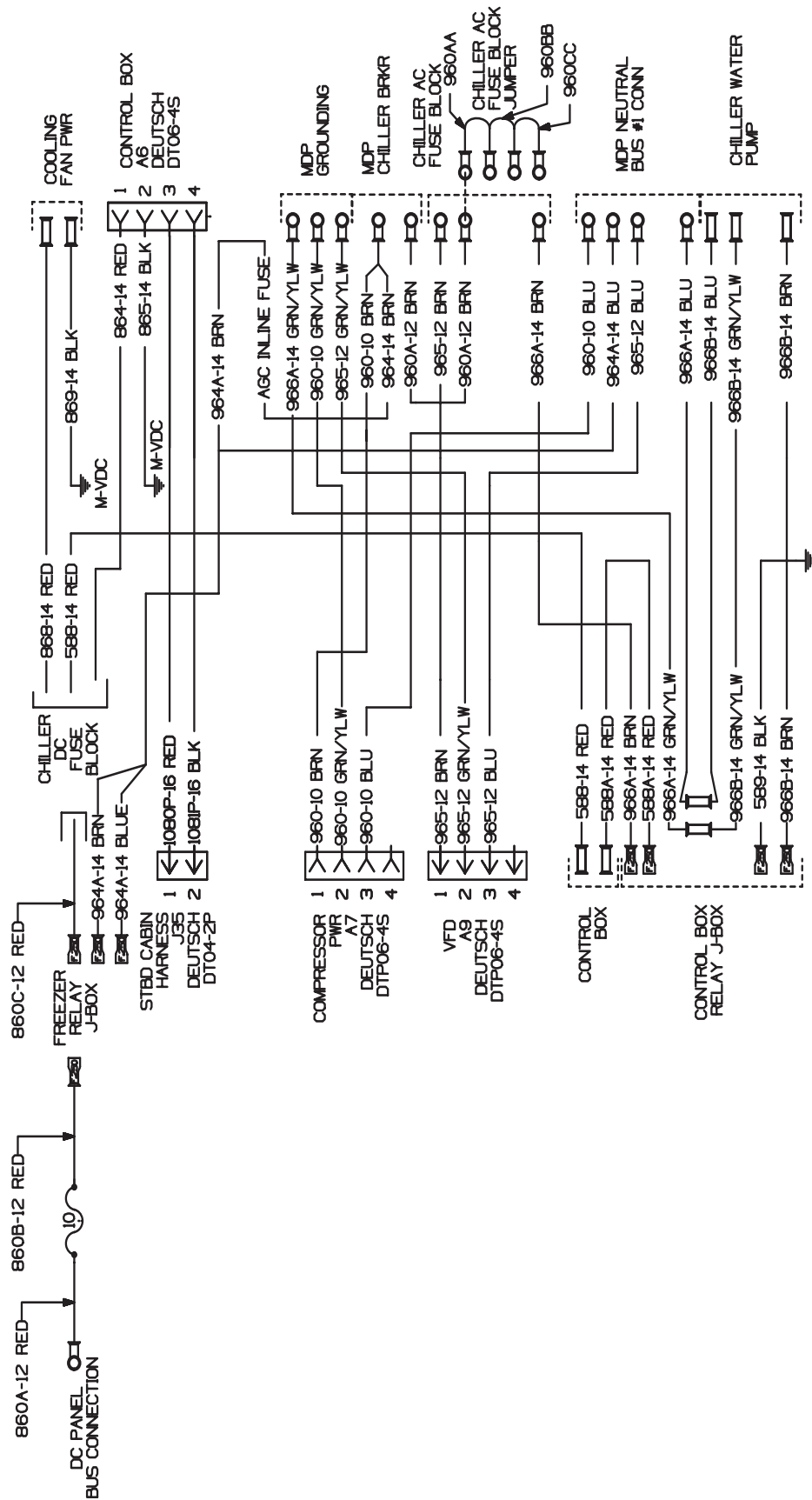

6029-07-401_24_I

Cabin Freezer DC and 120VAC 60Hz Harness
(FIGURE 4.68.1)



6029-07-401_24_I

Cabin Freezer DC and 230VAC 50Hz Harness
(FIGURE 4.68.2)



6029-07-401_24_I

Diesel Heater Harness
(FIGURE 4.68.3)

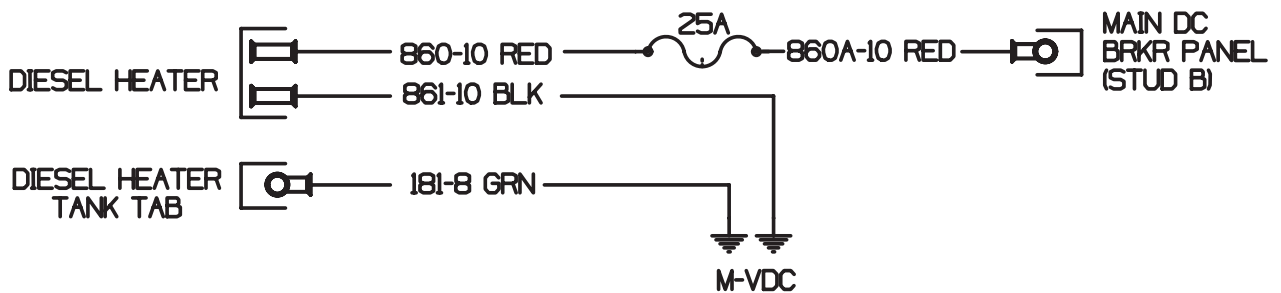

6029-07-401_25_I

Main Breaker Panel 12VDC (FIGURE 4.72.1)

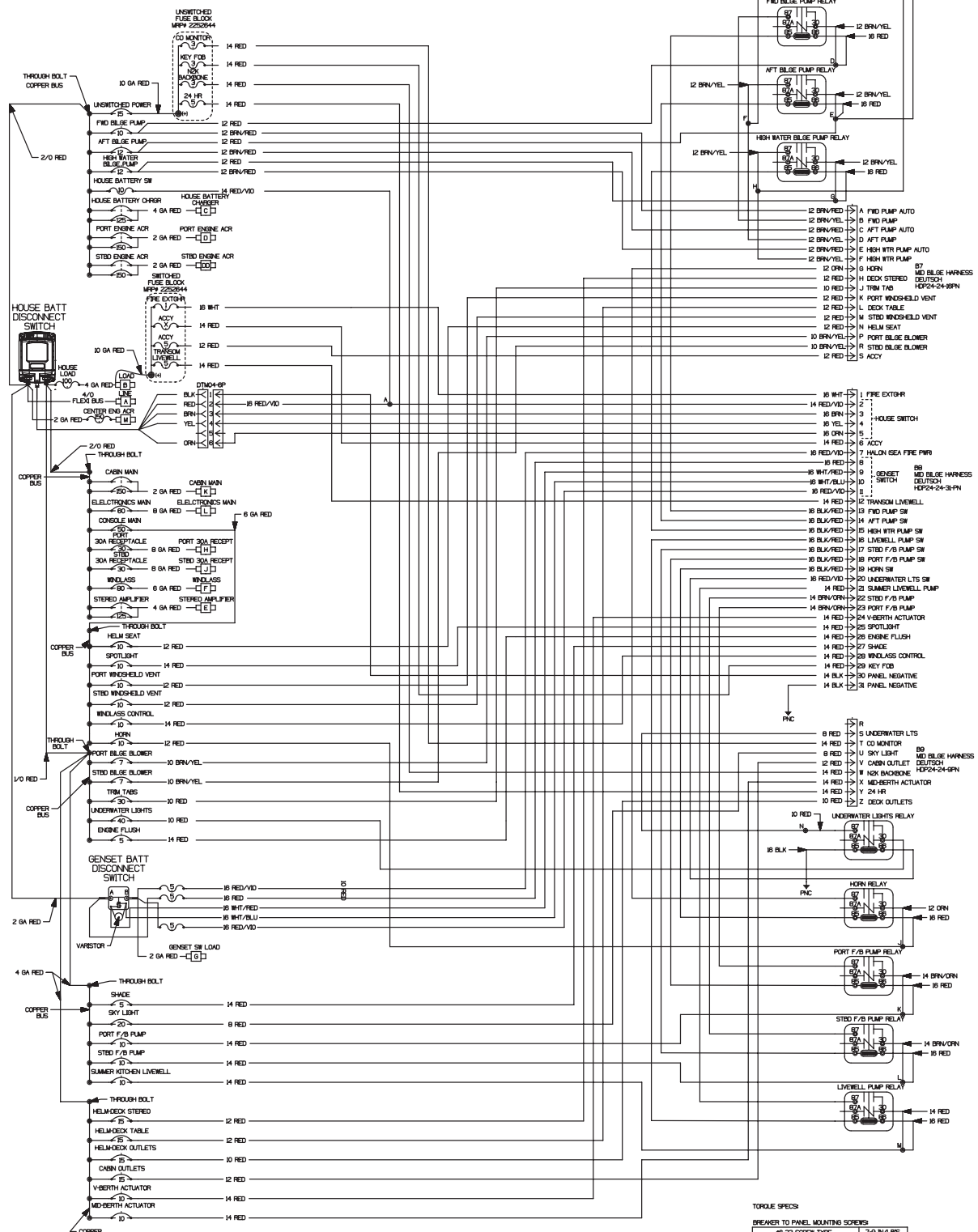

LEGEND
 ↓ PNC = PANEL DC NEGATIVE CONNECTION
 ○ = SPLICE

- TORQUE SPECS**
- | BREAKER TO PANEL MOUNTING SCREWS | |
|----------------------------------|------------|
| #0-32 SCREEN TYPE | 7-9 IN.LBS |
- A-SERIES BREAKER WIRE TERMINALS**
- | | |
|-------------------|--------------|
| #0-32 SCREEN TYPE | 10-15 IN.LBS |
| #0-32 SCREEN TYPE | 15-20 IN.LBS |
- C-SERIES BREAKER WIRE TERMINALS**
- | | |
|---------------------------|--------------|
| #0-32 SCREEN TYPE | 15-20 IN.LBS |
| #0-32 STD TYPE | 15-20 IN.LBS |
| 1/4" STD TYPE (INNER NUT) | 15 IN.LBS |
| 1/4" STD TYPE (OUTER NUT) | 30-35 IN.LBS |

Chapter 4 • Electrical

Main Breaker panel 240VAC 60Hz Wiring Schematic
(FIGURE 4.73.1)

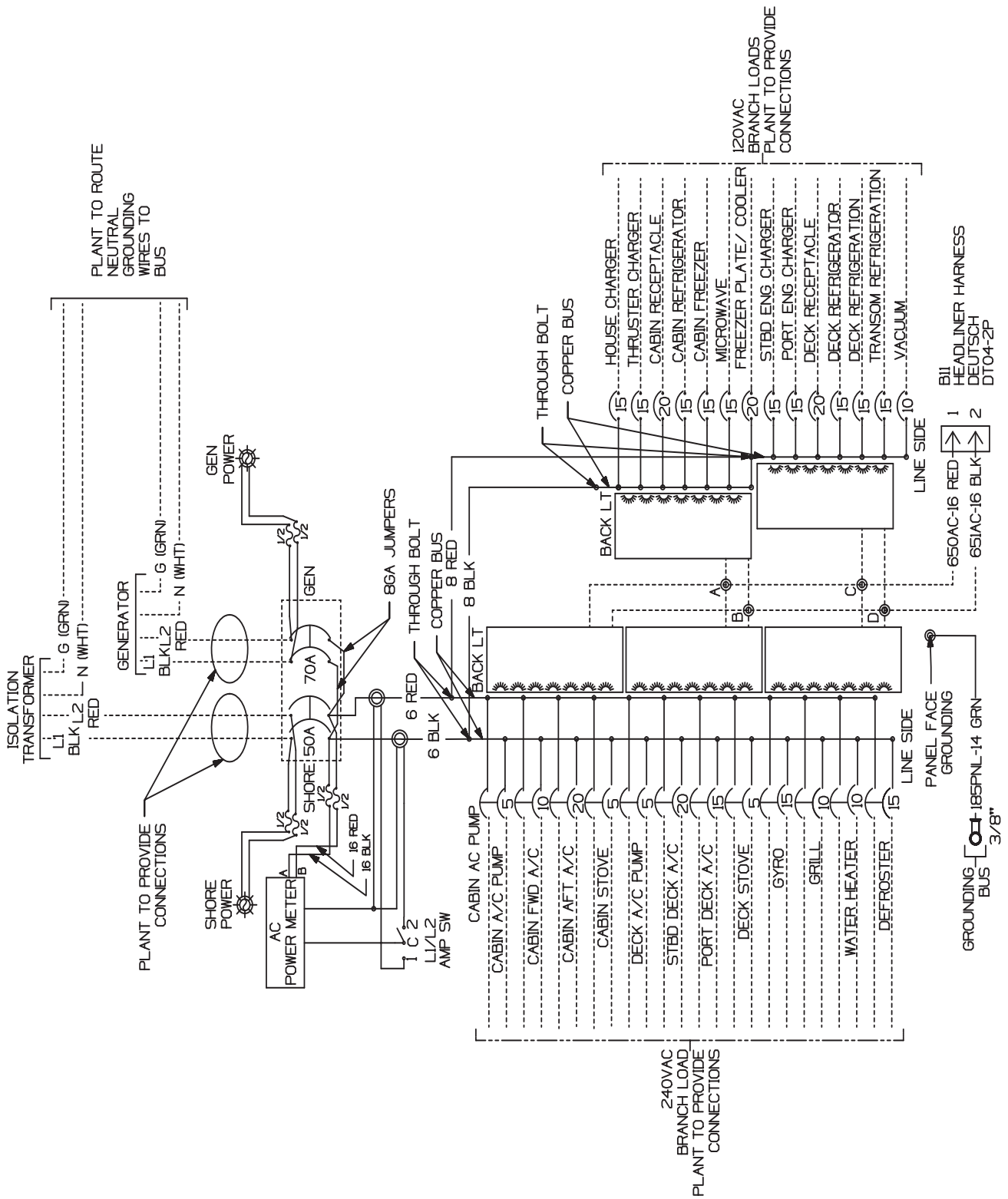

6029-07-401_29_I

Main Breaker Panel 230VAC 50Hz
(FIGURE 4.74.1)

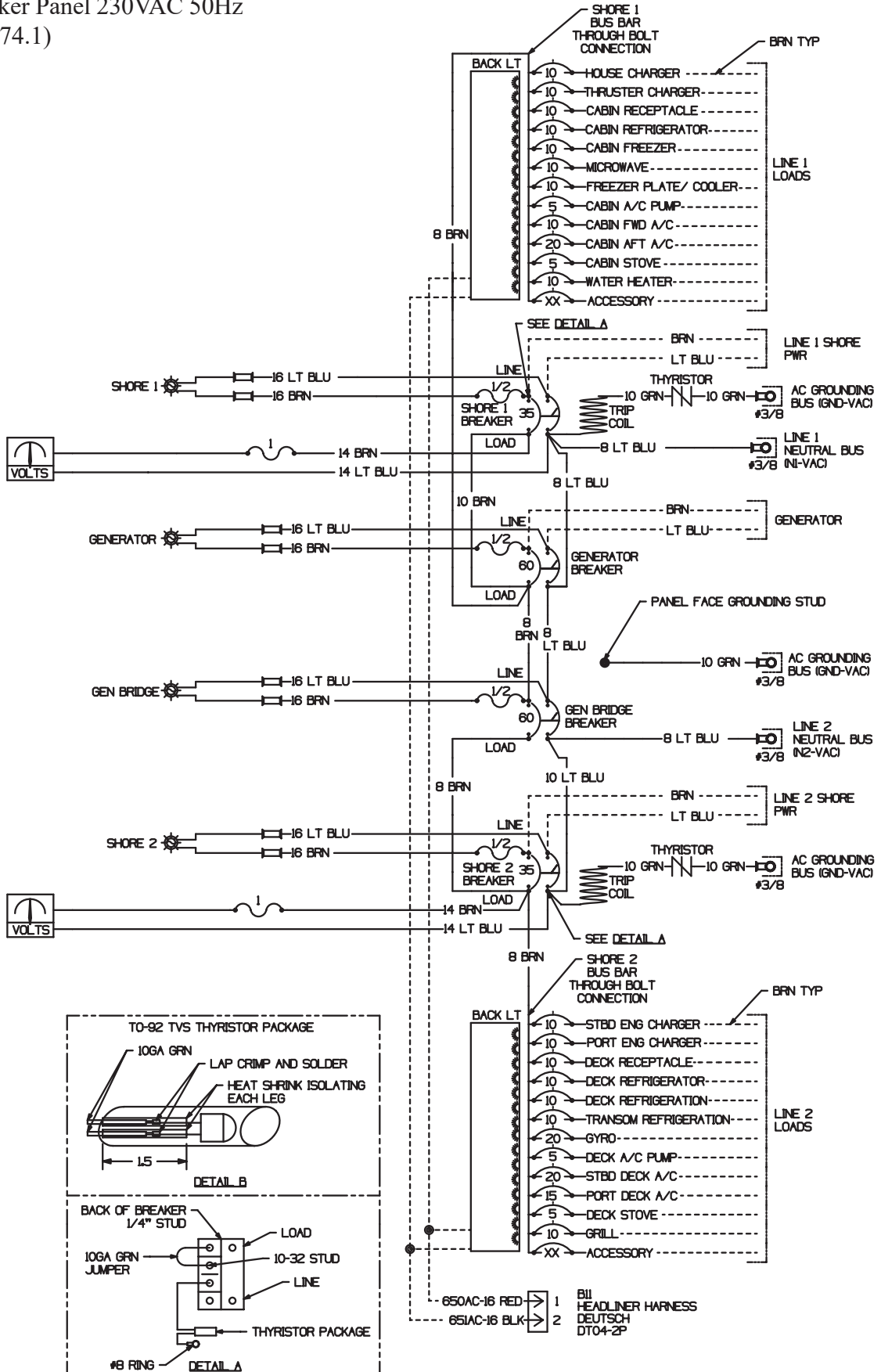

6029-07-401_30_I

Chapter 4 • Electrical

Port Engine Breaker Panel
(FIGURE 4.75.1)

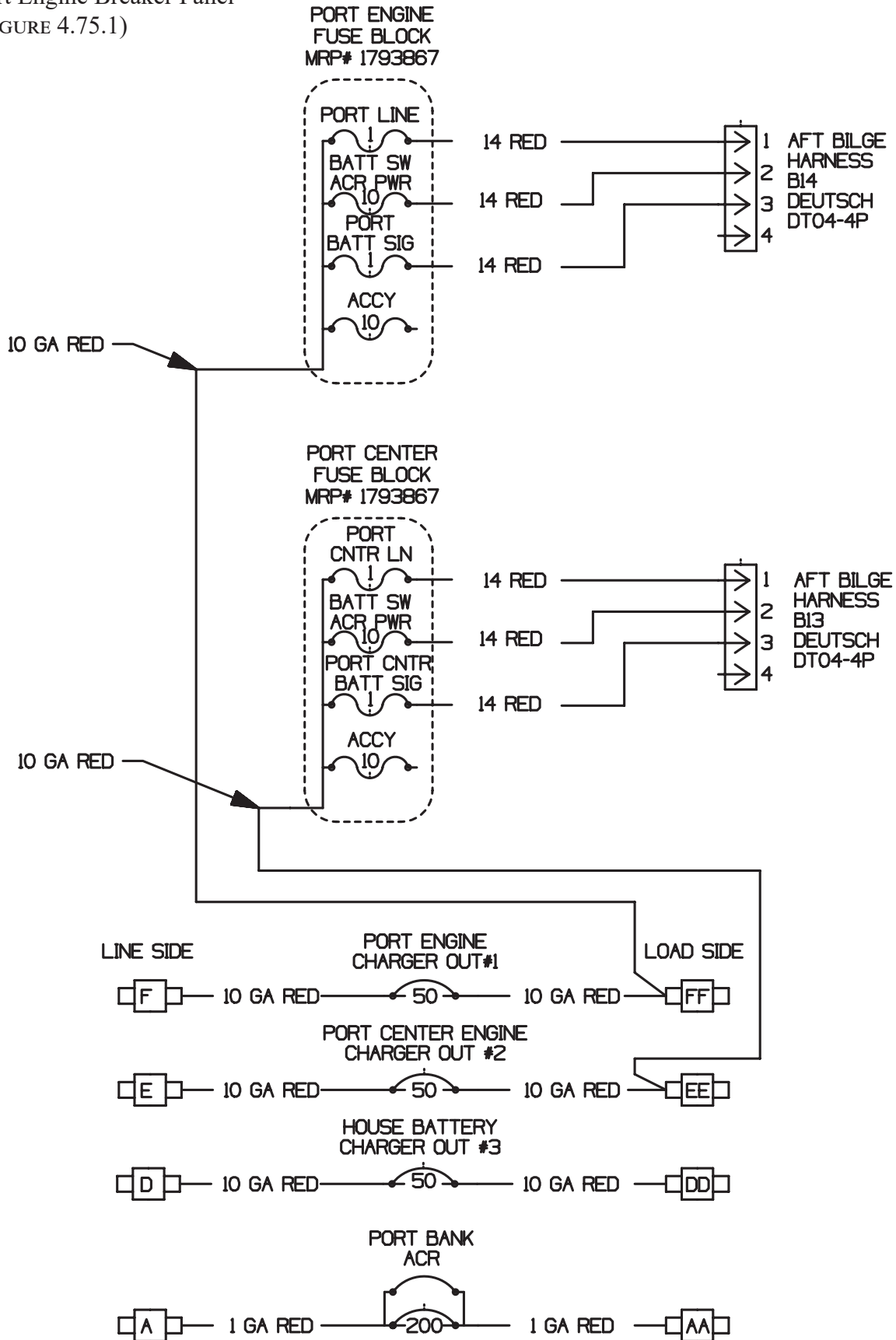

6029-07-401_31_I

Starboard Engine Breaker Panel
(FIGURE 4.76.1)

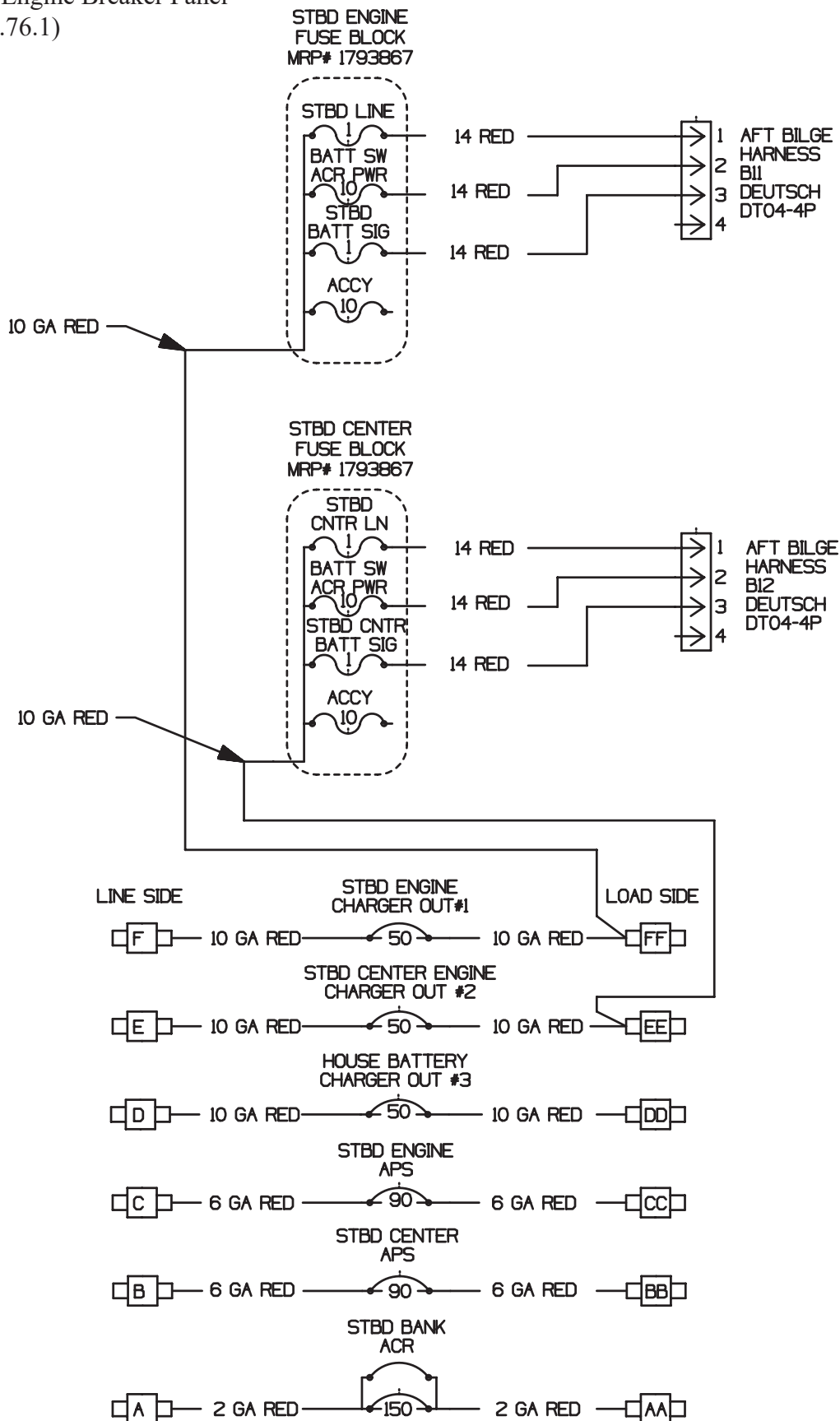

6029-07-401_31_I

Starboard Helm Switch Panel
(FIGURE 4.77.1)

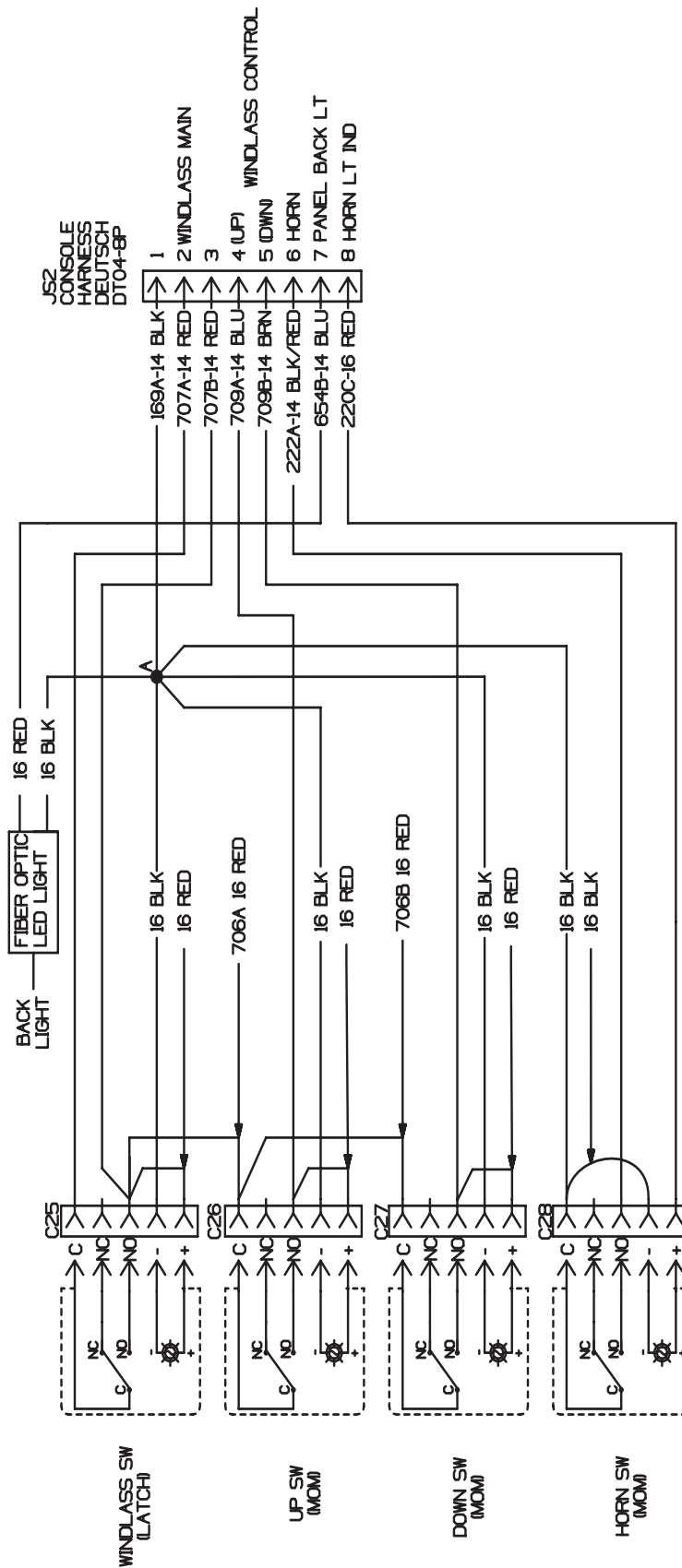

6029-07-401_32_I

Port Helm Switch Panel
(FIGURE 4.78.1)

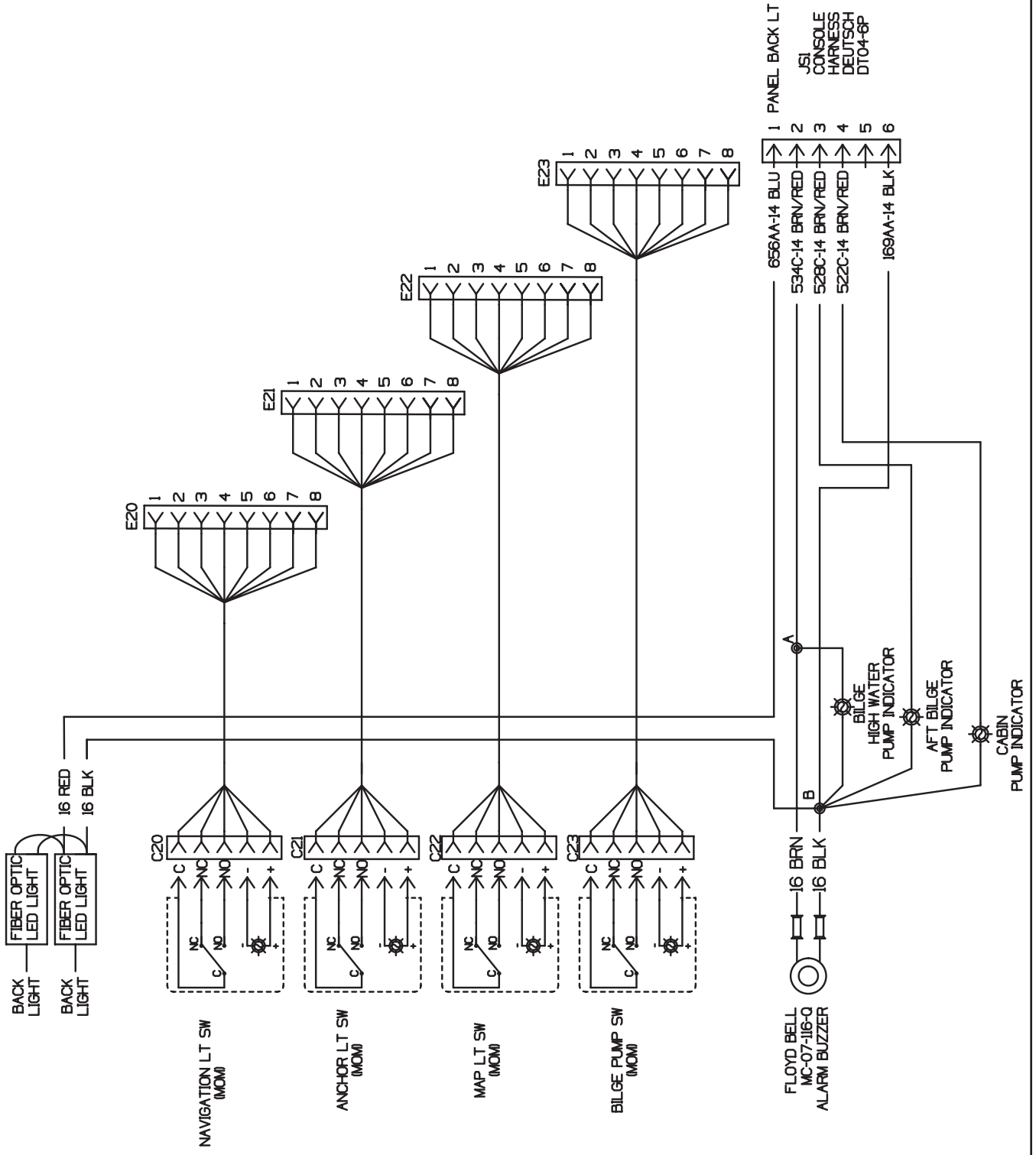

6029-07-401_32_I

Wiper and Helm Seat Switch Panel
(FIGURE 4.79.1)

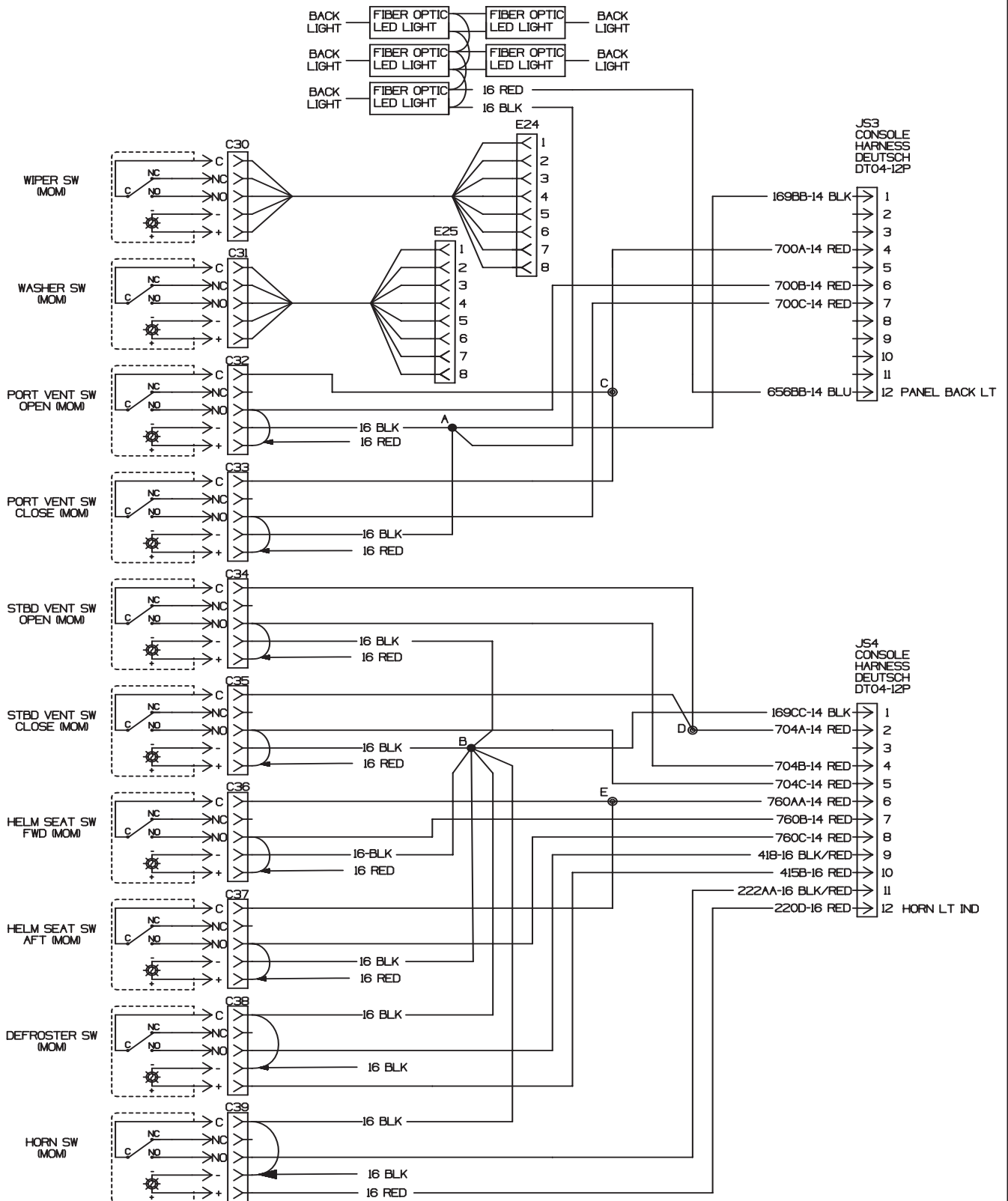

6029-07-401_33_I

Chapter 4 • Electrical

Triple Engine Breaker Panel (Option)
(FIGURE 4.81.1)

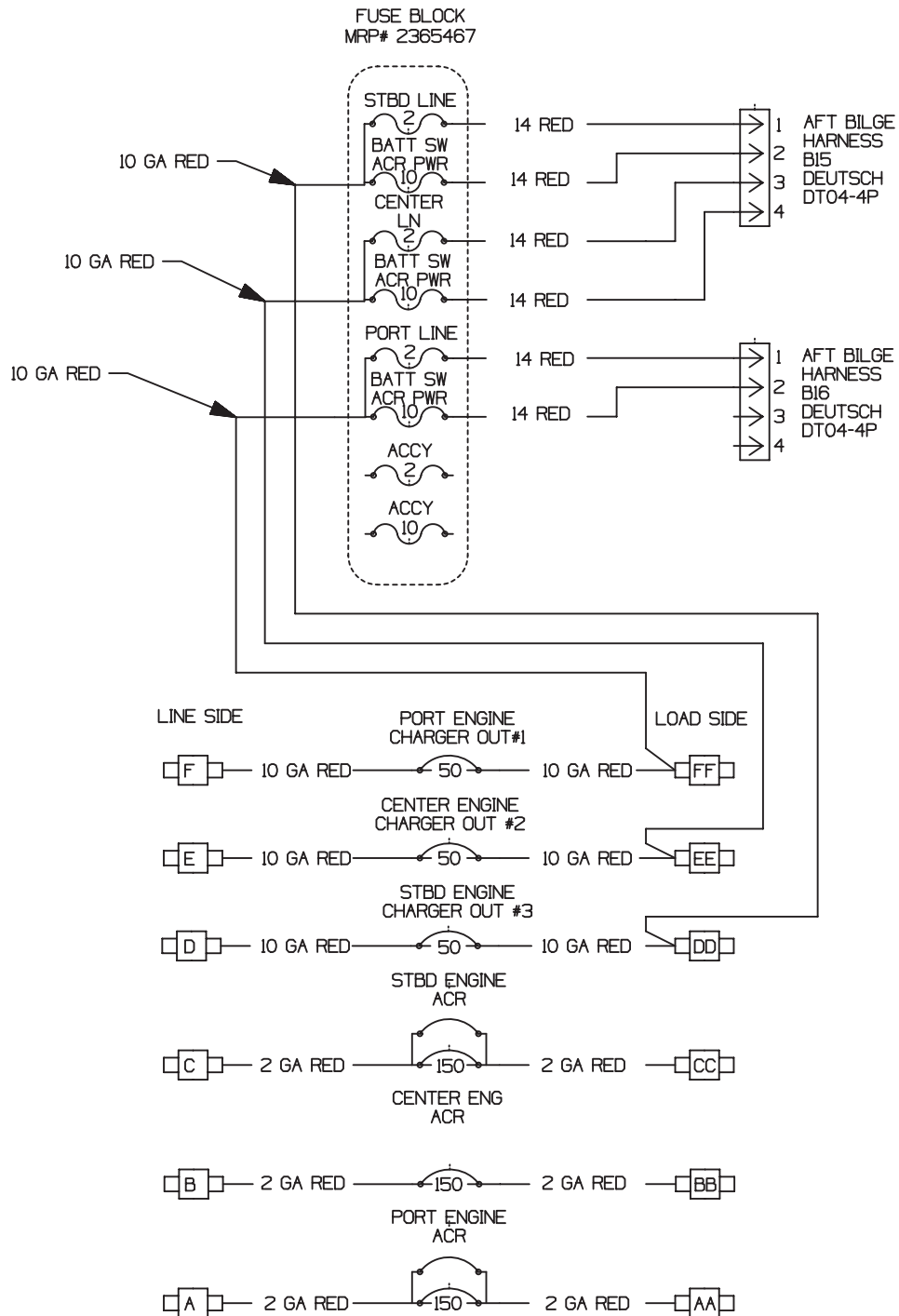

6029-07-401_35_I

Upper Station Helm Panel (Option)
(FIGURE 4.82.1)

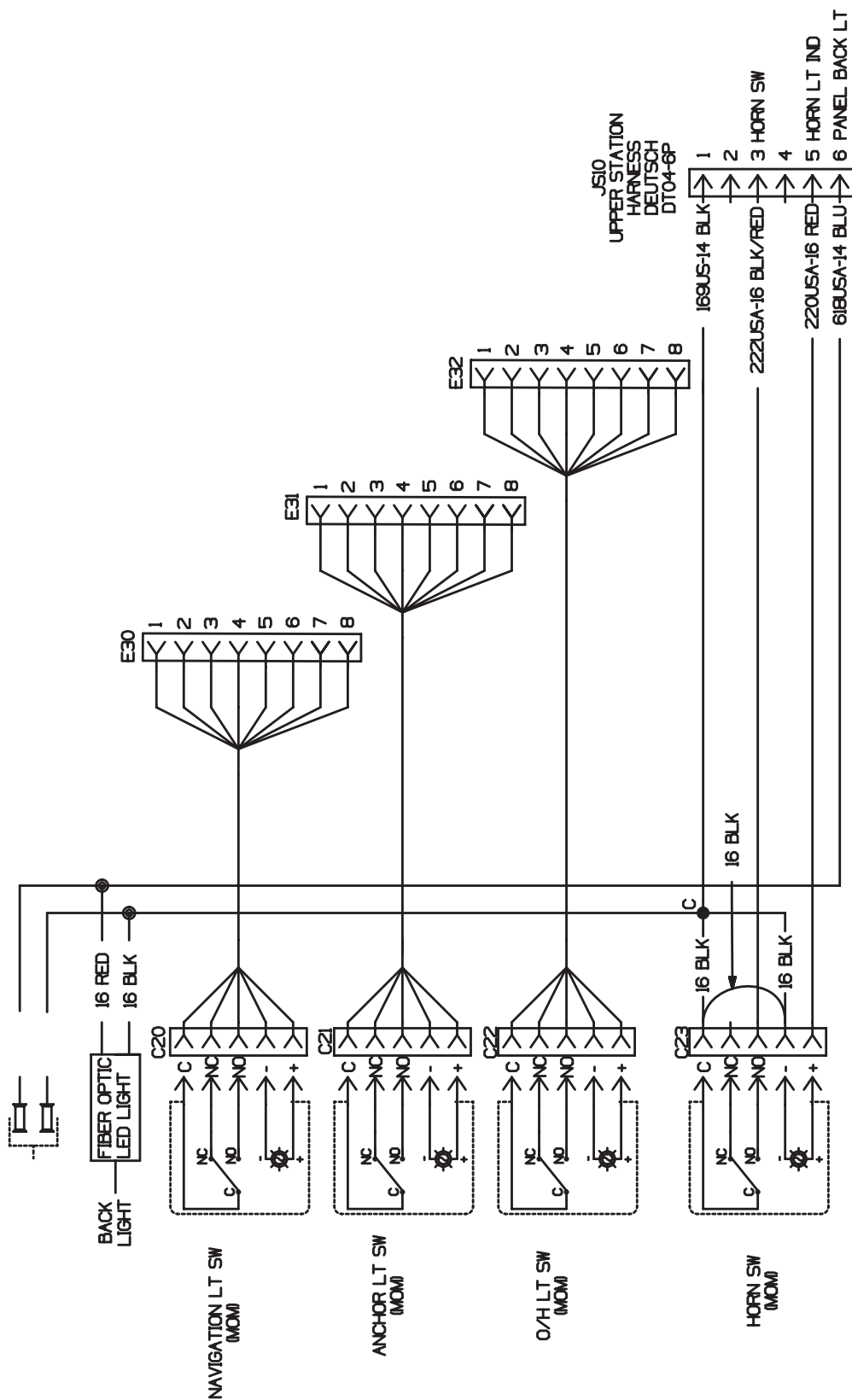

6029-07-401_36_I

Quad Engine Main Negative Bonding and Grounding Schematic
(FIGURE 4.83.1)

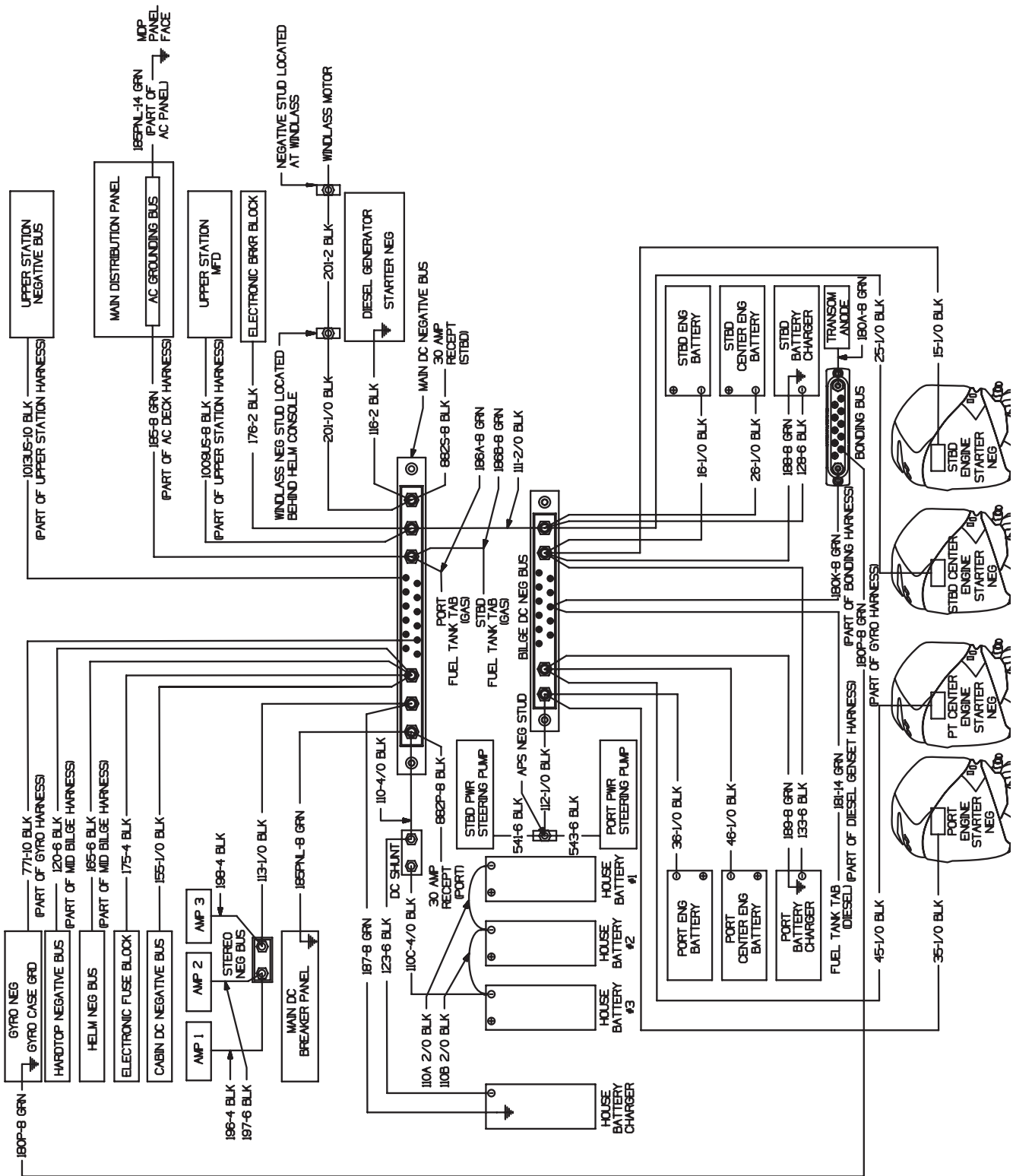

6029-07-402_1_D

Triple Engine Main Negative Bonding and Grounding Schematic
(FIGURE 4.84.1)

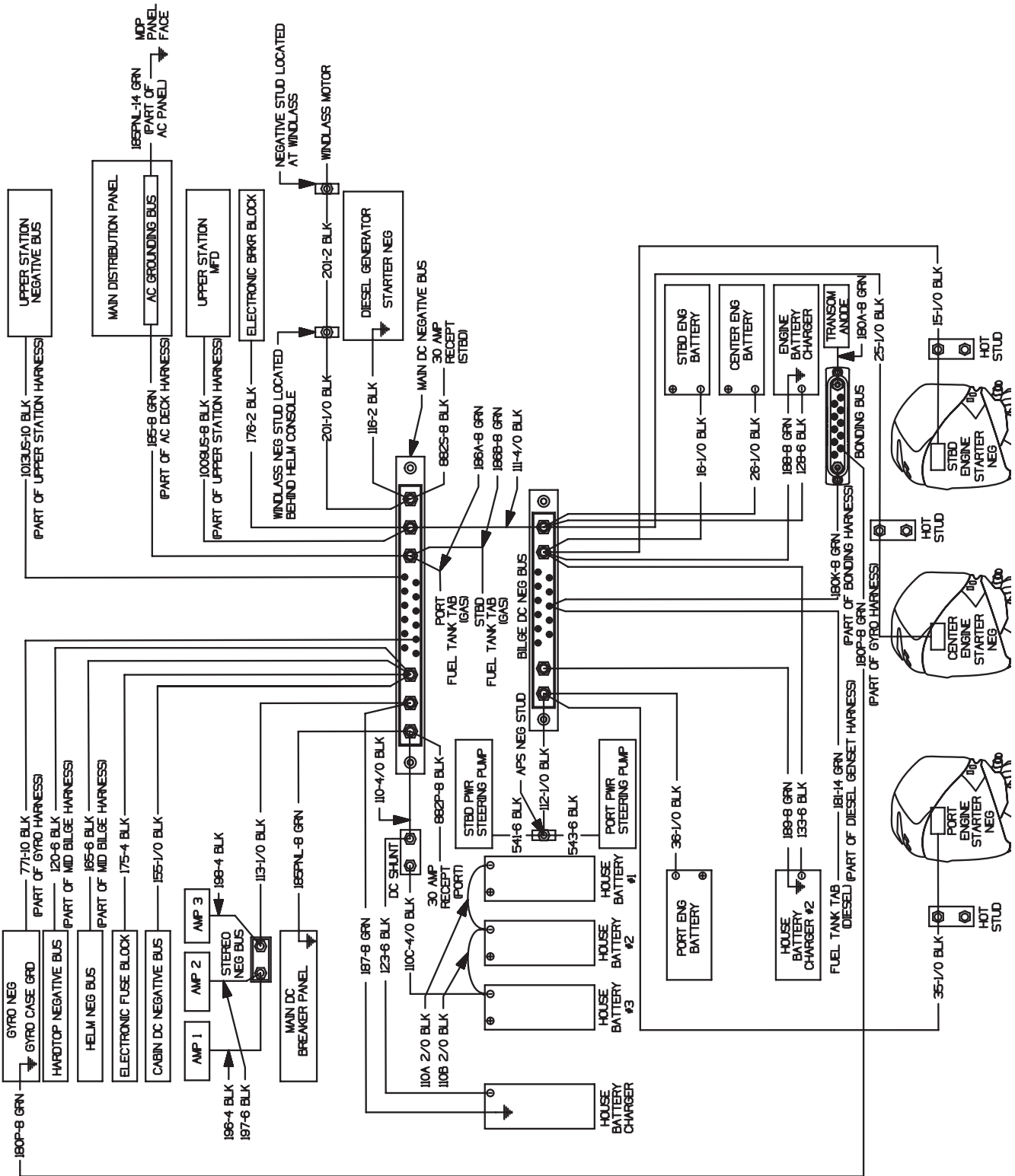

6029-07-402_2_D

Joystick Quad Engine Diagram
(FIGURE 4.85.1)

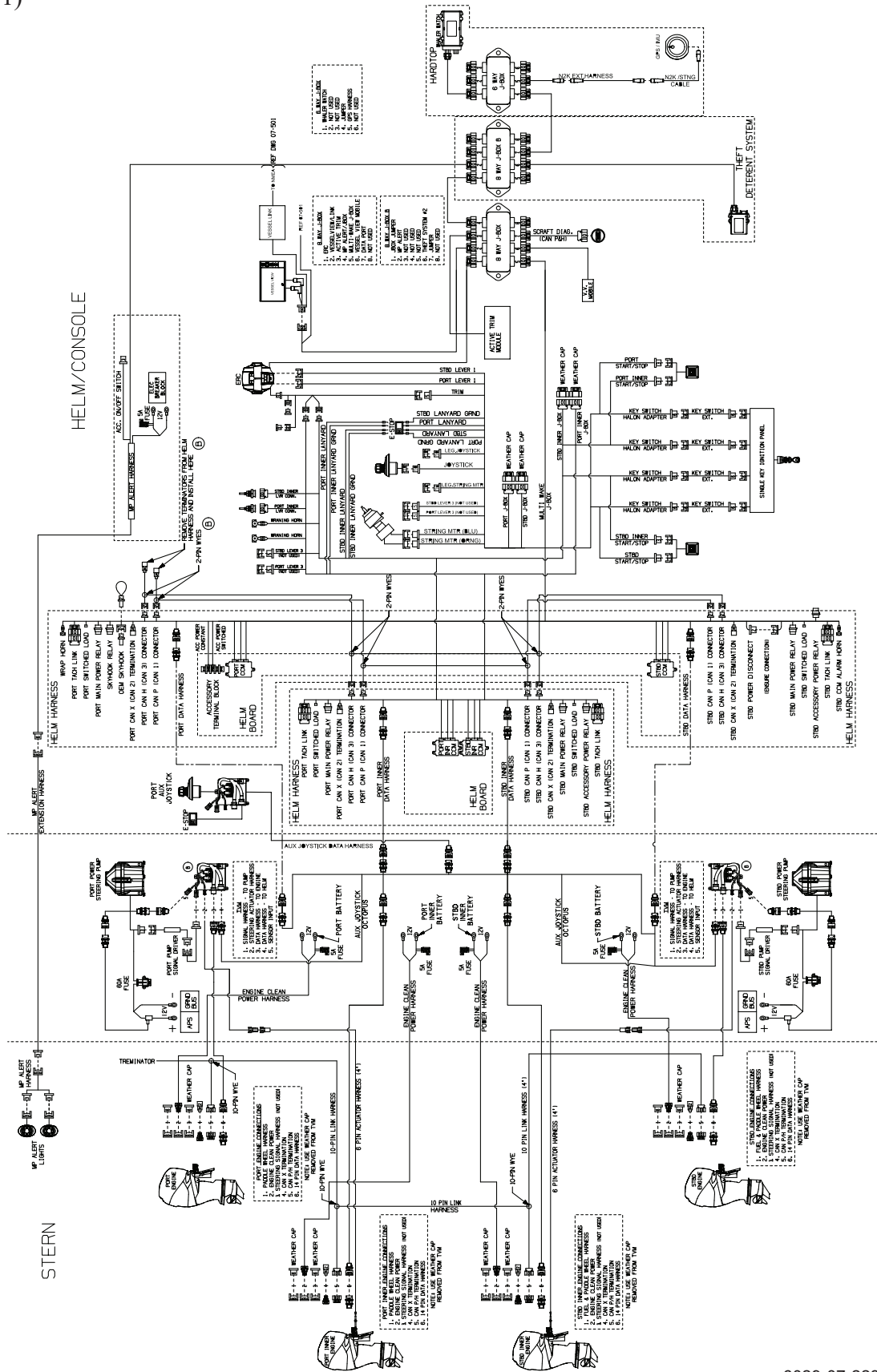

6029-07-223_1_C

Routine Care and Maintenance

NOTICE

Refer to the individual manufacturers' manuals for important information regarding service, care, and maintenance of this vessel's equipment and components. Failure to do so may in some cases void the warranty.

REFER TO THE OWNER'S PACKET FOR COMPLETE INSTRUCTIONS AND WARRANTY INFORMATION.

⚠ DANGER

When using solvents read all information from the solvent manufacturer regarding safe handling of the material.

Wear proper protective equipment to ensure your personal safety.

Only use solvents in a well-ventilated area and keep all solvents away from open flame and any other forms of ignition.

⚠ WARNING

Regularly inspect and test hardware, fittings, windshields, hatches, seams, etc., for proper seal. Reseal and/or readjust/tighten as needed.

Routine inspection, service, and maintenance of this vessel, systems, and components are vital to assure your safety, as well as prolonging the life of this vessel. Develop regular routines for inspecting and servicing this vessel.

The interval between necessary service or maintenance is highly variable, depending on the environment where the vessel is used. For example, corrosion of boat parts and components occurs more rapidly in a salt water environment than in fresh water.

This chapter provides only general guidelines for the care and cleaning of this vessel. It is your responsibility to determine whether maintenance and care intervals need to be accelerated due to boat usage and/or operating environment.

Hull

Fresh water, saltwater, and water temperature can all affect the types of growth on this vessel's hull.

Any growth affects the boat's performance and overall look. If it has been a while between inspections you might notice algae or slime growth on the hull. This can be cleaned with a coarse towel or soft bristle brush. The growth should be cleaned immediately after the boat has been removed from the water. If the growth is allowed to dry it will be much harder to remove.

Compounding may be necessary to remove more stubborn stains and chalking from the boat's surface. If compounding is necessary it must be done after a thorough washing and prior to waxing.

If the growth is more severe, you may need to enlist the services of a professional hull-cleaning company.

Check with a Boston Whaler® dealer for recommendations on a compatible rubbing compound for this vessel or a professional hull cleaning service.

Aquatic Invasive Species (AIS)

Aquatic invasive species (AIS) are plants and animals that occur in waters in which they are not native and whose introduction causes or is likely to cause economic or environmental damage or harm to human health. AIS have a negative impact on the waterway, its native species, and recreational and commercial uses of the waterway.

As responsible boaters and citizens, each boat owner should do their part to prevent the spread of these aquatic hitchhikers. In many cases, it is also required by law. Check local regulations for any waterway where you will boat.

After each boating trip, follow these three simple steps before you leave the water access to stop the spread of AIS: Clean, Drain, and Dry. This is the boater's way to help protect the environment from the damage that AIS can cause.

Clean

Inspect and remove all aquatic plants, animals, mud, and debris from the boat, engine, trailer, anchor, and any watersports equipment.

Rinse, scrub or wash, as appropriate, away from storm drains, ditches, or waterways.

Rinse watercraft, trailer, and equipment with hot water, when possible.

Flush motor according to owner's manual.

Drain

Completely drain all water from the boat and its compartments, including but not limited to the bilge, wells, lockers, ballast tanks or bags, bait containers, engines, and outdrives.

Dry

Allow the boat to completely dry before visiting any other bodies of water.

NOTE: Some localities may require inspection or decontamination before and/or after launching. Check state and local laws and regulations for requirements prior to traveling to go boating.

Waxing Gel Coat Surfaces

NOTICE

Waxing of the exterior surfaces is recommended to be done at least twice a year to protect the gel coat of this vessel.

Waxing is necessary to provide added protection to the gel coat. A periodic good cleaning and waxing will also ensure that this vessel will be protected and look good longer.

Do not wax over dirt. Make sure the surface of this vessel has received a thorough washing and rinsing and is clean before waxing. If a rubbing compound has been necessary, make sure that any minor scratches or surface pitting are free of compound residue. Use a good quality carnauba wax or a high-quality wax designed for marine gel coat. Apply several coats.

Hull Maintenance

If using a pressure washer to clean the hull and deck surfaces of this vessel it is important to use the wide fan nozzle only and move the spray head in a continuous motion. Do not concentrate the high pressure on a small area of the boat surface and never use the fine pinpoint nozzle as the concentrated stream can cause damage.

Do not pressure wash the helm console as this may compromise the integrity of the electronics and gauges as well as other equipment installed on this vessel. Also avoid pressure washing all caulk seams.

When staining from build-up does occur, use only cleaning agents recommended for use on marine gel coat. Never use an abrasive cleaner to wash this vessel's hull. Never use an abrasive pad to attempt to remove stubborn stains. Never use strong solvents to clean. Never apply tape or any other type of adhesives directly to the painted surfaces on this vessel. Use care when covering this vessel's painted surfaces as tarps and other such covers can trap dirt and cause chafing. It is best to use a frame of either aluminum or wood to keep the cover raised and allow air to circulate.

Hull Blistering

Due to the quality of the materials used in the hull, blistering is rarely ever seen. Blistering is caused by water soluble materials in the hull laminate. The fiberglass and resin structure of this vessel is porous. However, intrusion of water into the gel coat will take some time. The effect of osmotic pressure allows water to impregnate below the gel coat and substrate thus forming a blister.

There have been extensive university studies funded by the United States Coast Guard regarding the cause and effect of blistering in the gel coat of fiberglass boats. Fiberglass blisters can form anywhere from near-surface layers of the gel coat to very deep into the fiberglass structure. Damage can range from cosmetic to catastrophic, although the latter is very rare. Studies seem to point to long-term immersion of the hull in warm water as a primary cause of hull blisters. Stress cracks on the hull below the waterline also contribute to the formation of hull blisters.

Prevention

There are a variety of ways to prevent the formation of hull blistering. Epoxy coatings can be applied to hulls, followed by hull painting. An alkyd-urethane-silicone marine paint can also be used to aid in the prevention of hull blisters.

Reducing the amount of time that this vessel stays in the water also helps prevent hull blisters from

forming. Use of a trailer or boat lift reduces the likelihood of hull blisters forming. Be sure to use a bunk type lift or trailer for storage of the boat out of water. Contact a Boston Whaler dealer for more information on hull blister prevention and treatment.

Sacrificial Anodes



CAUTION

Do not paint over sacrificial anodes. This action renders them useless and leads to deterioration of the underwater metal parts of this vessel.

Sacrificial anodes are installed on this vessel's hull, trim tabs, and engines to protect metallic parts from corrosion damage.

Anodes must be replaced regularly. Inspect anodes often and replace when the anode is approximately 50 percent deteriorated. If an increase in anode consumption is noticed, there may be an electrical issue that needs to be addressed on your vessel or a neighboring boat at the dock. Contact a qualified marine electrician.

Deck

Clean up any oil spills on the deck with soap, hot water, and a stiff brush.

Bottom Painting



DANGER

There are risks and dangers inherent with the use of paints and solvents. Dispose properly of all rags, rollers, and trays used for painting. Follow all the precautions and regulations listed by the manufacturer before and after painting this vessel's hull.



CAUTION

Some bottom paints contain metals that can cause corrosion of outboard engines. Leave a minimum of 3/4" unpainted surface around all engine parts. Use only paints specifically designed for aluminum engines as anti-fouling protection.

NOTICE

If blisters are present in the hull, they need to be properly cleaned and dried out before any barrier protection can be applied.

If this vessel will spend most of its time in the water, painting the bottom of this vessel's hull is a good way to slow the formation of hull blisters and to keep bottom growth (fouling) under control. Conversely, if you will be trailering the boat to and from the water, you might want to forgo the painting.

The following is an abbreviated section on painting the hull bottom. Your Boston Whaler dealer should have information on properly painting this vessel's hull or recommendations on businesses that specialize in this area.

Bare Hull Painting



WARNING

Proper ventilation and capture of the dust created by sanding is essential. The dust created by sanding is toxic and should not be inhaled. A proper fitting respirator must be used. Do not use a paper filter mask.

Proper preparation is the key to successful hull painting. Begin by scrubbing the surface thoroughly with a stiff brush using an all-purpose marine soap and water to remove loose dirt and contamination. Flush with fresh water to remove all soap residue.

The gelcoat must be dewaxed of mold-release wax before sanding can begin, otherwise wax will be deposited in the scratches and reduce the adhesion properties of the paint.

Remove any mold-release wax that may be present using fiberglass surface prep solvent and a scrub pad. Scrub only a few square feet at a time. Flush with fresh water. If the water beads up or separates, continue scrubbing the surface. When the water sheets off, the wax contaminate has been removed.

After the dewaxing is complete, application of a primer coat is recommended. Pay close attention to scratches, nicks and dings in the surface. If necessary, fill any repair areas with a watertite-epoxy filler. After

filler is cured, sand with 80 grit paper until smooth. Remove the sanding residue using a fiberglass solvent wash. Paint can be applied after sanding and cleaning is complete. Follow the paint manufacturer's recommendations for application.

Bottom Painting a Pre-Painted Hull

WARNING

Bottom paint is designed to resist algae growth which means it has chemicals embedded in the paint that are harmful if ingested. Take all necessary precautions required before painting or repainting this vessel's hull.

NOTICE

Painting this vessel's hull will adversely affect the boat's speed and performance and may require re-propping if the maximum engine RPMs drop below the engine model/manufacturer recommended operating range.

NOTICE

The use of masking tape is not recommended for hull-bottom paints.

If the hull bottom is already painted, test the paint's adhesion to the painted surface. If the paints are incompatible, the new paint will not adhere to the hull bottom or the paint will lift the old paint. Never apply paint without first preparing the old painted surface. Follow the paint manufacturer's recommendations. Thin layers are better than one thick layer.

Humidity and weather play a role in how and when paint should be applied. To determine the waterline, place the boat in water with a full load of fuel and gear. Mark the waterline and measure above the marked line 1 inch to 3 inches for placement of the tape line. Make sure that there is enough paint left to cover areas that were not accessible (slings, jack stands etc.) and paint accordingly. Follow the paint manufacturer's recommendation for do's and don'ts after painting is complete.

Rubrails

The rubrail on this vessel is constructed of an injected high density PVC vinyl material which laboratory tests have proven to be highly resistant to staining, fading and cracking. As resilient as this material is, you still need to follow some basic maintenance precautions. General maintenance requires a thorough cleaning with mild soap and water. Do not use any cleaning agents which contain chemicals.

Although the outer shell is tough and durable, there is a chance that it can be breached. Use care when docking or exposing the rubrail to conditions which may cause damage such as docking against heavily barnacle-encrusted pilings. Some tears (cleanly sliced) can be repaired with a super glue-type product. Thoroughly clean and dry the affected area. Apply glue and hold the surfaces together. Areas which have been torn or are affected by heavy abrasion must have the damaged section replaced. Please see a Boston Whaler dealer for this type of repair.

Cleaning Fiberglass and Non-Skid

NOTICE

Never use abrasive cleaners, detergents or soft scrub type cleaners to wash this vessels surfaces.

Never use abrasive pads, brushes or sponges to attempt to remove stubborn stains.

Never use strong solvents or detergents which contain chlorine.

Never use silver cleaners.

To protect this vessel's deck and non-skid areas from the deteriorating affects of the sun, oxidation, water spots, and pollution, use a good quality fiberglass and non-skid deck wax every two to three months. When applied to deck and non-skid areas the wax forms a protective non-slick surface which keeps debris from sticking. Dirt, soot, bird droppings, and fish blood rinse right off. Follow the wax manufacturer's detailed instructions.

Stainless Steel

To ensure optimum corrosion resistance of stainless trim and fittings, clean and maintain them regularly. Stainless steel is strong and corrosion resistant, but

still requires maintenance to keep its appearance. Frequent routine cleaning of stainless steel with a mild soap and water solution - and coating with a quality cleaning wax - helps maintain the finish. To maintain:

1. Wash with mild soap and cold water.
2. Dry thoroughly.
3. Apply cleaning wax with a soft, dry cloth.
4. Allow wax to dry, then polish and buff.

Cleaning powders can scratch or burnish a mill-rolled surface. On polished finishes, rubbing or wiping should be done in the direction of the polish lines, not across them.

Crevice corrosion, a brownish coloring which occurs where two pieces of stainless hardware meet, is caused by impurities in water and air. It can be easily cleaned with a marine-grade polish using a sponge, cloth or small bristled brush in the nooks and crannies.

Teak Maintenance

The teak on this vessel requires some maintenance. Boston Whaler uses both natural teak and coated teak (pre-lacquered). Do not use a steel brush, steel wool, or a pressure washer on the wood. Do not use strong solvents or harsh cleaners on the caulking as these can damage or dissolve the caulk. Depending on the options selected for this vessel, different maintenance options apply:

Let It be (Natural Teak)

Left alone with the elements, teak changes to a silver-grey patina. To maintain, occasionally wash with soap and water. A light sanding every few years keeps the surface smooth; always sand with the wood grain.

Oiling

To retain or increase the darkness of the wood, apply a teak oil. There are numerous products on the market that provide a variety of different characteristics. Refer to the manufacturer's instructions for proper application.

Lacquering

Applying lacquer to teak may decrease the amount

of maintenance required and reduces the risk of mold. Lacquers can be tinted to change the color of the finish and can be mixed with paint thinner to reduce shine. Wood will likely darken when clear lacquer is applied. Carefully research product information to ensure it's suitable for both teak and caulk. Refer to the manufacturer's instructions for proper application.

Coated Teak (Pre-lacquered)

If this vessel has a coated (pre-lacquered) table(s), keep covered when not in use. Be sure to allow for air flow between the table and the cover by inserting a non-marring object between the two. Refer to the manufacturer's instructions for proper care.

Seats (Mechanical Parts)

Always wash metallic parts with soap and water, and rinse thoroughly with clean water. Once dry, apply a light coating of lubricant to protect moving parts. Check for loose or damaged hardware and tighten or replace as necessary.

Aluminum

Preventative maintenance is essential to the life of the metals on this vessel. The presence of salt particles and moisture is the major cause of white spots, pitting and corrosion. The use of harsh chemicals can also cause deterioration. Manufacturers and applicators of protective coatings will not warranty protective coatings on metals in the marine environment. Proper owner maintenance is required to reduce deterioration which results in most cases by failure to wash down and wipe dry after each use and/or the use of abrasive, acidic or other improper cleaners.

Wash completely using a soft cloth and mild detergent to remove salt particles. Hosing alone will not dislodge all particles. Do not allow soap to dry as it may cause stains on coated surfaces. Make sure to wash and dry the full circumference of aluminum parts.

Apply an aluminum protectant at least twice each year - more frequently as conditions warrant. Neglect causes surface pitting which cannot be reversed.

Inspect and repair or replace all damaged nylon bushings, washers or other hardware designed to prevent contact with dissimilar metals.

Whenever electrical or electronic changes are made to the boat, a qualified-marine technician should check aluminum parts for stray currents. Make sure all electronic equipment is properly grounded with adequately-sized wire.

Standard Vinyl Cushions

Saltwater, salt residue, dirt and ultra-violet rays will take their toll on vinyl products causing them to lose their luster and texture. To clean standard cushions:

- Remove ordinary dirt and smudges with a mild soap and water solution. Dry with a soft, lint-free cloth or towel.
- More difficult stains can be cleaned using rubbing alcohol. Rinse cleaned area with fresh water and dry with a clean, soft, cloth or towel.
- Seemingly permanent stains like ballpoint ink can be cleaned with active solvents such as nail polish remover when applied with a soft cloth or damp sponge and rubbed. Rinse cleaned area with fresh water and dry with a clean, soft, cloth or towel.

CAUTION

Wear rubber gloves when using any solvents. Use caution when cleaning around buttons, stitching, and wooden or decorative trim as solvents could seriously damage such areas.

REFER TO THE OWNER'S PACKET FOR COMPLETE INSTRUCTIONS AND WARRANTY INFORMATION.

Cool Technology Vinyl Cushions (Option)

If this vessel is equipped with cool technology vinyl seat cushions, clean this material per the manufacturer's instructions at <https://spradling.group/en-sm>

Water Exposure

Boat cushions are not waterproof and will absorb and hold water. Do not leave the cushions in standing water or exposed to heavy, prolonged rain. If cushions become waterlogged, remove the foam from the cushion, press out as much water as possible from the foam and allow to air dry. To prevent mildew, keep the vinyl dry and make sure that moisture does not accumulate between the cushions.

Instrumentation Cleaning

When gauges are exposed to a saltwater environment, salt crystals may form on the bezel and plastic covers. Remove salt crystals with a soft damp cloth. Clean with a mild household detergent or plastic cleaner. Never use abrasive solvents or dirty rags to clean plastic parts. A mild household detergent or plastic cleaner should be used. Wipe clean with a damp chamois. For more information, contact Mercury customer service at 920-929-5040.

Canvas

NOTICE

Do not use detergents, bleach or solvents to clean your canvas.

To keep canvas in good condition it should be cleaned regularly before dirt, pollen, etc. are allowed to accumulate on and become embedded in the fabric. Canvas can be cleaned without being removed. Chafing, fiber wear from dirt and grit and deterioration from ultraviolet light can cause your canvas to degrade over time.

Maintaining Appearance

After each use, especially if used in salt water areas, rinse the canvas completely with fresh cold water. To maintain canvas:

- Brush off any loose dirt, pollen, etc.
- Hose down with fresh cold water and clean with a mild solution of a natural soap in lukewarm water (maximum 100°F / 38°C).
- Allow canvas to soak. Do not allow soap to dry.
- Rinse thoroughly with fresh water.
- Let canvas dry completely. Do not store canvas while wet.

The effects of ultraviolet light can sometimes be reduced by chemical treatment of canvas items. Consult a Boston Whaler dealer or check the canvas manufacturer's instructions before using any chemical treatment on canvas.

REFER TO THE OWNER'S PACKET FOR COMPLETE INSTRUCTIONS AND WARRANTY INFORMATION.

Stubborn Canvas Stains

NOTICE

Failure to remove all of the soap solution can cause deterioration of seams and prevent fabric from proper retreating.

Soak fabric for approximately twenty minutes in a mild solution consisting of no more than 1/2 cup of bleach and 1/4 cup of natural soap per gallon of lukewarm water (not to exceed 100° F / 38° C). Rinse thoroughly in cold water several times. Allow the fabric to air dry completely. Retreat the fabric using an air-curing product such as *303 High Tech Fabric Guard* to ensure water and stain repellency. All canvas should be stored flat or rolled in a clean, dry space.

Canvas Zippers

Lubricate zippers and fasteners periodically with a clear silicone spray. A wax candle can also be used to lubricate the zipper track. Replace any missing or corroded fasteners.

Vinyl Windows

NOTICE

Do not use petroleum based products, such as petroleum jelly, on the zippers or fasteners.

NOTICE

- **Never use window cleaners, detergents, abrasives, petroleum-based products, or alcohol to clean vinyl windows.**
- **Do not handle vinyl windows with sunscreen on your hands. Sunscreen permanently clouds vinyl where handled.**
- **Do not fold vinyl. Store flat or rolled with smooth paper or soft cloth (like a bed sheet) between layers when dry.**

The canvas on this vessel may incorporate Eisenglass or Makrolon® polycarbonate windows. Regular cleaning, utilizing compatible cleaners, coupled with proper maintenance improves the vinyl's service life.

- Rinse vinyl thoroughly with fresh water to

remove any dust, dirt particles, salt water or environmental agents before applying cleaning products. This should be done frequently to avoid build up of salt water, dirt and other environmental contaminants.

- Using a soft non-abrasive cloth, wash windows inside and out with a mild soap and water solution. Rinse completely with cool water.
- Do not use detergents.
- Use separate clean, soft cloths or sponges for application of cleaners and polishes. Use a small amount of cleaner or streaking may occur. If streaking or a film occurs, follow up application with a water rinse.

REFER TO THE OWNER'S PACKET FOR COMPLETE INSTRUCTIONS AND WARRANTY INFORMATION.

Tempered Glass Windshield

Use commercially available glass cleaners or a mixture of fresh water and vinegar to clean glass windows, windshield or port lights. Dry with a soft terry cloth towel or chamois.

Long-term Storage and Winterization

NOTICE

Do not use abrasives, harsh chemicals or metal scrapers on glass.

Long periods of storage, winter lay-up and/or non-use, common to boats, create unique problems. When preparing to store a boat for extended periods of two months or more it is best to make sure that the boat and its systems are properly conditioned for such extended periods of non-usage. Follow the guidelines on winterizing this vessel and the boat's systems. If inexperienced with the process of winterization it is best to hire the services of a professional.

REFER TO THE OWNER'S PACKET FOR COMPLETE INSTRUCTIONS AND WARRANTY INFORMATION.

Engines

CAUTION

Never start or run an outboard engine, even momentarily, without having water circulating through water intakes in gear case. This will prevent damage to water pump (running dry) or engine overheating.

Protecting your engine's vital moving parts from corrosion caused by freezing of trapped water or excessive condensation due to climatic changes is very important. Freezing water in the engine can cause extensive damage to the internal moving parts. Internal engine parts can also be affected by rust due to lack of proper lubrication. To maintain:

- Replace engine oil and filter, running the engine to drain as much old oil as possible.
- Flush engine with fresh water using flush mufflers or similar device attached to raw water pickup.
- Let all water drain from engine.
- Fog engine while running. Spray until it stalls.
- Run fuel which has been treated with conditioner and stabilizer through engine.
- Replace lower unit gear oil. Check for moisture in old oil, a sign of deteriorating seals.
- Remove prop and grease shaft and threads.
- Treat all grease fittings with manufacturer-recommended lubricant.
- Lightly lubricate exterior of engine or polish with a good wax.
- Check engine mount bolts. Ensure they are torqued to 55 ft/lbs.
- Fill tank to capacity; add fuel stabilizer/conditioner.

REFER TO THE OWNER'S PACKET FOR COMPLETE INSTRUCTIONS AND WARRANTY INFORMATION.

Fuel System

Treat tank(s), hoses, and fuel pumps to help prevent the formation of varnish and gum. Temperature extremes will cause condensation to accumulate in an empty or partially-filled fuel tank leading to fuel

contamination and/or premature wear of your system.

Inspect your fuel system annually for leaks. You should check the fuel-tank area below the floor for liquid fuel, or a strong odor of gasoline before each outing, but at least once a year you should open each access port to any of the fuel-system components to inspect for leakage. If any leakage or seeping of fuel around any fuel-system fitting is found, or there is a strong odor of gasoline, do not turn on or off any electrical appliances or attempt to start this vessel; open all hatches to allow the compartment to ventilate, and call a qualified service/repair person for inspection and repair of the leak before using boat.

Freshwater System

If the freshwater system won't be used for an extended amount of time it is recommended that it be drained. To drain:

- Press *Freshwater* pump switch on main distribution panel (under companion lounge seating) to start pump.
- Open all faucets, sprayers, and wash-down connections.
- Run system until tank is completely empty.
- Press *Freshwater* pump switch again to stop pump.
- Add a non-toxic antifreeze to freshwater tank per manufacturer's recommendations.
- Press *Freshwater* pump switch again to start pump.
- Run system until antifreeze is seen running out of all faucets, sprayers, and wash-down connections.
- Close all faucets, wash-down connections and sprayers.
- Press *Freshwater* pump switch again to stop pump.

If a water heater is a part of the system, isolate the tank by disconnecting the in and out hoses and connecting them together. Make sure that the tank contains a sufficient amount of non-toxic antifreeze to avoid freezing and causing damage. Do not run the water heater without water in the unit.

Freshwater System Disinfection

After initial installation of the freshwater system, component replacement, or long-term storage, it is vital that it be properly disinfected. To disinfect:

- Flush entire system thoroughly by allowing potable water to flow through it.
- Drain system completely.
- Fill entire system with a chlorine solution strength of at least 100 parts per million. Allow to stand for one hour
- Drain entire system.
- Flush system thoroughly with potable water.
- Fill with potable water.

Head System

- Pump out holding tank at an approved facility.
- Add fresh water to bowl and flush several times while holding tank is being pumped.
- Use cleaning/sanitizing crystals or liquid, following manufacturer's recommendations, and let soak for a few minutes.
- Add fresh water and flush several times while pumping out holding tank again.
- Add antifreeze and flush/fill entire system.

Air Conditioning (A/C) System

Each A/C unit has a reusable air filter on the front of the unit that should be removed and cleaned periodically to assure clean air circulation and reduce wear on the unit. frequently inspect and keep clean the A/C's intake seacock strainer, located in the aft mechanical access hatch.

Electrical System

- Check all connections and tighten if necessary.
- Spray connections with an anti-corrosion spray.

Batteries

NOTICE

Follow battery manufacturer recommendations regarding long term battery storage.

Engine and house electrical systems are reliant on a good source of power. The house source of power typically comes from a battery bank comprised of two

or three batteries in parallel. The charging source for the batteries while away from the dock is the engines; or if equipped a generator. And when the generator is on, the battery chargers. Keep in mind the following battery recommendations.

Mixing Fresh/New and Used/Dead Batteries

The fresh battery will deliver current into a dead battery which has high resistance. This results in excessive heat in the used/dead battery, which can cause further damage, leakage, or rupture. A used battery will drain energy from the new one, reducing the total amount of battery power available.

Mixing Battery Types

Different battery types are designed for different purposes. Mixing an AGM battery with a lead-acid battery will not improve performance and instead may result in reduced performance, damaged equipment, or battery leakage or rupture.

Mixing Battery Brands

NOTICE

Remove battery from boat and store in a cool, dry location. Periodically check the battery during long term storage.

Different battery brands may not have the same specifications like marine cranking amps (MCA) or cold cranking amps (CCA). This results in excessive heat, which may cause damage, leakage or battery rupture. Use the same type of batteries throughout the boat.

Long-term Battery Storage

- Disconnect battery cables (negative first).
- Remove battery from boat.
- Clean terminal ends of cables and battery terminals with a solution of baking soda and water. Rinse thoroughly with clean water.
- Apply a coat of dielectric grease on terminal ends of cables and battery terminals.
- Store battery in a cool, dry area.
- Use a trickle charger to keep battery charged or charge battery every 30-60 days.

Drainage

It is important to raise the bow of the boat enough to allow for proper drainage of water from the deck and bilge area. Make sure all the drainage fittings are clear and free of debris and plugs are removed. Store the engine in an upright position to promote adequate drainage of water.

Avoid Loss

Remove any valuables or anything that can be easily removed from the boat such as electronics, lines, PFDs, fenders, cushions, etc., and store at home.

Cover

When covering this vessel it is best to use a frame of either aluminum or wood to keep the cover up. This allows air to circulate and discourages water from pooling on the cover. Vents along the entire length of the cover will allow condensation to escape. Placing a series of foam pads between the hull and cover will also aid in air circulation and reduce condensation. To help keep this vessel dry and mildew free, consider placing commercial odor and moisture absorbing products under the cover.

NOTICE

Do not use a bimini top in lieu of a cover. Damage and aging will occur without protection.

Trailer Storage

Repeatedly immersing the trailer in water during boat launching can cause a variety of problems. Water seeping into the wheel hubs will cause the grease to emulsify and prematurely corrode the bearings. Check with the trailer manufacturer for scheduled maintenance.

REFER TO THE OWNER'S PACKET FOR COMPLETE INSTRUCTIONS AND WARRANTY INFORMATION.

Environment

Antifreeze and other winterizing fluids can be toxic to aquatic life. Improper disposal of, or spillage of antifreeze and/or any winterization fluids can cause environmental problems when allowed to empty into waterways or on the ground. Furthermore, it is illegal, and at the minimum, punishable by fines. Used antifreeze or any winterization fluids, should not be disposed of into sanitary sewers or publicly-owned treatment plants. Direct any questions regarding recycling antifreeze or other toxic fluids to your state's EPA office.

Reinforcement Locations

This vessel has been manufactured with reinforcement in various locations throughout the deck. In the event you wish to add equipment that requires penetrating the deck with fasteners, Figure 5.11.1 illustrates the size, location, and type of the reinforcement available. The table below provides a description of the material and recommended fasteners to secure added equipment.

Reinforcement	Construction	Equipment weight	Fastener Type*
Plywood	Standard boat-building material	Light	Self-tapping screws
Trevira	Thick spunbound-polyester fabric	Light	Sheet Metal screws
Sparalloy	High-density plastic	Medium	Self-tapping screws
Phenolic	Reinforced-composite board	Heavy	Drill & Tap

* Drill and countersink a pilot hole to prevent damage to the gelcoat surface.

Reinforcement Locations

Figure 5.11.1

CAUTION

Do not attempt to secure equipment in any location other than those illustrated.

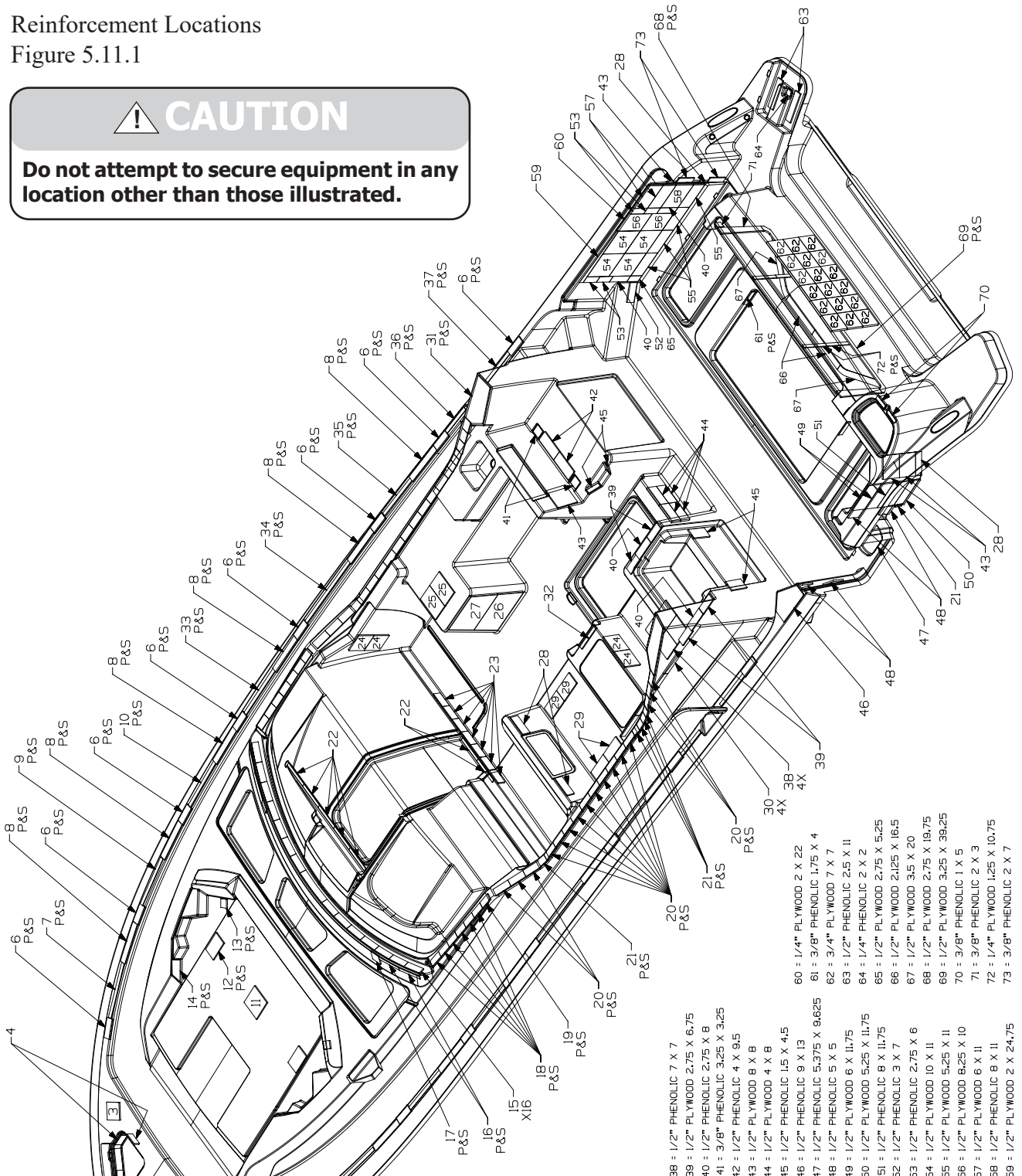

NOTE: P&S = port and starboard

- 1 = 1/2" PHENOLIC 9.5 X 20.5
- 2 = 1/2" PHENOLIC 18.75 X 19.3/75
- 3 = 1/2" PHENOLIC 6 X 6
- 4 = 1/2" PLYWOOD 2.75 X 4.5
- 5 = 1/2" PLYWOOD 2.75 X 7
- 6 = 1/2" PHENOLIC 2.75 X 7
- 7 = 1/4" PLYWOOD 1.25 X 20
- 8 = 1/2" PLYWOOD 1.25 X 15
- 9 = 1/4" PLYWOOD 1.25 X 19
- 10 = 1/4" PLYWOOD 1.25 X 19.5
- 11 = 1/2" PHENOLIC 8 X 8
- 12 = 1/2" PHENOLIC 5 X 8
- 13 = 1/2" PHENOLIC 3 X 3
- 14 = 1/2" PHENOLIC 3.5 X 7.3/75
- 15 = 1/2" PHENOLIC 2.25 X 7
- 16 = 1/4" PLYWOOD 1.25 X 9.5
- 17 = 3/8" PLYWOOD 4 X 4
- 18 = 1/2" PHENOLIC 2.5 X 5
- 19 = 1/4" PHENOLIC 2.5 X 4.5
- 20 = 1/2" PHENOLIC 3 X 6
- 21 = 1/2" PHENOLIC 3 X 3
- 22 = 1/2" PLYWOOD 1 X 10
- 23 = 1/2" PLYWOOD 3 X 6
- 24 = 1/2" PLYWOOD 7 X 7
- 25 = 1/2" PHENOLIC 6.5 X 9.75
- 26 = 3/4" PLYWOOD 11 X 18
- 27 = 3/4" PLYWOOD 11.75 X 18
- 28 = 1/2" PHENOLIC 3 X 8
- 29 = 1/2" PLYWOOD 5 X 8.5
- 30 = 1/2" PHENOLIC 2 X 10
- 31 = 1/2" PHENOLIC 7.5 X 24
- 32 = 1/2" PHENOLIC 1.75 X 10
- 33 = 1/4" PLYWOOD 1.25 X 20.5
- 34 = 1/4" PLYWOOD 1.25 X 28.5
- 35 = 1/4" PLYWOOD 1.25 X 17
- 36 = 1/4" PLYWOOD 1.25 X 11.25
- 37 = 1/4" PLYWOOD 1.25 X 14.5

- 38 = 1/2" PHENOLIC 7 X 7
- 39 = 1/2" PLYWOOD 2.75 X 6.75
- 40 = 1/2" PHENOLIC 2.75 X 8
- 41 = 3/8" PHENOLIC 3.25 X 3.25
- 42 = 1/2" PHENOLIC 4 X 9.5
- 43 = 1/2" PLYWOOD 8 X 8
- 44 = 1/2" PLYWOOD 4 X 8
- 45 = 1/2" PHENOLIC 1.5 X 4.5
- 46 = 1/2" PHENOLIC 9 X 13
- 47 = 1/2" PHENOLIC 5.375 X 9.625
- 48 = 1/2" PHENOLIC 5 X 5
- 49 = 1/2" PLYWOOD 6 X 11.75
- 50 = 1/2" PLYWOOD 5.25 X 11.75
- 51 = 1/2" PHENOLIC 8 X 11.75
- 52 = 1/2" PHENOLIC 3 X 7
- 53 = 1/2" PHENOLIC 2.75 X 6
- 54 = 1/2" PLYWOOD 10 X 11
- 55 = 1/2" PLYWOOD 5.25 X 11
- 56 = 1/2" PLYWOOD 8.25 X 10
- 57 = 1/2" PLYWOOD 6 X 11
- 58 = 1/2" PHENOLIC 8 X 11
- 59 = 1/2" PLYWOOD 2 X 24.75
- 60 = 1/4" PLYWOOD 2 X 22
- 61 = 3/8" PHENOLIC 1.75 X 4
- 62 = 3/4" PLYWOOD 7 X 7
- 63 = 1/2" PHENOLIC 2.5 X 11
- 64 = 1/4" PHENOLIC 2 X 2
- 65 = 1/2" PLYWOOD 2.75 X 5.25
- 66 = 1/2" PLYWOOD 2.125 X 16.5
- 67 = 1/2" PLYWOOD 3.5 X 20
- 68 = 1/2" PLYWOOD 2.75 X 19.75
- 69 = 1/2" PLYWOOD 3.25 X 39.25
- 70 = 3/8" PHENOLIC 1 X 5
- 71 = 3/8" PHENOLIC 2 X 3
- 72 = 1/4" PLYWOOD 1.25 X 10.75
- 73 = 3/8" PHENOLIC 2 X 7

THIS PAGE INTENTIONALLY LEFT BLANK