

230 Outrage

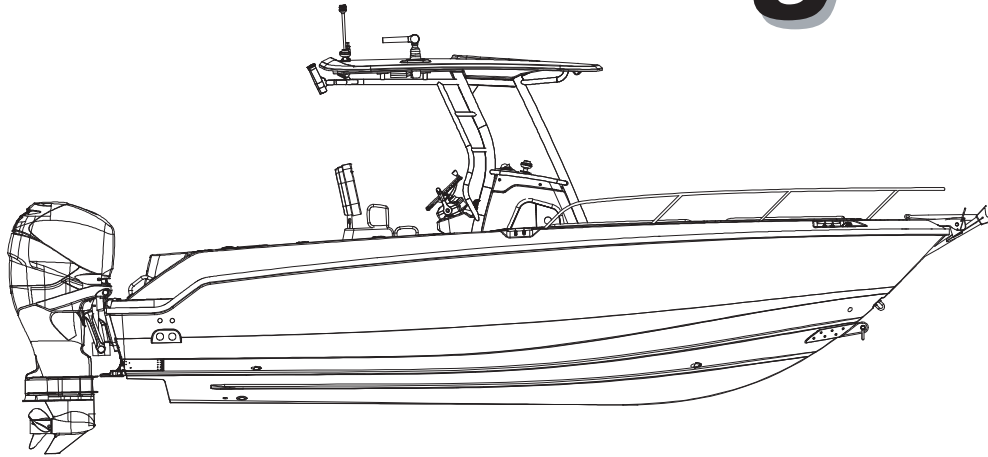

“The mission of Boston Whaler® is to provide consumers with the safest, highest quality, most durable boats in the world”

 **WARNING**

Operating, servicing and maintaining a recreational marine vessel can expose you to chemicals including engine exhaust, carbon monoxide, phthalates, and lead, which are known to the State of California to cause cancer and birth defects or other reproductive harm. To minimize exposure, avoid breathing exhaust, service your vessel in a well-ventilated area and wear gloves or wash your hands frequently when servicing this vessel. For more information go to www.P65warnings.ca.gov/marine.



THE UNSINKABLE LEGEND™

Welcome to the Boston Whaler family! Congratulations on your purchase of a Boston Whaler boat.

For over 50 years now, Boston Whaler has been represented by a select group of the best dealers in the boating industry. Boston Whaler depends on this extremely qualified network of dealers to provide you, our customer, with a truly exceptional boating experience.

Should you have any questions or concerns regarding your boat, please don't hesitate to contact your selling dealer. They will be more than happy to provide you with all the information and assistance that you require.

Information and assistance is also available at our corporate website, www.bostonwhaler.com. On our website you will find information on our entire lineup of Unsinkable Legends, as well as a collection of customer resources including parts diagrams, maintenance tips and frequently asked questions. In addition, you can sign up to receive future issues of Boston Whaler's lifestyle magazine, *Whaler*.

Since Boston Whaler's inception in 1958, we have been committed to providing customers with the safest, highest quality, most durable boats in the world. I am confident that you, as a Whaler owner, will also appreciate the quality and pride that is built into every Boston Whaler boat.

From all of us here at Whaler, thank you for purchasing one of our boats. May it bring you many years of boating enjoyment.

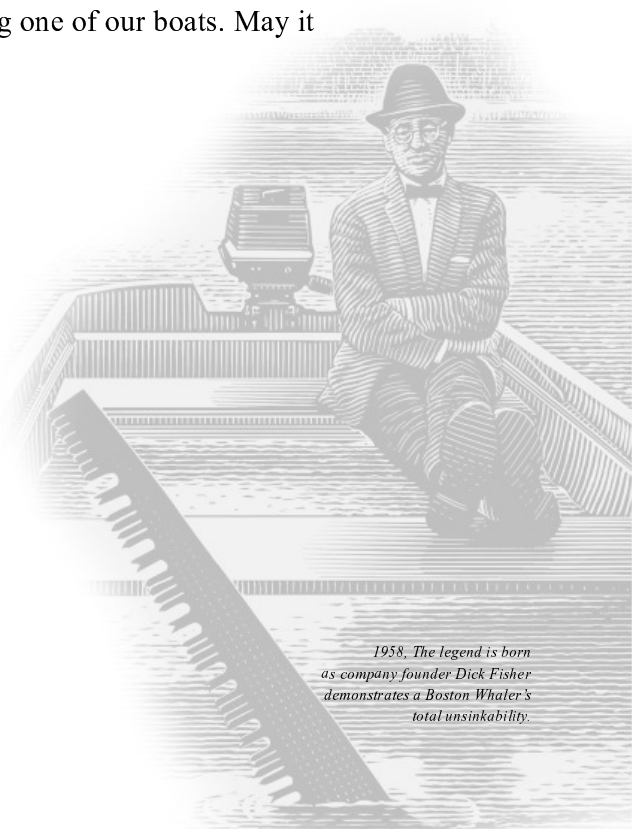

*1958, The legend is born
as company founder Dick Fisher
demonstrates a Boston Whaler's
total unsinkability.*

HISTORY

In 1958, company founder Richard T. Fisher introduced the first Boston Whaler® boat in Braintree, Massachusetts. It featured two significant innovations: first, its twin sponson hull design produced superior stability and a remarkably dry ride; second, its unique foam core construction made the boat not only durable, but unsinkable as well.

Fisher took every opportunity to illustrate the unique characteristics of the Boston Whaler®. His most famous demonstration was captured in 1961, by *Life Magazine*. The series of photographs showed the boat underway, the boat being sawed in half and ultimately Fisher motoring away in the remaining half of the boat. And through the years many other demonstrations have proved the toughness and durability of the Boston Whaler hull. And though you may never cut your boat in half, this only goes to show one thing, people whose livelihood and lives depend on boats consistently choose Boston Whaler® because of their seaworthiness, dependability and the inherent safety of a hull that won't sink even if severely damaged.

Boston Whalers are built to last. For over 50 years Boston Whaler® has strived to make each model better, providing you with a safe and fun boating experience. That is the reason we offer a 10 year limited transferable warranty. It is also an excellent reason why you can trust the safety of your family and friends to a Boston Whaler®.

On September 26, 1996, Richard T. Fisher was posthumously inducted into the NMMA (National Marine Manufacturer's Association) Hall of Fame for accomplishments made in marine engineering and construction.

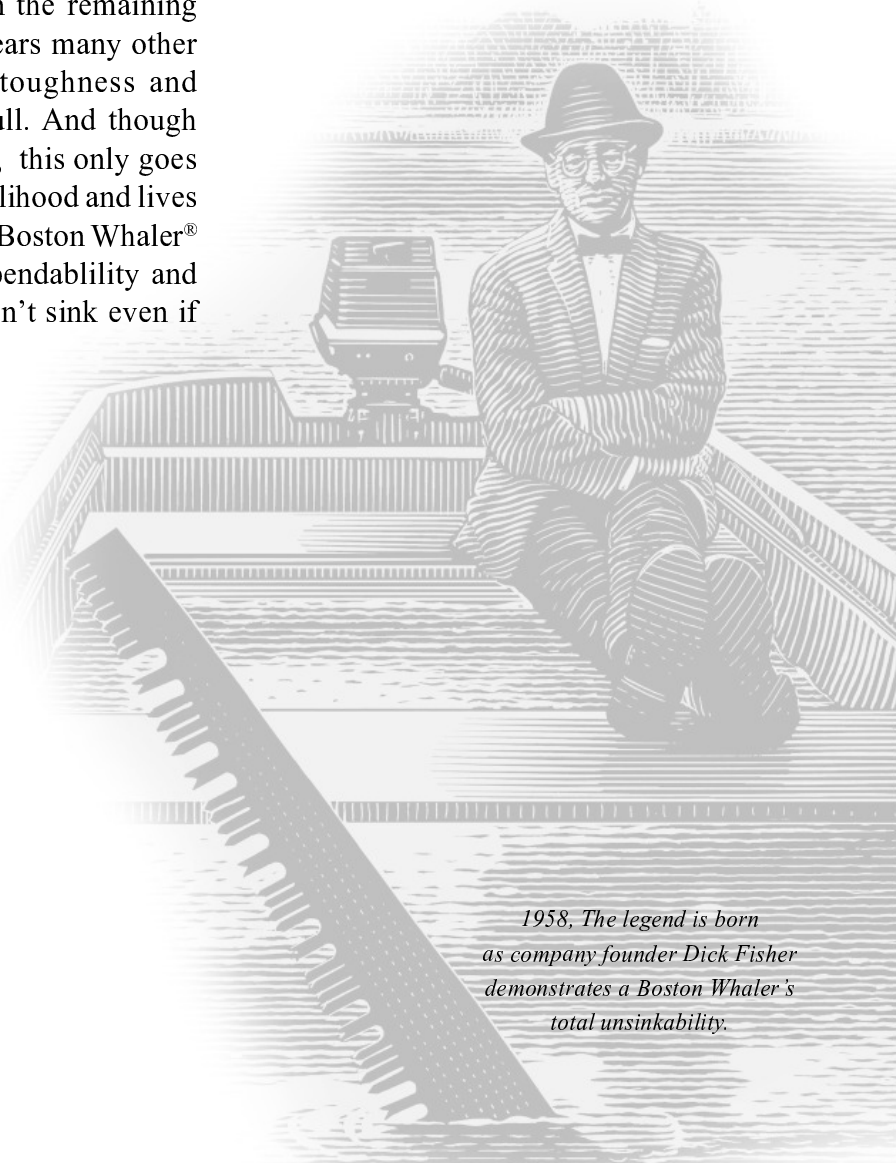

*1958, The legend is born
as company founder Dick Fisher
demonstrates a Boston Whaler's
total unsinkability.*

**PLEASE KEEP THIS OWNER'S MANUAL PACKET IN A SECURE PLACE, AND BE SURE
TO HAND IT OVER TO THE NEW OWNER IF YOU SELL THE BOAT.**

TABLE of CONTENTS

<p>Power Capacity 2-3</p> <p>Specifications & Dimensions 2-4</p> <p>Passenger Areas..... 2-5</p> <p>Recommended Passenger Locations 2-6</p> <p>Location Of Thru-Hull Fittings..... 2-7</p> <p>Features 2-8</p> <p>Console Features..... 2-9</p> <p>Helm Switch Panel..... 2-10</p> <p>Bilge Layout..... 2-10</p> <p>Bow Features..... 2-11</p> <p>Cockpit/Transom Features..... 2-11</p> <p>Transom Features..... 2-12</p> <p>Console Features (Interior) 2-13</p> <p>Leaning Post Features..... 2-14</p> <p>Hardtop Features 2-15</p> <p>Seating..... 2-16</p> <p>Smartcraft™ VesselView..... 2-16</p> <p style="padding-left: 20px;">System Calibration (First Time Use) 2-17</p> <p>Smartcraft™ VesselView MOBILE 2-17</p> <p>Digital Throttle/Shift (DTS®)..... 2-17</p> <p style="padding-left: 20px;">Power Trim Operation 2-18</p> <p>Dual Engine Gear Shift/Throttle (Option). 2-19</p> <p style="padding-left: 20px;">Throttle Only 2-19</p> <p style="padding-left: 20px;">Power Trim Operation 2-19</p> <p>Navigation Lighting..... 2-19</p> <p style="padding-left: 20px;">Operating The navigation Lighting 2-20</p> <p>Trim Tabs..... 2-21</p> <p style="padding-left: 20px;">Operation..... 2-21</p> <p style="padding-left: 20px;">Maintenance 2-21</p> <p>Active trim (Option)..... 2-22</p> <p>Canvas (Option) 2-22</p> <p>Propeller..... 2-23</p> <p>Bow Tow Eye (Option)..... 2-24</p> <p style="padding-left: 20px;">Towing A Disabled Boat..... 2-24</p> <p>Docking, Lifting and Trailering 2-25</p> <p style="padding-left: 20px;">Docking 2-25</p> <p style="padding-left: 20px;">Lifting 2-25</p> <p>Trailer (Option) 2-26</p> <p>Trailer Safety..... 2-26</p> <p>Trailer the Engine..... 2-27</p> <p>Section 3 • Systems & Components Overview & Operation</p> <p>Bilge Pump 3-1</p> <p style="padding-left: 20px;">Operation..... 3-1</p> <p style="padding-left: 20px;">Maintenance 3-1</p>	<p>Fuel & Oil Spillage 3-1</p> <p>Power Steering..... 3-2</p> <p style="padding-left: 20px;">Filling & Maintenance..... 3-2</p> <p>Fuel System 3-2</p> <p style="padding-left: 20px;">Fuel Tank..... 3-3</p> <p style="padding-left: 20px;">Fuel Vent 3-4</p> <p style="padding-left: 20px;">Filling the Tank..... 3-4</p> <p style="padding-left: 20px;">Fuel Distribution System 3-4</p> <p>Static Electricity and the Fuel System..... 3-4</p> <p style="padding-left: 20px;">Ethanol Blended Fuel 3-5</p> <p style="padding-left: 40px;">Filling The Tank 3-5</p> <p style="padding-left: 40px;">Phase Separation 3-6</p> <p style="padding-left: 40px;">Additives..... 3-6</p> <p style="padding-left: 40px;">Fuel Filters 3-6</p> <p style="padding-left: 40px;">Fuel/Water Separators 3-6</p> <p style="padding-left: 40px;">Maintenance..... 3-6</p> <p style="padding-left: 40px;">Storage 3-6</p> <p>Starting the Engine(s)..... 3-7</p> <p style="padding-left: 20px;">Prior To Starting 3-7</p> <p style="padding-left: 20px;">Ignition Key Starting 3-7</p> <p style="padding-left: 20px;">DTS Stop/Start Button Starting 3-7</p> <p>Stopping the Engines..... 3-7</p> <p>Fresh Water System (Option) 3-8</p> <p>Raw Water System 3-9</p> <p style="padding-left: 20px;">Operation..... 3-9</p> <p style="padding-left: 20px;">Maintenance 3-9</p> <p>Livewell 3-9</p> <p style="padding-left: 20px;">Operation..... 3-10</p> <p>Deluxe Leaning Post Livewell (Option) 3-10</p> <p style="padding-left: 20px;">Operation..... 3-10</p> <p style="padding-left: 20px;">Maintenance 3-11</p> <p>Head System 3-11</p> <p style="padding-left: 20px;">Portable Head w/Pump-Out & Overboard Discharge(Option)..... 3-11</p> <p style="padding-left: 20px;">Environmental Consideration 3-12</p> <p>Dockside Pumpout & Overboard</p> <p style="padding-left: 20px;">Discharge (Option) 3-12</p> <p style="padding-left: 20px;">Dockside Pumpout 3-12</p> <p style="padding-left: 40px;">To Lock The Discharge Seacock..... 3-13</p> <p style="padding-left: 20px;">Maintenance 3-13</p> <p>Entertainment System (Option) 3-14</p> <p style="padding-left: 20px;">Operating Your Stereo Using Your MP3 Player or USB Device (Option) 3-14</p> <p>Helm Bench Seat..... 3-15</p> <p style="padding-left: 20px;">To Lower The Utility Shelf 3-15</p> <p style="padding-left: 20px;">To Lower The Reverse Facing Seat..... 3-15</p> <p>Bow In-Floor Storage/Gutter Drain 3-15</p> <p>Ski Pylon (Option) 3-16</p> <p>Recreational Safety..... 3-16</p>
--	--

TABLE of CONTENTS

Bow Filler (Option)	3-16	Hull Blistering	5-2
Bow Table (Option)	3-16	Prevention	5-2
Retractable Swim Ladder	3-17	Bottom Painting	5-2
Anchor Windlass (Option)	3-17	Zinc Anodes	5-3
Operating The Windlass From		Bottom Painting a Bare Hull.....	5-3
The Helm.....	3-17	Bottom Painting a Pre-Painted Hull.....	5-3
Lowering The Anchor.....	3-17	Rubrail care	5-4
Raising The Anchor	3-17	Cleaning Fiberglass & Non-Skid	5-4
Operating The Windlass With Remote.....	3-18	Stainless Steel Care	5-4
Remote Operation.....	3-18	Seats (Mechanical Parts).....	5-5
Operating The Windlass Manually	3-19	Aluminum Care	5-5
Anchoring	3-20	Cushions.....	5-5
Considerations.....	3-20	To Clean Your Cushions.....	5-5
Lowering the Anchor.....	3-20	Cleaning Your Instrument Gauges	5-6
Setting the Anchor.....	3-21	Canvas Care and Maintenance.....	5-6
Weighing the Anchor	3-21	Maintaining a Good Appearance.....	5-6
		On a Regular Basis.....	5-6
		Cleaning stubborn Stains.....	5-7
		Maintaining Zippers and Hardware.....	5-7
		Cleaning Acrylic Windscreen.....	5-7
		Long term Storage & Winterization	5-8
		Engine	5-8
		Fuel System	5-8
		Electrical System	5-9
		Battery	5-9
		Deck.....	5-9
		Drainage.....	5-9
		Avoid Loss	5-9
		Cover.....	5-9
		Trailer Storage	5-9
		Environment	5-10
		Reinforcement Locations.....	5-10
		Reinforcement Location Diagram	5-11
		Maintenance Log	5-12

Section 4 • Electrical

DC Electrical System.....	4-1
Batteries.....	4-1
Battery Trays.....	4-1
Battery Trays (Dual Engine Option)	4-1
Battery Care.....	4-1
Battery Switches.....	4-2
House Main Breaker	4-2
12 Volt Accessory Receptacle	4-2
Component Breaker Panel (Single Engine). ..	4-3
Component Breaker Panel (Dual Engine)... ..	4-4
Fuse Blocks.....	4-5
Voltage Sensitive Relays (VSR)	4-5
Rigging.....	4-6
Electrical Schematics	4-7
Wiring Identification Chart	4-7

Section 5 • Care & Maintenance

Routine Care & Maintenance	5-1
Hull	5-1
Waxing the Gel Coat Surfaces	5-1
Hull Maintenance.....	5-2

Attachments

Commissioning Checklist

PREFACE

This Owner's Manual has been written to provide specific information about your boat and it should be read carefully. Keep this booklet with the Manuals in the Owner's Manual Packet. The Owner's Manual Packet has been compiled to help you operate your boat with safety and pleasure. It contains details of the boat, the equipment supplied or fitted, its systems and information on its operation and maintenance. Please familiarize yourself with the boat and its operation before using it. If this is your first boat, or you are changing to a type of boat you are not familiar with, for your own comfort and safety, please ensure that you obtain handling and operating experience before "assuming command" of your boat. Your Boston Whaler® dealer or local Yacht Club will be pleased to advise you of marine safety classes and safe boating classes in your area.

INFORMATION IN THIS PUBLICATION IS BASED ON THE LATEST PRODUCT SPECIFICATIONS AVAILABLE AT PRINTING. BOSTON WHALER® BOATS, INC. RESERVES THE RIGHT TO MAKE CHANGES AT ANY TIME WITHOUT NOTICE, IN THE COLORS, EQUIPMENT, SPECIFICATIONS, MATERIALS AND PRICES OF ALL MODELS, OR TO DISCONTINUE MODELS. SHOULD CHANGES OR MODIFICATIONS TO THE MODELS BE MADE BOSTON WHALER® IS NOT OBLIGATED TO MAKE SIMILAR CHANGES OR MODIFICATIONS TO MODELS SOLD PRIOR TO THE DATE OF SUCH CHANGES.

BOSTON WHALER® • A BRUNSWICK COMPANY
MRP #2357972

Printed in the U.S.A. © Boston Whaler, Inc. All rights reserved.

230 OUTRAGE
JULY, 2020

THE FOLLOWING ARE REGISTERED TRADEMARKS OF THE BRUNSWICK CORPORATION:

OUTRAGE, BOSTON WHALER®



Specifications and standard equipment are subject to change. Boston Whaler is not responsible for changes to parts or accessories manufactured by companies other than Boston Whaler. Active Deck Suspension System, Boston Whaler, Whaler, the Boston Whaler logo, Conquest, Dauntless, Montauk, and Outrage are registered trademarks of Boston Whaler, Incorporated. Accutrack, Unibond, The Unsinkable Legend, Ventura, and Whaleboard are trademarks of Boston Whaler, Incorporated. Mercury is a registered trademark of Mercury Marine, and SmartCraft and Verado are trademarks of Mercury Marine. Trademarks of others are the property of their respective owners. All Mercury engine information provided by Mercury Marine. Information contained within this publication is believed to be correct at the time of printing.

BOSTON WHALER LIMITED MANUFACTURER WARRANTY (US AND CANADA)

Boston Whaler, Inc. ("Boston Whaler") provides the following Limited Manufacturer Warranty to the original retail owner of its 2021 model year boats, if purchased from an authorized Boston Whaler Dealer and operated under normal, non-commercial use ("Boat"), subject to the remedies, exclusions, and limitations set out below.

- Ten-Year Structural Hull Limited Warranty:** Any Structural Hull Defect in material or workmanship which is reported within ten (10) years from the date of sale to the original retail owner will be repaired or replaced at Boston Whaler's sole discretion. The "Hull" shall mean the single fiberglass molded shell and integral structural components. A Structural Hull Defect shall mean a substantial defect in the Boat's Hull which causes the boat to be unfit or unsafe for general use as a pleasure craft under normal operating conditions.
- Three-Year Limited Warranty on Components Manufactured or Installed By Boston Whaler:** *(not applicable to 13 Super Sport or 16 Super Sport models):* Boston Whaler will repair or replace, at its sole discretion, any components manufactured or installed by Boston Whaler that are defective in factory materials and/or workmanship, which are reported within three (3) years from the date of sale to the original retail owner, and are not addressed in the specific warranties listed in paragraphs 1 or 4 or set out in the Exclusions paragraph below.
- One-Year Limited Warranty on Accessory Components for the 13 Super Sport and 16 Super Sport Models:** Boston Whaler provides the following Limited Warranty to the original retail owner of any factory-authorized accessory for the 2021 model year 13 Super Sport and 16 Super Sport, if purchased from an authorized Boston Whaler Dealer, authorized Boston Whaler website or any Boston Whaler affiliate and utilized under normal, non-commercial use ("Accessory"), subject to the remedies, exclusions, and limitations set out below. Boston Whaler will repair or replace, at its sole discretion, any Accessory that is defective in material or workmanship, which is reported within one (1) year from the date of sale to the original retail owner. Boston Whaler is not responsible for any defect and/or damage to the Accessory and/or the boat caused by improper installation, whether performed by the retail owner, dealer or any other third party.
- One-Year Limited Warranty on Upholstered Items, Canvas, Teak, and Powder Coating:** Boston Whaler will repair or replace, at its sole discretion, any upholstered items, canvas, teak, and powder coating manufactured or installed by Boston Whaler that are defective in factory materials and/or workmanship and are reported within one (1) year from the date of sale to the original retail owner.
- Limited Engine Warranty:** Retail owners will be entitled to the limited engine warranty as provided in the warranty manual from the engine manufacturer that was delivered to the retail owner with his or her Boston Whaler Boat.

EXCLUSIONS

This Limited Manufacturer Warranty does not apply to any boat which has been salvaged or declared a total loss or constructive total loss for any reason not covered in this limited warranty. This Warranty also does not apply to the following items:

- 1) Expenses for hauling out, transportation to and from the dealer or the Boston Whaler factory for warranty service.
- 2) Equipment or accessories which are not installed by Boston Whaler or which carry their own individual warranties, including but not limited to engines, engine components, batteries, propellers, controls, steering mechanisms, and electronics.
- 3) Damage, deterioration, discoloration or mold of cushions or cosmetic surface finishes, including scratches, gouges, chips, chalking, blistering, cracking, crazing, fading or oxidation of gel coat, stress lines, plated or painted metal and stainless steel finishes, plastics or acrylic materials, or anti-fouling bottom paint.
- 4) Windshield breakage and leakage.
- 5) Any Boston Whaler Boat initially sold at retail by a party other than an authorized Boston Whaler dealer.
- 6) Damage resulting from abuse, misuse, improper rigging and installation by an owner or any other person or entity not being an authorized dealer, accidents, overloading or powering in excess of the recommended maximum horsepower.
- 7) Failure of the owner to use, maintain, or store the boat as specified in the Boston Whaler owner's manual; and any other failure to provide reasonable care and maintenance. Normal wear and tear maintenance items are excluded from warranty coverage including but not limited to filters, bulbs, batteries, bungees, wiper blades, anchor rope, trailer finishes, tires, brakes, bearings and lights.
- 8) Any Boston Whaler Boat which has been altered or modified from Boston Whaler factory specifications, including penetration of the hull by anyone other than Boston Whaler factory personnel or Boston Whaler authorized dealer service personnel following factory specified procedures.

- 9) Damages resulting from use of improper trailer, improperly placed supporting bunks or slings, incorrect bunks placement and improper boat lift or sling.
- 10) Any Boston Whaler Boat used for commercial purposes, which includes, but is not limited to, any for-profit or other revenue-generating uses.
- 11) Any representation or implication relating to speed, range, fuel consumption or estimated performance characteristics.
- 12) Any failure or defect caused by an act of nature resulting in damage, cost, or expense;
- 13) Any failure or defect arising from a previous repair made by a non-authorized service provider.
- 14) Any item exceeding the expressed coverage limits specified in any Boston Whaler Limited Manufacturer Warranty.
- 15) Failure of the owner to use, maintain, or store an Accessory in reasonable fashion; and any other failure to provide reasonable care and maintenance.
- 16) Any accessory which has been altered or modified from Boston Whaler factory specifications.
- 17) Any accessory not purchased from an authorized Boston Whaler Dealer, authorized Boston Whaler website, or authorized Boston Whaler affiliate. For a list of Boston Whaler's affiliates, please refer to www.brunswick.com.
- 18) Any accessory used for commercial purposes, which includes but is not limited to, any for-profit or other revenue generating uses.
- 19) Any defect or repair requiring redesign of the Boat, except pursuant to the recall provisions of the United States Federal Boat Safety Act of 1971 or the recall laws of any other foreign jurisdiction.

SOLE REMEDY

THE REMEDY OF REPAIR OR REPLACEMENT OF PARTS OR MATERIALS THAT ARE FOUND TO BE DEFECTIVE IN FACTORY MATERIALS OR WORKMANSHIP COVERED BY THIS LIMITED MANUFACTURER WARRANTY SHALL CONSTITUTE THE OWNER'S SOLE AND EXCLUSIVE REMEDY AGAINST BOSTON WHALER FOR ANY CLAIMS WHATSOEVER OF ECONOMIC LOSS RESULTING FROM PRODUCT FAILURE. In keeping with environmental policies and practices, Boston Whaler reserves the right to utilize reconditioned, refurbished, repaired or remanufactured products or parts in the warranty repair or replacement process. Such products and parts will be comparable in function and performance to an original product or part and warranted for the remainder of the original warranty period. In no event shall any repair or replacement under this Limited Manufacturer Warranty exceed the fair market value of the product as of the date of the owner's claim. Acceptance of any product returned or any refund provided by Boston Whaler shall not be deemed an admission that the product is defective. Products that are replaced become the property of Boston Whaler.

OTHER LIMITATIONS

EXCEPT AS SET FORTH HEREIN, THERE ARE NO OTHER WARRANTIES EITHER EXPRESS OR IMPLIED PROVIDED BY BOSTON WHALER ON THIS BOAT. ALL OTHER WARRANTIES, EXPRESS OR IMPLIED, INCLUDING IMPLIED WARRANTIES OF FITNESS AND MERCHANTABILITY, ARE EXPRESSLY EXCLUDED. BOSTON WHALER FURTHER DISCLAIMS ANY LIABILITY FOR ECONOMIC LOSS ARISING FROM CLAIMS OF PRODUCT FAILURE, NEGLIGENCE, DEFECTIVE DESIGN, MANUFACTURING DEFECT, FAILURE TO WARN AND/OR INSTRUCT, LACK OF SEAWORTHINESS, AND ANY OTHER THEORY OF LIABILITY NOT EXPRESSLY COVERED UNDER THE TERMS OF THIS LIMITED MANUFACTURER WARRANTY.

ANY IMPLIED WARRANTY OF MERCHANTABILITY OR FITNESS FOR A PARTICULAR PURPOSE IS DISCLAIMED. TO THE EXTENT THE IMPLIED WARRANTY CANNOT BE DISCLAIMED, IT IS LIMITED TO THE SHORTER OF ONE YEAR FROM THE DATE OF DELIVERY TO THE FIRST RETAIL OWNER OR THE DURATION OF THE RESPECTIVE EXPRESS LIMITED WARRANTIES STATED HEREIN. TO THE EXTENT ALLOWED BY LAW, NEITHER BOSTON WHALER, NOR THE SELLING DEALER, SHALL HAVE ANY RESPONSIBILITY FOR LOSS OF THE BOAT, LOSS OF TIME, INCONVENIENCE, COMMERCIAL LOSS OR CONSEQUENTIAL DAMAGES. SOME STATES DO NOT ALLOW LIMITATIONS ON HOW LONG AN IMPLIED WARRANTY LASTS, SO THE ABOVE LIMITATION MAY NOT BE APPLICABLE. SOME STATES DO NOT ALLOW THE EXCLUSION OR LIMITATION OF INCIDENTAL OR CONSEQUENTIAL DAMAGES, SO THE ABOVE LIMITATIONS OR EXCLUSIONS MAY NOT BE APPLICABLE. THIS WARRANTY GIVES THE OWNER SPECIFIC LEGAL RIGHTS, AND THE OWNER MAY ALSO HAVE OTHER RIGHTS WHICH VARY FROM STATE TO STATE OR COUNTRY TO COUNTRY.

STATUTE OF LIMITATIONS

Any action for rescission or revocation against Boston Whaler shall be barred unless it is commenced within one (1) year from the date of accrual of such cause of action. This provision does not grant any consumer a right of rescission or revocation against Boston Whaler, where such right does not otherwise exist under applicable law. Some states may not allow the applicable statute of limitations for rescission or revocation to be reduced, so this provision may not apply to each retail owner.

OWNER'S OBLIGATIONS

To initiate a warranty claim, it is the responsibility of the owner to contact an authorized Boston Whaler dealer immediately after discovery of any defect, describe the nature of the problem, and provide a hull serial number, date of purchase, and name of selling dealer. The authorized dealer will notify Boston Whaler, who is solely responsible for determining and authorizing in writing the remedial action(s) to be performed at either an authorized Boston Whaler dealership chosen by Boston Whaler or at the Boston Whaler factory. The owner should notify Boston Whaler of any boat being repaired by an authorized Boston Whaler dealer which has been at the dealership for fifteen (15) days, or of any claimed defect which was not corrected after one repair attempt. The owner must provide Boston Whaler with a reasonable opportunity to repair, and reasonable access to the Boston Whaler Boat for warranty service and the owner shall pay for all related transportation charges and/or travel time. If the owner cannot deliver the product to such a dealer, written notice must be given to Boston Whaler. Boston Whaler will then arrange for the inspection and any covered repair and the owner shall pay for all related transportation charges and/or travel time. Our privacy policies are available at www.bostonwhaler.com.

ASSIGNMENT OF COMPONENT WARRANTIES

Except as expressly set out herein, all warranties provided by the manufacturers and distributors of components, equipment, and parts on the boat (collectively "Component Manufacturers") are hereby assigned to the owner to the extent permitted by the Component Manufacturers, as the owner's sole and exclusive remedy with respect to such items.

REGISTRATION & WARRANTY TRANSFER POLICY

The limited warranty coverage is activated by the authorized selling dealer registering the sale of a new Boat with Boston Whaler. The Ten-Year, Three-Year, and One-Year limited warranties are transferable to a subsequent owner, except the one-year Accessory warranty which is not transferrable and this Limited Manufacturer Warranty will not transfer to any new owner of a boat which has been salvaged and resold, or resold after a declaration of a total loss or a constructive total loss, i.e., the cost of repair exceeds the value of the boat. The new owner must fill out and submit the online Boston Whaler warranty transfer form, accessible from www.bostonwhaler.com. A copy of the bill of sale will be required to submit with the form. The warranty transfer must be completed within 30 days of purchase.

MODIFICATIONS & SEVERABILITY

The terms and conditions contained herein, as well as those of any documents prepared in conjunction with the sale of this vessel may not be modified, altered or waived by any action, inaction, or representations, whether oral or in writing, except upon the expressed, written authority of a management level employee of Boston Whaler. The invalidity or unenforceability of any one or more of the provisions herein shall not affect the validity and enforceability of the other provisions.

GOVERNING LAW AND VENUE

This Warranty shall be interpreted and construed according to and governed by the laws of the State of Tennessee, without regard to conflict of law principles. Venue for any and all disputes arising out of or related to this Warranty, including without limitation the interpretation, performance or breach of this Warranty, shall be solely and exclusively before the United States District Court for the Eastern District of the State of Tennessee. The parties consent to the in personam jurisdiction of said court for the purposes of any such litigation and waive, fully and completely, any right to dismiss and/or transfer any action pursuant to 28 U.S.C. Section 1404 or 1406 (or any successor statutes) or the doctrine of forum non conveniens. If the United States District Court does not have subject matter jurisdiction of said matter, then such matter shall be litigated solely and exclusively before the appropriate state court of competent jurisdiction located in Knox County, Tennessee, and the parties consent to the personal jurisdiction of such court for the purpose of such litigation.

SAFETY

It is your responsibility (as well as the responsibility of any other operator of this boat) to be familiar with and observe all local, state and federal laws, rules and regulations regarding boating, navigation and boating safety. You and any other operator of this boat should take a course in boating and boating safety before operation of this boat and should be completely familiar with all systems regarding safe operation of this boat. Personal flotation devices should be worn by each passenger in accordance with U.S. Coast Guard standards and state and federal law.

World Headquarters, 100 Whaler Way, Edgewater, FL 32141

Phone (386) 428-0057

Internet Address: www.bostonwhaler.com

BOSTON WHALER LIMITED MANUFACTURER WARRANTY

Outside the U.S. or Canada

Boston Whaler, Inc. ("Boston Whaler") provides the following Limited Manufacturer Warranty to the original retail owner of its 2021 model year boats, that if purchased from an authorized Boston Whaler dealer and operated under normal, non-commercial use, the authorized dealer will repair or replace, at its sole discretion, any defect in material or workmanship in the Boston Whaler Boat that is reported within the applicable Limited Manufacturer Warranty periods and within the scope as set out below.

Mandatory warranty rights, including a consumer's mandatory statutory rights, by law are not affected by this Limited Manufacturer Warranty and in particular not limited or excluded. These mandatory legal rights exist regardless of whether a warranty claim occurs or rights are asserted under this Limited Manufacturer Warranty.

SCOPE

This Limited Manufacturer Warranty applies only to Boston Whaler Boats purchased outside of the US and Canada, including the territory of the European Union and Australia, and to recreational use customers only (not commercial users). Commercial use, which voids the Limited Manufacturer Warranty, is defined as any use of the product which generates income, even if the product is only occasionally used for such purposes.

Routine maintenance outlined in the Operation and Maintenance Manual must be timely performed in order to maintain Limited Manufacturer Warranty coverage.

This Limited Manufacturer Warranty applies to the following items:

- 1. Ten-Year Structural Hull Limited Warranty:** Any Structural Hull Defect in material or workmanship which is reported within ten (10) years from the date of sale to the original retail owner will be repaired or replaced at Boston Whaler's sole discretion. The "Hull" shall mean the single fiberglass molded shell and integral structural components. A Structural Hull Defect shall mean a substantial defect in the Boat's Hull which causes the boat to be unfit or unsafe for general use as a pleasure craft under normal operating conditions
- 2. Three-Year Limited Warranty on Components Manufactured or Installed By Boston Whaler (not applicable to 13 Super Sport or 16 Super Sport models):** Boston Whaler will repair or replace, at its sole discretion, any components manufactured or installed by Boston Whaler that are defective in factory materials and/or workmanship, which are reported within three (3) years from the date of sale to the original retail owner, and are not addressed in the specific warranties listed in paragraphs 1 or 4 or set out in the Exclusions paragraph below.
- 3. One-Year Limited Warranty on Accessory Components for the 13 Super Sport and 16 Super Sport Models:** Boston Whaler provides the following Limited Warranty to the original retail owner of any factory-authorized accessory for the 2021 model year 13 Super Sport and 16 Super Sport, if purchased from an authorized Boston Whaler Dealer, authorized Boston Whaler website or any Boston Whaler affiliate and utilized under normal, non-commercial use ("Accessory"), subject to the remedies, exclusions, and limitations set out below. Boston Whaler will repair or replace, at its sole discretion, any Accessory that is defective in material or workmanship, which is reported within one (1) year from the date of sale to the original retail owner. Boston Whaler is not responsible for any defect and/or damage to the Accessory and/or the boat caused by improper installation, whether performed by the retail consumer, dealer or any other third party.
- 4. One-Year Limited Warranty on Upholstered Items, Canvas, Teak, and Powder Coating:** Boston Whaler will repair or replace, at its sole discretion, any upholstered items, canvas, teak, and powder coating manufactured or installed by Boston Whaler that are defective in factory materials and/or workmanship and are reported within one (1) year from the date of sale to the original retail owner.
- 5. Limited Engine Warranty:** Retail owners will be entitled to the limited engine warranty as provided in the warranty manual from the engine manufacturer that was delivered to the original retail owner with his or her Boston Whaler Boat.

ENVIRONMENTAL POLICIES

In keeping with environmental policies and practices, Boston Whaler reserves the right to utilize reconditioned, refurbished, repaired or remanufactured products or parts in the warranty repair or replacement process. Such products and parts will be comparable in function and performance to an original product or part and warranted for the remainder of the original warranty period.

EXCLUSIONS

This Limited Manufacturer Warranty does not apply to any boat which has been salvaged or declared a total loss or constructive total loss for any reason not covered in this limited warranty. This warranty also does not apply to the following items:

- 1) Expenses for hauling out, transportation to and from the dealer or the Boston Whaler factory for warranty service.
- 2) Equipment or accessories which are not installed by Boston Whaler or which carry their own individual warranties, including but not limited to engines, engine components, batteries, propellers, controls, steering mechanisms, and electronics.
- 3) Damage, deterioration, discoloration or mold of cushions or cosmetic surface finishes, including scratches, gouges, chips, chalking, blistering, cracking, crazing, fading or oxidation of gel coat, stress lines, plated or painted metal and stainless steel finishes, plastics or acrylic materials, or anti-fouling bottom paint.
- 4) Windshield breakage and leakage.
- 5) Any Boston Whaler Boat initially sold at retail by a party other than an authorized Boston Whaler dealer.
- 6) Damage resulting from abuse, misuse, improper rigging and installation by an owner or any other person or entity not being an authorized dealer, accidents, overloading or powering in excess of the recommended maximum horsepower.
- 7) Failure of the owner to use, maintain, or store the boat as specified in the Boston Whaler owner's manual; and any other failure to provide reasonable care and maintenance. Normal wear and tear maintenance items are excluded from warranty coverage including but not limited to filters, bulbs, batteries, bungees, wiper blades, anchor rope, trailer finishes, tires, brakes, bearings and lights.
- 8) Any Boston Whaler Boat which has been altered or modified from Boston Whaler factory specifications, including penetration of the hull by anyone other than Boston Whaler factory personnel or Boston Whaler authorized dealer service personnel following factory specified procedures.
- 9) Damage resulting from use of improper trailer, improperly placed supporting bunks or slings, incorrect bunks placement and improper boat lift or sling.
- 10) Any Boston Whaler Boat used for commercial purposes, which includes, but is not limited to, any for-profit or other revenue-generating uses.
- 11) Any representation or implication relating to speed, range, fuel consumption or estimated performance characteristics.
- 12) Any failure or defect caused by an act of nature resulting in damage, cost, or expense;
- 13) Any failure or defect arising from a previous repair made by a non-authorized service provider.
- 14) Any item exceeding the expressed coverage limits specified in any Boston Whaler Limited Manufacturer Warranty.
- 15) Failure of the owner to use, maintain, or store an Accessory in reasonable fashion; and any other failure to provide reasonable care and maintenance.
- 16) Any Accessory which has been altered or modified from Boston Whaler factory specifications.
- 17) Any Accessory not purchased from an authorized Boston Whaler Dealer, authorized Boston Whaler website, or authorized Boston Whaler affiliate. For a list of Boston Whaler's affiliates, please refer to www.brunswick.com.
- 18) Any Accessory used for commercial purposes, which includes but is not limited to, any for-profit or other revenue generating uses.
- 19) Any defect or repair requiring redesign of the Boat, except pursuant to the recall provisions of the United States Federal Boat Safety Act of 1971 or the recall laws of any other foreign jurisdiction.

ACCESS FOR SERVICE

The owner must provide Boston Whaler with a reasonable opportunity to repair, and reasonable access to the Boston Whaler Boat for warranty service. Warranty claims shall be made by delivering the Boston Whaler Boat for inspection to a Boston Whaler dealer authorized to service the product. If the owner cannot deliver the product to such a dealer, written notice must be given to Boston Whaler. Boston Whaler will then arrange for the inspection and any covered repair and the owner shall pay for all related transportation charges and/or travel time.

STATUTE OF LIMITATIONS

Without prejudice to your mandatory statutory rights, any action for rescission or revocation against Boston Whaler shall be barred unless it is commenced within one (1) year from the date of accrual of such cause of action, unless a longer period is prescribed by local law. This section shall not apply to Boston Whaler Boats purchased in Australia.

ASSIGNMENT OF COMPONENT WARRANTIES

Except as expressly set out herein, all warranties provided by the manufacturers and distributors of components, equipment, and parts on the boat (collectively "Component Manufacturers") are hereby assigned to the owner to the extent permitted by the Component Manufacturers, as the owner's sole and exclusive remedy with respect to such items.

OWNER'S OBLIGATIONS

To initiate a warranty claim, it is the responsibility of the owner to contact an authorized Boston Whaler dealer immediately after discovery of any defect, describe the nature of the problem, and provide a hull serial number, date of purchase, and name of selling dealer. The authorized dealer will notify Boston Whaler, who is solely responsible for determining and authorizing in writing the remedial action(s) to be performed at either an authorized Boston Whaler dealership chosen by Boston Whaler or at the Boston Whaler factory. The owner should notify Boston Whaler of any boat being repaired by an authorized Boston Whaler dealer which has been at the dealership for fifteen (15) days, or of any claimed defect which was not corrected after one repair attempt. Our privacy policies are available at www.bostonwhaler.com.

REGISTRATION & WARRANTY TRANSFER POLICY

The limited warranty coverage is activated by the authorized selling dealer registering the sale of a new Boat with Boston Whaler. The Ten-year, Three-year, and One-year Limited Warranties are transferable to a subsequent owner, except the One-year Accessory Warranty which is not transferrable, and this Limited Manufacturer Warranty will not transfer to any new owner of a boat which has been salvaged and resold, or resold after a declaration of a total loss or a constructive total loss, i.e., the cost of repair exceeds the value of the boat. The new owner must fill out and submit the online Boston Whaler warranty transfer form, accessible from www.bostonwhaler.com. A copy of the bill of sale will be required to submit with the form. The warranty transfer must be completed within 30 days of purchase.

MODIFICATIONS & SEVERABILITY

The terms and conditions contained herein, as well as those of any documents prepared in conjunction with the sale of this vessel may not be modified, altered or waived by any action, inaction, or representations, whether oral or in writing, except upon the expressed, written authority of a management level employee of Boston Whaler. The invalidity or unenforceability of any one or more of the provisions herein shall not affect the validity and enforceability of the other provisions.

SAFETY

It is your responsibility (as well as the responsibility of any other operator of this boat) to be familiar with and observe all local, state and federal laws, rules and regulations regarding boating, navigation and boating safety. You and any other operator of this boat should take a course in boating and boating safety before operation of this boat and should be completely familiar with all systems regarding safe operation of this boat. Personal flotation devices should be worn by each passenger in accordance with applicable standards and state and federal law.

THE FOLLOWING SECTION IS APPLICABLE TO AUSTRALIAN CONSUMERS ONLY

Boston Whaler Boats come with guarantees that cannot be excluded under the Australian Consumer Law. Retail owners are entitled to a replacement or refund for a major failure and compensation for any other reasonably foreseeable loss or damage. Retail owners are also entitled to have the goods repaired or replaced if the goods fail to be of acceptable quality and the failure does not amount to a major failure.

This Limited Manufacturer Warranty does not cover any expenses that retail owners may incur claiming the warranty.

The benefits to retail owners given by this Limited Manufacturer Warranty are in addition to other rights and remedies of the consumer under a law in relation to the goods or services to which the Limited Manufacturer Warranty relates.

World Headquarters, 100 Whaler Way, Edgewater, FL 32141

Phone 011 1 (386) 428-0057

Internet Address: www.bostonwhaler.com

**CALIFORNIA EVAPORATIVE EMISSIONS
CONTROL SYSTEM WARRANTY STATEMENT**

YOUR WARRANTY RIGHTS AND OBLIGATIONS:

The California Air Resources Board and Boston Whaler, Inc. (“Boston Whaler”) are pleased to explain the evaporative emission control system’s warranty on your 2021 MY spark-ignition marine watercraft (SIMW). In California, new spark-ignition marine watercraft must be designed, built, and equipped to meet the State’s stringent anti-smog standards. Boston Whaler must warrant the evaporative emission control system on your spark ignition marine watercraft for the period listed below provided there has been no abuse, neglect or improper maintenance of your spark-ignition marine watercraft.

Your evaporative emission control system may include parts such as: carburetors, fuel tanks, fuel lines, fuel caps, valves, canisters, filters, vapor hoses, clamps, connectors, and other associated components.

MANUFACTURER’S WARRANTY COVERAGE:

This evaporative emission control system is warranted for three years. If any evaporative emission-related part on your spark-ignition marine watercraft is defective, the part will be repaired or replaced by Boston Whaler.

OWNER’S WARRANTY RESPONSIBILITIES:

- As the spark ignition marine watercraft owner, you are responsible for performance of the required maintenance listed in your owner’s manual. Boston Whaler, Inc. recommends that you retain all receipts covering maintenance on your SIMW, but Boston Whaler cannot deny warranty solely for the lack of receipts.
- As the SIMW owner, you should however be aware that the Boston Whaler may deny you warranty coverage if your spark-ignition marine watercraft or a part has failed due to abuse, neglect, or improper maintenance or unapproved modifications.
- You are responsible for presenting your spark-ignition marine watercraft to a Boston Whaler distribution center or service center as soon as the problem exists. The warranty repairs should be completed in a reasonable amount of time, not to exceed 30 days. If you have a question regarding your warranty coverage, you should contact Boston Whaler at 877-294-5645.

SIMW EVAPORATIVE EMISSIONS WARRANTY PARTS:

Fuel tank	Grade Valves
Fuel feed hoses	Fuel Fill Deck Plate W/Cap and Pressure Relief Valve
Fuel Line Fittings	Hose Clamps on Fuel System Components
Fuel Demand Valves	Fuel Level Vent Valve

All other parts not listed that may affect the evaporative emissions control system

PRIVACY STATEMENT

Thank you for purchasing a boat or requesting information from Boston Whaler! This Privacy Statement is to inform you how we collect, use, disclose, and safeguard the personal information you provide to us through your purchases, requests for brochures, product registration cards, promotions, surveys, call centers, or other customer contacts. To see our full Privacy Policy and any updates, please visit www.bostonwhaler.com and select the Privacy Statement link.

“Personal information” may include your name, age, mailing address, residential phone number, or e-mail address. It may also include income ranges, marital status, product or lifestyle preferences, and information concerning dealer service.

How We Collect Personal Information: Our authorized dealer provided Boston Whaler or our company in the European Union with personal information collected at the time of your boat order/purchase with other product registration data and will continue to provide warranty and servicing information on your boat. We will send you customer satisfaction surveys which you may elect to return to provide us with information on your boat purchase and your servicing needs. Your personal information may be gathered by or shared with Boston Whaler’s marketing providers and affiliated companies, who have comparable levels of privacy protection, for the purposes described in this statement. Boston Whaler, your dealer, and our marketing providers collect personal information when your request information about our companies and from surveys, promotions, contests, correspondence, your e-mails, telephone inquiries, web forms, and other communications.

How We Use & Disclose Personal Information: Unless you advise us otherwise, Boston Whaler, our authorized dealers, affiliated companies, and our marketing providers may generally collect, use, disclose, hold, and file your personal information for the following purposes: (1) Providing goods, brochures, information, incentives, and/or services to you or on your behalf; (2) Fulfilling the terms of our limited warranty or other service obligation; (3) Facilitating recalls or service campaigns if necessary; (4) Reviewing goods and/or services provided to you in product, services, and marketing analyses; (5) Ensuring your satisfaction through surveys or other contacts; (6) Administration, billing, accounting, and collections; and protecting against fraud and error; and (7) Investigating a breach or a contravention of a law, complying with a subpoena, warrant, court order, or as required or otherwise permitted by law. **BOSTON WHALER WILL NOT SELL YOUR PERSONAL INFORMATION OR SUBJECT YOU TO TELEMARKETING OR UNSOLICITED E-MAIL.**

Safeguards: We use security safeguards appropriate to the sensitivity of personal information to protect it from loss or theft, as well as prohibiting unauthorized access, disclosure, copying, use or modification of your personal information. These safeguards include restricted access to offices and equipment, security clearances, the use of passwords and/or encryption, publishing our privacy policy to appropriate personnel with instructions to act in accordance with its principles, and contractual provisions with our marketing agents and authorized dealers to follow the principles of our privacy policy.

Access and Correction to Your Personal Information: Subject to the exceptions provided by applicable law, we will provide, upon written request, your specific personal information collected in a form which is generally understandable. Your Personal Information is held by us and for us by our marketing agency, AVALA, who has contractually agreed to protect your information according to our privacy policies at the following addresses: Boston Whaler Inc., 100 Whaler Way, Edgewater, FL 32141. Please direct corrections, withdrawal of consent for specific purpose, complaints or other inquiries regarding personal information to: Terry Domian, AVALA Marketing Group; 1078 Headquarters Park Drive, Fenton, MO, 63026; Phone: (636) 343-9988, Fax: (636) 326-3282, E-mail: terryd@MarketingAgencymarketing.com. You can withdraw consent for us to use your personal information at any time or provide corrections upon providing to us a 30-day notice, unless withdrawing consent would impede the performance of legal obligations. We are required by law to provide you with information for product recall and other product safety related purposes. The withdrawal of your consent may also adversely affect our ability to provide products and services to you and to maintain our relationship. Please note, notifying us will not result in withdrawing consent from your dealer, who should be contacted separately.

Obtaining Consent: If any supplementary disclosure is required, we will obtain your consent for disclosure to other persons or organizations and for other purposes than stated herein, unless otherwise permitted by law.

Thank you again for your business. We hope you have many years of wonderful boating experiences!

INTRODUCTION

Owner's manual

The material here and in the rest of the Owner's Manual Packet:

- Gives you basic safety information;
- Describes the features of your boat;
- Describes the equipment on your boat;
- Describes the fundamentals of boat use; and
- Contains service and maintenance information.

You must learn to operate this boat as well as read, understand and use this manual.

What this manual **does not** give you is a course in boating safety, or how to navigate, anchor or dock your boat. Operating a power boat safely requires more skills, knowledge and awareness than is necessary for a car or truck.

Your responsibilities

For your safety, the safety of your passengers, other boaters and people in the water, you must:

- Take a boating safety course;
- Get instruction in the safe and proper handling of your boat;
- Understand and follow the "rules of the road";
- Learn how to navigate.

Source of Information

In North America, contact one of the following for boating courses:

- U.S. Coast Guard Auxiliary
- U.S. Power Squadron
- Canadian Power and Sail Squadrons
- Red Cross
- State Boating Offices
- Yacht Club

Contact the Boat/U.S. Foundation at 1-800-336-2628 or go to www.boatus.com/foundation

Outside of North America, contact your boat dealer and/or your governmental boating agency for assistance.

A comprehensive background in boating can be found in the book, *Chapman - Piloting, Seamanship and Small Boat Handling*, by Elbert S. Maloney, published by Hearst Marine.

Warranties

In addition to the Boston Whaler® Limited Warranty for your boat, each component and/or system on your boat has its own warranty that will be found with the specific information and manual for that component. The manuals are included with your Owner's Manual Packet. Locate and read the individual warranties, then keep them together for easy future reference.

Contact Phone Numbers and Internet Addresses

Boston Whaler, Inc.

Phone.....1-877-294-5645
Internet www.bostonwhaler.com

United States Coast Guard

Phone.....1-800-368-5647
Internet www.uscgboating.org

Boat US Foundation

Phone.....1-800-336-2628
Internet www.boatus.com/foundation

Canadian Coast Guard

Phone.....1-800-267-6687
Internet www.ccg-gcc.gc.ca/

THIS PAGE INTENTIONALLY LEFT BLANK

Explanation of Safety Labels

The most important aspect of boating is safety. Although every effort is made to address the numerous issues regarding the safe usage of your boat, it is strongly recommended that you avail yourself of the training and knowledge available through boating safety courses, etc.

Warning Labels

Mounted at key locations throughout your boat are warning labels which advise the owner/operator of imperative safety precautions to follow when operating and/or servicing equipment.

The examples below indicate the level of hazard by color and explanation.



DANGER

Denotes an immediate hazard exists that **WILL** result in severe personal injury or death.



WARNING

Denotes hazards or unsafe practices that **MAY** result in severe personal injury or death.



CAUTION

Denotes hazards or unsafe practices that **COULD** result in minor personal injury, product or property damage.



NOTICE

Denotes information that is important to know prior to operation and/or maintenance, but is not hazard related.

Safety Precautions

The examples below are of precautions which appear throughout this manual and must be observed when operating or servicing your boat. Learn to recognize the degree of hazard and understand the explanations of safety prior to reading this manual.

Always use common sense in the operation and servicing of your boat.



DANGER

Denotes an immediate hazard exists that **WILL** result in severe personal injury or death.



WARNING

Denotes hazards or unsafe practices that **MAY** result in severe personal injury or death.



CAUTION

Denotes hazards or unsafe practices that **COULD** result in minor personal injury, product or property damage.

NOTICE

Denotes information that is important to know prior to operation and/or maintenance, but is not hazard related.

ATTENTION

Denotes information found in the owner's manual to call attention to the safe operation or certain features of this vessel.

SAFE Boating means:

- Knowing the limitations of your boat
- Following the “RULES of the ROAD”
- Keeping a sharp lookout for people and objects in the water.
- Not boating in water or weather conditions that are beyond the boat’s and operator’s capability.
- Never operating the boat while under the influence of drugs or alcohol.
- Being aware of your passengers safety at all times.
- Reducing speed when there is limited visibility, rough water, people in the water nearby , boats or structures.

In Addition:

- Maintain your boat and its safety and other systems as recommended in this manual.
- Have the boat inspected by a qualified mechanic or dealer, at least annually.
- Ensure that the Coast Guard required safety equipment is on board and functioning.

NOTICE

As a boat owner or operator, YOU are responsible for your safety and the safety of your passengers and other boaters.

Boating in beautiful weather and calm water conditions can be a wonderful experience. Boating however requires considerably greater skills than operating a land vehicle. Taking a boating course is the best way to prepare for a safe and enjoyable experience on the water.

- Take a Coast Guard, U.S. Power Squadron or equivalent boating safety course. (Call the Boat/U.S. Foundation at 1-800 336-2628 for information on available courses, or go to: “www.boatus.com/foundation” on the internet.)
- Get hands-on training on how to operate your boat properly.

Safe Boating Checklist

Before Departure

- Update checklists when equipment is added or modified.
- Weather-forecast safe
- Required documents-on board
- Navigation charts & equipment-on board
- Safety equipment-on board
- Safety training-passengers & crew instructed on procedures, location, and use of safety equipment.
- Drain plugs-installed
- Bilge pumps-working & clean
- Blower-working
- Navigation lights-working
- Horn-working
- Fuel system-no leaks or fumes
- Fuel filter-tight & clean
- Power steering fluid-filled (if applicable)
- Steering system-working smoothly & properly
- Battery-electrolyte level within range
- Float plan-filed with friend or relative

Trailing (if applicable)

- Boat position-secure on trailer
- Tiedowns-tight
- Winch-locked
- Trailer hitch-connected
- Engine clearance-in trailering position
- Safety chains-attached
- Electrical-Lights, brake lights, turn signals working
- Mirrors-adjusted for trailering

After Return

- PFD’s & other safety gear-dry, stowed for next use
- Fuel tanks-filled (allow for expansion) to prevent condensation
- Fuel system-no leaks
- Bilge pump-operating properly
- Bilge-clean, no leaks
- Float plan-notify person with whom you filed plan

General Considerations

- Know how your boat handles under different conditions. Recognize your limitations and the boat's limitations. Modify speed in keeping with weather, sea and traffic conditions.
- Instruct passengers on location and use of safety equipment and procedures.
- Instruct passengers on the fundamentals of operating your boat in case you are unable to do so.
- You are responsible for passenger's actions. If they place themselves or the boat in danger, immediately correct them.
- **Remember the "Rule of Thirds"**: Use one third of the fuel for the trip outbound, one third for the return trip, and keep one third for reserve.

Maintain Control

High performance boats require intimate knowledge of their handling characteristics for safe high speed operation.

- Learn the effects of trim, steering and throttle changes at gradually increasing levels of speed.
- Approach full throttle while adjusting trim for safe handling of the vessel.

On the water there are no marked traffic lanes, no traffic signs or lights, and boats have no turn signals. The boat operator must keep her or his attention focused not only on what's ahead but what's on the left, right and behind the boat.

The operator must always be alert to approaching boats (from the rear, right and left sides, as well as those ahead). There can be people in the water, partially submerged debris, and other navigational hazards such as rocks, sand bars or dangerous currents, to name a few.

Your passengers are relying on you to operate and maneuver the boat safely so that they are not in danger of going overboard. If you turn too quickly,

increase or decrease speed abruptly, your passengers are at risk of being thrown overboard or thrown about the boat.

When visibility becomes impaired because of weather or time of day, use navigational lights to ensure other boats can see you. In addition, if high bow angle causes reduced visibility, slow down to allow sufficient time to react if an emergency occurs.

Boarding

- Board only one person at a time.
- Never jump into boat. Step or climb into cockpit.
- Load gear after you are aboard. Carrying gear while boarding can cause you to lose balance.
- Distribute weight evenly.
- Instruct passengers where to sit during on-plane operation to reduce the possibility of falling overboard during high speed maneuvers.
- If gear is not immediately needed, stow it in secure areas.
- Safety gear must be immediately accessible at all times.

Impaired Operation

WARNING

CONTROL HAZARD-Federal laws prohibit operating a boat while under the influence of alcohol or drugs. These laws are vigorously enforced.

The detrimental effects of alcohol and drugs are increased by wind, waves and sun, and will decrease your response time and ability to act in critical situations. Give special attention to the effects of alcohol and drugs while boating. No other single factor causes as many marine accidents and deaths. Death or serious injury and damage to personal and private property can result from being impaired while operating a boat.

Operator's Responsibility

Your degree of enjoyment on the water depends on you, your equipment and other people who, like yourself boat responsibly. As a boat operator you should:

- Make sure that all occupants always wear a U.S. Coast Guard-approved life jacket while on the water.
- All boat operators should complete a boating safety course (a requirement in many states).
- All boat operators must become familiar with the proper operation of all vessel features prior to departure.
- Always maintain a safe speed.
- Be aware of conditions in every direction always when underway.
- Mind your wake. It can capsize a small boat or damage moored boats or other property. You are responsible for damage caused by your wake.
- Reduce speed and post a lookout to identify hazards when:
 - Visibility is impaired
 - In rough water
 - In congested waterways
- Display navigation lights between sunset and sunrise and during periods of restricted visibility, such as rain, fog, etc.

WARNING

A qualified operator must be in control of the boat at all times. Do not operate the boat while under the influence of alcohol or drugs. never operate your boat at speeds which exceed the operator's ability to react if an emergency develops. At night, turn on the appropriate navigation lights and cruise at a reduced speed that will allow you plenty of time to avoid dangerous situations.

WARNING

STABILITY HAZARD

- **Load boat properly. The manufacturer's load rating is the maximum allowed under normal conditions. Adjust downward if weather, water or other conditions are adverse.**
- **Allow passengers to ride only in areas that do not pose a hazard to themselves or the boat.**

DO NOT allow passengers to ride on the bow of a closed bow boat.

DO NOT allow several passengers to ride in the bow of a small open-bow boat, causing the boat to "plow" into the water.

DO NOT allow passengers to ride on the transom or gunwales.

DO NOT overload the stern.

- **Observe manufacturer's recommended seating and on-plane locations (See Pg. 2-6).**

PERSONAL INJURY HAZARD-Stay alert. Use of drugs, alcohol, or other substances which impair judgement poses a serious threat to yourself and others. The boat operator is responsible for the behavior of passengers.

DROWNING HAZARD-Boats must carry one wearable personal flotation device (PFD) for every passenger on board. Boats must have at least one throwable life preserver.

SLIPPING HAZARD-Wet decks are slippery. Wear proper footwear and use extreme caution on wet surfaces.

Legally Mandated Equipment (Minimum Required)

Consult your National Boating Law Enforcement Agency. The following equipment is the minimum required by the U.S. Coast Guard for a boat less than 26 ft. (7.9M) in length.

Personal Flotation Devices (PFD's)

One (1) Coast Guard approved Type I, II or III is mandatory for each person aboard.

One (1) throwable Type IV device is also required to be onboard.

A Type V device is acceptable (See page 1-8) if worn for approved use. **ALWAYS WEAR A PFD WHEN BOATING**

WARNING

There is rarely time to reach stowed life jackets in time of emergency. Boaters should always wear a properly fitting, approved life jacket when on the water.

Children and non-swimmers MUST wear PFDs at all times when aboard.

NOTICE

Depending on the state or country of operation, the operator of a vessel may be fined for failure to comply with local or national rules regarding PFD usage.

Fire Extinguishers (Portable)

If there is no fixed fire extinguishing system installed in the engine or generator spaces, the Coast Guard requires two (2) Type B-I or one (1) B-II fire extinguisher(s) be on board.

The American Boat & Yacht Council (ABYC) recommends that you carry three (3) A,B or C Type fire extinguishers on board and located within easy reach of the helm, Engine(s), and galley or passenger cockpit.

Whistle, Horn

You must have on board, some means of making a loud sound signal. Navigation rules require that a sound made by any audible device be capable of a four (4) second blast, and be audible for 1/2 mi. (.80 Km).

Visual distress Signals

If you operate your boat in coastal waters or on the Great Lakes, you must have a visual distress signals for day and night use on board. At least three (3) U.S.C.G. approved pyrotechnic devices marked with date showing service life must be carried, be readily accessible, in servicable condition and not be expired.

Store all pyrotechnic signals in a well marked, waterproof container.

Additional Recommended equipment for safe operation

In addition to the legally mandated equipment, the following items are necessary for safe boating, especially if your boat will be out of sight of land.

- First Aid kit
- Charts/Maps
- Visual distress signals (for day or night use)
- Marine VHF radio
- Moisture repellent
- Mooring Lines
- Fenders
- Waterproof flashlights
- High power spotlight
- Spare propeller
- Tool kit:
 - Screwdrivers, (phillips & flat)
 - Pliers, (regular, vise-grip, tongue & groove)
 - Wrenches, (box, open end, allen & adjustable)
 - Socket set, (metric and U.S.)
 - Electrical tape & duct tape
 - Hammer
 - Spare parts kit, (spark plugs, fuses, etc.)
- Compass
- Manual bilge pump
- GPS or LORAN
- Spare keys
- EPIRB-Emergency positioning-indicating radio beacon
- Boat hook
- Extra batteries
- Instruction manuals
- Lubricating oil

Carbon Monoxide (CO)

⚠ DANGER

- **Fumes from the engine(s), Generator(s) and other equipment and appliances that burn fuel contain Carbon Monoxide. Carbon Monoxide can kill you. Open all doors, hatches, curtains and windows to allow fresh air to circulate and dissipate the amounts of Carbon Monoxide present in enclosed spaces, especially when the boat is moored or anchored.**
- **Proper ventilation must be maintained, even during inclement weather to prevent dangerous levels of Carbon Monoxide build-up.**
- **Sleeping aboard a boat will require a working Carbon monoxide detection system, preferably in each sleeping quarter.**

Carbon Monoxide is an odorless, colorless, and tasteless, extremely toxic gas produced by engines, heaters, stoves or generators. When inhaled it combines with hemoglobin in the blood, preventing absorption of oxygen and is unlikely to be noticed until the person is overcome.

Prolonged exposure to low concentration or very short exposure to high concentrations can result in asphyxiation and death.

Symptoms of Carbon Monoxide poisoning include:

- Dizziness
- Headaches
- Ringing in the ears
- Nausea
- Unconsciousness

GET MEDICAL ATTENTION AS SOON AS POSSIBLE.

Symptoms of CO poisoning are often confused with seasickness or intoxication, so those affected may not receive the medical attention they need.

The poisoning victim's skin often turns cherry red. If CO poisoning is suspected, have the victim breathe fresh air deeply. If breathing stops, resuscitate. A victim often revives, then relapses because organs

are damaged by lack of oxygen.

Carbon Monoxide can accumulate in dangerous concentrations anywhere in or around your boat including on back decks, swim platforms, or in water around generator exhausts. CO can remain in or around your boat at dangerous levels even if your engine is no longer running.

Remember:

- If you can smell engine exhaust, you are inhaling CO.
- Changing course and speed to place boat heading into the wind can improve ventilation.

To minimize the danger of Carbon Monoxide accumulation when the Engine is running (or by use of fuel burning equipment.):

- Do not idle the engine without moving the boat for more than 15 minutes at a time.
- Inspect the exhaust system regularly.
- Operate all fuel burning appliances, such as charcoal, propane, LPG, CNG or alcohol cooking devices in areas where fresh air can circulate.

In the event an alarm activates:

- Evacuate enclosed areas immediately.
- Shut OFF any fuel burning equipment or appliances.
- Open hatches, doors, portlights, etc. to improve ventilation.
- If making way, head boat into the wind.

⚠ DANGER

Never ignore an alarm.

⚠ DANGER

Even in rainy cold weather, ventilation must be maintained to avoid Carbon Monoxide poisoning. You will get wet and/or cold.

Carbon Monoxide Accumulation Scenarios

Examples of accumulation of Carbon Monoxide
Fig. 1.7.1

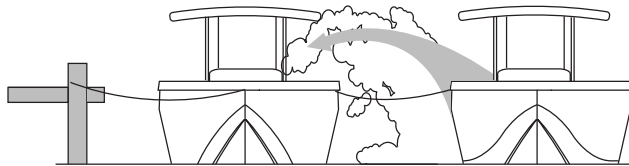

EXHAUST FROM OTHER BOATS

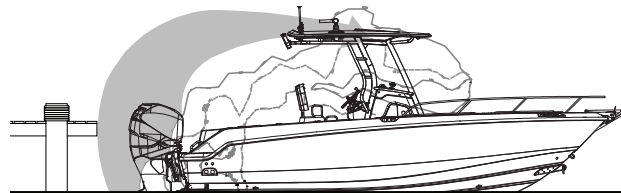

BLOCKAGE OF EXHAUST BY OBSTRUCTION

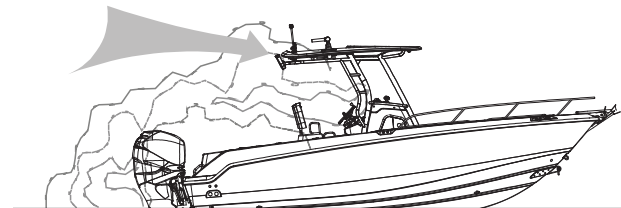

OPERATING AT A HIGH BOW ANGLE

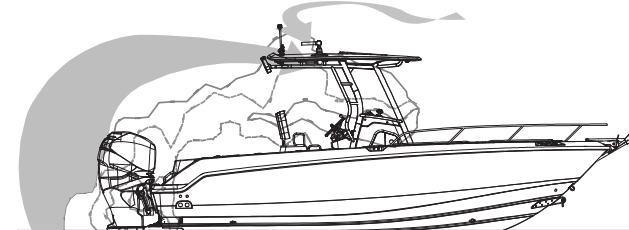

OPERATING AT SLOW SPEED OR WHILE IDLING
(STATION WAGON EFFECT)

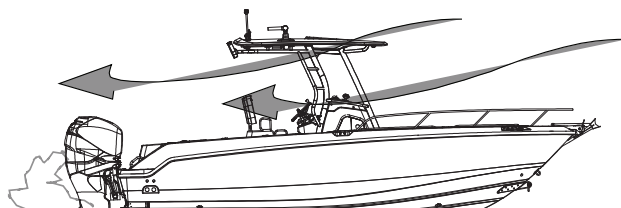

GOOD AIR FLOW

Lifesaving Equipment

Even strong swimmers can tire quickly in the water and drown due to exhaustion, hypothermia, or both. The buoyancy provided by a personal flotation device (PFD) will allow the person who has fallen overboard to remain afloat with far less effort and body heat loss, extending survival time necessary to find and retrieve them.

PFD Requirement

One (1) Coast Guard approved PFD, Type I, II or III for each person aboard or being towed on water skis, tubes, etc.

The law requires that PFDs must be readily accessible, if not worn. “Readily Accessible” means removed from storage bags and unbuckled.

NOTICE

Children and non-swimmers MUST wear PFDs at all times when aboard.

PFD Classifications

Listed below are the several different types of PFDs, each life jacket has different purposes, choose one that will suit your purpose.

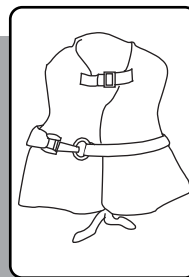

Type I, Off-shore Life Jacket is considered the most buoyant, it is designed to turn an unconscious person face up. Use in all types of waters where rescue may be slow, particularly in cold or rough water conditions.

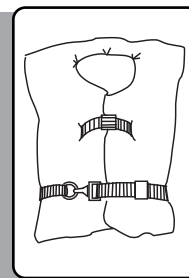

Type II, Near-shore Life Vest, “keyhole” vest with flotation filled head and neck support is also designed to turn a person face up, but the turning action is not as pronounced. Use in calm inland waters or where quick rescue is likely.

Section 1 • Safety

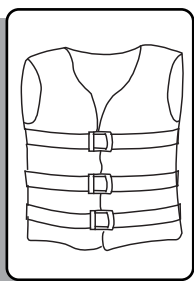

Type III, Flotation-aid Life vest is designed so that conscious wearers can turn face-up. Designed for comfort while engaged in water skiing or other forms of water activities.

Before purchasing PFDs, ensure that there is an attached tag indicating they are approved by the U.S.Coast Guard or by your National Boating Law Enforcement Agency.

The operator is responsible for instructing everyone onboard on their location and use. **The best precaution is to wear the PFD at all times while on the boat.**

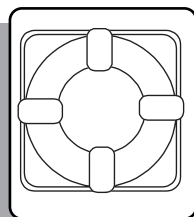

Type IV, Throwable Devices, horseshoe buoys, ring buoys and bouyant cushions are designed to be grasped, not worn.



Type V, Special-Use devices, sailboat harnesses, white water vests, float coats, and hybrid vests which have minimum inherent bouyancy and an inflatable chamber.

Emergency Situations

NOTICE

The law requires the owner/operator to assist any person or boat in distress as long as rendering assistance does not endanger the owner/operator, the passengers or the boat.

Prevention is the safest approach. We hope that you are never involved in an emergency situation, but if you are it is imperative that you react.

Medical Emergency

You may be far from professional medical help when you are boating. At least two (2) persons on board your boat should be CPR certified, and should have taken a first aid course. Your boat should have a well stocked first aid kit on board. In many situations your radio will be your only link to reaching medical assistance. Keep the radio in working order and understand which channels are used for emergencies, these channels are constantly monitored and will be useful when situations arise. Cell phones are becoming more common and can help in some areas, but they are limited and unreliable and should not be used in the place of a good VHF radio.

Water Rescue

In most situations a person that has fallen overboard will succumb to hypothermia if not rescued immediately. Life expectancy decreases as rescue time increases in water temperatures below 70° (21.1°C).

There are three (3) steps that must be taken when a person has fallen overboard:

1. Returning to the victim:

- Immediately make everyone onboard aware that someone is overboard and keep the victim in sight.
- Slow the boat and keep pointing toward the person overboard. At night or in low light, point the best available light source at the person.
- Throw a life ring/preserver to the victim, even if they are wearing one it will serve as another marker.

2. Making contact:

- Stop or slow the boat and circle toward the person overboard.
- Try to approach heading into the wind or into the waves.
- Keep person overboard constantly in sight.
- When almost alongside, stop the engine in gear to prevent propeller “windmilling”.

3. Getting back aboard:

- Try to reach the person overboard with a pole, or by throwing a life preserver. NEVER swim to them except as a last resort.
- Assist the person in boarding. Boarding should be done at the stern of the boat.
- If the person is injured or incapable of boarding by themselves, a rescuer should don a life preserver with a safety line and enter the water to assist the person onto the boat.
- Handle the person carefully, spinal injuries might have occurred and could be worsened by rough handling.
- Check for other injuries, render medical assistance immediately.

Unassisted Reboarding

The transom ladder (See page 3-14) can be deployed to accommodate a person reboarding the boat without assistance.

Fire

Fire is a serious boating hazard. Boats will burn quickly. Do not remain onboard and fight a fire for more than a few minutes. If the fire is out of control and cannot be put out with the fire suppression equipment onboard, abandon ship immediately.

The fumes released during a fire are toxic and should be avoided. Even after the fire has been extinguished, proper ventilation of the area is required to minimize exposure to harmful fumes.

DANGER

- **Fires can spread quickly. Your reaction to the fire is important. Have the proper fire fighting equipment close at hand, and in good working order to respond quickly.**
- **Small fire extinguishers have small discharge times. Aim at the base of the fire with a sweeping motion to maximize the use of the fire extinguisher contents.**

To lessen the danger of fire:

- Extinguish all smoking materials, shut off blowers, stoves, engine(s) and generator(s).
- Keep bilge area clean, oil and fuel spills should be cleaned immediately.
- If possible throw burning materials overboard.
- If fire is accessible, release the contents of the fire extinguisher(s) into the base of the fire.
- If the fire is in an enclosed compartment, and you have an automatic extinguisher for the compartment, wait 15 min. before opening the compartment. Have an extinguisher handy in case of a flare up.
- If possible, signal for help. Radio, visual, and audible signal should be used as needed. You must render assistance to any boater requesting help.
- If fire is out of control, grab all necessary survival gear, distress signals, don your PFD's and prepare to abandon ship.
- If you do abandon ship, make sure the passengers have PFD's. Take a head count before entering the water and take another head count when in the water. **STAY TOGETHER.**

Flooding, Swamping and Capsizing

In the event of Flooding, Swamping or Capsizing:

Flooding-

- Always wear your PFD, or have it within reach.

- If the bilge pump(s) have not automatically turned ON, switch them ON immediately.
- Find the source of the flooding and determine the best fix.
- Keep the bilge pumps running until the flooding is under control.
- Call for assistance if the source of the flooding cannot be controlled.
- Head back to port if possible.

Swamping-

- Always wear your PFD, or have it within reach.
- Swamping is usually a result of wave action, immediately get control of the helm and turn the boat into the waves.
- Swamping can also be caused by an overloaded boat.
- If the bilge pump(s) have not automatically turned ON, switch them ON immediately.
- The deck scuppers on your boat are designed to drain the deck of water.
- Keep the bilge pumps running until the flooding is under control.
- Take a head count of all passengers.

Capsizing-

- “Capsized” is when a boat is on its side or completely upside-down (usually as a result of wave action, improper loading or load shifting).
- If the boat will not right itself, get out of the water and climb onto the exposed hull.
- Do a head count for all passengers
- **STAY TOGETHER**
- Usually a capsizing will happen quickly and without warning.
- Use whatever is at hand to signal for help.

The chances of flooding, swamping or capsizing can be reduced by being aware of:

- Weather
- Water Conditions
- Proper boat handling techniques
- Proper loading of the boat

Collision

In the event of collision:

- Cut the engine(s)
- Check on passengers
- If the bilge pump(s) have not automatically turned ON, switch them ON immediately.
- Determine the amount of damage to your boats structure.
- Call for assistance
- In the event of collision you are required to file an accident report. Contact a state enforcement agency or the nearest U.S. Coast Guard office. If you are boating outside U.S. waters, consult the nation you are visiting for accident reporting requirements.

Propulsion, Control or Steering failure:

If there is a propulsion, control or steering failure:

- Stop the engine, (shut off at Ignition or pull on the Emergency Engine Shut-Off Switch.)
- Drop anchor to prevent drifting.
- Determine if the problem can be fixed or will assistance be needed.
- Call for assistance if needed.

When loss of propulsion or steering is noticed, your quick reaction is required to prevent further damage to your boat or injuries to your passengers.

Outboard engines require propulsion to control the direction the boat will take. Without propulsion, the steering is virtually useless. If you are in a congested waterway you will need to react quickly to warn

others that you have lost power, propulsion or steering control and that assistance will be needed.

Grounding

Running aground may be avoided by paying attention to marker bouys or indicated by waves as they form into breakers when passing over a sand bar.

If you do run aground, the course of action depends on how hard the boat hits bottom and whether the boat remains stranded. If it is a simple touch, you may need only to inspect the lower drive of the engine and the hull of the boat. If possible do a thorough inspection before trying to get loose, throwing the boat into reverse before this is done may do more damage.

Distress Signals

Visual Distress Signals, (VDS)

- U.S. Coast Guard regulations require boats in coastal waters and the Great Lakes to carry a Visual Distress Signal (VDS) for day and night use, as well as appropriate for the time of operation. Exempt from the day signals requirement, but not night signals, are boats less than 4.8 meters (16 feet), open sailboats less than 7.9 meters (26 feet), boats participating in organized events and manually propelled boats.
- If you are required to have visual distress signals, at least three safety approved pyrotechnic devices in serviceable condition must be readily accessible. They must be marked with a date showing the service life which must not be expired.
- Carry three signals for day use and three for night use. Some pyrotechnic devices such as red flares, meet both day and night use requirements.
- Store pyrotechnic signals in a cool, dry location. An orange or red watertight container prominently marked "DISTRESS SIGNALS" is recommended.

Other recognized visual distress signals include:

- Flames in a bucket
- Code flags November & Charlie
- Black square & ball on orange background flag.
- Orange flag (certified)
- Electric distress light (certified)-for night use
- Dye marker (any color)
- Person waving arms (slowly)
- U.S. ensign flown upside down

Audible Distress Signals, (ADS)

U.S. Coast Guard regulations require one hand, mouth or power operated whistle or horn, audible for at least 1/2 mile.

Other recognized audible distress signals include:

- Radio communication (see **Radio Communication** below)
- Radio-telegraph alarm
- Position indicating radio beacon
- Morse Code S-O-S (3 short 3 long 3 short) sounded by any means.
- Fog horn sounded continuously.

Radio Communication

A radio is the boat operator's main method of receiving safety information and summoning aid. VHF-FM radio is the primary means of short range communication. Single sideband radio (SSB) is used for longer range communication.

VHF-FM channel 16 and SSB 2182 kHz are designated for emergency use. Such situations can be categorized as:

- **EMERGENCY-**
“MAYDAY, MAYDAY, MAYDAY,”- used when life or vessel is in imminent danger.

- **URGENCY-**

“PAN-PAN, PAN-PAN, PAN-PAN” (pronounced PAHN-PAHN)-used when a person or vessel is in some jeopardy less than indicated by a “MAYDAY” call.

- **SAFETY-**

“SECURITY, SECURITY, SECURITY” (pronounced SAY-CURE-IT-AY)-used for navigational safety or weather warning.

An emergency situation will be hectic and there will not be time to learn proper radio procedure. **LEARN WHAT TO DO BEFORE YOU NEED TO DO IT.** If you hear a distress call, stop all radio transmissions. If you can directly assist, respond on the emergency frequency. If you cannot assist, do not transmit on that frequency. However, continue to monitor until it is obvious that help is being provided.

Weather

⚠ DANGER

DO NOT attempt to boat in severe weather conditions. Death or serious injury can occur. Get to shore before the weather turns bad.

Getting caught in severe weather is hazardous. Bad weather and/or rough sea or water conditions can cause an unsafe situation. Consult local weather services for up-to-date forecasts on weather and sea conditions. Television, Radio, Internet can give you access to NOAA weather reports that will help you make a determination on where and when to get underway.

Following are some weather related rules:

- Understand the design limitations of your boat.
- Check the weather forecast and water conditions before leaving and while underway.
- Wear a Personal Flotation Device, (PFD)

! WARNING

A sudden change in wind direction or speed or an increase in wave height indicates deteriorating weather.

NOTICE

Check the weather forecast and water conditions before leaving and while underway

Weather Warning Penanats
Fig. 1.13.1

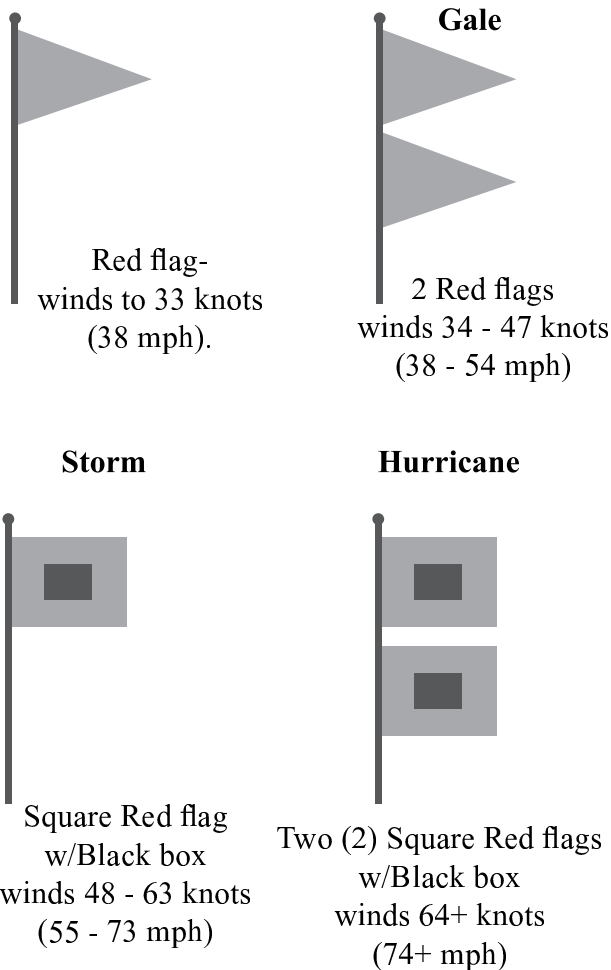

- If a storm approaches, immediately seek a safe harbor.
- If a storm hits have everyone sit in the cabin or cockpit deck in the boat. Head the bow into the wind with enough power to maintain slow headway.

- If you encounter fog, determine your position, set a safe course, slow down and alert other boats of your presence with a sound signal.
- If a lightning storm approaches, the safest action is to dock and disembark. If you cannot return to shore, have passengers go inside the cabin and remain there until the storm passes.
- Stay out of the water during a lightning storm. If caught swimming during a storm, get back into the boat and remain there until the storm passes. (remember that lightning can strike several miles away from the storm itself. Be aware of the storms location relative to your location and the direction the storm is moving).

Swimming, Diving & Water Skiing

Swimming

- Do not swim from a moving boat.
- Many areas prohibit swimming from a boat except in designated areas.
- Turn off engine in gear (to prevent propeller “windmilling”) before picking up swimmer.

Diving

Recognize and respect diving flags. Keep at least 30 meters (100 ft.) away.

Diver's Flags
Fig. 1.13.2

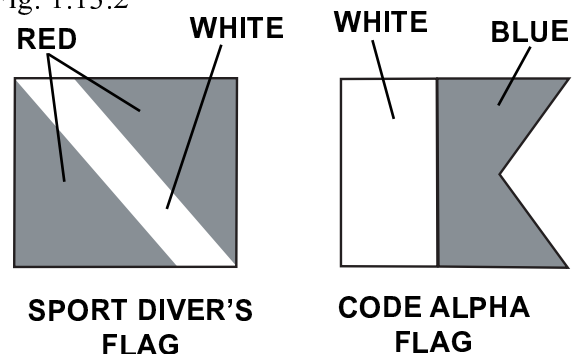

SPORT DIVERS FLAG-Red flag with diagonal white stripe marks a diver in the water.

CODE ALPHA FLAG-Blue and white pennant designates boat being used in dive operations.

Water Skiing

- Always have two persons in the boat, one at the controls and one who can easily and continuously look at the skier.
- Insist that anyone who water skis must know how to swim.
- Insist that skiers wear approved Personal Flotation Devices (PFD's)
- Ski only in daylight when visibility is good.
- Never drive the boat directly behind a water skier. At 22 knots (25 m.p.h.), it takes only 5 seconds to overtake a fallen skier who was 60 meters (200 feet) in front.
- Ski only in areas where skiing is permitted.
- Observe local restrictions on length of tow line.
- Learn the signals to communicate with a skier. The skier is to control the boat through hand signals (Figure 1.14.1).
- Your boat will handle differently while towing a skier. Experiment carefully to learn the difference.
- Skiers may start from the shore or dock, if boat traffic allows. When returning, pick up skiers from water. Do not ski back to shore or dock.
- Give immediate attention to fallen skiers.
- Keep a downed skier in sight and on the operator's side of the boat when approaching the skier. **Never back up to anyone in the water.**
- Turn off engine in gear (to prevent propeller "windmilling") before picking up skier.
- If the skier suddenly releases the tow rope, it can backlash into cockpit. Spotters who are watching the skier must be aware of this fact and be prepared to take appropriate action to avoid injury.

Water Skiing Signals

Skiing Signals

Fig. 1.14.1

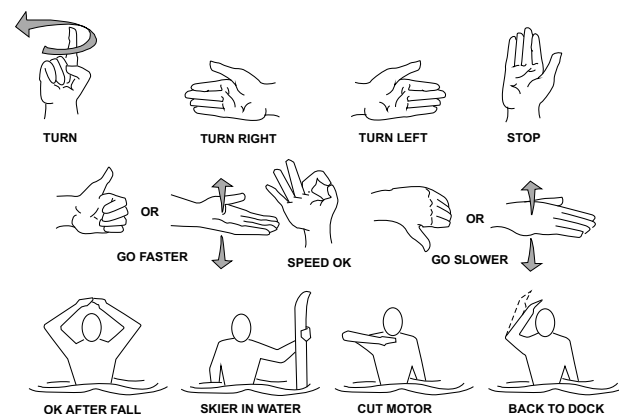

Turn – Arm raised, circle with index finger extended.

Turn Right – Extend arm out from body to the right.

Turn Left – Extend arm out from body to the left.

Stop – Raise arm with palm vertical and facing forward.

Faster – Thumb pointed up or palm up, move hand up and down.

Speed OK – Raise arm and form a circle with thumb and index finger.

Slow Down – Thumb pointed down or palm down, move hand up and down.

OK After a Fall – Clasp hands together overhead.

Skier in Water – Extend one ski vertically out of water.

Cut Motor – Draw finger across throat.

Back to Dock – Pat top of head.

 **WARNING**

SWIMMING/DIVING HAZARD

- Keep clear of areas designated only for swimmers and skin divers. Recognize markers used for such areas.
- Never swim when there is lightning in the area.

SKIING HAZARDS

- Skiers must use a safety approved Personal Flotation Device (PFD).
- Ski only during daylight and in good visibility.
- Avoid shallow water, other boats, navigational aids and other obstructions.
- Keep at least 30 meters (100 ft.) from other objects.
- Never drive directly behind a water skier.
- A competent observer must watch the skier at all times. A competent observer is a person that has the ability to assess when a skier is in trouble, knows or understands water skiing hand signals and is capable of helping a skier.
- Keep a downed skier in constant sight.
- Turn off engine in gear before you get close to person in the water.
- Never back up to anyone in the water.
- Use caution in boat when skier is being towed. Sudden release of tow rope can cause it to backlash into the cockpit.

PERSONAL INJURY HAZARD

Use transom tow ring only to pull water skiers. Unless specified by the manufacturer, any other use, such as parasailing, kite flying, towing other boats, etc. may create too much stress on the tow ring, resulting in personal injury and/or equipment damage.

 **DANGER**

PROPELLER SAFETY

- Before starting your boat, walk to the stern and look in the water to assure there is no one near your propeller.

People near propeller may not be visible from helm.
- NEVER allow passengers to board or exit your boat from the water when engines are on.
- Educate passengers about the dangers of propellers
- Be especially alert when operating in congested areas. NEVER enter swimming zones.
- Take extra precautions near boats that are towing skiers or tubers.
- NEVER permit passengers to ride on the bow, gunwale, transom, seatbacks, or other locations where they may fall overboard.
- STOP! if someone falls overboard. Slowly turn the boat around, and keep the person in sight as you approach. Turn your engine off FIRST and then bring the person aboard.
- NEVER reverse your boat to pick someone up out of the water.

Ignition Shutdown Safety Switch

! WARNING

Wear the lanyard at all times when operating the boat. Use it to stop only in an emergency. DO NOT use it to shut off the engine during normal operation

Your boat is equipped with an ignition shutdown safety switch. The switch is located below the gear shift/throttle control unit. The ignition shut down safety switch incorporates a shut-off switch, switch clip, lanyard and lanyard clip, which is clipped to the operator when running.

If an emergency arises and the engine must be shut down, a pull on the cord to release the clip from the shut-off will shut off the engine.

This switch is designed to shut the engine off when the operator of the boat leaves the control station, either accidentally by falling into the boat, or by being ejected overboard. This would most likely occur as a result of poor operating practices.

The lanyard should be long enough to prevent inadvertent activation. Do not let the lanyard become entangled.

Accidental loss of power can be hazardous, particularly while docking or in heavy seas, strong current or high winds. Passengers and crew may lose balance and the boat may lose steering control.

Should the operator fall out of the boat at planing speed, it may take several seconds for the engine and propeller to stop turning. The boat may continue to coast for several hundred feet, causing injury to anyone in its path.

Float Plan

Float plans are important to you should you encounter problems on the water. A float plan should contain a description of your boat along with any distinguishing features. It should describe where you will be boating, your departure time and estimated return. The number and names of passengers, and destination should also be noted.

The float plan should be given to a friend or relative, so they can give the information to a national boating agency like the U.S. Coast Guard, in the event you do not return at the time specified on the float plan.

If there are any changes to the float plan they should be conveyed to the person holding the float plan. Once you return you should contact the person holding the float plan to let them know you are back.

Chart Your Course

To avoid boating in unsafe areas where there are underwater obstructions, shallow water, unnavigable conditions such as dangerous currents, and others, you must chart a course. This means having and using National Oceanic and Atmospheric Administration (NOAA) charts for coastal waters, observing and understanding all navigational aids, using the knowledge and guidance of experienced boaters, and being aware of the tides and times where appropriate. If you are boating in an area you are unfamiliar with, proceed with caution and post a lookout to watch for hazards.

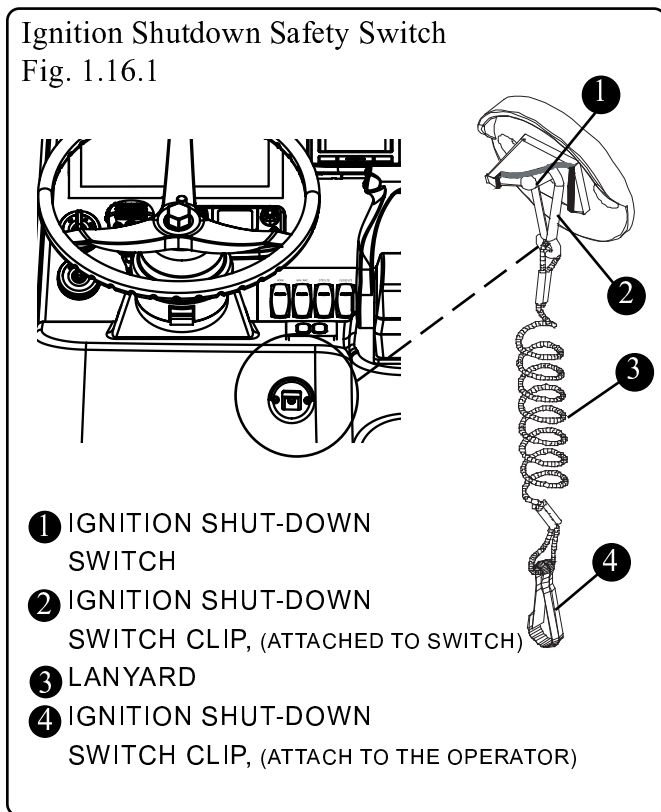

WARNING

Hitting an object in or under the water or boating in dangerous currents can cause serious injury or death to occupants in the boat.

You must know where the hazards are and avoid them. In uncharted waters, boat very slowly and post a lookout.

If an object is struck or if you run aground:

- **Shut the engine OFF**
- **Check the hull for damage**
- **Check propeller for damage**
- **If aground, consider the bottom grade before moving off, (damage to the hull and propellers could be worsened).**
- **Determine the tides and whether it will help or hinder you from the grounding.**
- **Do not have anyone other than a trained and competent service tow your boat.**

Environmental Considerations

Fuel & Oil Spillage

Regulations prohibit discharging fuel or oily waste in navigable waters. Discharge is defined as any action which causes a film, sheen or discoloration on the water surface, or causes a sludge or emulsion beneath the water surface. A common violation is

bilge discharge. Use rags or sponges to soak up fuel or oily waste, then dispose of it properly ashore. If there is much fuel or oil in the bilge, contact a knowledgeable marine service to remove it. Never pump contaminated bilge overboard. Help protect your waters.

Excessive Noise

Many areas regulate noise limits. Even if there are no laws, courtesy demands that boats operate quietly.

Wake / Wash

Power boat wakes can endanger people and vessels. Each power boat operator is responsible for injury or damage caused by the boat's wake. Be especially careful in confined areas such as channels or marinas. Observe "no wake" warnings.

WARNING

SPEED HAZARD - Watch your wake. It might capsize a smaller craft. You are responsible for damage caused by your wake.

CAUTION

Reduce speed in congested waterway. Be alert for No Wake markers.

Homeland Security Restrictions

Recreational boaters have a role in keeping our waterways safe and secure. Violators of the restrictions below can expect a quick and severe response.

- **DO NOT** approach within 100 yards, and slow to minimum speed within 500 yards of any U.S. Naval vessel. If you need to pass within 100 yards of a U.S. Naval vessel for safe passage, you must contact the U.S. Naval vessel or the Coast Guard escort vessel on VHF-FM channel 16.

DANGER

DO NOT approach within 100 yards of any U.S. Naval vessel without first contacting the vessel on VHF-FM channel 16. To do so will result in a quick and severe response.

- Observe and avoid all security zones. Avoid commercial port areas, especially those that involve military, cruise line or petroleum facilities. Observe and avoid other restricted areas near dams, power plants, etc.
- **DO NOT** stop or anchor beneath bridges or in channels.

America's Waterway Watch

In March, 2005, the U.S. Coast Guard officially launched *America's Waterway Watch* to encourage the boating public to report suspicious activities in our nation's ports and waterways. *America's Waterway Watch* simply asks anyone who works, lives, or recreates on the water to keep an eye out for suspicious activities. Anyone who spots such activity is asked to call the National Response Center's 24-hour hotline, 800-424-8802 or 877-24WATCH (877-249-2824).

Warning Label Locations

Mounted at key locations throughout the boat (See pages 1-19 thru 1-22), warning labels advise the owner/operator of imperative safety precautions to follow when operating and/or servicing equipment. **DO NOT REMOVE OR OBSTRUCT ANY WARNING LABEL.** Replace any label which becomes illegible.

Warning Label Locations

Warning Label Locations
Fig.1.19.1

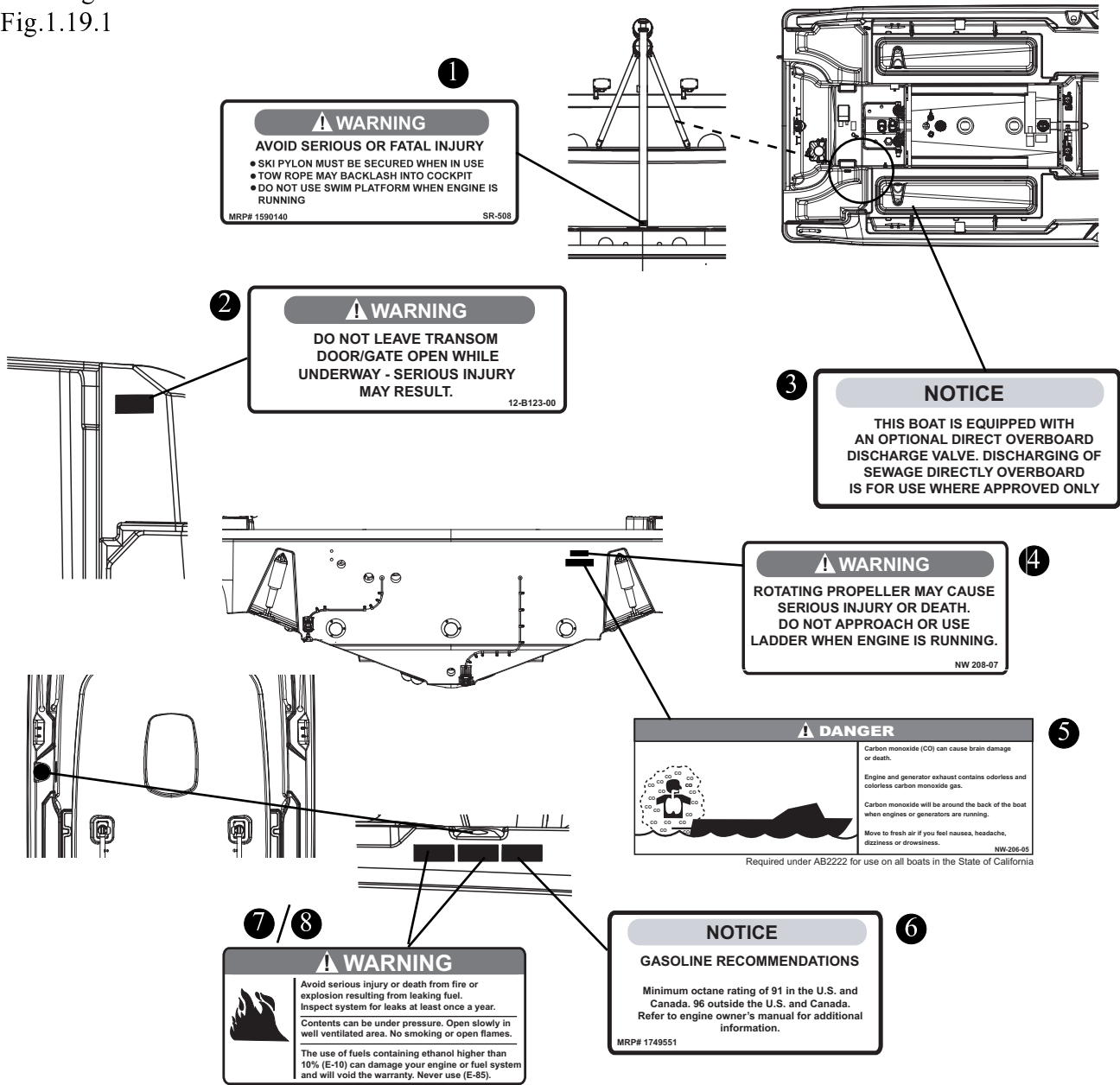

Replacement Part No.

- 1** WARNING, SKI PYLON/TOW ROPE (OPTION) 1590140
- 2** DANGER TRANSOM DOOR 2063385
- 3** NOTICE, OVERBOARD DISCHARGE (OPTION)..... 2063381
- 4** WARNING, ROTATING PROP DANGER..... 1903624
- 5** DANGER, CO TRANSOM 1811367
- 6** FUEL RECOMMENDATION 2038447
- 7** WARNING, FUEL HAZARD 2096004
- 8** FUEL HAZARD CANADIAN(OPTION) 2175077

NOTICE

It is important to replace any damaged or unreadable label. Call your Boston Whaler dealer for replacement labels.

Warning Label Locations (Con't)
Fig.1.20.1

Proposition 65

WARNING

A WIDE VARIETY OF COMPONENTS USED ON THIS VESSEL CONTAIN OR EMIT CHEMICALS KNOWN TO THE STATE OF CALIFORNIA TO CAUSE CANCER AND BIRTH DEFECTS AND OTHER REPRODUCTIVE HARM.

EXAMPLES INCLUDE:

- ENGINE AND GENERATOR EXHAUST
- ENGINE AND GENERATOR FUEL, AND OTHER LIQUIDS SUCH AS COOLANTS AND OIL, ESPECIALLY USED MOTOR OIL
- COOKING FUELS
- CLEANERS, PAINTS, AND SUBSTANCES USED FOR VESSEL REPAIR
- WASTE MATERIALS THAT RESULT FROM WEAR OF VESSEL COMPONENTS
- LEAD FROM BATTERY TERMINALS AND FROM OTHER SOURCES SUCH AS BALLAST OR FISHING SINKERS

TO AVOID HARM:

- KEEP AWAY FROM ENGINE, GENERATOR, AND COOKING FUEL EXHAUST FUMES
- WASH AREAS THOROUGHLY WITH SOAP AND WATER AFTER HANDLING THE SUBSTANCES ABOVE

CALIFORNIA RESIDENTS ONLY
THIS WARNING IS ATTACHED TO THE STEERING WHEEL PRIOR TO DELIVERY OF ANY BOATS SOLD IN THE STATE OF CALIFORNIA IN ACCORDANCE WITH CALIFORNIA HEALTH & SAFETY CODE §§ 25249.5-.13

Required under AB2222 for use on all boats in the State of California

WARNING

Carbon monoxide (CO) can cause brain damage or death.
Engine and generator exhaust contains odorless and colorless carbon monoxide gas.
Signs of carbon monoxide poisoning include nausea, headache, dizziness, drowsiness, and lack of consciousness.
Get fresh air if anyone shows signs of carbon monoxide poisoning.
See Owner's Manual for information regarding carbon monoxide poisoning.

NW-204-05

ATTACH LANYARD

WARNING

ROTATING PROPELLER MAY CAUSE SERIOUS INJURY OR DEATH.
SHUT OFF ENGINE WHEN NEAR PERSONS IN THE WATER.

CAUTION

AVOID DAMAGE TO ENGINE COWL.
REMOVE SKI PYLON BEFORE RAISING ENGINE OR TRAILERING BOAT

MRP# 1752493

WARNING

VISIBILITY FROM THIS HELM STATION IS LIMITED.
AVOID COLLISIONS-MAINTAIN LOOKOUT AS REQUIRED IN 'RULES OF THE ROAD' BY U.S. COAST GUARD.

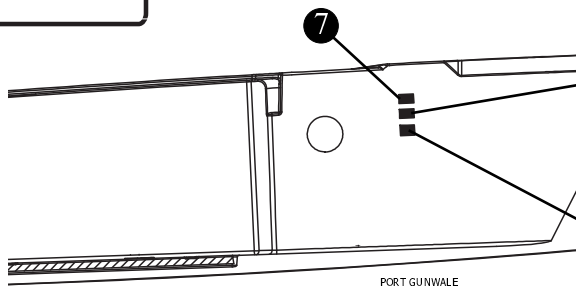

THIS BOAT HAS BEEN DESIGNED FOR A MAXIMUM OUTBOARD ENGINE WEIGHT OF

1400 Lb / 635 kg

THIS LABEL DELETED WHEN AUSTRALIAN BUILDER'S PLATE IS USED.

EMISSIONS CONTROL SYSTEM INFORMATION

MEETS 2021 MY CALIFORNIA EVAP EMISSIONS REGULATIONS FOR SPARK-IGNITION MARINE WATERCRAFT (SIMW)
MANUFACTURER: BOSTON WHALER, INC.
CALIFORNIA EVAP FAMILY: MBNWPVSSLNT1
EMISSION CONTROL SYSTEM: SP

MRP# 2358006

Replacement Part No.

1	PROPOSITION 65 HANG TAG	1795087
2	WARNING, CO HELM	1811368
3	DECAL, WEAR YOUR LANYARD	2156485
4	WARNING, LTD VISIBLTY (OPTION)	1752856
5	CAUTION, REMOVE PYLON	1752493
6	WARNING, PROP DANGER	1950698
7	BUILDER'S PLATE	SEE FIG. 2.2.1
8	MAXIMUM ENGINE WEIGHT	1774308
9	LABEL, CALIFORNIA ARB COMPLIANCE	2358006

NOTICE

It is important to replace any damaged or unreadable label. Call your Boston Whaler dealer for replacement labels.

Section 1 • Safety

Warning Label Locations (Con't)

Fig.1.21.1

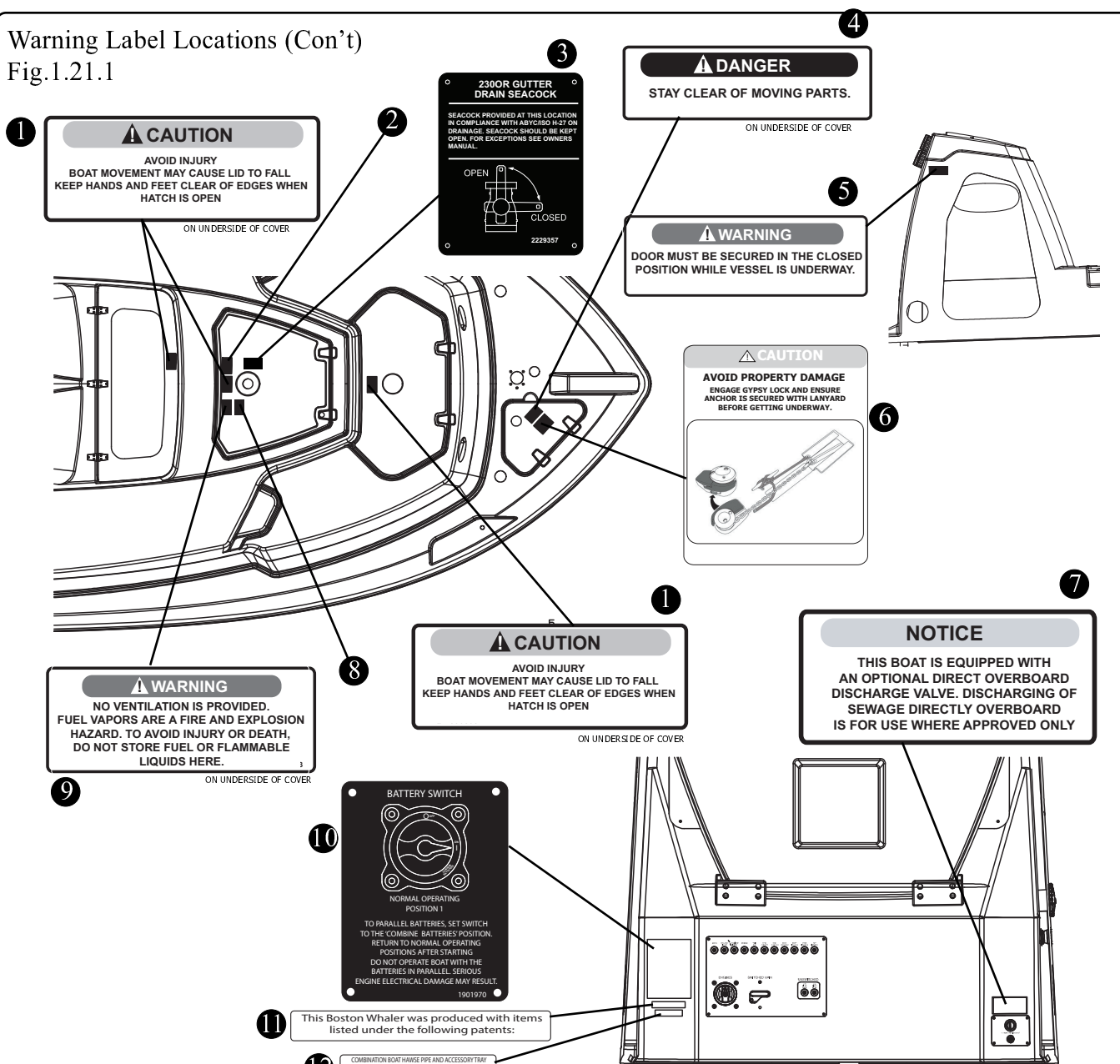

Replacement Part No.





1	CAUTION, AVOID INJURY, BOAT MOVEMENT	1836858
2	CAUTION, FISHWELL DRAIN	2049272
3	PLATE, SEACOCK	2229357
4	DANGER, STAY CLEAR OF MOVING PARTS	2028932
5	WARNING, DOOR SECURED	2063402
6	CAUTION, SECURE ANCHOR	2147835
7	NOTICE, OVERBOARD DISCHARGE (OPTION)	2063381
8	WARNING, DO NOT STORE FUEL (CANADIAN)	2175076
9	WARNING, DO NOT STORE FUEL	1691003
10	BATTERY PARALLEL DETAILS	1901970
11	LABEL, PATENT HEADER	2088481
12	LABEL, PATENT HAWSE PIPE/DRINKHOLDER	2063995

NOTICE
It is important to replace any damaged or unreadable label. Call your Boston Whaler dealer for replacement labels.

Section 1 • Safety

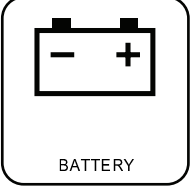
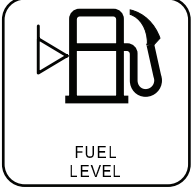
Key to Symbols on Controls & Prints

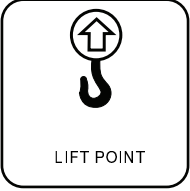
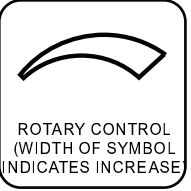
Although not used in this manual, some of these symbols may be found on the controls, gauges, and hardware on your boat. This page is to help you understand what the symbols mean.

 PROPULSION SYSTEM TRIM	 TRIM TAB TRIMMING OPERATION	 ENGINE START	 ENGINE STOP	 BATTERY	 OIL	 WARNING ELECTRICAL HAZARD	 FIRE RISK	 NO OPEN FLAME NO SMOKING
 FUEL GENERAL	 FUEL LEVEL	 LEADED FUEL	 UNLEADED FUEL	 FRESH WATER	 GRAY WATER			
 BILGE PUMP	 OUTBOARD DRIVE	 OUTBOARD DRIVE TILT	 PROPELLER	 SEAWATER	 SEWAGE			
 PUMP	 SINGLE LEVER CONTROL	 LIFT POINT / SLING LOCATION	 LIFT POINT	 RUNNING LIGHTS UNDER POWER	 ROTARY CONTROL (WIDTH OF SYMBOL INDICATES INCREASE)			
 ANCHOR	 ANCHOR LIGHT	 INTERIOR LIGHT	 HORN	 WINDSHIELD WIPER AND WASHER	 MAGNETIC COMPASS			

Construction Standards

Boston Whaler® is dedicated to creating a superior product which will provide comfort, performance, safety and dependability. All of our boats comply with the safety standards set by the United States Coast Guard and are designed, engineered and manufactured in accordance with applicable recommendations and guidelines of the American Boat and Yacht Council (A.B.Y.C.) and certified by the National Marine Manufacturers Association (NMMA).

Our Hull

Boston Whaler® hulls are constructed with our patented Unibond™ construction process. This involves foam injection into a closed mold system where the foam expands to fill all voids in the hull. When the finished product is pulled from the mold, the hull and deck are chemically bonded to form a solid, inseparable unit.

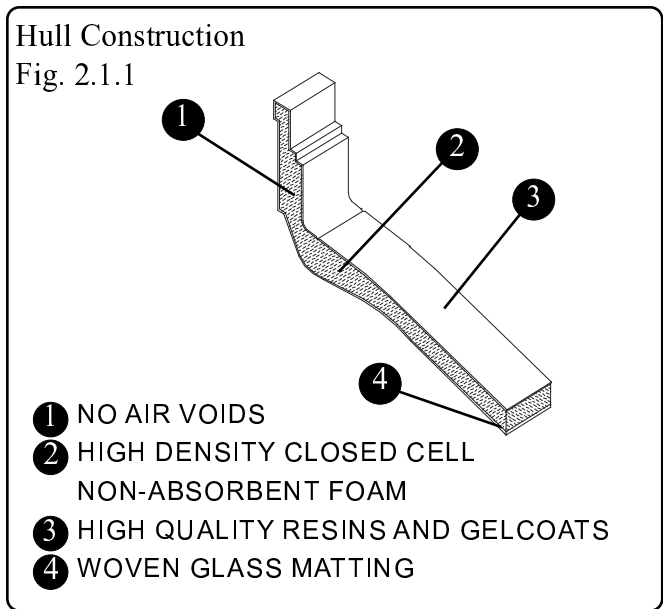

Hull Identification Number

The “Hull Identification Number” is located on the starboard side of the transom.

This is the most important identifying factor and must be included in all correspondence related to your vessel. Also of vital importance are the engine serial numbers, part numbers, etc. when writing about or ordering parts for your engine.

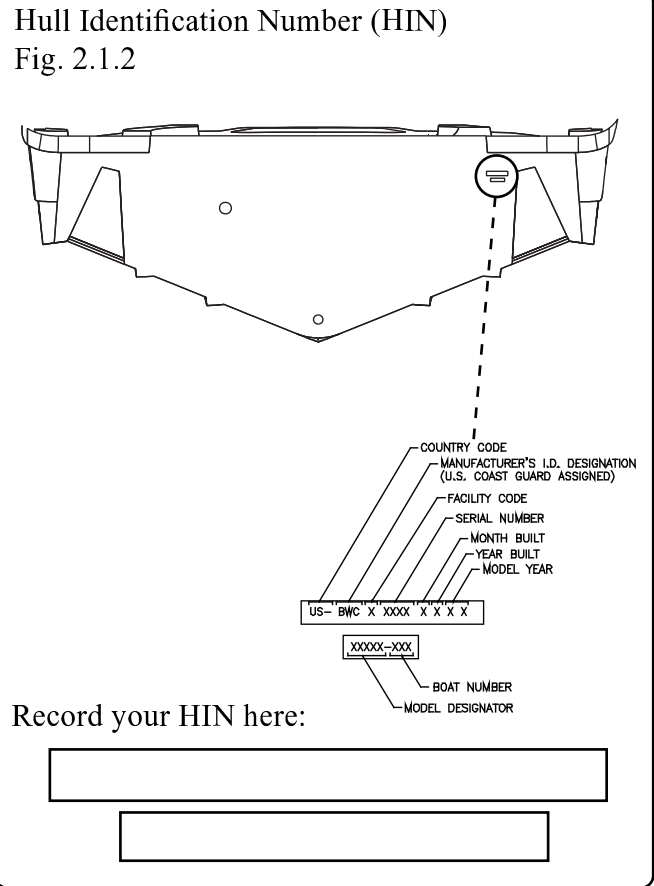

Servicing Your Boston Whaler

When your Whaler requires service or maintenance work, it should be taken to an authorized Boston Whaler® dealer.

To find a Boston Whaler® dealer in your area call:
1-800-942-5379 (Domestic/International).

In the unlikely event that a problem is not handled to your satisfaction, discuss any warranty related problems directly with the service manager of the dealership or your sales person. Give the dealership an opportunity to help the service department resolve the matter for you.

Manufacturer's Certification

All boats must comply with federal regulations regarding maximum capacities. The “Specifications & Dimensions” list on the bottom of page 2-4 indicates the maximum weight, number of persons, and maximum horsepower your boat is rated to handle. **DO NOT exceed these specifications.**

⚠ DANGER

NEVER carry more weight or passengers than indicated for your boat, regardless of the weather or water conditions.

The number of persons on board must be reduced if you go out in poor weather and rough water.

The information present on the certification plate does not relieve the operator of responsibility. Use common sense and sound judgement when placing equipment and/or passengers in your boat.

- Do not load to capacity in poor weather or rough water.
- The number of seats does not indicate how many people a boat can carry in poor weather and rough water
- Above idle speed, all passengers must be seated on the seats provided.

An **NMMA Certification** means that your Boston Whaler® has been judged by the National Marine manufacturers Association to be in compliance with applicable federal regulations and American Boat and Yacht Council standards.

A **Canada Conformity Sticker** means that your Boston Whaler® has been certified to comply with construction standards for small vessels by Transport Canada.

A **CE mark** means that your Boston Whaler® has been certified with the applicable international Organization for Standardization directives.

An **Australian Builder's plate** means that your Boston Whaler® has been certified to comply with safety standards set by the National Marine Safety Committee.

Certification Plates

Fig. 2.2.1



Replacement Part No. 2339772

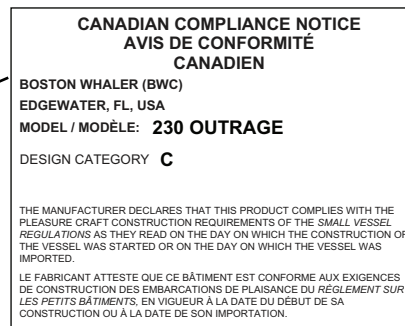

Replacement Part No. 2219576

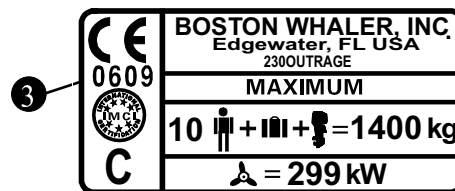

Replacement Part No. 2339774



Replacement Part No. 2339775

- ① NMMA CERTIFICATE
- ② CANADA CONFORMITY STICKER
- ③ CE MARK (INT'L) BUILDER'S PLATE
- ④ AUSTRALIAN BUILDER'S PLATE

Section 2 • General Information

Certification Design Category

A: A recreational craft given design category A is considered to be designed for winds that may exceed wind force 8 (Beaufort scale) and significant wave heights of 4 meters and above but excluding abnormal conditions, such as storm, violent storm, hurricane, tornado and extreme sea conditions or rogue waves.

B: A recreational craft given design category B is considered to be designed for a wind force up to, and including, 8 and significant wave heights up to, and including 4 m.

C: A watercraft given design category C is considered to be designed for a wind force up to, and including 6 and significant wave heights up to, and including, 2 m.

D: A watercraft given design category D is considered to be designed for a wind force up to, and including 4 and significant wave heights up to, and including, 0,3 m, with occasional waves of 0,5 m maximum height.

The significant wave height is considered to be the primary factor for determining design category. Other parameters (e.g. meteorological) are descriptions of when these wave heights may be expected to occur. Refer to page 1-11 for weather information.

NOTICE

Your 230 Outrage is design category C

WARNING

It is imperative that you follow the recommendations listed on your capacity plate regarding the maximum amount of weight the boat can safely carry.

Power Capacity

The “Specifications & Dimensions” list on the following page indicates the maximum rated power listed for your boat. **DO NOT EXCEED THIS RATING.** The various engine types offered today are more powerful and require constant maintenance to stay at optimal performance. It is required of the operator to read all information regarding safety features, warning notices and maintenance schedules for continued safe operation of the engine.

The engine on the 230 Outrage has been tested and proven to be best suited for general use under normal conditions and load.

If you are re-powering your Boston Whaler®, you should pay particular attention to the maximum/minimum horsepower and maximum safe engine weight load your Boston Whaler® boat is rated for. There is a maximum engine weight label located port of the control console (See Figure 1.20.1).

NOTICE

The 230 Outrage is designed for a **MAXIMUM** outboard engine weight of 910 LBS (413 kg).

WARNING

- **DO NOT** Exceed the maximum engine power rating stated on the certification plate.
- Use caution while accelerating. Make sure passengers are safely seated in designated areas of the boat and all gear is stowed securely.

NOTICE

Always adjust the speed and direction of the craft to the varying sea conditions.

Section 2 • General Information

Dimensions & Clearances

Fig. 2.4.1

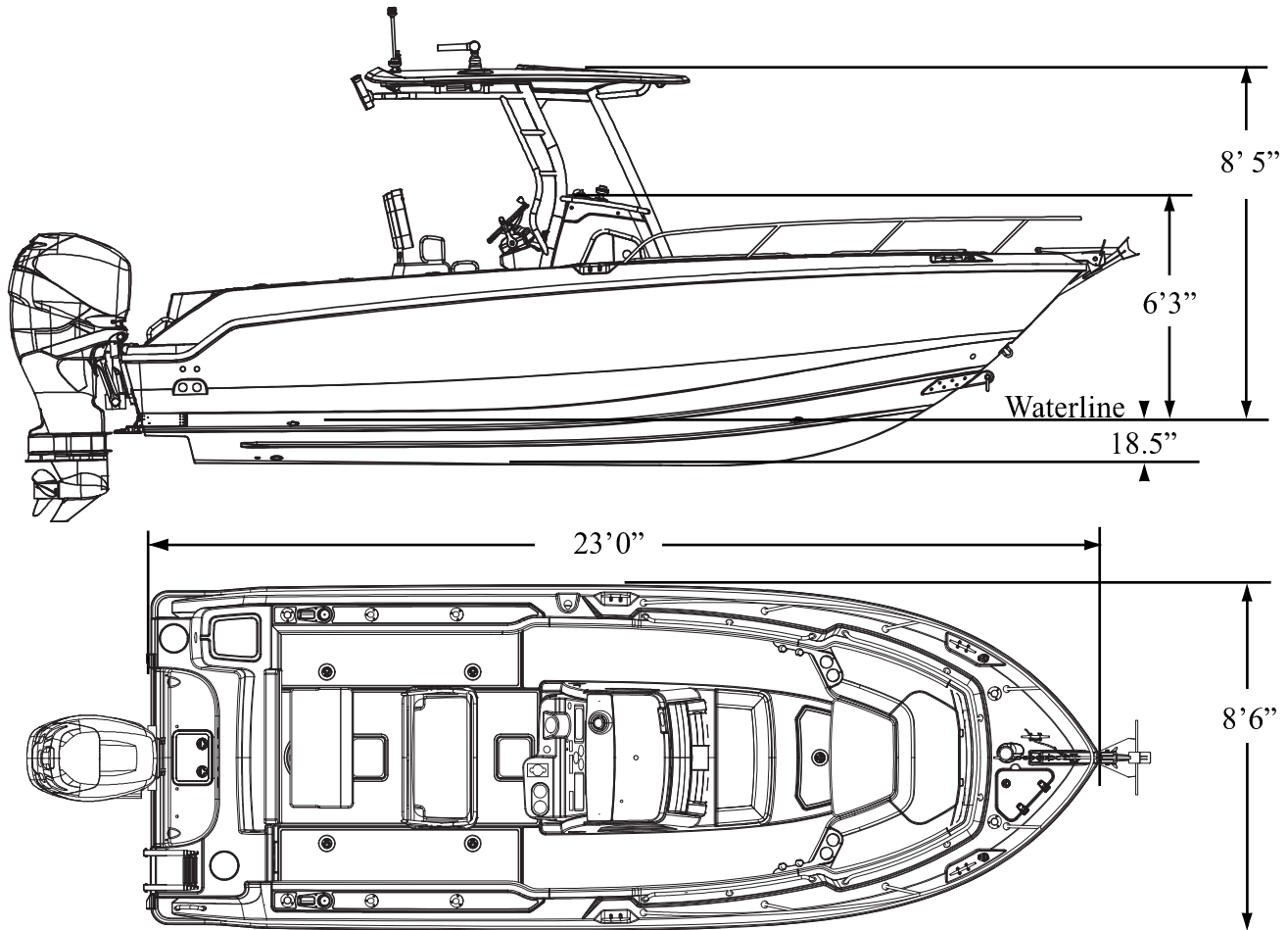

Specifications & Dimensions

(Specified measurements are approximations and are subject to variance.)

Overall Length	23' 0"	7 m	Maximum Engine Weight	910 lbs.	413 kg
Bridge Clearance	6' 3"	1.91 m	Maximum Weight, (passengers, engine(s), gear ³)	3,100 lbs	1,400 kg
Bridge Clearance (T-Top)	8' 5"	2.57 m	Persons	10	
Beam	8' 6"	2.59 m	Maximum Horsepower	400 HP	299 kw
Draft, (Hull only) ²	18.5"	.47 m	Minimum Horsepower	225 HP	168 kw
Weight (dry, no engine)	3800 lbs.	1,724 kg	Fuel Capacity	110 gal.	416 L
Weight (fuel, water, engine)	5548 lbs.	2516 kg	Water Capacity	20 gal.	76 L
Swamped Capacity	2980 lbs	1,352 kg			

¹ This is an approximate measurement. The true height of your boat on your trailer is dependant on a number of variables (i.e. bunk adjustment, bunk padding, tire pressure, etc.)

² Optional equipment and loading of the boat will affect the draft measurements. Follow the recommendations listed on your capacity plate regarding the maximum amount of weight your boat can safely carry.

³ Exceeding this weight will affect the boat's performance. **DO NOT** Exceed the weight listed on the capacity plate.

Passenger Areas

Deck Occupancy
Fig. 2.5.1

Working deck



This area is intended for occupation **ONLY** while mooring, anchoring, loading/unloading or when the boat is at rest. **NEVER** operate the engine while loading or unloading swimmers/divers from the swim platform/ladder.

Accommodation deck



This area of the boat is inside the cockpit and includes helm seating. Movement in this area should be done with extreme caution while the boat is underway. A sudden shift in boat direction can cause a loss of balance and lead to injury or death.

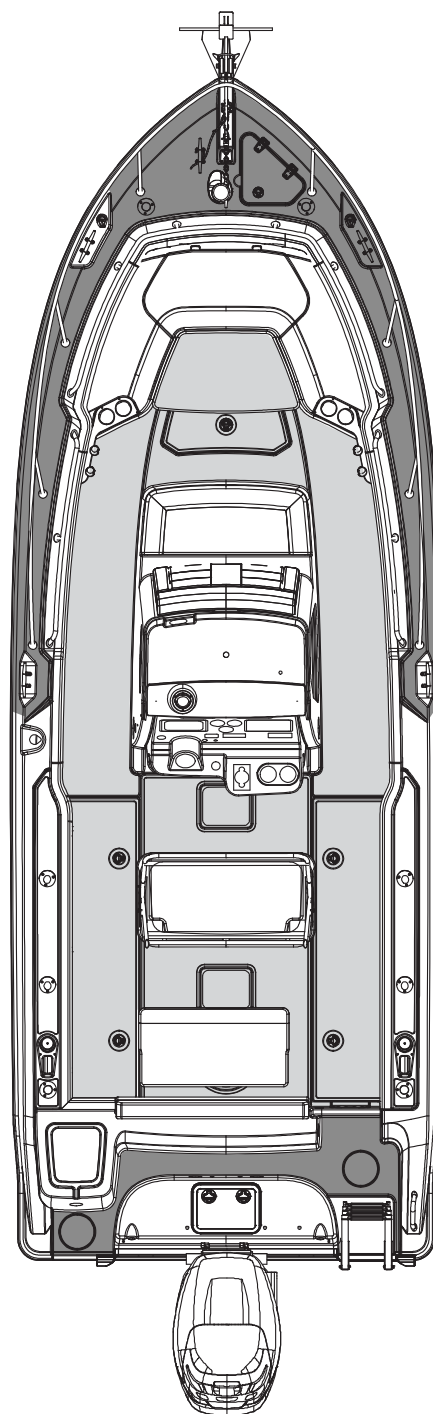

⚠ DANGER

Be aware of your footing while the boat is underway, slipping or falling could result in serious injury or death, especially if the boat is in motion or in rough seas. Keep the accommodation deck clean, so if movement is necessary it will be free of obstruction.

⚠ WARNING

- **Gelcoat surfaces are slippery when wet. Use extreme caution when walking on wet surfaces.**
- **Never occupy the working decks while the boat is underway.**
- **Use care when waxing to ensure that walkways are not made dangerously slippery.**

Recommended Passenger Locations

Recommended Seating & On-Plane Locations
Fig. 2.6.1

⚠ WARNING
NEVER allow passengers to ride in an area (i.e. bow, gunnels, transom, etc.) that will pose a hazard to themselves or the boat.

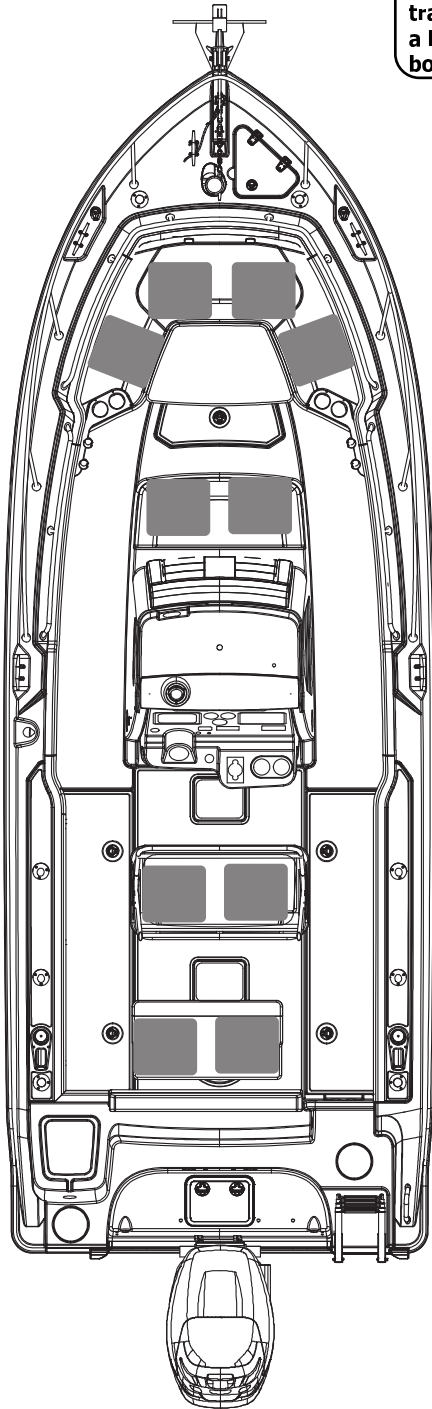

RECOMMENDED SEATING
while moored, at idle or at speed under 5 mph

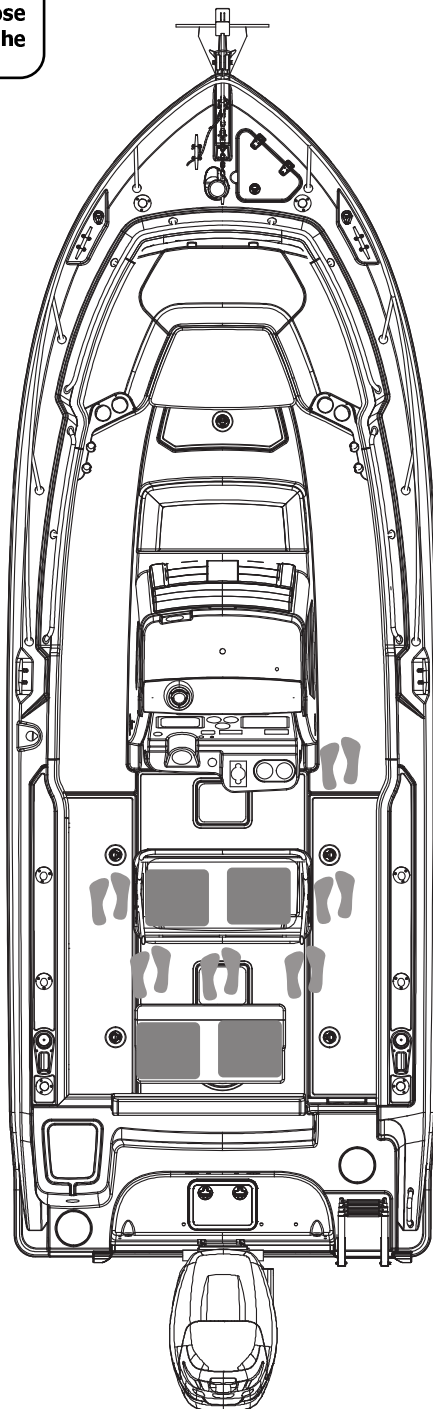

RECOMMENDED ON-PLANE
LOCATIONS

Section 2 • General Information

Location of Thru-Hull Fittings

Through Hull Fittings
Fig. 2.7.1

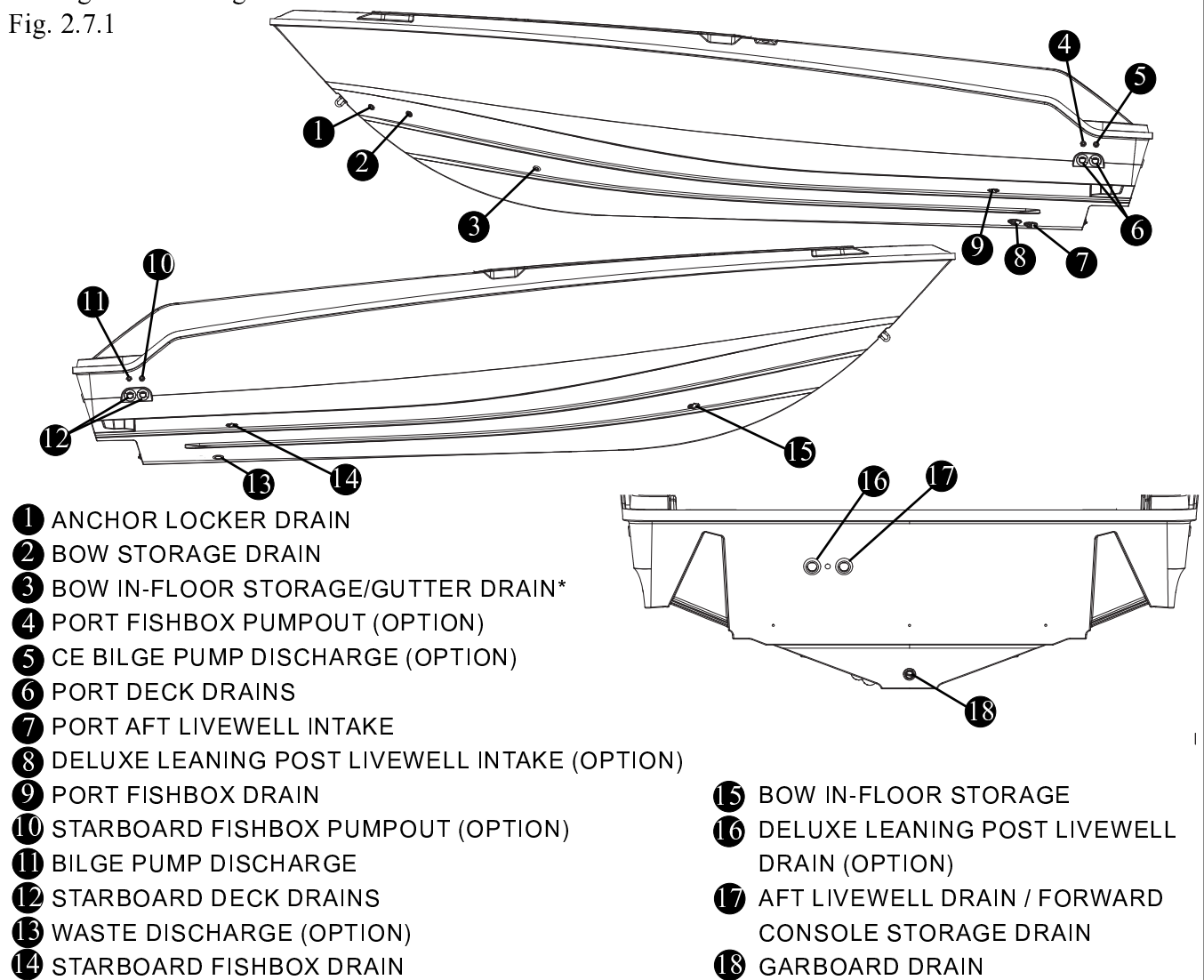

*See page 3-15

NOTICE

- The deck drains provide self-bailing capabilities while the boat is static in the water and no passengers on board. This feature prevents the accumulation of water in the cockpit.
- Depending on the type of boat you have, you may have underwater fittings that need drain plugs. Garboard drain plugs and fishbox drain plugs need to be in place before the boat goes into the water. Any fitting that will be underwater needs to be plugged or the seacock needs to be closed.
- Through hull fittings and deck drain scupper flaps should be checked for proper seal annually. When the boat is in the water the underwater fittings can be checked for dripping. It is recommended that the underwater fittings be removed, cleaned and resealed every other year.
- If the through hull fittings need to be replaced, it is recommended that an authorized Boston Whaler® dealer perform this type of repair. Through hull fittings that are improperly installed can cause premature hull failure and may void the Boston Whaler® limited warranty.
- A standard 1" "Snap-Tite" style plug can be used to replace the drain plug(s) in your boat. It is recommended that you carry spare plugs to be used in the event that the drain plug(s) become lost or damaged.

Features

Features

Fig. 2.8.1

- ① ANCHOR
- ② ANCHOR CLEAT
- ③ STAINLESS STEEL LOW PROFILE RAIL (OPTION)
- ④ BOW ROD HOLDERS (P&S) (OPTION)
- ⑤ BOW NAVIGATION LIGHTS (P&S)
- ⑥ BOW CLEATS (P&S)
- ⑦ BOW SPEAKERS (P&S) (OPTION)
- ⑧ INTEGRATED BOW GRAB RAIL (P&S)
- ⑨ BOW CUSHIONS
- ⑩ CUPHOLDERS (P&S)
- ⑪ IN-FLOOR STORAGE
- ⑫ VERTICAL ROD HOLDERS
- ⑬ FORWARD CONSOLE CUSHION
- ⑭ HORN
- ⑮ SPRING LINE CLEATS (8" P&S)
- ⑯ CONSOLE
- ⑰ FUEL FILL DECK PLATE
- ⑱ PORT FISHBOX W/DRAIN
- ⑲ GUNNEL MOUNTED ROD HOLDERS (P&S)
- ⑳ HELM SEATING W/ FLIP-UP BOLSTER AND BACKREST
- ㉑ HAWSE PIPE W/CUPHOLDER (P&S)
- ㉒ AFT LIVEWELL
- ㉓ FOLD AWAY AFT BENCH SEAT
- ㉔ MOTOREWELL DECK ACCESS
- ㉕ FOUR STROKE MERCURY ENGINE
- ㉖ AFT DECK ACCESS
- ㉗ RETRACTABLE SWIM LADDER
- ㉘ GRAB RAIL
- ㉙ FRESH WATER FILL DECK PLATE (OPTION)
- ㉚ TRANSOM DOOR W/ STAINLESS STEEL LATCH
- ㉛ DECK ACCESS
- ㉜ STARBOARD FISHBOX W/DRAIN
- ㉝ MAGNETIC COMPASS
- ㉞ BOW TABLE/BOW FILLER (OPTION)
- ㉟ BOW STORAGE (UNDER CUSHION)
- ㊱ WINDLASS (OPTION)
- ㊲ ANCHOR LOCKER

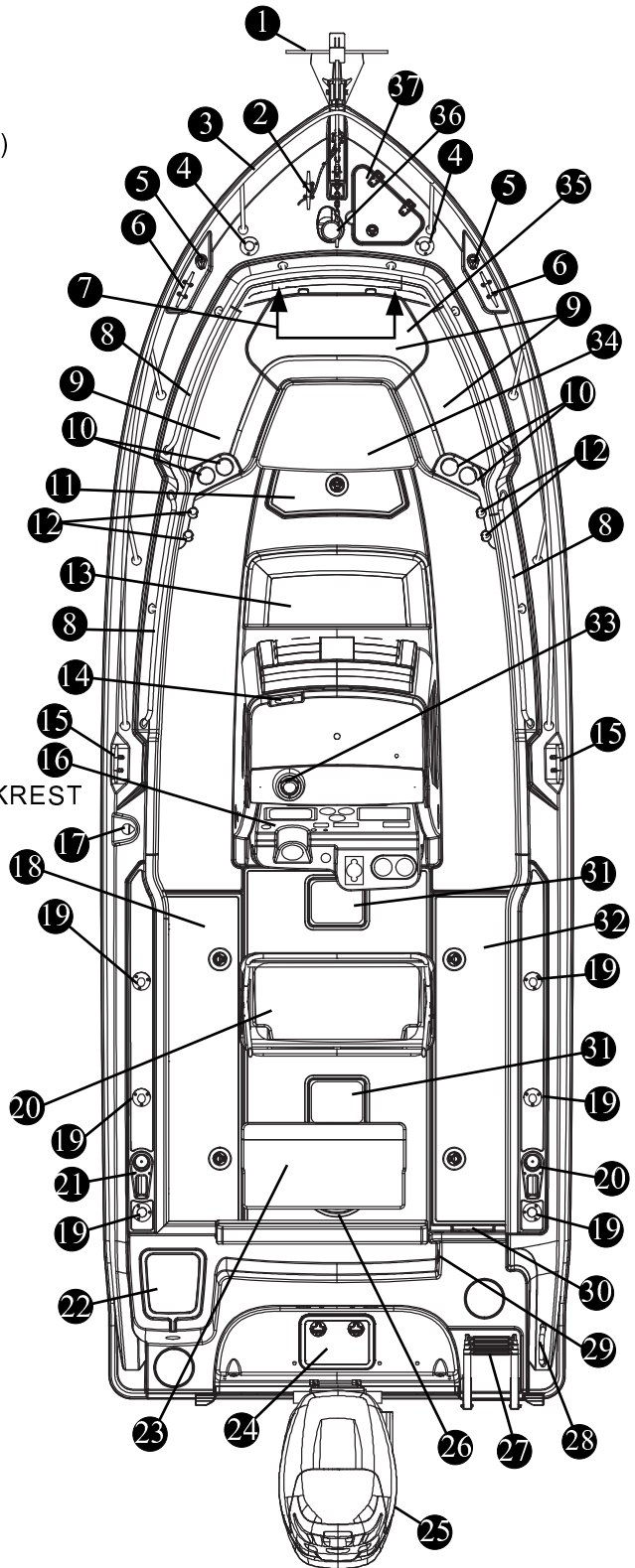

Section 2 • General Information

Console Features
Fig. 2.9.1

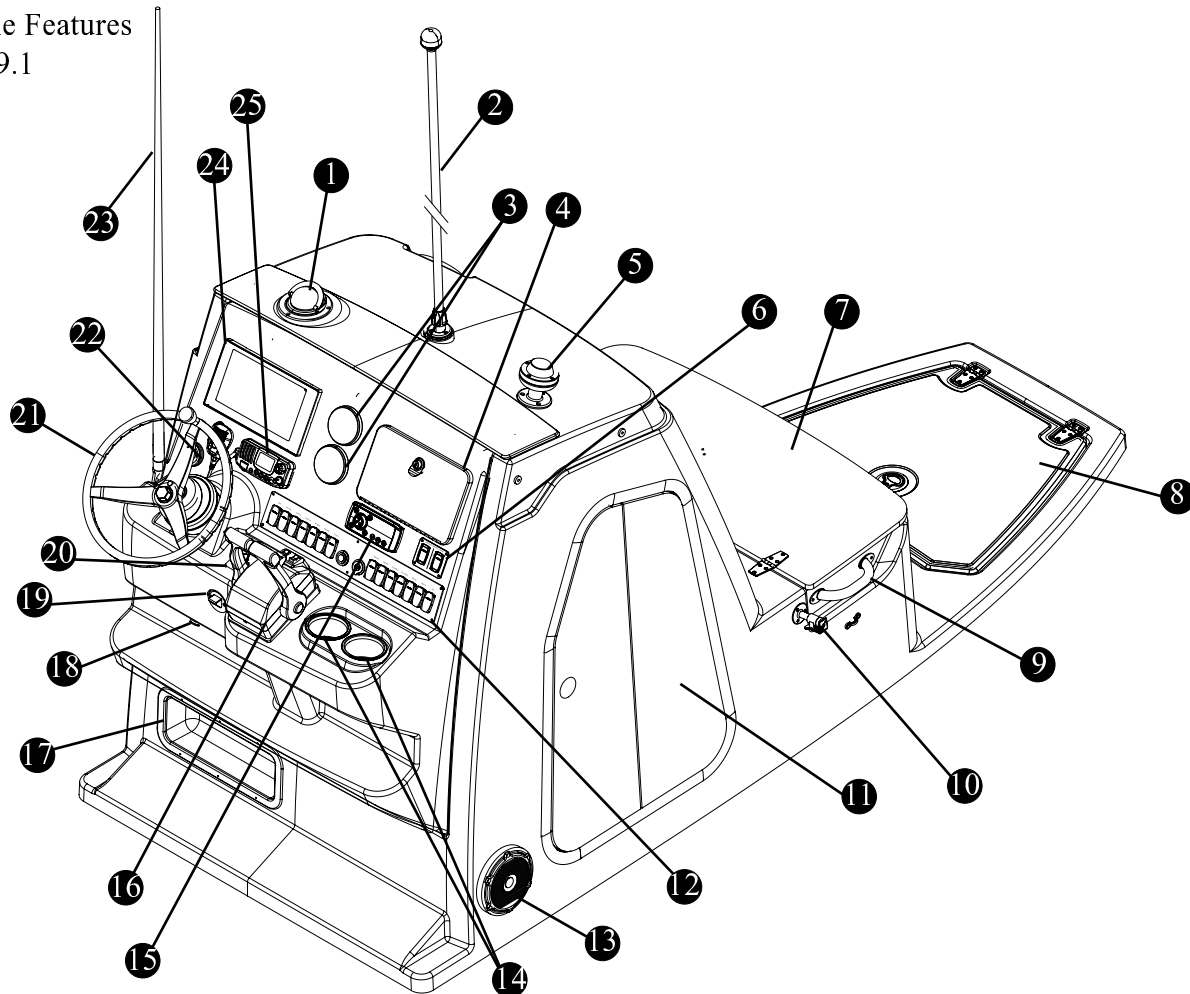

- | | |
|----------------------------------|--|
| ① MAGNETIC COMPASS | ⑭ CUPHOLDERS |
| ② ANCHOR LIGHT | ⑮ FUSION® STEREO (OPTION) |
| ③ SMARTCRAFT GAUGES | ⑯ THROTTLE/GEAR SHIFT |
| ④ GLOVE BOX W/USB INPUT (OPTION) | ⑰ FIRE EXTINGUISHER POCKET |
| ⑤ SATELLITE ANTENNA (OPTION) | ⑱ AMBIENT TEMPERATURE SENSOR |
| ⑥ WINDLASS REMOTE (OPTION) | ⑲ EMERGENCY ENGINE SHUT DOWN SWITCH |
| ⑦ FORWARD CONSOLE SEAT/STORAGE | ⑳ TRIM TAB CONTROL PAD W/INDICATORS |
| ⑧ IN-DECK STORAGE | ㉑ STAINLESS STEEL STEERING WHEEL W/KNOB |
| ⑨ GRAB RAIL (P&S) | ㉒ IGNITION SWITCH |
| ⑩ CONSOLE ACCESS DOOR LATCH | ㉓ VHF RADIO ANTENNA (OPTION) |
| ⑪ CONSOLE ACCESS DOOR | ㉔ RAYMARINE AXIOM PRO RVX 9" SCREEN
ELECTRONICS/NAVIGATION PACKAGE (OPTION) |
| ⑫ HELM SWITCH PANEL | ㉕ VHF RADIO |
| ⑬ STEREO SPEAKER (P&S) (OPTION) | |

Optional electronics availability:

Raymarine Axiom Pro RVX 9" screen electronics/navigation package (includes Chirp downvision sonar)

Section 2 • General Information

Helm Switch Panel

Fig. 2.10.1

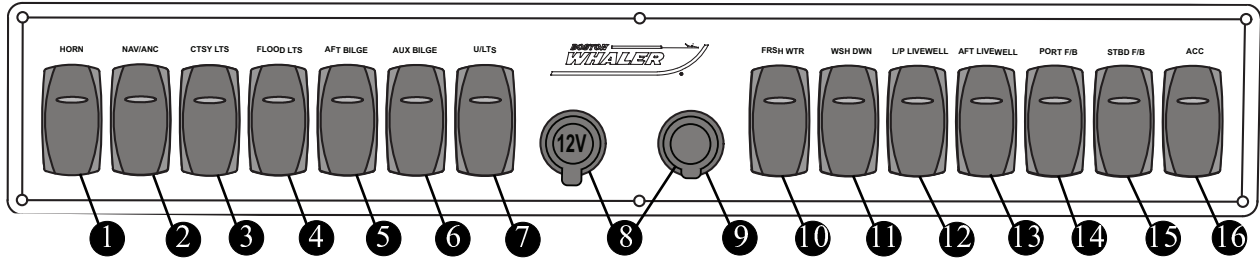

- | | |
|----------------------------------|--------------------------------------|
| ① HORN SWITCH | ⑨ USB INPUT (OPTION) |
| ② NAV/ANC LIGHTS | ⑩ FRESH WATER PUMP (OPTION) |
| ③ COURTESY LIGHTS | ⑪ RAW WATER PUMP |
| ④ FLOOD LIGHTS | ⑫ LEANING POST LIVEWELL (OPTION) |
| ⑤ AFT BILGE PUMP | ⑬ AFT LIVEWELL |
| ⑥ AUXILIARY BILGE PUMP (OPTION) | ⑭ PORT FISHBOX PUMPOUT (OPTION) |
| ⑦ UNDERWATER LIGHTS (OPTION) | ⑮ STARBOARD FISHBOX PUMPOUT (OPTION) |
| ⑧ 12V ACCESSORY INPUT (STANDARD) | ⑯ ACCESSORY |

Bilge Layout

Fig. 2.10.2

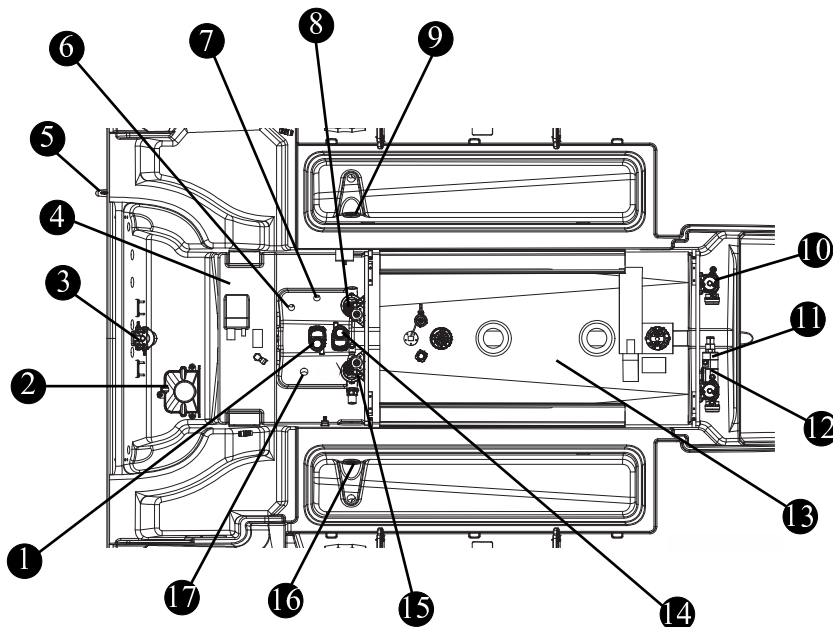

- | | |
|---|--|
| ① BILGE PUMP (1100 GPH/4164 LPH) (OPTION) | ⑪ MACERATOR (OPTION) |
| ② POWER STEERING PUMP | ⑫ FRESH WATER PUMP (OPTION) |
| ③ FUEL/WATER SEPARATOR | ⑬ 110 GAL (416 L) FUEL TANK |
| ④ 20 GAL (76 L) FRESH WATER TANK (OPTION) | ⑭ BILGE PUMP (1100 GPH/4164 LPH) |
| ⑤ TRANSDUCER (OPTION) | ⑮ STARBOARD FISHBOX PUMP (OPTION) |
| ⑥ AFT LIVEWELL INTAKE SEACOCK | ⑯ STARBOARD FISHBOX DRAIN (OPTION) |
| ⑦ L/P LIVEWELL/RAW WATER INTAKE (OPTION) | ⑰ WASTE OVERBOARD DISCHARGE SEACOCK (OPTION) |
| ⑧ PORT FISHBOX PUMP (OPTION) | |
| ⑨ PORT FISHBOX DRAIN (OPTION) | |
| ⑩ RAW WATER PUMP | |

Section 2 • General Information

Bow Features
Fig. 2.11.1

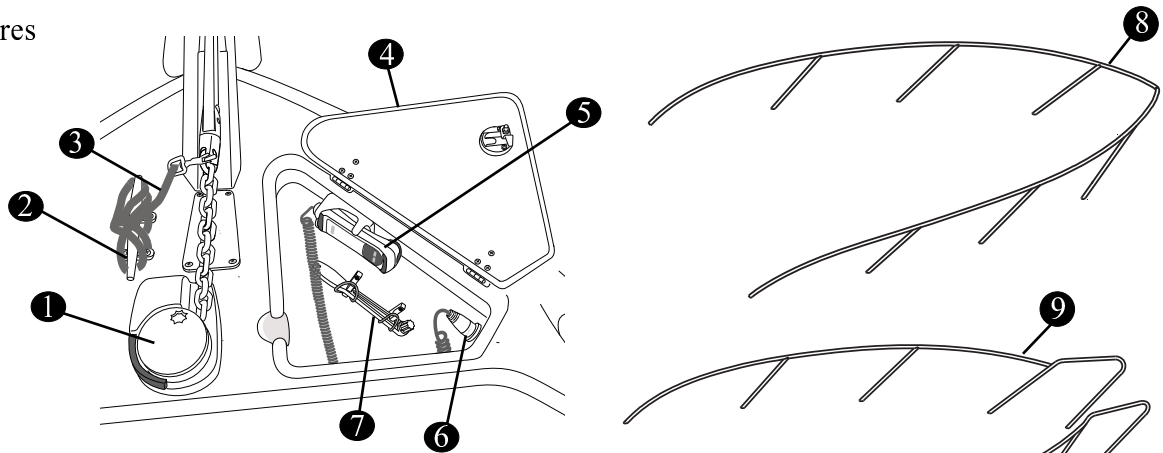

- ① WINDLASS W/RODE/STAINLESS STEEL ANCHOR (OPTION)
- ② ANCHOR CLEAT
- ③ SAFETY LANYARD
- ④ BOW HATCH
- ⑤ WINDLASS REMOTE (OPTION)
- ⑥ WINDLASS REMOTE POWER SOURCE (OPTION)
- ⑦ WINDLASS EMERGENCY HANDLE (OPTION)

- ⑧ BOW RAIL (OPTION)*
- ⑨ SPLIT BOW RAIL (OPTION)*

* Deletes standard forward rails

Cockpit/Transom Features
Fig. 2.11.2

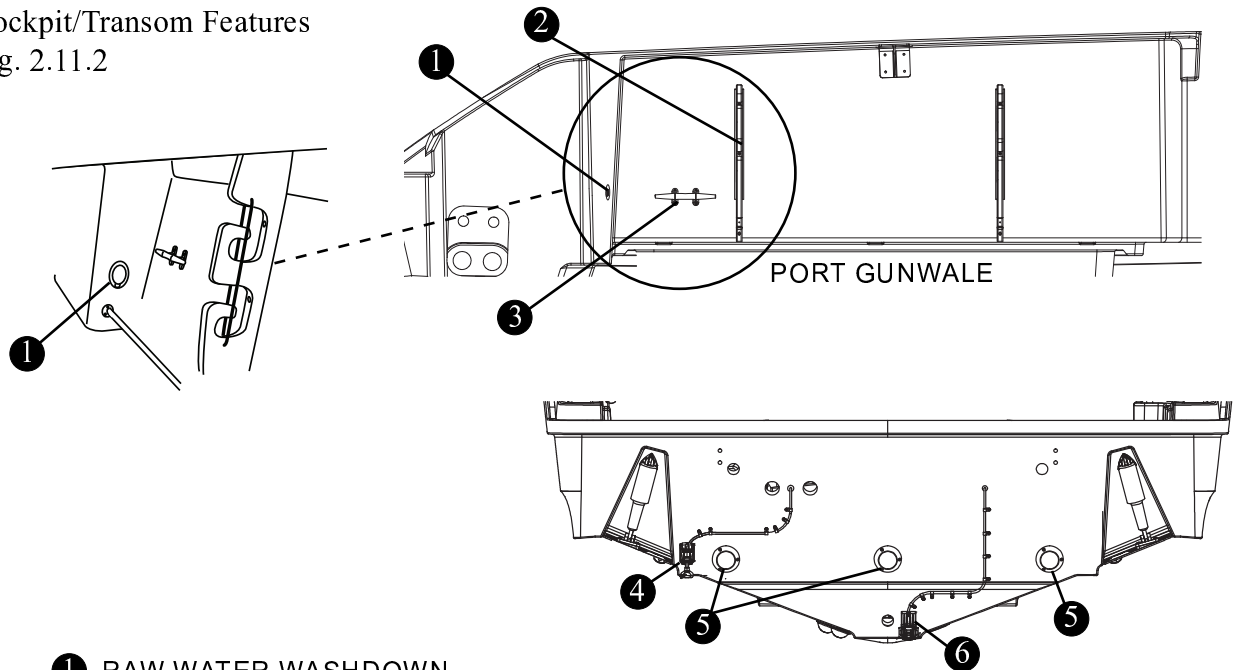

- ① RAW WATER WASHDOWN
- ② UNDER GUNWALE ROD STORAGE (P&S)
- ③ STERN CLEAT (2) (P&S)
- ④ TRANSDUCER (OPTION)
- ⑤ UNDERWATER LED LIGHTS (OPTION)
- ⑥ DEPTH FINDER/TRANSDUCER/SPEEDOMETER/TEMPERATURE GAUGE (OPTION)

Section 2 • General Information

Transom Features
Fig. 2.12.1

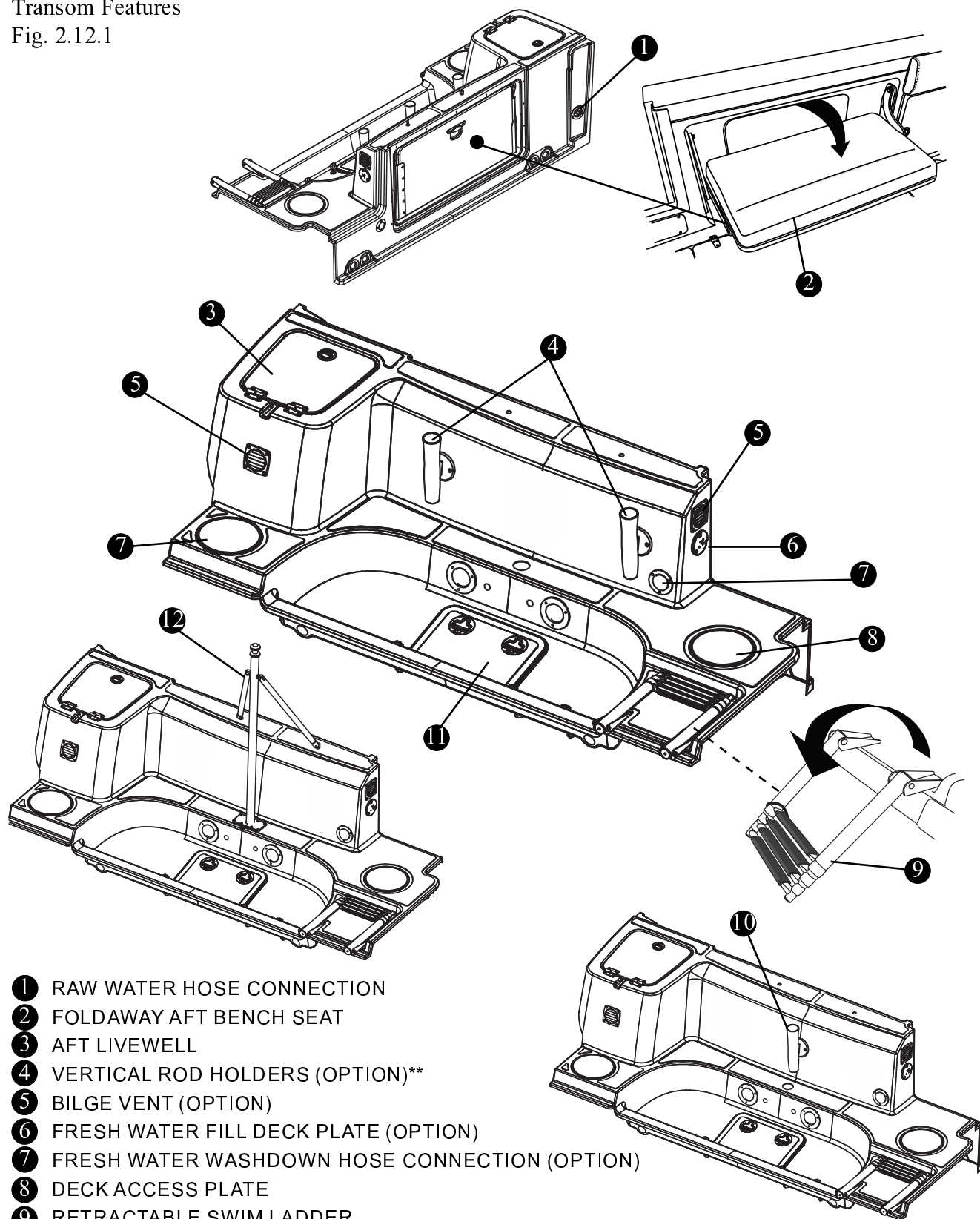

- ① RAW WATER HOSE CONNECTION
- ② FOLDAWAY AFT BENCH SEAT
- ③ AFT LIVEWELL
- ④ VERTICAL ROD HOLDERS (OPTION)**
- ⑤ BILGE VENT (OPTION)
- ⑥ FRESH WATER FILL DECK PLATE (OPTION)
- ⑦ FRESH WATER WASHDOWN HOSE CONNECTION (OPTION)
- ⑧ DECK ACCESS PLATE
- ⑨ RETRACTABLE SWIM LADDER
- ⑩ VERTICAL ROD HOLDER (OPTION)*
- ⑪ MOTORWELL ACCESS HATCH
- ⑫ SKI PYLON (OPTION)

* With dual engine option only
** Not available with ski pylon

Section 2 • General Information

Console Features (Interior)

Fig. 2.13.1

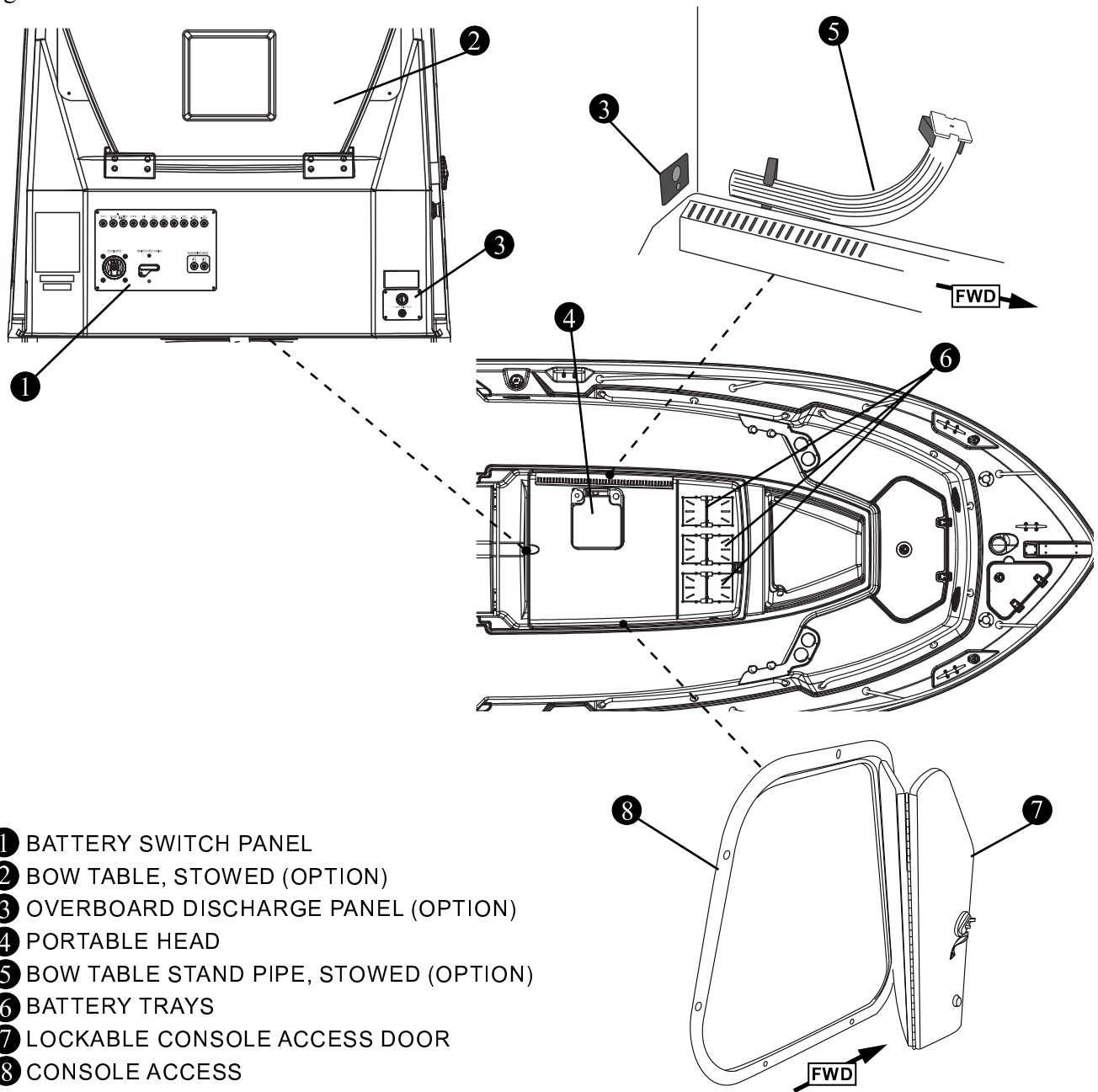

Section 2 • General Information

Leaning Post Features

Fig. 2.14.1

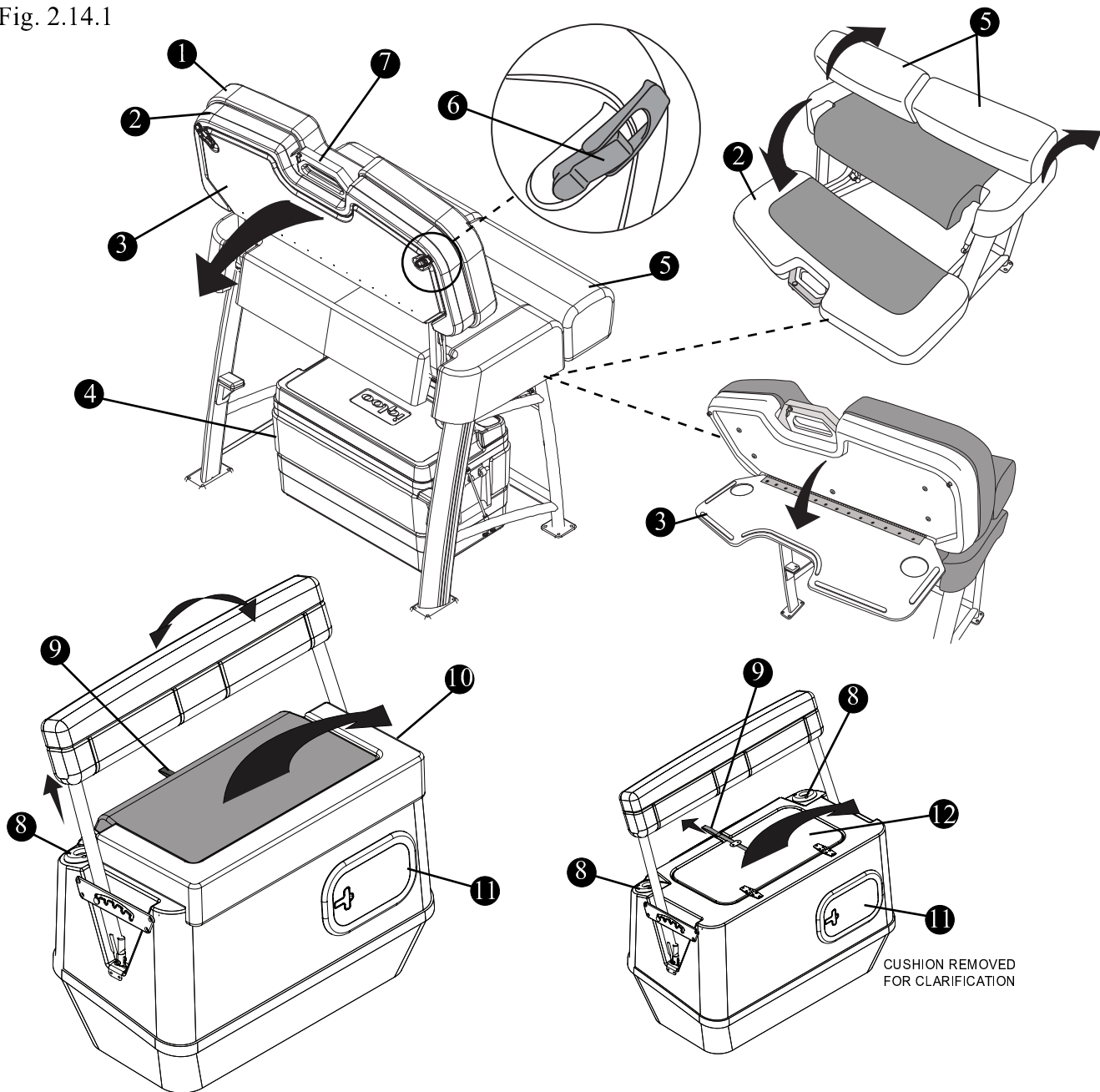

- ① HELM SEATING W/ FLIP-UP BOLSTER AND BACKREST
- ② FOLD DOWN REVERSE FACING BENCH SEAT
- ③ FOLD DOWN WORK SURFACE
- ④ 54 QT (51.3 L) COOLER
- ⑤ FLIP UP BOLSTERS
- ⑥ WORK SURFACE RELEASE LATCH (P&S)
- ⑦ BENCH SEAT RELEASE HANDLE W/LOCK (SEE PG. 3-15)
- ⑧ RODHOLDERS (P&S)
- ⑨ LIVEWELL COVER RELEASE STRAP
- ⑩ DELUXE LEANING POSTW/ 30 GAL (113.6 L) LIVEWELL (OPTION)
- ⑪ ACCESS HATCH
- ⑫ 30 GAL (113.6 L) LIVEWELL

Section 2 • General Information

Hardtop Features
Fig. 2.15.1

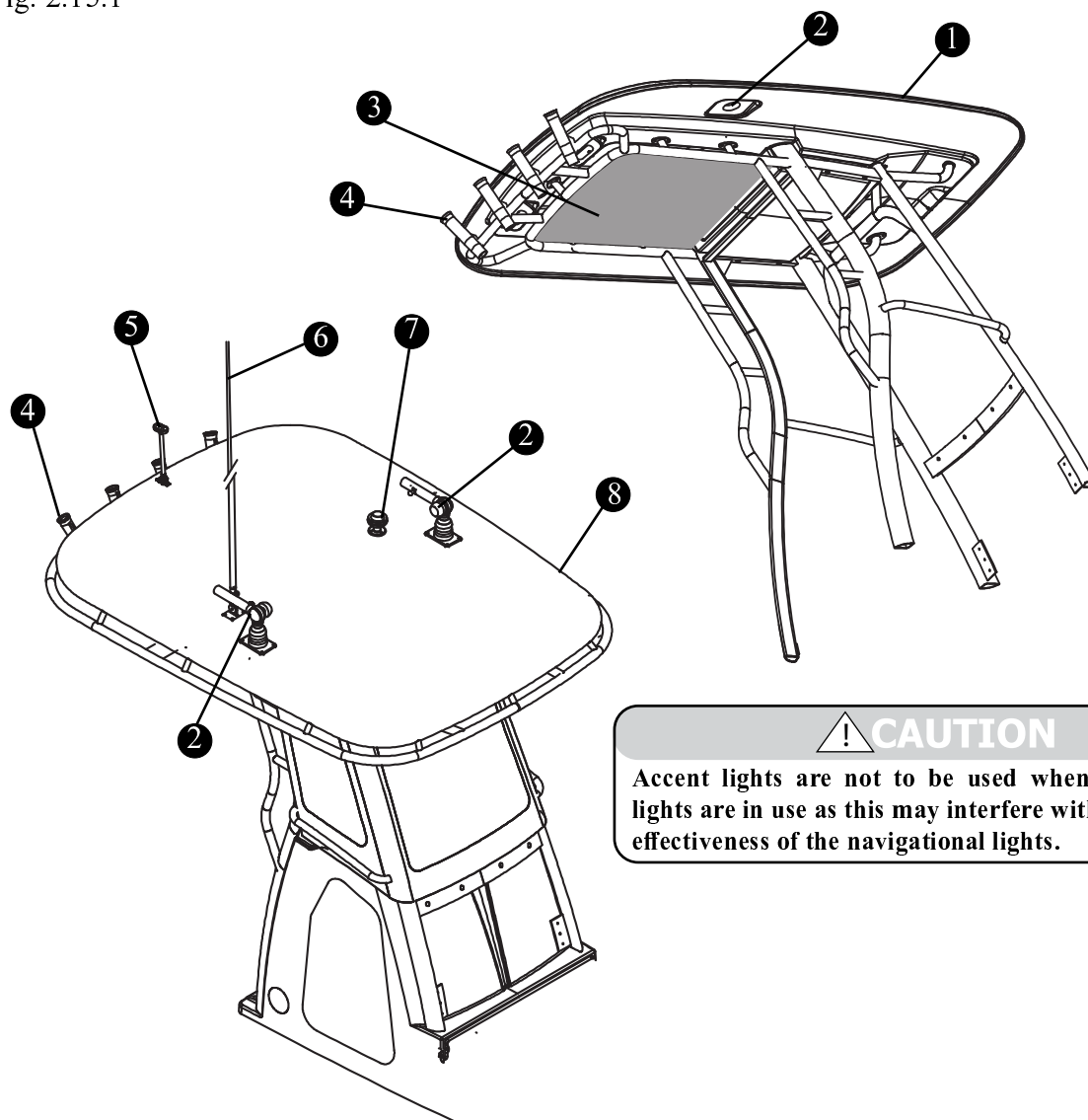

CAUTION

Accent lights are not to be used when navigational lights are in use as this may interfere with the effectiveness of the navigational lights.

- ① HARDTOP (OPTION)
- ② RADIAL OUTRIGGER (OPTION)
- ③ STORAGE BAG
- ④ RODHOLDERS (4)

- ⑤ ALL-ROUND (ANCHOR) LIGHT
- ⑥ VHF RADIO ANTENNA (OPTION)
- ⑦ SIRIUS® SATELLITE ANTENNA (OPTION)
- ⑧ T-TOP (OPTION)

Seating
Fig. 2.16.1

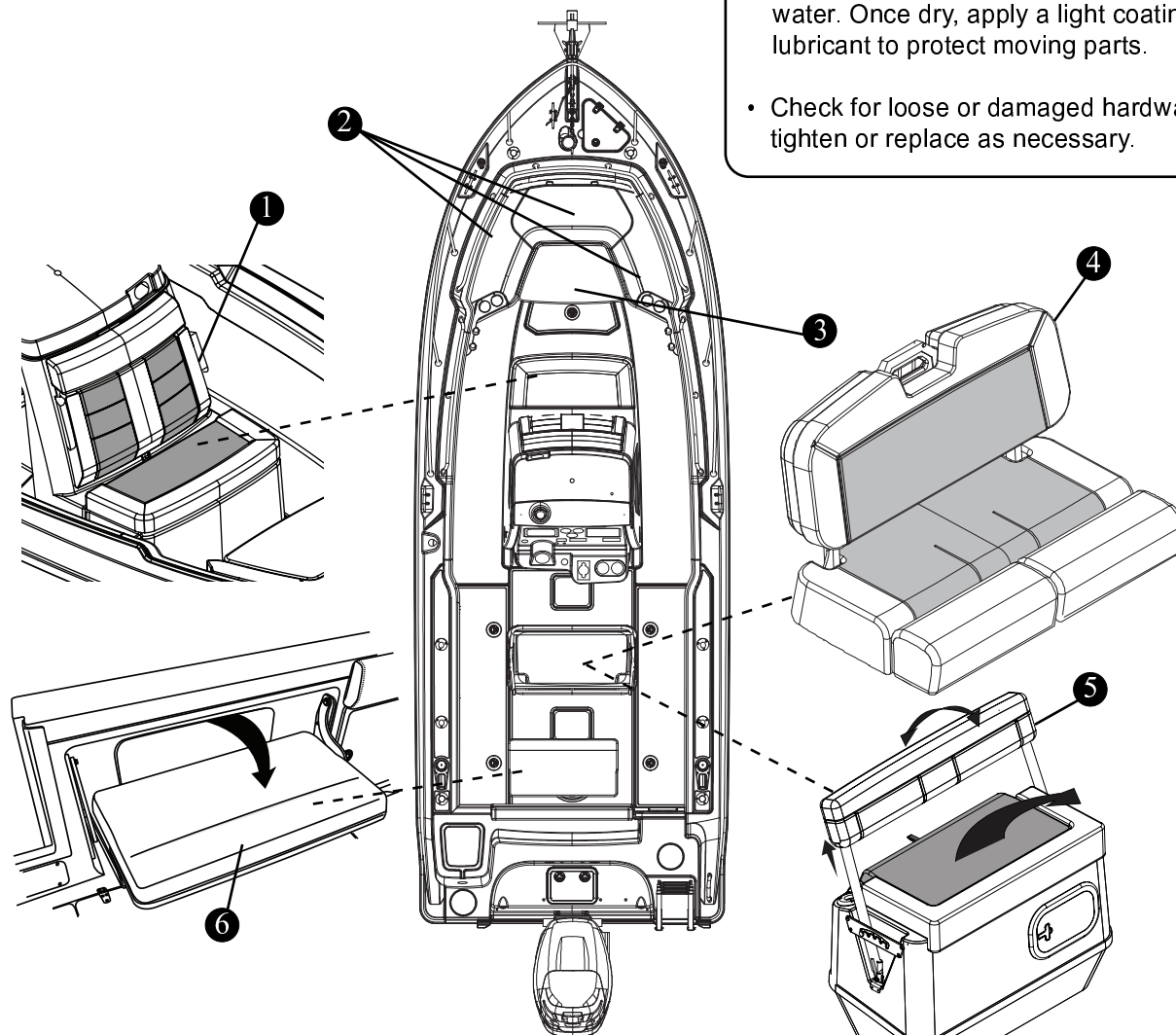

NOTICE

SEAT MAINTENANCE

- Always wash metallic parts with soap and water and rinse thoroughly with fresh water. Once dry, apply a light coating of lubricant to protect moving parts.
- Check for loose or damaged hardware and tighten or replace as necessary.

- ① FORWARD CONSOLE SEAT W/BACKREST AND STORAGE UNDER
- ② BOW SEATING CUSHIONS
- ③ BOW FILLER CUSHION (OPTION)
- ④ HELM SEATING W/ FLIP-UP BOLSTER AND BACKREST
- ⑤ DELUXE LEANING POST W/30 GAL (113.6 L) (OPTION)
- ⑥ FOLDAWAY AFT BENCH

SmartCraft™ VesselView

VesselView allows the boat operator to receive a wealth of critical operational information, displayed clearly and instantly at the helm on the LCD display. The system continuously monitors and reports information ranging from basic operating data to detailed vessel environment information.

If integrated with the optional Raymarine navigation system, the SmartCraft® VesselView will display up to the minute course, speed, and fuel-to-destination information.

The vessel view display will activate when the master key switches, inside the console, are turned on.

SmartCraft® VesselView

Fig. 2.17.1

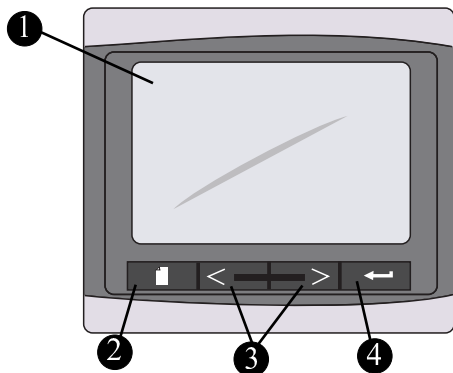

- ① DISPLAY SCREEN
- ② MENU BUTTON
- ③ DATA NAVIGATION BUTTONS
- ④ ENTER BUTTON

The SmartCraft™ system and GPS antenna are interfaced to only one of the Raymarine displays in the network. This is the “master” unit. If equipped, the additional unit is the “slave” unit. The “master” unit must be turned ON in order to transmit data to the “slave” unit. In such a case as the “master” unit is unavailable, the “slave” can be easily converted to a “master”.

System Calibration (For First Time Use)

Boston Whaler® or your Boston Whaler® dealer has calibrated the Smartcraft™ VesselView to the equipment on your boat. If equipment is added, the system will need to be recalibrated.

FOR RECALIBRATION OR MANUFACTURERS INFORMATION REGARDING THE SMARTCRAFT™ SYSTEM VIEW REFER TO THE MANUFACTURER'S OWNER'S MANUAL FOUND IN YOUR OWNER'S PACKET.

SmartCraft™ VesselView MOBILE

VesselView MOBILE connects the SmartCraft™ data network to your iPhone or android mobile device via Bluetooth Low Energy4.0(BLE). With VesselView MOBILE you have the power of SmartCraft™ on your mobile device with all the

digital data your SmartCraft™ engine supports plus new features such as:

- Maintenance reminders
- Mapping
- Performance summary
- Fault code diagnostics

Digital Throttle/Shift (DTS®)

The 230 Outrage is equipped with a state of the art “drive-by-wire” gear shift and throttle control system. The Digital Throttle/Shift (DTS®) is the latest technology in recreational boating. Located on the console, starboard of the helm (See figure 2.9.2). The gear shift/throttle control unit controls both the shifting mechanism and throttle.

Digital Throttle/Shift (DTS®)

Fig. 2.17.2

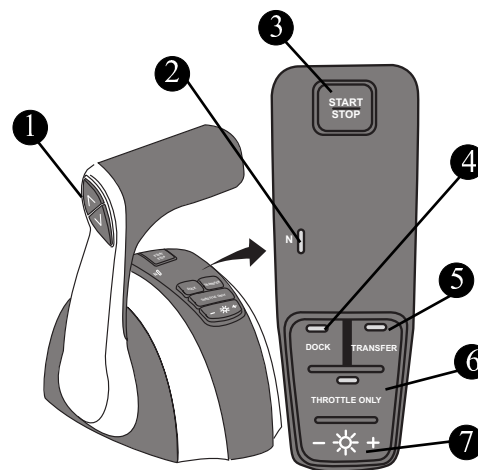

- ① TRIM/TILT CONTROL SWITCH
- ② NEUTRAL INDICATOR LIGHT
- ③ START/STOP
- ④ DOCK MODE
- ⑤ TRANSFER SWITCH
- ⑥ THROTTLE ONLY
- ⑦ BACKLIGHT DIMMING CONTROL

The throttle control regulates the RPM of the engine. Regulating the RPM of the engine will control the speed of the boat. Moving the lever forward engages the forward gear. Continuing to move the lever forward will increase the forward speed of the boat.

Likewise, to reverse power, bring the control lever back to engage the reverse gear and increase the reverse thrust by continuing to pull back on the throttle control.

The control must be in the “NEUTRAL” position to start your engine. Neutral is the most central position of the control unit and acts as an idle (you will hear and feel a click when neutral is engaged). While in this position, the propeller is not rotating.

There is a “THROTTLE ONLY” button on the throttle control that when depressed will disengage the shifting mechanism and will allow you to operate the throttle without engaging the propeller. The button will automatically engage the shifting mechanism once the throttle control has been moved back to its center position.

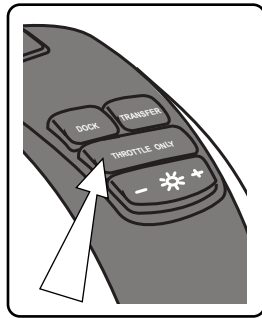

CAUTION

Shift controls into NEUTRAL before starting engine. Shift only when engine is at idle. Reversing at high speeds can cause flooding/swamping due to water being pushed over the transom.

NOTICE

Wind and sea currents can change how your boat responds while in motion. Understanding your boat and its reactions at speed will make boating safer and more enjoyable.

REFER TO THE ENGINE MANUFACTURER'S MANUAL IN YOUR OWNER'S MANUAL PACKET FOR COMPLETE INSTRUCTIONS, INFORMATION AND WARRANTY.

Power Trim

ATTENTION

Ensure continuous visibility of other boats, swimmers and obstacles during bow-up transition to planing. Adjust engine to an intermediate trim as soon as boat is on plane.

The power trim & tilt system located on the shift control lever (Fig. 2.19.1) allows you to raise and lower the engine to achieve optimum performance and is used for trailering, launching and beaching.

Operation

The engine trim is controlled by a momentary rocker switch, where constant pressure must be applied to the switch during the raising and lowering cycles. Use the power trim switch to obtain ideal boat angle (in relation to the water surface) for a given load and water condition. In most cases the best all-round performance is obtained when the boat runs at an angle between a 3 to 5 degrees.

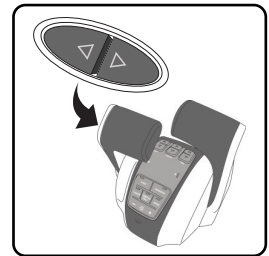

REFER TO THE ENGINE MANUFACTURER'S MANUAL IN YOUR OWNER'S MANUAL PACKET FOR COMPLETE INSTRUCTIONS AND WARRANTY INFORMATION.

Dual Engine Gear Shift/Throttle (Option)

If equipped, dual engines are controlled by the dual gear shift/throttle unit located on the control console (See fig. 2.9.2).

Both of the control arms must be in the neutral position in order to start your engines. Neutral is the most upright position of the control unit and acts as an idle. While in the neutral position, the propeller will not be rotating.

Throttle Only

When depressed, the throttle only button located on the control pad (Figure 2.19.1) will disengage the shift mechanism and allow you to operate the throttle without engaging the propeller. This feature allows you to warm up the engines prior to making way.

Dual Engine Throttle (Option)

Fig. 2.19.1

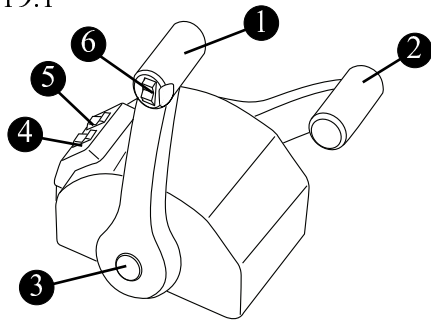

- ① PORT ENGINE THROTTLE/SHIFT CONTROL LEVER
- ② STARBOARD ENGINE THROTTLE/SHIFT CONTROL LEVER
- ③ THROTTLE ONLY BUTTON*
- ④ PORT ENGINE POWER TRIM SWITCH
- ⑤ STARBOARD ENGINE POWER TRIM SWITCH
- ⑥ DUAL ENGINE POWER TRIM SWITCH

* Port button shown, starboard is typical

The button will automatically engage the shift mechanism once the throttle is returned to the center (neutral) position. You will hear and feel a “click” when it engages.

Power Trim Operation

The power trim & tilt system allows you to raise and lower the engine(s) for optimum performance in the water and for trailering, launching and beaching. The switches are momentary, which means that constant pressure must be applied to the switch(es) during the raising and lowering cycle.

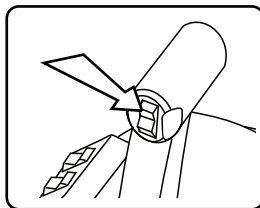

Use the trim switches to obtain an ideal boat angle (in relation to the water surface) for a given load and water condition.

In most cases, best all-round performance is obtained with the engine adjusted so that the boat will run at a 3° to 5° angle to the water.

REFER TO THE ENGINE MANUFACTURER'S MANUAL IN YOUR OWNER'S MANUAL PACKET FOR COMPLETE INSTRUCTIONS, INFORMATION AND WARRANTY.

Navigation Lighting

NOTICE

Regulations state that all boats, no matter the size, must display navigation lights.

Your boat comes equipped with navigation lighting for your safety. Regulations state that all boats must display navigation lights between sunset and sunrise and during periods of restricted visibility, such as rain, fog, haze, etc. If operating in reduced visibility or between sunset and sunrise it is necessary to maintain a safe speed and post a lookout.

It is the responsibility of the operator to ensure that the navigation lights are in good working order and that the proper lighting is shown and not obstructed in its intended arc of visibility. This vessel's navigation lights may include an expiration date on the housing. If one is located, replace light before expiration date, even if light is functional, as lighting quality may be compromised.

Do not add lights that interfere with required navigation lights. Some lights, such as blue colored lights, may be illegal to display on a boat. It is the owner's responsibility to ensure that displayed lights are also compliant with local regulations.

Operating the Navigation Lighting

A three-position switch, located on the console switch panel marked “NAV/ANC” (See figure 2.20.2) controls the navigation and anchor lighting.

In the “Navigation Lights” position the port (red), starboard (green) and all around (white) lights will illuminate. These lights let other vessels know the approximate size and direction of travel of your boat, depending on which lights they can see. In the “Anchor Lights” position, the white, 360°, all around light will illuminate, showing other boaters your location while at anchor.

Section 2 • General Information

Navigation/Anchor Lighting
Fig. 2.20.1

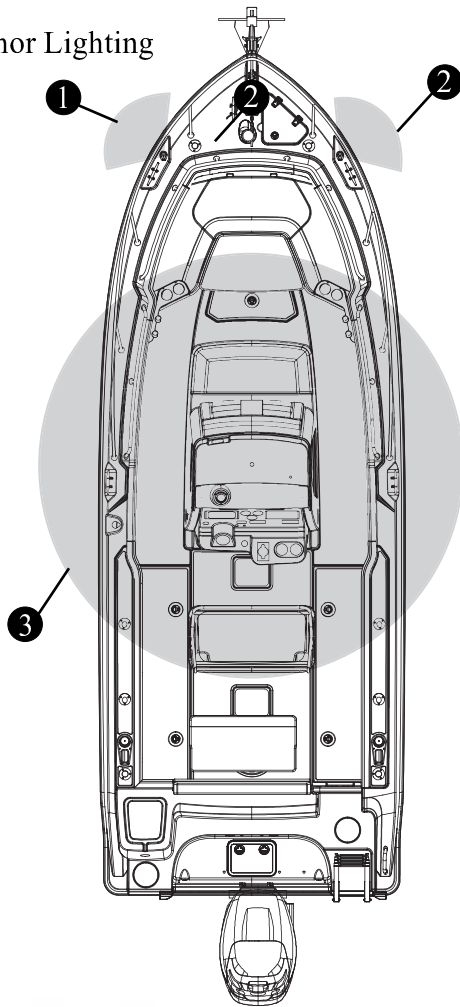

STANDARD BOAT

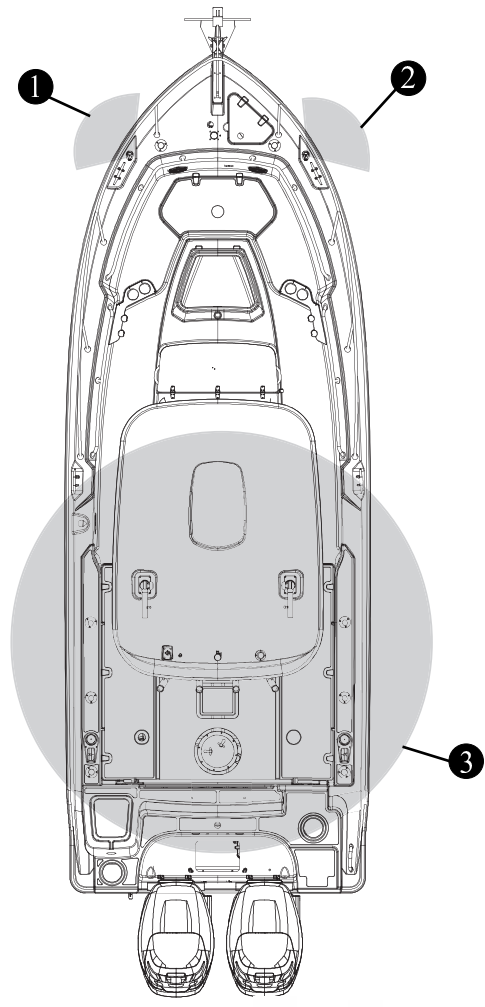

HARDTOP OPTION

- ① 112.5° PORT NAV LIGHT (RED) VISIBLE 1 NM
- ② 112.5° STARBOARD NAV LIGHT (GREEN) VISIBLE 1 NM
- ③ 360° ALL ROUND LIGHT (WHITE) VISIBLE 2 NM



CAUTION

Accent lights are not to be used when navigational lights are in use as this may interfere with the effectiveness of the navigational lights.

NAV/ANC Switch
Fig. 2.20.2

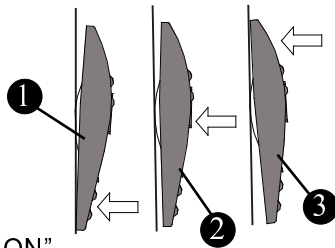

- ① "OFF"
- ② ANCHOR LIGHT "ON"
- ③ NAVIGATIONAL LIGHTS "ON"

NOTICE

The improper sequence of navigation lighting may be as dangerous as no lighting at all.

Trim tabs

ATTENTION

Visibility from the helm station may be limited, use of trim tabs may be necessary to maintain adequate visibility in some running conditions. Avoid serious injury or death from collisions. maintain a lookout as required by USCG Navigation Rules.

Your vessel may be equipped with electrically powered trim tabs (Fig. 2.21.1). If installed, the trim tabs are located on the bottom of the hull at the transom and are used to assist in leveling your vessel caused by uneven weight distribution or strong cross winds. The use of trim tabs may also increase your operator visibility, particularly during initial acceleration.

An untrimmed boat will:

- Reduce fuel economy
- Increase wear on your engine.

Operation

The trim tabs are controlled by rocker switches located at the helm console. Short momentary bursts of the rockers will achieve proper attitude of the hull. The trim tab switch is marked “bow up” and “bow down”.

Using the trim tabs will:

- Level the boat; fore and aft, port and starboard.
- Reduce resistance in the steering system.
- Increase speed
- Reduce strain on the engines
- Provide a smoother, more stable ride

Maintenance

The trim tabs are sealed, waterproof and maintenance free. General cleaning is recommended, and marine growth should be removed when the boat is out of the water. Also inspect the sacrificial anodes regularly and replace as necessary, refer to chapter 5 for additional information.

Electrically Powered Trim Tabs

Fig. 2.21.1

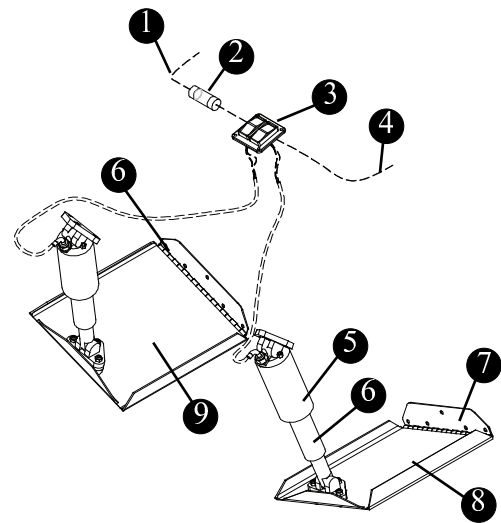

- ① POSITIVE WIRE
- ② 20 AMP BREAKER*
- ③ TRIM TAB SWITCH
- ④ NEGATIVE WIRE
- ⑤ LOW VOLTAGE ELECTRIC MOTOR
- ⑥ STAINLESS STEEL RAM
- ⑦ STAINLESS STEEL HINGE
- ⑧ STARBOARD TRIM TAB PLATE
- ⑨ PORT TRIM TAB PLATE

* LOCATED ON MAIN BREAKER

Trim Tab switch w/indicators

Fig. 2.21.2

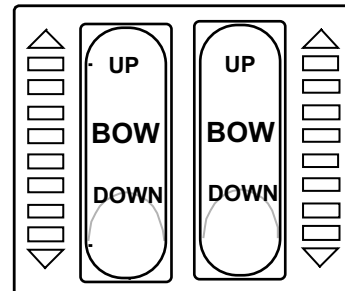

REFER TO THE MANUFACTURER'S MANUAL IN YOUR OWNER'S MANUAL PACKET FOR COMPLETE INSTRUCTIONS AND WARRANTY.

Active Trim (Option)

Active Trim provides the benefit of perfect trimming without constantly monitoring and adjusting trim with changes to boat speed or when going into turns.

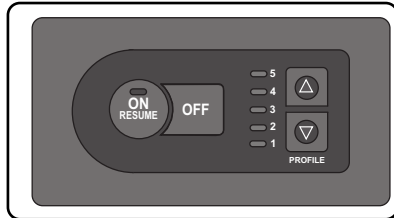

Active Trim controls the trim in accordance with boat speed and engine rpm. This avoids potential problems such as engines trimming up (instead of down) if the propeller breaks loose in a hard turn. It also avoids issues with the engine trimming up too early or too late when the boat is getting on plane.

Active Trim has five selectable trim profiles that accommodate nearly any boat application. These profiles allow operators to compensate for changes in boat load, operator preference and weather conditions, while maintaining full auto operation. REFER TO THE MANUFACTURER'S MANUAL IN YOUR OWNER'S PACKET FOR COMPLETE INSTRUCTIONS AND WARRANTY.

Canvas (Option)

The optional canvas will keep its appearance and maintain proper working order provided you follow a few simple steps for cleaning and maintenance (See "Canvas Care & Maintenance", section 5 of this manual).

Optional canvas for your 230 Outrage includes:

- Console cover
- Bow cushion cover
- Console seat and backrest cover
- Deluxe leaning post cover
- Stern seat backrest cover
- Sun-top with boot (black or blue)
- Weather curtain set (must select T-top or Hardtop)

NOTICE

Consult your Boston Whaler® dealer or check with your canvas owner's manual before using any chemical treatments on your canvas.

⚠ DANGER

Gasoline engines produce CARBON MONOXIDE. Prolonged exposure can cause serious injury or death. To reduce carbon monoxide accumulation, increase air flow by opening or adjusting the canvas to allow for more air circulation.

Canvas (Option)
Fig. 2.22.1

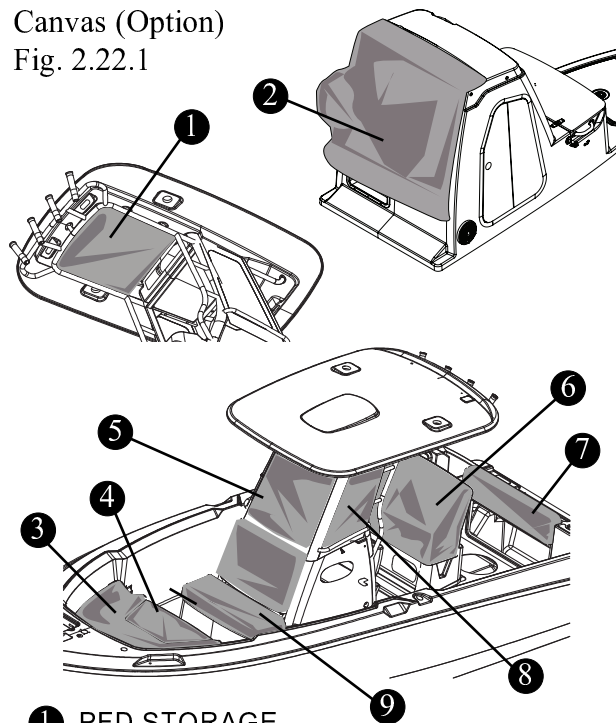

- ① PFD STORAGE
- ② CONSOLE COVER
- ③ BOW CUSHIONS COVER
- ④ BOW TABLE COVER (OPTION)
- ⑤ T-TOP WINDSHIELD COVER
- ⑥ HELM SEAT W/BACKREST COVER
- ⑦ STERN SEAT BACKREST COVER
- ⑧ SIDE CURTAIN
- ⑨ FORWARD CONSOLE SEAT AND BACKREST COVER

Section 2 • General Information

Propeller

NOTICE

- It is advised that you always carry spare propellers, propeller hardware and a propeller wrench on board. Should your propellers become damaged they can then be easily replaced.
- Under no circumstance should you use a propeller which allows the engine to operate at a higher than recommended RPM.

The engine on your 230 Outrage has been equipped with a propeller which our tests have shown to be best suited for general use under normal conditions and load. In some situations you may wish to change the propeller to give your boat slightly different performance characteristics.

Propellers have two basic characteristics, diameter and pitch.

Diameter is that distance measured across the propeller hub from the outer edge of the 360° that is made by the propeller's blade during a single rotation.

Pitch is that distance in inches that a propeller will travel if rotated one revolution without any slippage.

Propeller Pitch & Diameter

Fig. 2.23.2

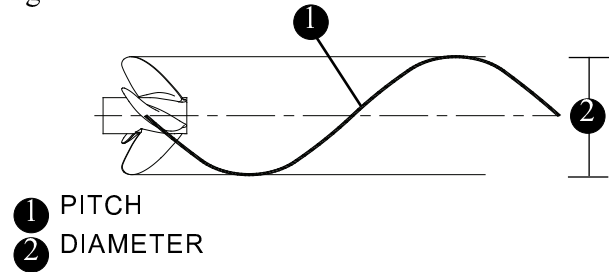

In general, changing to a lower pitch propeller will increase acceleration and load pulling capability, with a slight decrease in top end speed. If you choose to change propellers, the type should be discussed with your Boston Whaler® dealer. All propellers are designed to provide maximum forward thrust, consequently, the reverse thrust of the propeller will not be as efficient.

⚠ DANGER

Disconnect power by moving the battery switches to the "OFF" position prior to removing the propeller for maintenance, etc.

Propeller Assembly

Fig. 2.23.1

- 1 ENGINE SHAFT
- 2 FORWARD THRUST WASHER
- 3 DRIVE SLEEVE
- 4 INNER HUB
- 5 BLADE BACK
- 6 OUTER HUB
- 7 EXHAUST PASSAGE
- 8 DIFFUSER RING
- 9 PROP NUT
- 10 LOCK RING
- 11 DRIVE SLEEVE ADAPTER
- 12 BLADE TIP
- 13 LEADING EDGE
- 14 TRAILING EDGE
- 15 BLADE FACE

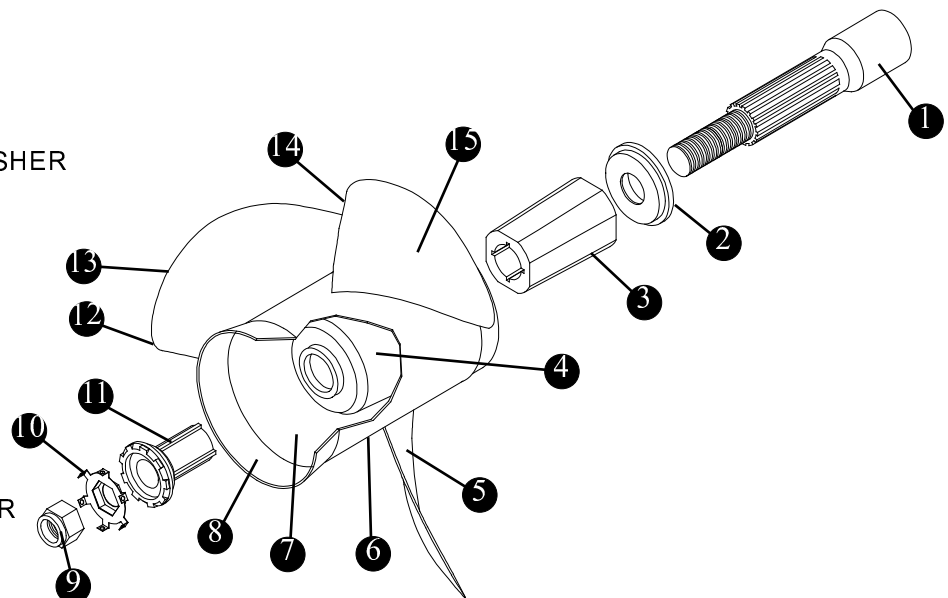

Bow Tow Eye (Option)

! WARNING

PERSONAL INJURY HAZARD

Towing or being towed stresses the boat(s), hardware and lines. Failure of any part can seriously injure people or damage the boat(s).

DO NOT stand directly in line with the tow line. If it were to break, it would "snap Back" causing injury or damage to everything in its path.

The optional bow tow eye which is located on the hull, extreme front of the boat, is reinforced with a stainless steel backing plate located in the anchor locker.

In the event that it becomes necessary for you to have your boat towed, the U.S. Coast Guard or a private salvage company experienced in this type of operation are better equipped to perform the service.

Use another recreational boat only as a last resort. Doing so may cause damage to one or both boats due to operator inexperience or other conditions such as weather and/or current.

In addition, the pitch of most propellers on average recreational vessels is geared toward maximizing the speed of the vessel, not torque, thus making towing inefficient and stressful on the engine.

! CAUTION

NEVER use the tow eye to remove your boat or another vessel which has run aground or for any other usage that would apply similar extreme forces to your boat.

Bow Tow Eye (Option)

Fig. 2.24.1

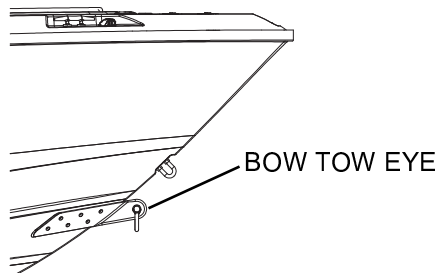

Towing a disabled boat:

If possible, create a bridle with a line around the hull or superstructure or use spring lines to secure the towed vessel to the towing vessel (See below).

Either of these methods will distribute the load over a wide area. Be sure to use fenders or other chafe protection at the pressure points.

Methods of Towing

Fig. 2.24.2

BRIDLE

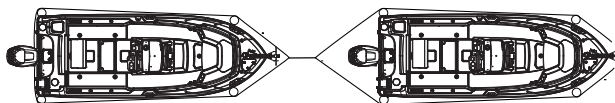

SPRINGS

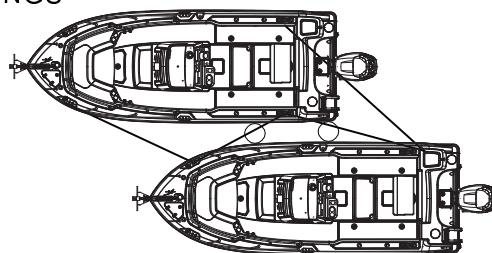

If using the bow eye to tow is the only option:

- Use double-braided or braid-on-braid line. NEVER use three-stranded twisted nylon; it has too much elasticity, can break and "snap back" causing severe injury or damage.
- Attach the tow line to the bow tow eye only. DO NOT attach the tow line to a cleat or deck rail.
- Have towing vessel move slowly to prevent strain on a slack line.
- Keep someone at the helm of the towed vessel to steer.
- Keep lines clear of propellers on both boats.
- Keep hands and feet clear of the other boat.
- NEVER hold a towline after it is pulled taut.

Docking, lifting and trailering

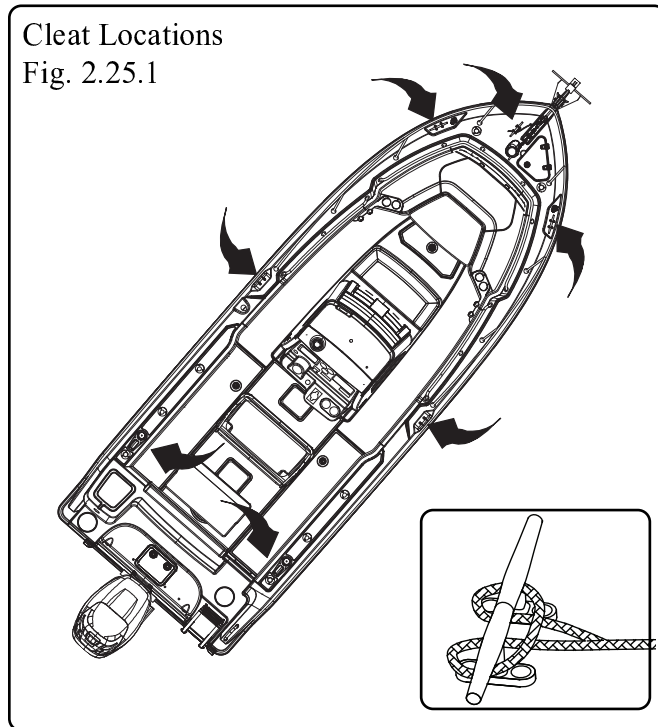

Docking

Your 230 Outrage has seven (7) 8 inch cleats, One (1) at the anchor pulpit, two (2) located at the bow, two (2) amidship, and two (2) with hawse pipes located in the aft cockpit under the port & starboard gunnel.

The cleats are used to secure the boat to the dock while loading/unloading or mooring. Please learn the proper way to secure the boat and how best to use the mooring points of your boat.

Figure 2.25.2 shows the correct method for tying a belaying knot, commonly used to secure a boat to a dock. This knot will hold fast and is simple to release when needed.

Lifting

The bow eye is used to haul out and hold your boat onto a trailer. The stern eyes are used as tie down points while trailering the boat. The bow and stern eyes may be used only for short term lifting of the boat such as service. **Long term lifting with bow and stern eyes will cause stress on the fiberglass and gel coat.**

Belaying Knot

Fig. 2.25.2

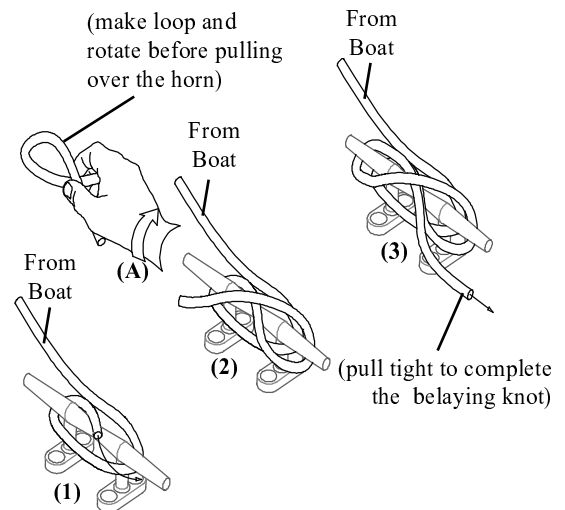

⚠ DANGER

Use only the lifting points specified. Using the cleats for lifting is dangerous and could cause serious injury or death.

⚠ CAUTION

Long term lifting with the bow and stern eyes can cause stress on the fiberglass and gel coat and is not recommended.

For long term lifting or storage, use flat, wide belt-type slings and spreaders long enough to keep pressure from gunwales. **DO NOT** place slings where they may lift on underwater fittings.

Whether you are lifting your boat out of the water for routine maintenance or long term storage, consider the following:

- If you are using a professional lifting service, it is prudent to check all credentials and ask for proof of insurance to protect your investment.
- Use a wide, flat, belt-type sling for lifting, to minimize stress on the gunwales. Careful location of the sling is required. **DO NOT place slings where contact with underwater fittings will occur.**

Proper Short Duration lifting

Fig. 2.26.1

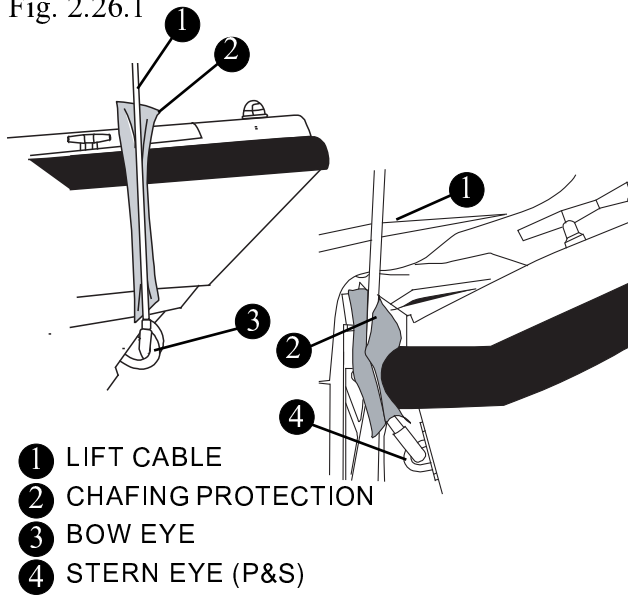

- If you are using a professional lifting service, it is prudent to check all credentials and ask for proof of insurance to protect your investment.
- Use a wide, flat, belt-type sling for lifting, to minimize stress on the gunwales. Careful location of the sling is required. **DO NOT place slings where contact with underwater fittings will occur.**
- If using a lifting hook, attach to bow eye and the stern lifting eyes mounted on the transom. Always use a spreader bar on the stern eyes and use chafing protection on the top of the transom.
- All drain plugs (i.e. transom, fishwell, deck, etc.) should be pulled out and the boat positioned with the bow slightly higher than the stern so that any water which is allowed to accumulate in the cock pit and/or bilge can easily drain from the boat.

Trailer (Option)

Boston Whaler® offers, as an option, a trailer which has been determined to be best suited for the length, width and weight of the 230 Outrage. If you have a trailer or plan on purchasing a trailer for your boat from another source, please consider the following:

- The trailer should have a center roller and keel guards which will help provide good support for the keel as well as good fore and aft support.
- Trailers with bunks provide a more even weight distribution.
- Trailers equipped with rollers instead of bunks can damage the foam sandwich hull of your boat and should never be used.

NOTICE

Your warranty may be void if you use a trailer with rollers. Use a trailer with bunks ONLY

Trailer Safety

Securing the Boat to the Trailer

Safety Chain/Cable - There is a safety chain/cable that attaches to the bow eye and will keep the boat from sliding off the trailer in the event that the winch strap or cable breaks. Hook this up first.

Tie-Down Straps - Can be used to secure the boat from the stern. The tie-down straps hook into the tie-down loops on the trailer frame and to the stern eyes on the transom. Padding (or similar) chafe protection should be used wherever the tie-down straps come in contact with the hull.

Securing the Trailer to the Tow Vehicle

Safety Chains/Cables - Safety chains/cables are also important; the chains/cables are connected to the trailer and should be of sufficient length to reach the frame of the tow vehicle and should be long enough to allow the tow vehicle to turn without binding or tensioning.

Trailer Hitch - A properly matched trailer hitch ball and coupler is important.

Section 2 • General Information

CAUTION

NEVER use a hitchball and coupler that are not matched.

Make certain that the coupler and the hitch ball are properly seated and locked.

DANGER

Tie-down straps should never be used by themselves, they are only used to help in keeping the boat secured to the trailer. Make certain that the safety chain/cable is properly secured to the bow eye.

REFER TO THE ENGINE MANUAL IN YOUR OWNER'S MANUAL PACKET FOR PROPER ENGINE SUPPORT WHILE TRAILERING.

Trailer the Engine

It is best to trailer your boat with the outboard tilted down in a vertical operating position.

However, if additional road clearance is required due to railroad crossings, driveway clearance, trailer bounce, etc., the outboard should be tilted up and supported using an accessory outboard support device.

Your Boston Whaler® dealer will have recommendations regarding the support of your engine.

CAUTION

DO NOT rely on the power trim/tilt system or tilt support lever on your outboard to maintain proper ground clearance for trailering. THE OUTBOARD TILT SUPPORT LEVER IS NOT INTENDED TO SUPPORT THE OUTBOARD FOR TRAILERING

THIS PAGE INTENTIONALLY LEFT BLANK

Bilge Pump

The bilge pump located in the aft bilge is rated at 1100 GPH (4164 LPH). The pump is activated automatically by a float switch (non-mercury) when the water in the bilge reaches a predetermined level.

Operation

A switch on the console switch panel labeled “AFT BILGE” (See figure 2.10.1) controls the operation of the pump. The switch should remain in the AUTO position while in use, unless the operator wishes to manually operate the pump by switching to the on position.

Bilge Pump Switch

Fig. 3.1.1

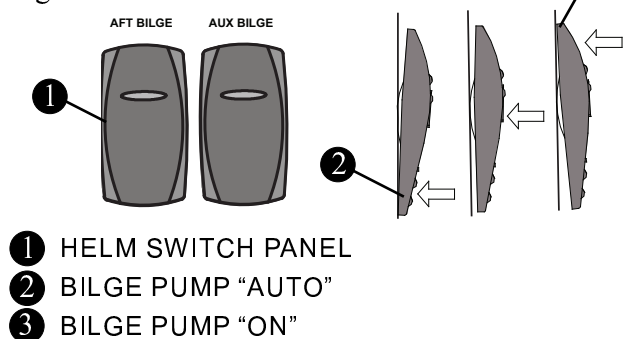

- 1 HELM SWITCH PANEL
- 2 BILGE PUMP “AUTO”
- 3 BILGE PUMP “ON”

NOTICE

The bilge pump is wired directly to the battery. Therefore it is imperative that the float switch remain clear of debris to prevent continuous operation and subsequent discharge of the battery.

Bilge Pump

Fig. 3.1.2

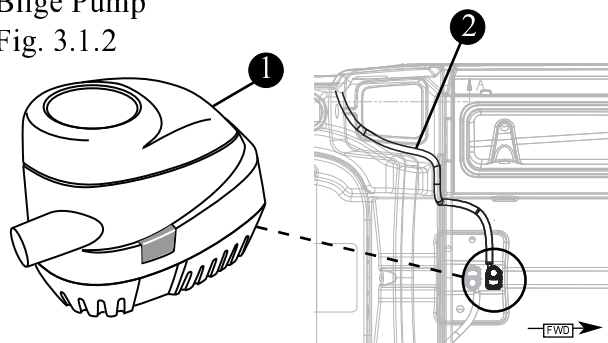

- 1 BILGE PUMP (1100 GPH/4164 LPH)
- 2 DISCHARGE HOSE TO THRU HULL DRAIN

Bilge Pump Maintenance

Fig. 3.1.3

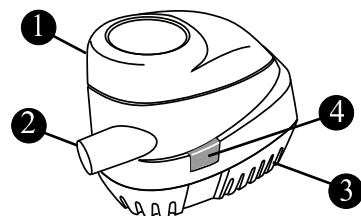

- 1 BILGE PUMP (1100 GPH/4164 LPH)
- 2 OUTLET
- 3 WATER INTAKE
- 4 LOCKING TAB (ON EACH SIDE)

Maintenance

Frequently inspect the area under the float switch to ensure it is free from debris and gummy bilge oil. To clean, soak in heavy duty bilge cleaner for 10 minutes, agitating several times. Check for unrestricted operation of the float. Repeat the cleaning procedure if necessary.

Inspect the bilge pump intakes and keep them free of dirt or material which may impede the flow of water through the pump.

To clean the pump strainer, depress the lock tabs on both sides of the pump and lift the pump motor.

If water does not come out of discharge hose:

1. Remove the motor module to see if the impeller rotates with the power on.
2. Remove any debris that may have accumulated in the nozzle section or strainer base.
3. Check hose and connection on hull side for debris and proper connections.

Fuel & Oil Spillage

Regulations prohibit discharging fuel or oily waste in navigable waters. Discharge is defined as any action which causes a film, sheen or discoloration on the water surface, or causes a sludge or emulsion beneath the water surface. A common violation is bilge discharge. Violators are subject to severe penalties and may also be responsible for the cost of clean up, which can be substantial.

⚠ CAUTION

Oil and fuel spills can be dangerous and can subject offenders to severe penalties

Use rags or sponges to soak up fuel or oily waste, then dispose of them properly ashore. If there is a large quantity of fuel or oil in the bilge, contact a knowledgeable marine service to remove it. Never pump contaminated bilge discharge overboard.

Power Steering

The Verado four-stroke engine uses an enclosed hydraulic pump unit. **The pump is electrically operated to provide hydraulic pressure to the steering system.** The pump is located in the aft portside of the bilge and can be accessed by lifting the equipment hatch in the aft cockpit deck.

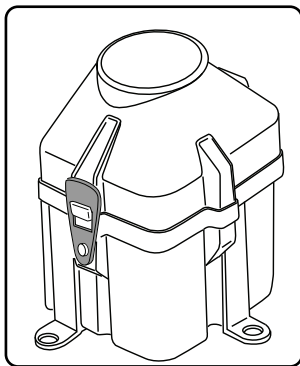

Filling & Maintenance

The system is virtually maintenance free, aside from regular fluid checks and visually inspecting the outside of the unit for signs of leaks or damage.

- Remove the pump cover by pulling up and out on the locking tabs on the sides of the unit.

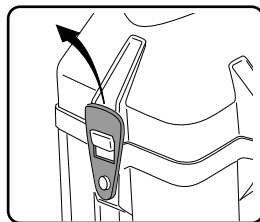

- Unscrew the cap and check the fluid level in the reservoir, fill **ONLY** with SAE 0W-30 Full Synthetic Power Steering fluid if necessary.

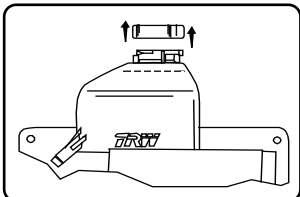

- Replace cap and cover

⚠ CAUTION

Continuous kinking, rubbing and twisting may weaken hose(s) to a point of rupture. Visually inspect all hoses for wear and damage.

Make a habit of checking the fluid level before each trip.

Proper maintenance of this system will ensure worry-free usage for the life of your boat. Steering system integrity is imperative when engaging in recreational water activities. Special care and attention must be taken to ensure proper performance of the steering system and should include the following:

- After the first few hours of operation and at regular intervals, check all fasteners and the complete steering system for security and integrity.
- Inspect for corrosion. Any part affected by corrosion must be replaced.
- When replacing parts, self locking hardware must be used.
- Check the fluid level in the helm pump unit.
- Lubricate slides on the engine cylinders.

All steering systems whether mechanical or hydraulic require regular inspections, periodic adjustment and occasional replacement may be necessary.

⚠ CAUTION

Do not cover cracks in the steering cable or fittings with tape or other sealants. This will create a hazard in which the cable can fail suddenly without warning.

REFER TO THE ENGINE MANUFACTURER'S MANUAL IN YOUR OWNER'S MANUAL PACKET FOR COMPLETE INSTRUCTIONS AND WARRANTY.

Fuel System

NOTICE

If equipped with a 300 or 350 HP Verado® engine, the use of 91 octane fuel is recommended.

CAUTION

- Oil and fuel spills can be dangerous and can subject offenders to severe penalties
- Leaking fuel is a fire and explosion hazard, inspect the system regularly. Examine fuel tanks and exposed lines for leaks and corrosion.

This system has been designed to meet the EPA regulations using certified components to limit the fuel vapor emissions.

Your fuel system provides the following benefits:

- Automotive style refueling, automatic nozzle shut-off, fuel nozzle retention. This system sends a signal to the pump nozzle to shut off before there is any spit-back or well-back through the fill opening.
- Overfill protection is included with each system, reducing the possibility of accidental fuel spills.
- Reduce hydrocarbon emissions through the use of a specially designed fuel fill. This fuel fill has a permanently attached cap

with a positive closure mechanism with an audible click, to let you know when it is sealed.

CAUTION

Use of improper fuel can seriously damage your engine. Engine damage resulting from use of improper fuel is considered misuse of engine and will void the warranty. Follow engine manufacturer's recommendations regarding the types of fuel and oil to use.

NOTICE

it is your responsibility to read and understand the engine manufacturer's manual in your owner's manual packet for complete fuel and fueling information and warnings.

Fuel tank

Your boat is equipped with a low permeation crosslink Polyethylene fuel tank with a useable fuel capacity of 110 gallons (416 L). The useable capacity of the fuel tank is different from the tank

Fuel Tank

Fig. 3.3.1

- 1 FUEL FEED TO ENGINE
- 2 FUEL FILL HOSE
- 3 INTEGRATED CHECK VALVE (ICV)
- 4 FUEL FILL DECK FITTING W/INTEGRATED VENT
- 5 INTEGRATED VENT
- 6 FUEL CAP RELEASE BUTTON
- 7 FUEL VENT HOSE
- 8 110 GAL (416 L) FUEL TANK
- 9 FILL LIMIT VENT VALVE (FLVV)
- 10 GRADE VALVE
- 11 FUEL SENSOR
- 12 FUEL/WATER SEPARATOR
- 13 FUEL DEMAND VALVE (FDV)

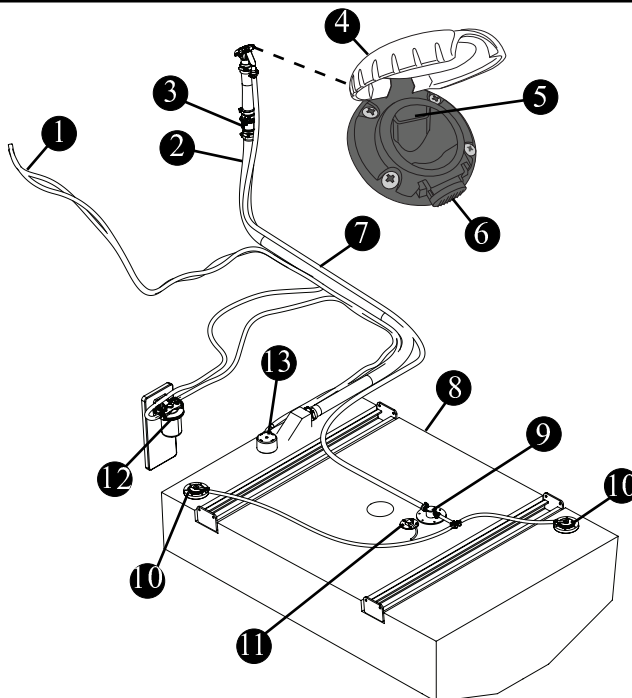

Section 3 • Systems & Components Overview & Operation

capacity marked on the tank from the manufacturer. The difference is the non-useable portion of the tank which results from the fuel in the tank that is below the pickup tube and the ullage area that has been incorporated into your tank. It is recommended that you follow all instructions regarding the filling of fuel tanks. **Please take time to read and understand all the fuel related information and warnings regarding gasoline and your boat, in the engine owner's packet.**

Fuel tanks with levels less than 1/4 full can cause engine stalling problems due to fuel starvation or by allowing sediment and dirt to enter the fuel supply lines. Keep the tank full and monitor the fuel level often to prevent this from happening.

Fuel Vent

The fuel tank vent is integrated into the fuel fill deck fitting (See fig. 3.2.1). The VaporTec fuel pressure management system, (fuel fill deck fitting, integrated check valve, fill limit vent valve, grade valve), ensures that the fuel system constantly maintains proper vapor pressure in all situations. This eliminates any unintended pressure which can seriously damage a boat or engine. The vent serves as an over pressure/vacuum release with anti-surge and flame/spark arresting protection. The fuel vent system also plays an important role in controlling the "FULL" level of fuel with the use of the FLVV (Fill Limit Vent Valve). Grade Valves have been added to the tank which allows proper ventilation of the tank when the boat is stored, or trailered, on a moderate incline, without fuel seepage.

Filling The Tank

This fuel system is designed to automatically shut off the fuel nozzle when the tank is full, similar to an automotive fuel system. The tank is filled when the fuel fill nozzle has shut itself off the second time. The SecureStop automatic fuel shutoff system (Fuel Fill Deck Fitting, Integrated Check Valve, Fill Limit Vent Valve), guarantees the boater a clean trouble-free fillup. Details such as valve design and deck fill nozzle retention features ensure consistent fillup/shutoff. Attempting to fill the tank past this point may cause some of the components to not function properly, or malfunction.

Fuel Distribution System

The fuel is delivered from the tank to the engine through the Fuel Demand Valve (FDV), anti-siphon valve, and the fuel line. The FDV prevents the built up pressure inside the tank from being transferred to the engine while still allowing fuel to flow as the engine requires it for operation. The anti-siphon valve is a safety feature designed to prevent the fuel from siphoning out of the tank if the fuel line were to be cut or broken below the level of the fuel in the tank. In this case, some fuel would leak from the line, but would not allow the entire contents of the tank to siphon into the boat.

WARNING

The use of a portable fuel tank to fill your boat's tank can result in overfilling and circumvent the safety features designed into your tank.

WARNING

The modification of any of the fuel system components or the replacement of these components with unauthorized parts may result in over-pressurization of the fuel system and circumvent the safety features designed into your tank.

NOTICE

Keep records of the fuel capacity and consumption of your boat. Drastic changes in consumption and mileage may indicate a problem.

NOTICE

FUEL GAUGE only reads accurately when boat is level (not underway).

REFER TO THE ENGINE MANUFACTURER'S MANUAL IN YOUR OWNER'S MANUAL PACKET FOR COMPLETE INSTRUCTIONS AND WARRANTY.

Static Electricity and the Fuel System

DANGER

Static electricity can ignite gasoline vapors causing serious injury/death and/or destruction of property.

Section 3 • Systems & Components Overview & Operation

There is a danger that static electricity can ignite gasoline vapors that have not been ventilated outside an enclosed area. Use extreme caution when fueling your boat from a source outside the regular venues, (e.g. marinas, fuel service stations.)

Your boat has safety features that can be circumvented by not adhering to standard fueling practices.

Your boat's bonding system protects it from creating and discharging static electricity.

Your boat must be in contact with the water or a land based grounding system. Here are some helpful suggestions to keep you safe from static electricity while refueling your boat.

- NEVER fuel your boat in unsafe conditions such as: suspended on a sling or in a situation that increases the likelihood of static discharge.
- NEVER use homemade containers to fill your fuel tanks.
- Fuel carried on-board outside of a fixed fuel system should be stored in an approved container or in a portable tank such as provided for outboard engines and be stowed safely outside of the engine or living compartment(s).
- Shut down the engine, motors and fans prior to taking on fuel. Any ignition sources should be extinguished before filling the fuel tank.
- Close all ports, windows, doors and hatches.
- Fueling should never be done at night except in well-lighted areas.
- Always keep the fuel nozzle in contact with the fuel fill plate or the edge of the fuel tank opening throughout the filling process.
- Allow areas where gasoline vapors could collect to be ventilated before starting the engine.
- Wipe any spillage completely and dispose of rags or waste on shore.
- Secure the fill cap tightly.
- Portable tanks should only be filled while on the ground; never on-board the boat.

Your boat has safety features that can be circumvented by not adhering to standard fueling practices.

REFER TO THE “DO’S AND DON’TS AT THE GAS PUMP” DVD IN YOUR OWNER’S MANUAL PACKET FOR MORE INFORMATION.

Ethanol-Blended Fuels

Ethanol is an oxygenated hydrocarbon compound that has a high octane rating and therefore is useful in increasing the octane level of unleaded gasoline.

The fuel-system components of your Mercury engine(s) have been tested to perform with the maximum level of ethanol-blended gasoline (10% ethanol) currently allowed by the EPA in the United States.

NOTICE

The use of improper gasoline or additives can damage your fuel system and is considered misuse of the system. Damaged caused by improper gasoline or additives WILL NOT be covered under warranty.

Special precautions should be considered with the use of fuel containing ethanol in your system. Fuels with ethanol can attack some fuel-system components, such as tanks and lines, if they are not made from acceptable ethanol-compatible materials. This can lead to operational problems or safety issues such as clogged filters, leaks or engine damage.

Your boat was manufactured, and shipped from the factory, with ethanol-compatible materials. Before introducing gasoline with ethanol into your fuel tank, ask your dealer if any components have been added or replaced that are not recommended by Boston Whaler, Mercury or may not be ethanol-compatible.

Filling The Tank

It is best to maintain a full tank of fuel when the engine is not in use. This will reduce air flow in and out of the tank due to changes in temperature as well as limiting exposure of the ethanol in the fuel to humidity and condensation.

Example of Phase Separation

Fig. 3.6.1

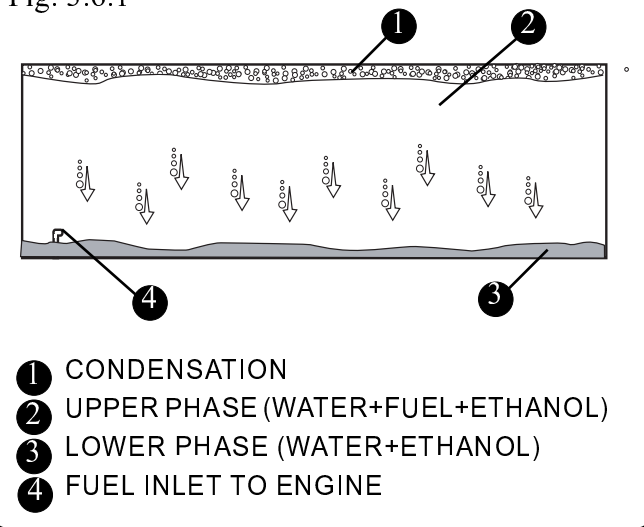

Phase Separation

Humidity and condensation create water in your fuel tank which can adversely effect the ethanol blended fuel. A condition called phase separation can occur if water is drawn into the fuel beyond the saturation point. The presence of water in the fuel beyond the saturation level will cause most of the ethanol in the fuel to separate from the bulk fuel and drop to the bottom of the tank, significantly reducing the level of ethanol in the fuel mixture in the upper level (phase). If the lower level (phase), consisting of water and ethanol, is deep enough to reach the fuel inlet, it could be pumped directly to the engine(s) and cause significant problems. Engine problems can also result from the reduced ethanol/fuel mixture left in the upper phase of the tank.

Additives

There is no practical additive known that can prevent or correct phase separation. The only solution is to keep water from accumulating in the tank.

If phase separation does occur, your only remedy is to drain the fuel, clean and dry the tank completely and refill with a fresh, dry load of fuel.

Fuel Filters

Mercury already provides the appropriate level of filtration to protect the engine from debris. The addition of another *in-line* filter to the system may create a possible flow restriction that can starve the



CAUTION

The use of fuels containing ethanol higher than 10 percent (E-10) can damage your engine and/or fuel system and will void the warranty.

E85 FUELS COULD SERIOUSLY DAMAGE YOUR ENGINES AND MUST NEVER BE USED.

engine(s) of fuel. It is advisable to carry extra *on-engine* filters in case filter plugging from debris in the fuel tank becomes a problem during boating.

Your Boston Whaler dealer will have recommendations regarding filters that meet Mercury's specifications.

The fuel/water separator has been determined to be within Mercury specifications and will not restrict the flow of adequate fuel to the engine(s).

Fuel/water Separator

The fuel/water separator has been determined to be within Mercury specifications and will not restrict the flow of adequate fuel to the engine(s).

Maintenance

Periodically inspect for the presence of water in the fuel tank. If any is found, all water must be removed and the tank completely dried before refilling the tank with any fuel containing ethanol.

Storage

Long periods of storage and/or non-use, common to boats, create unique problems. When preparing to store a boat for extended periods, of two months or more, it is best to completely remove all fuel from the tank. If it is not possible to remove the fuel, maintaining a full tank of fuel with a fuel stabilizer added to provide fuel stability and corrosion protection is recommended.

- Add fuel stabilizer/treatment at manufacturers recommended dosage.
- Run engine(s) for 10 minutes.
- Shut OFF fuel valve.
- Allow engine to run until it stops.

Section 3 • Systems & Components Overview & Operation

- Top off fuel tank, leaving space for expansion. DO NOT fill to point of overflow.
- DO NOT cap the tank vent.

A partially full tank is not recommended because the void space above the fuel allows air movement that can bring in water through condensation as the air temperature moves up and down. This condensation could potentially become a problem.

Starting the Engine

CAUTION

NEVER start or operate your outboard (even momentarily) without water circulating through all the cooling water intake holes in the gearcase to prevent damage to the water pump (running dry) or overheating of the engine.

The ignition keyswitch located starboard of the helm incorporates the following settings:

OFF = No power to engine, instrument panels, etc.

RUN = Power to instrument panels and gauges

START = Power to start engine

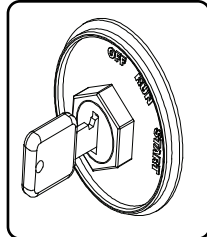

Prior to Starting

- Make sure that the lower unit of the engine is in the water.
- Make certain the gear shift/throttle control is in the neutral position. (The engine will not start if the control lever is in any other position than NEUTRAL)

NOTE: The engine can be started by using the ignition key or the start/stop button located on the remote control handle.

Ignition key starting

Turn the ignition key to the “START” position and release the key. The electronic starting system will automatically crank the engine for starting. If the engine fails to start, the engine will stop cranking. Turn the key to “START” position again until engine starts.

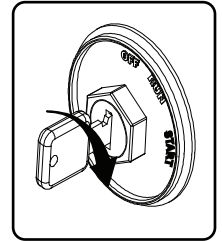

DTS Stop/Start Button starting

Turn the ignition key to the “ON” position and press start/stop button and release. The electronic starting system will automatically crank the engine for starting. If the engine fails to start, the engine will stop cranking. Press start/stop button and release again until engine starts.

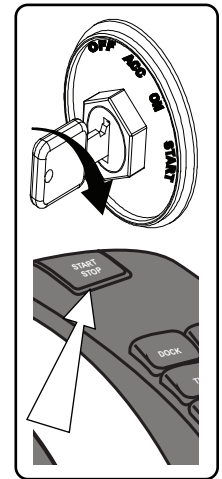

Stopping The Engine

Make sure the boat is securely moored to the dock before shutting down the engine.

Shift gearshift/throttle control to the “NEUTRAL” position and turn keyswitch to the “OFF” position.

If using the optional DTS® System, when powering down it is recommended that you turn the keyswitch to “START”. This will stop the engine, and still give you power to trim the engine.

Reduce engine speed and shift outboard to “NEUTRAL”. Turn keyswitch “OFF”.

REFER TO THE ENGINE MANUFACTURER’S MANUAL IN YOUR OWNER’S MANUAL PACKET FOR COMPLETE INSTRUCTIONS.

Fresh Water System (Option)

If equipped, the freshwater system includes: Pump, plumbing, holding tank and connections for water service to the shower located on the starboard side of the aft cockpit.

The 20 Gal. (76 L) freshwater tank is located in the aft bilge and can be reached through an access plate in the motorwell.

The fill cap is located on the aft starboard side of the boat. Fill the tank only from a source known to provide safe, pure drinking water. Use only a plastic hose to fill the water tank. Using a rubber hose can give the water a disagreeable taste.

Before you fill the freshwater system it is vital that it be properly disinfected. Ask your dealer if this has been done.

The following procedure is recommended to disinfect the freshwater system:

1. Flush the entire system thoroughly by allowing potable water to flow through it.

NOTICE

- **Be sure to fill the water tank from a source known to provide safe, pure drinking water.**
- **If you do not use the freshwater system for long periods of time or only use it seasonally it is recommended that you follow the disinfecting practice before using it.**

2. Drain the system completely.
3. Fill the entire system with an approved disinfecting solution (check with your dealer for recommendations) and follow the method prescribed by the manufacturer.
4. After disinfecting, drain the entire system.
5. Flush the entire system thoroughly several more times with potable water.
6. Now the system is ready for use, fill with potable water.

This should be done annually or before using the system if it has been laid up for an extended amount of time.

Fresh Water System (Option)

Fig. 3.8.1

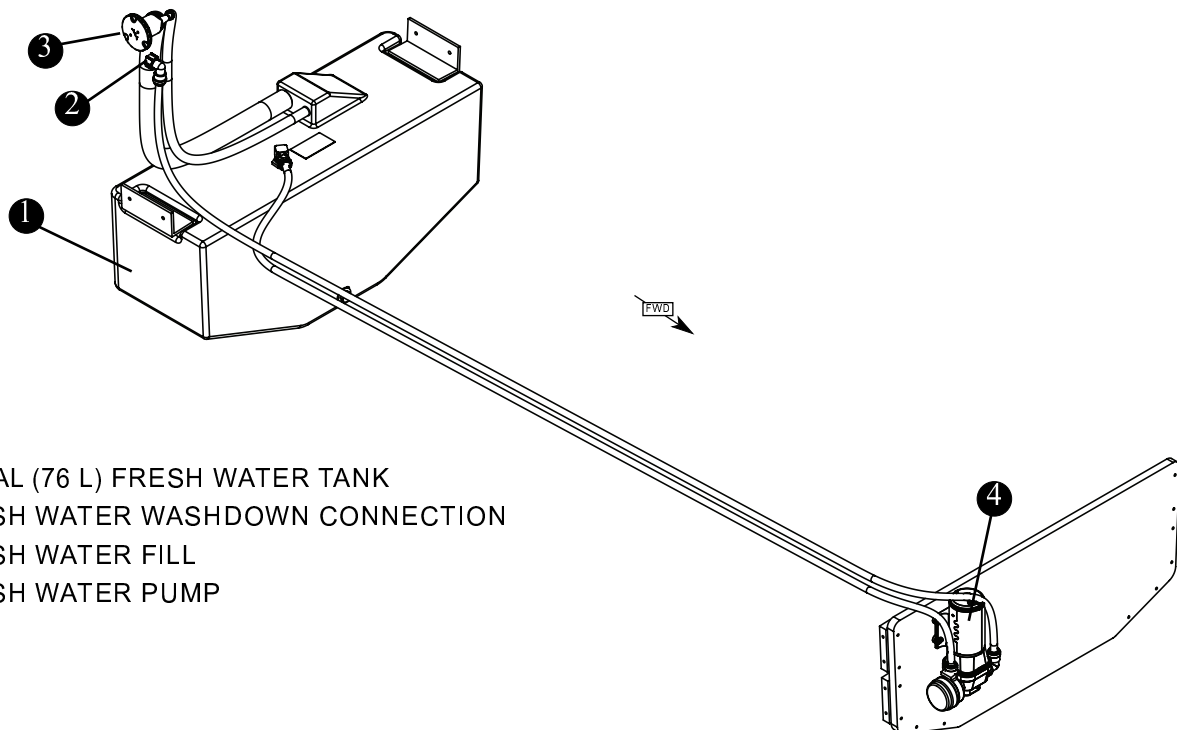

Raw Water System

The raw water washdown deck fitting is located on the port side of the aft cockpit. A 3.5 GPM (13 LPM) pump supplies seawater to the deck fitting. The fitting allows for connection of a common garden hose.

Operation

ATTENTION

The seacock MUST be in the OPEN position when washdown is in use. Running the pump dry may damage the unit.

The raw water washdown pump is activated by the “WSH DWN” switch on the console switch panel (See figure 2.10.1).

The seacock for the pump must be in the OPEN position before using. The seacock can be accessed through the aft cockpit deck access plate.

Maintenance

Maintenance of the raw water system will require you to check the fittings and hoses for system integrity to prevent leaks.

Periodically check the in-line strainer attached to the pump, and clean if necessary.

The system should be run at least every other month to maintain the pump’s impellers in a stable operating condition.

The raw water pump can be accessed through the forward cockpit deck access plate.

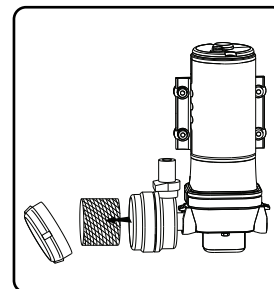

Livewell

Your boat is equipped with an insulated, 16 Gal. (60.6L) livewell that is located in the aft port cockpit. The livewell system’s primary function is to keep baitfish

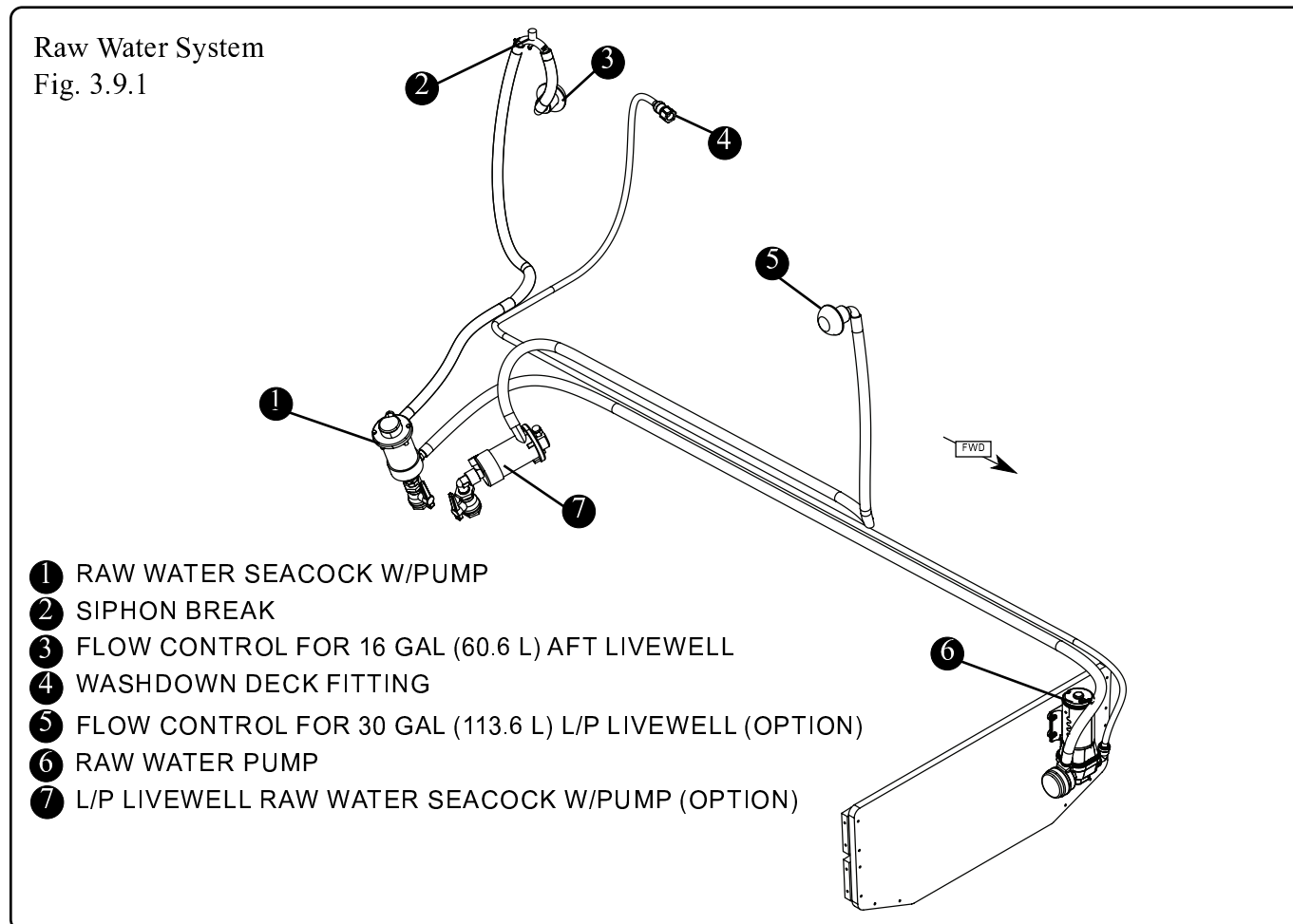

Section 3 • Systems & Components Overview & Operation

Livewell
Fig. 3.10.1

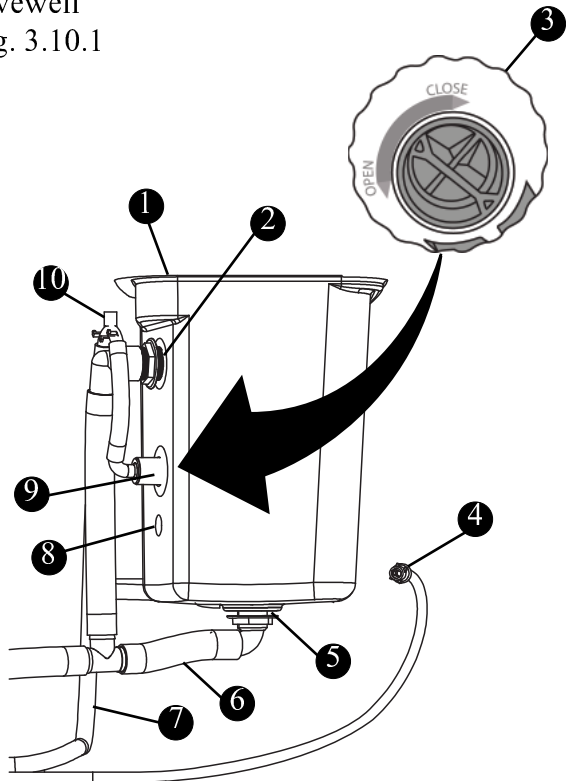

- ① 16 GAL (60.6 L) LIVEWELL
- ② UPPER DRAIN
- ③ FLOW CONTROL VALVE
- ④ WASHDOWN DECK FITTING
- ⑤ BOTTOM DRAIN
- ⑥ TO TRANSOM THRU HULL
- ⑦ FROM SEACOCK PUMP
- ⑧ LED LIGHT
- ⑨ RAW WATER INLET
- ⑩ SIPHON BREAK

alive by circulating seawater into the livewell bucket. The seacock, plumbing and raw water pump that service the system can be reached through the deck access plates (See fig. 2.8.1).

Operation

The livewell can be filled by using the switch marked “AFT LIVEWELL” on the console switch panel (See figure 2.10.1).

Before filling the livewell, you must make certain the hull seacock is in the open position. The hull seacock can be accessed through the aft cockpit deck access hatch (See fig. 2.8.1).

A flow control valve (Figure 3.10.1) at the livewell water inlet controls the flow of water into the livewell. To increase the water flow, turn the valve counterclockwise. To decrease flow, turn the valve clockwise.

Deluxe Leaning Post Livewell (Option)

Your boat may be equipped with an insulated 30 Gal. (113.6 L) livewell that is located under the cushion of the deluxe leaning post.

Operation

ATTENTION

The seacock MUST be in the OPEN position when livewell is in use. Running the pump dry may damage the unit.

The livewell can be filled by using the switch marked “L/P LIVEWELL” on the console switch panel (See figure 2.10.1).

Before filling the livewell, you must make certain the hull seacock is in the open position. The hull seacock can be accessed through the cockpit deck hatch (See fig. 2.8.1).

A flow control valve at the livewell water inlet controls the flow of water into the livewell. To increase the water flow, turn the valve counterclockwise. To decrease flow, turn the valve clockwise.

Livewell (Option)
Fig. 3.10.2

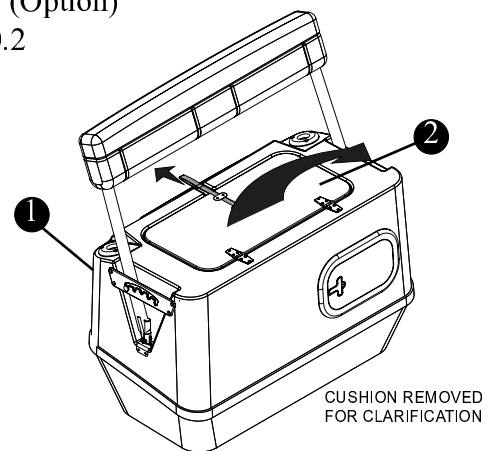

- ① DELUXE LEANING POST (OPTION)
- ② 30 GAL (113.6 L) LIVEWELL (OPTION)*

* UNDER LID

Deluxe Leaning Post Livewell (Option)

Fig. 3.11.1

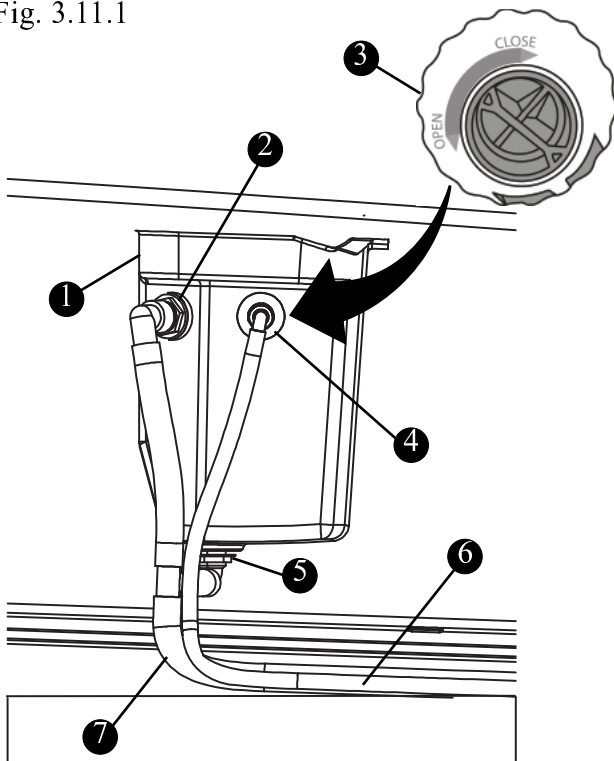

- ① 30 GAL (113.6 L) LIVEWELL
- ② UPPER DRAIN
- ③ FLOW CONTROL VALVE
- ④ RAW WATER INLET
- ⑤ BOTTOM DRAIN
- ⑥ FROM SEACOCK PUMP
- ⑦ TO TRANSOM THRU HULL

NOTICE

Having both the raw water seacock and flow control valve open at the same time will fill the livewell with water.

If you wish to use the livewell for dry storage, make certain to **CLOSE** the raw water seacock and/or the flow control valve. Failure to do so will allow water to enter the livewell bucket.

Maintenance

Maintenance of the livewell system will require you to check the seacock intake strainer for debris and impediments, this can be done visually on dry land. The intake strainer is located on the bottom aft of the hull on the port side.

Head System

Portable Head w/ Pump-Out & Overboard Discharge (Option)

Your boat is fitted with a portable waste containment system. The system is located in the forward console. The portable head has a lower tank and an upper tank. Waste is directed to the lower section of the tank which has a holding capacity of 2.8 gal. (10.6L).

NOTICE

Severe state and federal penalties are levied for discharging raw sewage and/or solid waste in waters where it is not permitted.

NOTICE

This boat may be equipped with an overboard discharge seacock.

Severe state and federal penalties are levied for discharging raw sewage and solid waste in waters where it is not permitted.

Demonstrating that you have disabled the macerator by locking the system and/or removing the seacock handle may avoid a fine.

It is also illegal for any vessel to dump plastic trash anywhere in the ocean or navigable waters of the United States.

Portable Head

Fig. 3.11.2

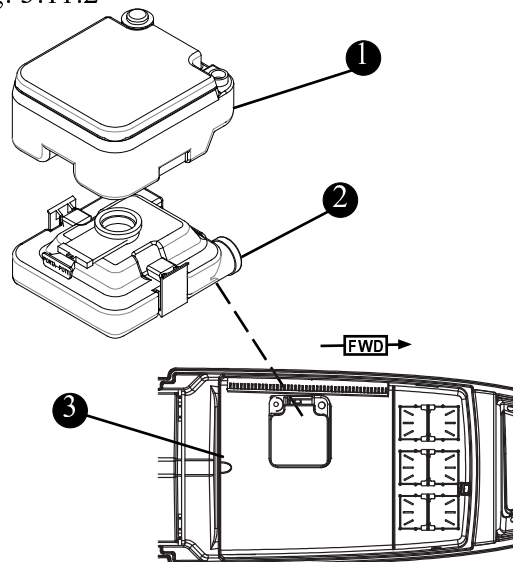

- ① PORTABLE HEAD UPPER UNIT
- ② WASTE CONTAINMENT UNIT
- ③ FORWARD CONSOLE

Section 3 • Systems & Components Overview & Operation

Environmental Considerations

The Environmental Protection Agency (EPA) standards state that in freshwater lakes, reservoirs, impoundments whose inlets or outlets are such as to prevent the ingress or egress by vessel traffic subject to this regulation, or in rivers not capable of navigation by interstate traffic subject to this regulation, marine sanitation certified by the United States Coast Guard (U.S.C.G.) installed on vessels shall be designed and operated to prevent the overboard discharge of sewage, treated or untreated or any other waste derived from sewage.

The EPA standards further state that this shall not be construed to prohibit the carriage of Coast Guard certified flow through treatment devices which have been secured so as to prevent such discharges. They also state that the waters where a Coast Guard certified marine sanitation device permitting discharge is allowed include: Coastal waters, Estuaries, The Great Lakes and Intercoastal waterways, Freshwater lakes and Impoundments accessible through locks and other flowing waters that are navigable interstate by vessels subject to this regulation. (40 CFR, 140.3)

FOLLOW ALL INSTRUCTIONS PERTAINING TO THE OPERATION, CARE, AND MAINTENANCE OF THE WASTE SYSTEM IN YOUR MARINE TOILET MANUAL.

Dockside Pumpout & Overboard Discharge (Option)

The 230 Outrage may be equipped with a 5.2 Gal. (19.7 L) portable waste containment system located in the forward console. The unit has a lower tank and an upper tank. The upper tank holds freshwater used for flushing the system. The lower tank hold the waste to be pumped out.

Dockside Pumpout

NOTICE

Dockside pumpout is the preferred method of waste disposal.

The dockside discharge deck plate is located on the port side of the console and is marked “WASTE” (Figure 3.12.1). Access is gained by use of a special key that is included in the owner’s manual packet.

The dockside facility will have a connection to fit your boat.

If equipped, the optional head system includes a portable head, macerator, lockable discharge seacock, dockside pump-out connection and vent.

The macerator/discharge pump draws solid and liquid waste from the holding tank and processes it prior to discharging it overboard through the macerator seacock located in the aft bilge. The macerator is designed to handle waste, toilet and facial tissue and will not pump solids. The key necessary to actuate the overboard discharge unit can be found in your owner’s manual packet.

NOTICE

Because your waste system is a “low water” use system, there is special paper which MUST be used to prevent clogs. The manufacturer has provided information regarding the type of paper that must be used.

NEVER use residential tissue paper in your marine waste system.

The macerator control panel is located on the aft wall of the head compartment. **To Operate the Macerator:**

- Make sure the discharge seacock is in the open position.
- Insert the macerator key, which is included in your owners manual packet, into the panel.
- Turn the key clockwise and hold it there. The keyswitch is a momentary type, which means that it needs to be held during the discharge cycle. Turning the keyswitch clockwise will discharge the contents of the holding tank through the macerator pump, which processes it before evacuating it overboard.
- When you are satisfied that the tank has been emptied, return the key to the upright position.

WARNING

The discharge seacock should always be in the closed position when the toilet is not in use. Failure to do so could result in flooding, property damage and/or loss of life.

Section 3 • Systems & Components Overview & Operation

Portable Head w/dockside pumpout & Overboard Discharge (Option)

Fig. 3.13.1

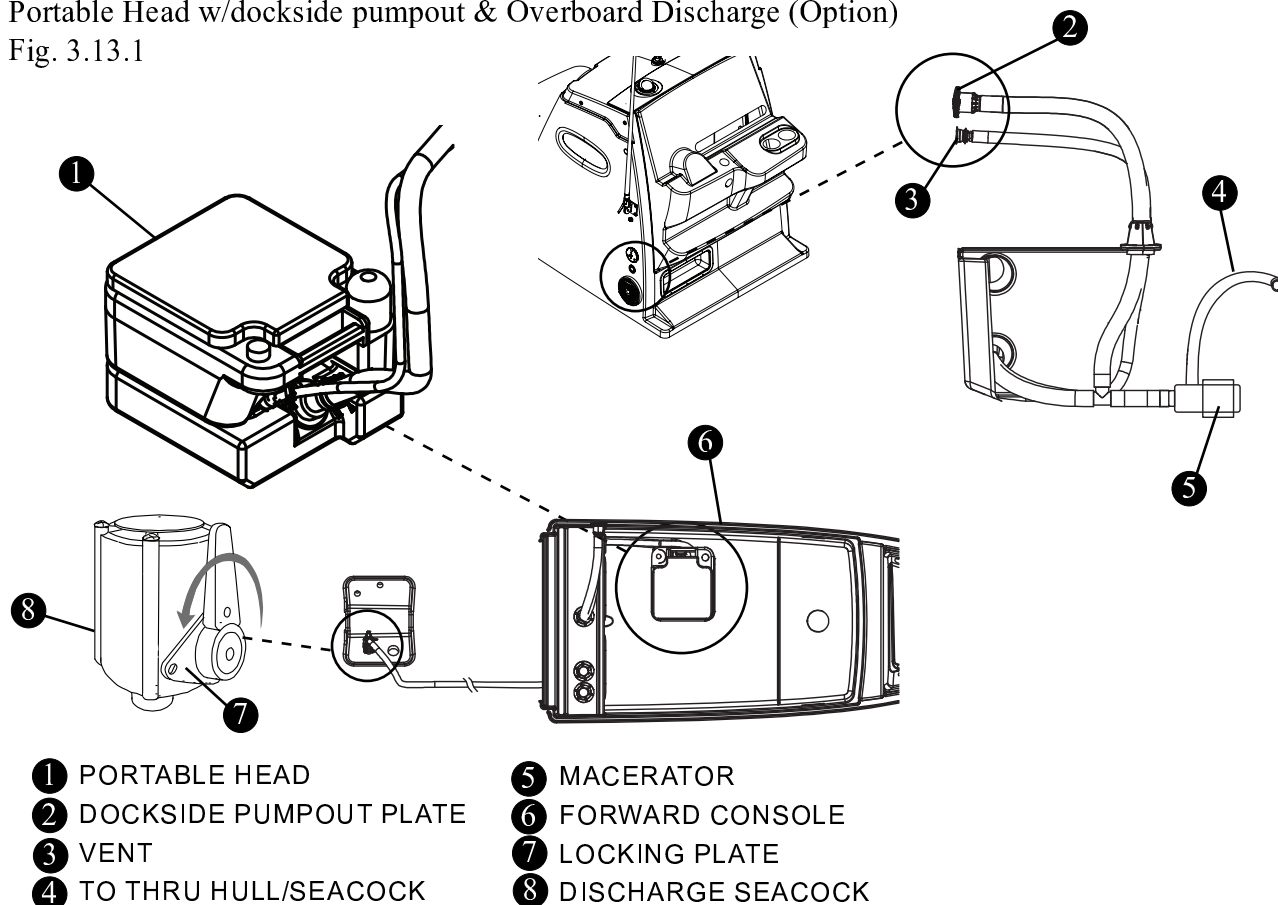

Macerator Control Panel

Fig. 3.13.2

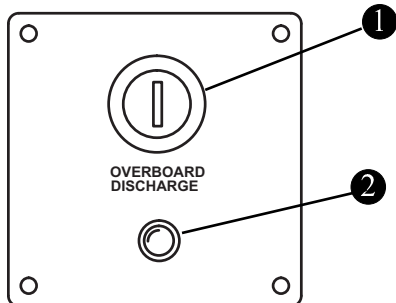

- 1 MACERATOR KEYSWITCH
- 2 BREAKER (25A)

To Lock the Discharge Seacock,

rotate the handle until the hole in the handle is aligned with the hole in the locking plate and insert a padlock (not supplied).

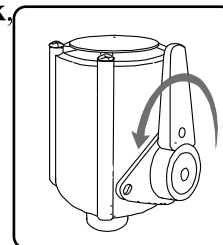

Maintenance

After long periods of non-use, the macerator pump may not turn freely. Regular use of the system will reduce the chances of this occurring. If the system does require maintenance contact your nearest dealer.

Because your waste system is a low water use device, there is special paper which must be used to prevent clogs.

NOTICE

NEVER use residential tissue paper in your marine waste system.

REFER TO THE MANUFACTURER'S MANUAL IN YOUR OWNER'S MANUAL PACKET FOR COMPLETE INSTRUCTIONS AND WARRANTY.

Entertainment System (Option)

The entertainment system on your boat consists of a Fusion® AM/FM stereo w/four (4) waterproof speakers, two (2) MP3/USB inputs and bluetooth enabled. The USB/MP3 inputs are located on the helm switch panel and in the lockable glove box (Figure 3.14.1). The stereo unit is located on the starboard side of the console. The waterproof speakers are located throughout the boat.

Operating Your Stereo Using Your MP3 Player or USB Device (Option)

The MP3 input on your boat uses a standard 1/8" mini stereo cable (not included) which can be purchased at any electronic store.

- Insert one end of the stereo cable into your MP3 player and the other end into the MP3 input or Insert a USB device into the USB input located on the starboard side of the emergency shutoff switch.
- Turn the stereo ON.
- Press the 'source' button and cycle to USB.

Stereo (Option)
Fig. 3.14.1

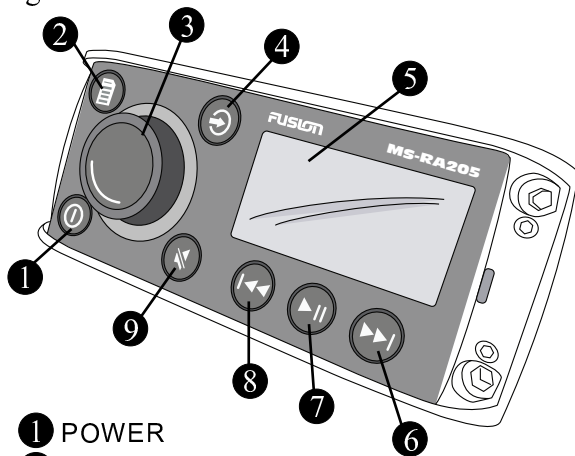

- 1 POWER
- 2 MENU
- 3 ROTARY ENCODER
- 4 SOURCE
- 5 DISPLAY SCREEN
- 6 FORWARD/NEXT
- 7 PLAY/PAUSE
- 8 BACK/PREVIOUS
- 9 MUTE

- Press 'menu' and select DISK.

Note: We recommend you name your USB device allowing the device name to be displayed. Default name of a connected device is 'DISK'.

You will be able to control volume and menu from either your MP3 unit or the stereo.

NOTICE

Ensure the USB device is formatted as Fat32 format.

MP3/USB Operation (Option)
Fig. 3.14.2

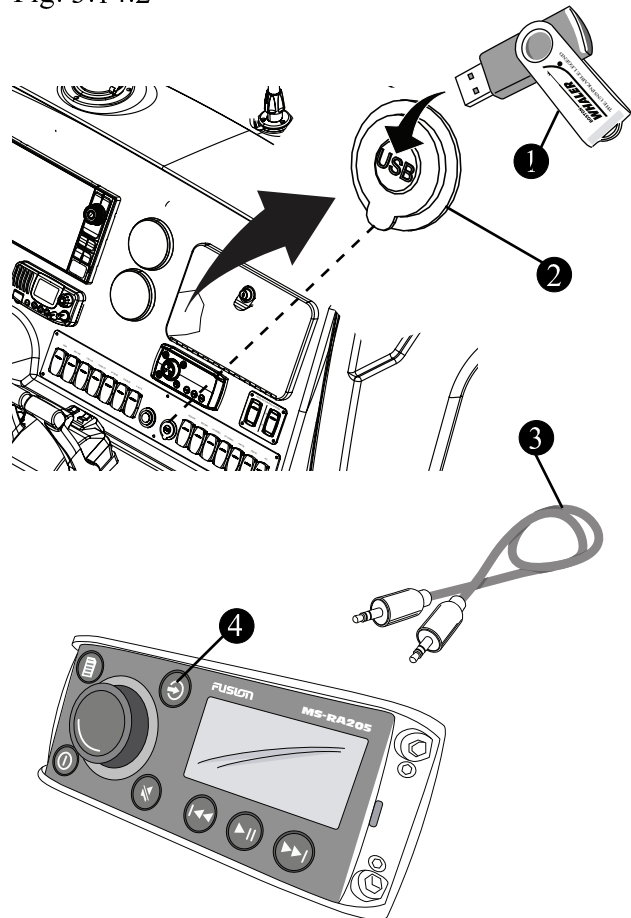

- 1 USB FLASH DRIVE (NOT SUPPLIED)
- 2 USB/MP3 INPUT
- 3 1/8" MINI STEREO CABLE (NOT SUPPLIED)
- 4 SOURCE BUTTON

REFER TO THE MANUFACTURER'S MANUAL IN YOUR OWNER'S MANUAL PACKET FOR COMPLETE INSTRUCTIONS, INFORMATION AND WARRANTY.

Helm Bench seat

The helm bench seat on your boat is enhanced with unique features which add convenience and comfort to your experience. Features include a flip down utility shelf and fold away reverse facing seating.

To Lower The Utility Shelf

- Release the latches (P&S) (Figure 3.15.1) by pulling back away from the seat.
- Lower the shelf until it is fully deployed.

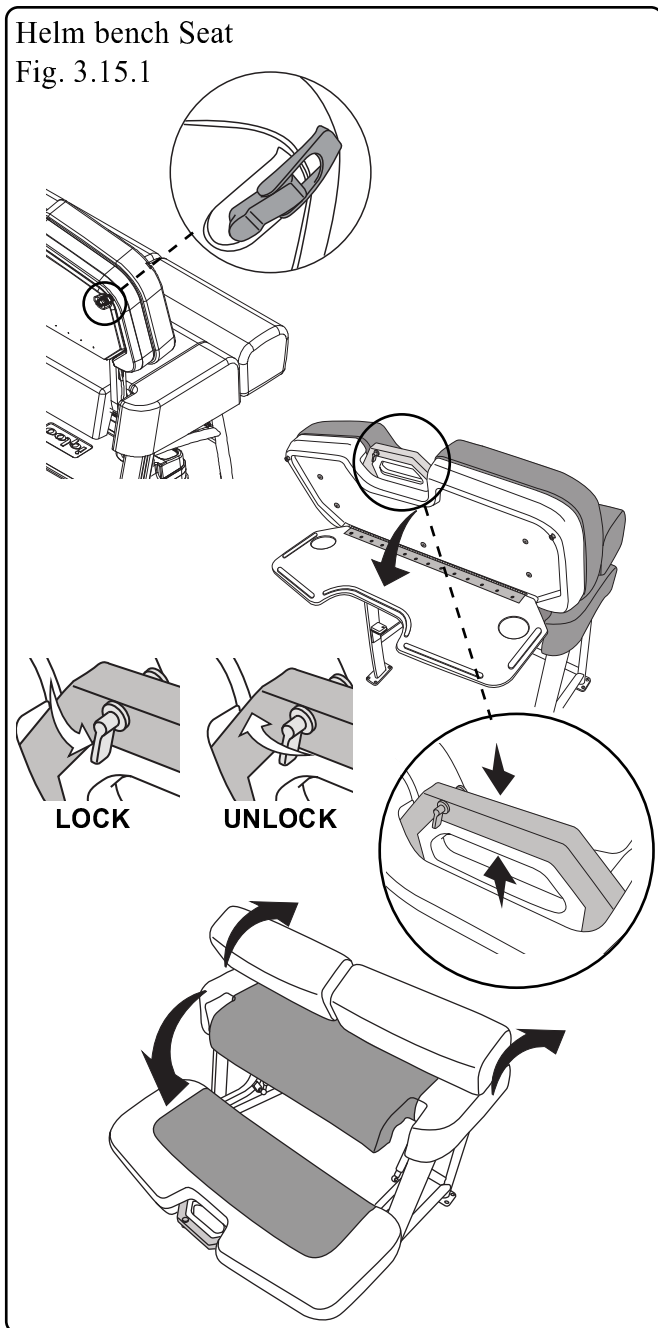

To Lower The Reverse Facing Seat

- Unlock the handle by turning the locking latch clockwise (Figure 3.15.1).
- Grab the handle and squeeze it together.
- Pull the seat and rotate until fully deployed.
- After use, return seat to upright position and lock in place by turning locking latch counter clockwise until it “clicks” in place.

Bow In-Floor Storage/Gutter Drain

The gutter drain seacock should be kept open.

Exceptions:

- Hose becomes detached from gutter drain.
- Hose becomes detached from seacock.

If either of the above exceptions occur the seacock must be closed to avoid flooding the storage area with seawater.

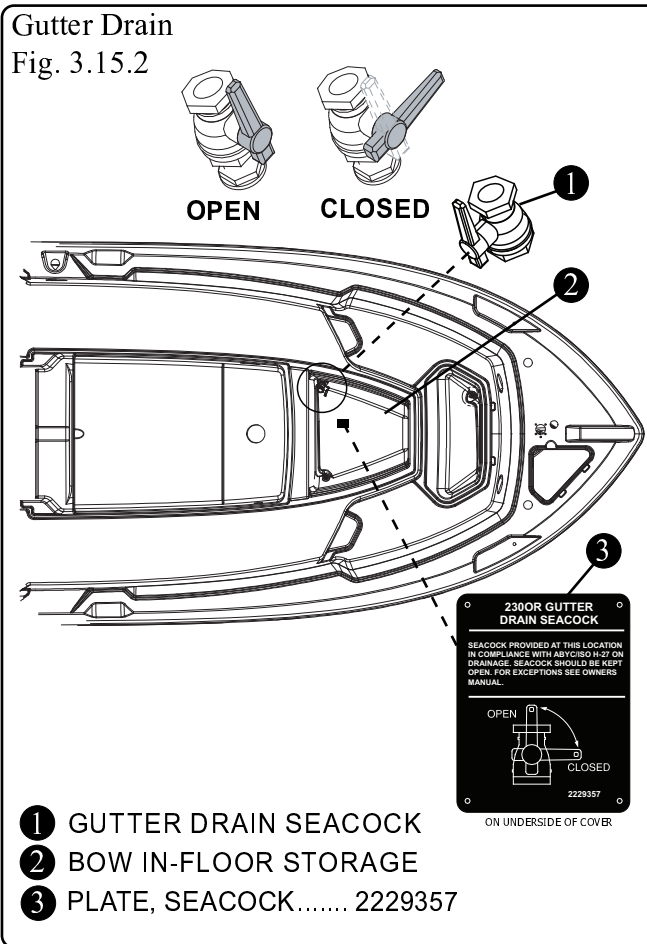

Ski Pylon(Option)

Ski Pylon (Option)
Fig. 3.16.1

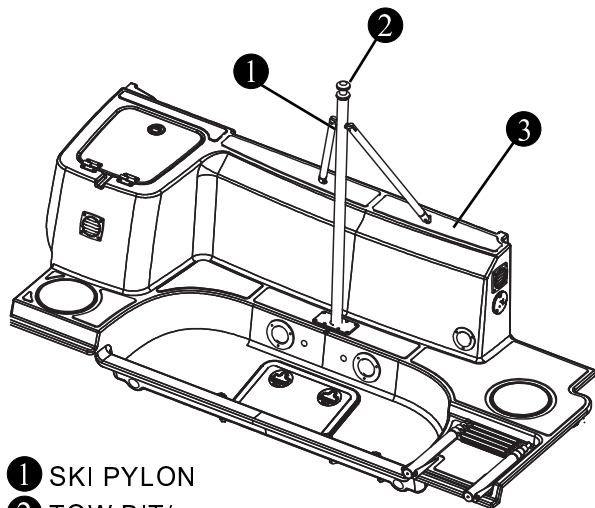

- ① SKI PYLON
- ② TOW BIT/
- ③ TRANSOM

CAUTION

DO NOT USE THE SKI PYLON WITH ANY EQUIPMENT WHICH IS TIED TO THE TOW ROPE!

The ski pylon is for skiing and/or wakeboarding ONLY. If engaged in tubing or such other recreational towing, it is recommended that you attach the tow rope to the stern eyes at the transom of your boat.

Recreational Safety

Be sure to read and understand the safety rules for recreational activities presented in Section 1, pages 1-13 thru 1-15 of this manual.

Bow Filler (Option)

If selected, the bow table can be installed to extend the forward lounge, incorporating the bow cushions to provide a large lounge area in the bow of your boat,

Bow Filler (Option)*
Fig. 3.16.2

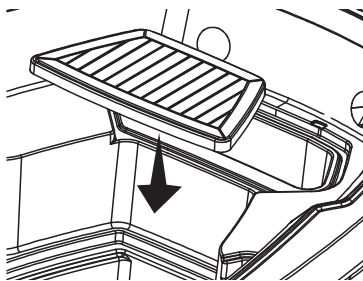

* Must select bow table option

Bow Table (Option)

To install the optional bow table, place the single support stand into the receptacle and place the table top onto the top of the stand. When not in use, the bow table and stand pipe can be stowed in the console. Slide the table top into the storage brackets and secure the elastic straps to hold the table in place.

Bow Table (Option)
Fig. 3.16.3

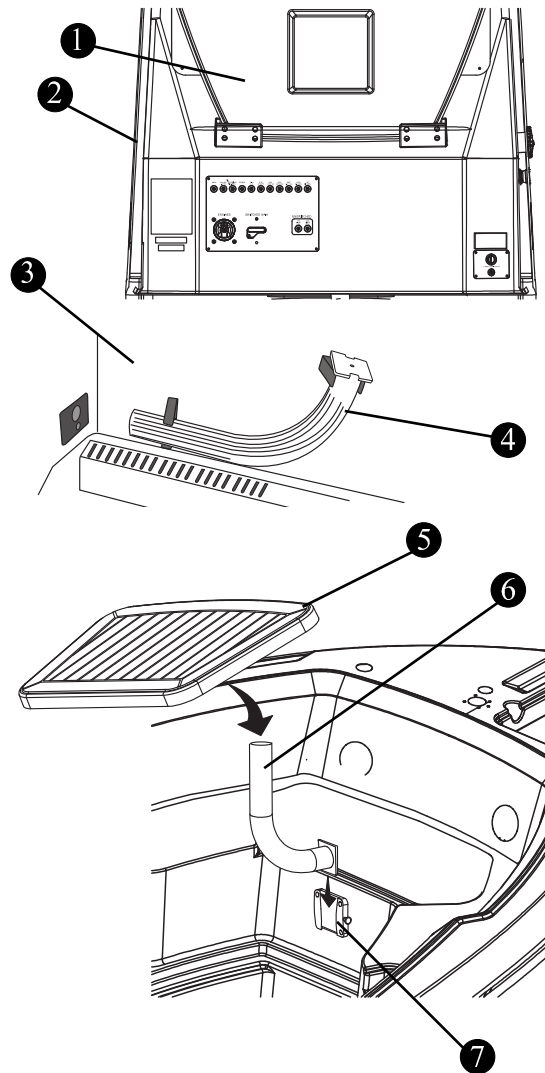

- ① BOW TABLE (STOWED)
- ② AFT WALL OF CONSOLE INTERIOR
- ③ PORT WALL OF CONSOLE INTERIOR
- ④ TABLE STAND PIPE (STOWED)
- ⑤ BOW TABLE
- ⑥ TABLE STAND PIPE
- ⑦ STAND PIPE RECEIVER PLATE

Retractable Swim Ladder

⚠ DANGER

To avoid risk of injury or death, shut off engines when near swimmers or prior to using swim ladder.

To deploy the transom ladder:

- Remove the bungee strap.

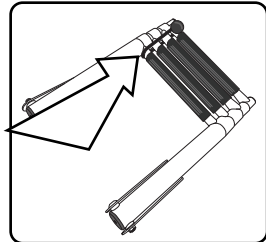

- Lift and rotate the ladder toward the aft of the boat.

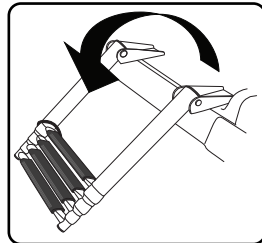

- Extend the ladder to its full length.

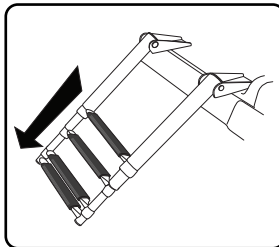

When not in use your swim ladder should be retracted and secured. To secure the ladder reverse the deployment method shown above.

Anchor Windlass (Option)

NOTICE

Be sure to read and fully understand the anchor windlass owner's manual before operating the anchor windlass.

The optional anchor windlass located at the bow of your boat facilitates the anchoring of your boat by automatically raising and lowering the anchor. The windlass can be operated from the helm; from the bow with remote control; or manually.

Operating The Windlass From the Helm

The anchor windlass is powered, at the helm, by switches on the windlass control panel.

Anchor Windlass (Option)

Fig. 3.17.1

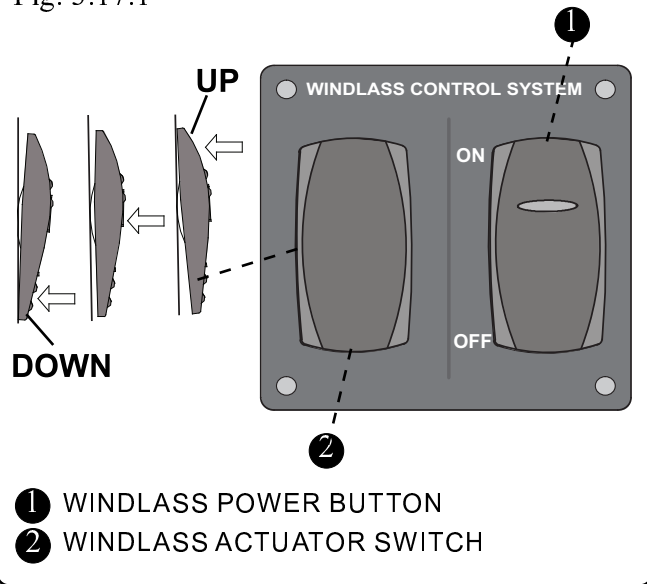

Activation of the windlass is controlled by a switch located to the left of the power switch. The activation switch is a momentary type switch, which means that there must be constant pressure applied to operate the anchor windlass and raise or lower the anchor.

NOTICE

Before operating the windlass be sure that the safety lanyard is removed from the anchor chain and is clear of the rode as it plays out or is retrieved.

Lowering the Anchor

Pushing the bottom of the actuator switch will power the anchor windlass DOWN. Make certain that the anchor safety lanyard is detached from the chain and is clear of any moving parts of the anchor windlass.

Raising the Anchor

Pushing the top of the actuator switch will power the anchor windlass UP. Once the anchor and rode is secure in the UP position, the anchor safety lanyard can be re-attached to the rode.

Operating The Windlass With Remote

⚠ DANGER

Use the anchor windlass switch on the helm when possible. Use care when operating the anchor windlass with the hand-held remote.

The anchor windlass can be operated from the bow with the use of the windlass remote which is stowed in the bow locker.

Remote Operation

NOTICE

Before operating the windlass be sure that the safety lanyard is removed from the anchor chain and is clear of the rode as it plays out or is retrieved.

⚠ WARNING

Keep hands, feet, hair and loose clothing clear of moving parts. Entanglement may cause severe bodily injury (i.e. lose of fingers or toes).

Anchor Windlass Remote (Option)

Fig. 3.17.2

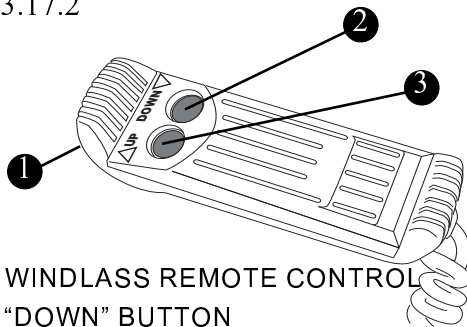

- ① WINDLASS REMOTE CONTROL
- ② "DOWN" BUTTON
- ③ "UP" BUTTON

- Plug the power cable into the power receptacle on the starboard side of the bow locker (Figure 3.32.1)

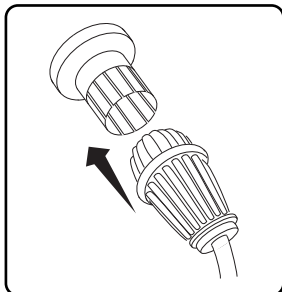

- Turn the forward portion of the plug clockwise to lock.

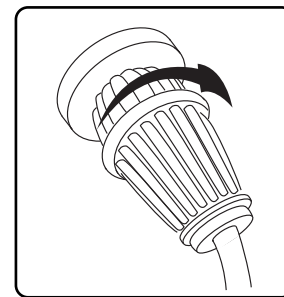

- To raise the anchor, press and hold on the "UP" button of the remote.

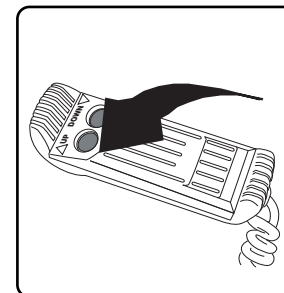

- To lower the anchor, press and hold on the "DOWN" button on the remote.

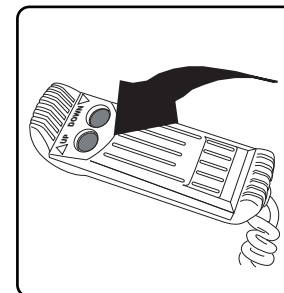

If there is a loss of power to the windlass, check the circuit breaker located behind the battery switch panel located on the aft wall of the cockpit interior (See figure 2.13.1). If the breaker is tripped, reset the breaker. If the breaker continues to trip, have the anchor windlass system checked by a qualified marine electrician.

Operating The Windlass Manually

In the event that there is a loss of power to the windlass the anchor can be raised and/or lowered manually by using the emergency handle located in the bow locker.

There are two star sockets on the top of the windlass used for manual deployment of the anchor (See figure 3.19.1). Inserting the emergency handle into the center socket and turning it counter-clockwise

Windlass Manual/Emergency Operation
Fig. 3.19.1

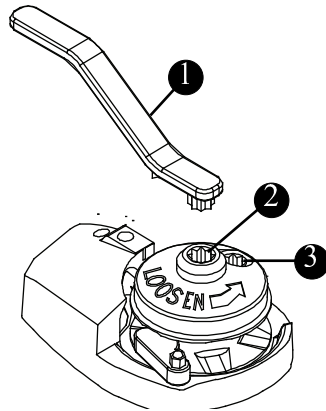

- ① EMERGENCY HANDLE
- ② LOOSEN WINDLASS
- ③ RAISE/LOWER ANCHOR

will loosen the anchor windlass chainwheel. The star socket located off-center is used for retrieving and lowering the anchor. Turning the handle counterclockwise will allow you to lower the anchor, while turning it clockwise will raise it.

When operation is complete, insert the handle into the center star socket and tighten the windlass chainwheel by rotating the handle clockwise. Be sure to attach the safety lanyard when the anchor is stowed in the bow pulpit.

REFER TO THE MANUFACTURER'S MANUAL IN YOUR OWNER'S MANUAL PACKET FOR COMPLETE INSTRUCTIONS.

Anchoring

The 230 Outrage is equipped with an anchor storage compartment located in the bow of the boat. Because there are a variety of anchors, with a variety of uses, **discuss the types of anchors with your dealer to find the right anchor for your boat.**

NOTICE

Before using the anchor be sure the anchor line is secured to the eye in the bottom of the anchor locker.

⚠ WARNING

SWAMPING HAZARD - Anchor from the bow if using one anchor. A small current can make a stern anchored boat unsteady. A heavy current can drag a stern anchored boat underwater.

Considerations

- Wind and sea conditions can affect the boat.
- Because the boat is not moving through the water, there is no control.
- Be sure that the anchor will hold under all circumstances if you are leaving the boat.
- Understand the principles of rode and scope and their effect on anchor performance.

Proper anchoring requires knowledge of RODE and SCOPE and understanding the relationship between rode, scope and anchor performance.

The rode is the line connecting the anchor to the boat. Nylon line is ideal because it is light, strong and stretches, it also can be stored wet and is easy to handle. Add a length of chain between the anchor and the nylon line to prevent abrasion of the line.

The scope is technically defined as the ratio of rode length to the vertical distance from the bow to the sea floor. Scope also depends on the type of anchor, tides, winds, sea conditions and type of sea floor the anchor is in. Since you want to know how much rode to use when anchoring, use this common formula:

Rode length = (bow height + water depth) X Scope

Example:

$$\text{Rode length} = (3 \text{ feet} + 10 \text{ feet}) \times 7^*$$

$$\text{Rode length} = 13 \text{ feet} \times 7^*$$

$$\text{Rode length} = 91 \text{ feet}$$

* Scope may range from 5 to 10 or more. However, less than 5, the anchor will break out too easily.

Proper anchoring requires knowledge of RODE and SCOPE and understanding the relationship between rode, scope and anchor performance.

The rode is the line connecting the anchor to the boat. Nylon line is ideal because it is light, strong and stretches, it also can be stored wet and is easy to handle. Add a length of chain between the anchor and the nylon line to prevent abrasion of the line.

Section 3 • Systems & Components Overview & Operation

The scope is technically defined as the ratio of rode length to the vertical distance from the bow to the sea floor. Scope also depends on the type of anchor, tides, winds, sea conditions and type of sea floor the anchor is in. Since you want to know how much rode to use when anchoring, use this common formula:

Rode length = (bow height + water depth) X Scope

The minimum is 5:1 for calm conditions; normal is 7:1, and severe conditions may require a 10:1.

Lowering The Anchor

- Stop completely before lowering the anchor.
- Be sure there is adequate rode.
- Secure rode to both the anchor and the boat.
- Keep feet clear of lines.
- Turn on the anchor light when at anchor or drifting (not under power) at night or in low visibility.

Setting the Anchor

There is no best way to set an anchor. Experiment to see how it performs. One method is to turn the rode around a bitt or a cleat and slowly pay out as the boat backs from the anchor site. When the proper scope has been reached snub the rode quickly, causing the anchor to dig in to the sea bottom.

- Reverse the engine slowly to drive the anchor in and to prevent it from dragging.
- Secure the rode to the bitt or cleat.

Weighing the Anchor

To weigh (or retrieve) the anchor, start the boat and run slowly up to the anchor, taking up the rode as you go. The anchor will usually break out when the rode becomes vertical. Coil lines to let them dry before stowing.



CAUTION

Be careful that the trailing lines do not foul in the propeller

Proper Anchoring
Fig. 3.20.1

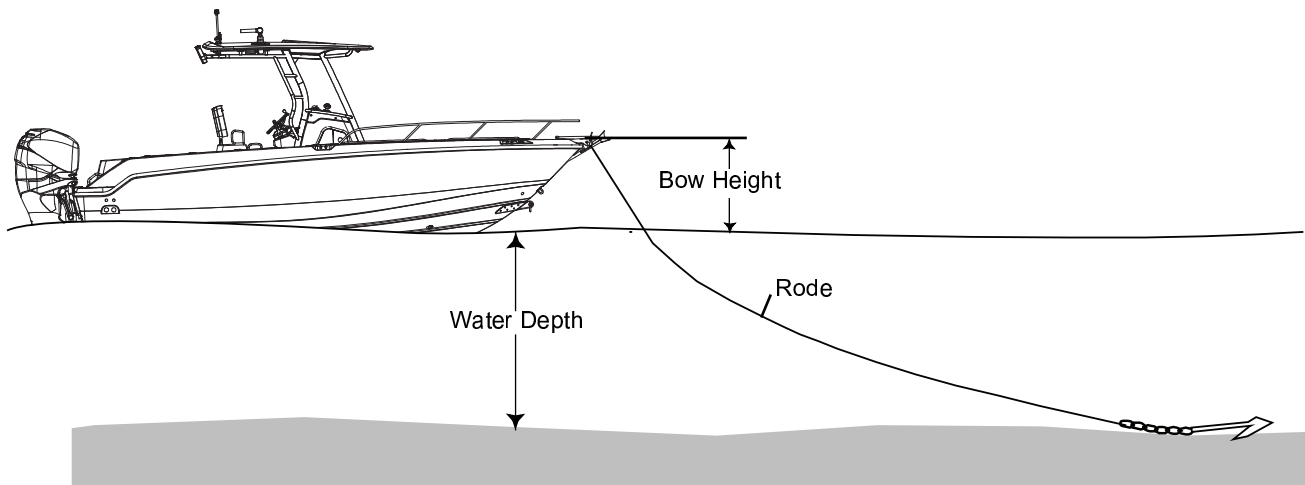

Rode length = (bow height + water depth) X Scope

Section 4 • Electrical System

DC Electrical System

The DC electrical system on the 230 Outrage is powered by two (2) batteries. The batteries are charged by the engines when the engines are running or by shore power when connected. The batteries power essential systems on your boat:

- Engine Ignition.
- Engine tilt trim system
- Helm switch panel & helm instrument panel
- Navigation Lighting system
- Livewell system
- Electronics and add-on accessories
- Lighting

Batteries

NOTICE

Always store the batteries in the battery trays. Use the retaining lid and wingnuts to keep the batteries secure while underway.

NOTICE

REFER TO YOUR ENGINE OWNER'S MANUAL FOR EXACT BATTERY REQUIREMENTS.

The chart below is provided for reference purposes only. Use **only AGM batteries with Verado engines.**

Application	Group	Volts	MCA*	RC 25	Qty.
USA (SAE)	31	12	800	135 min	2**

* Marine Cranking Amps

** Dual engine option requires a third battery

Application	Group	Volts	CCA*	Reserve	Qty.
Intn'l (EN)	31	12	975	65Ah	2**

* Cold Cranking Amps

** Dual engine option requires a third battery

NOTICE

Ensure that your batteries meet Mercury's AGM & CCA requirements

Battery Trays

The Battery Trays located forward in the console interior house secure the batteries (Figure 4.1.1). The batteries can be installed or removed by loosening

the wing nuts and removing the retaining bar on the battery tray.

Battery Trays (Dual Engine Option)

If your boat is equipped with the dual engine option a third battery will be located in the forward section of the console interior. The additional battery powers the port engine.

Battery Care

Your batteries should always be enclosed in the battery trays provided with your boat and secured in place by the retaining bar. This will ensure that while underway the batteries will not move around, thus causing damage to components fitted in the same area.

Before use, check each battery and the charging system for loose connections or wiring. Normal maintenance should include:

- Coating the terminals with dielectric grease
- Keeping the batteries dry

Battery Trays

Fig.4.1.1

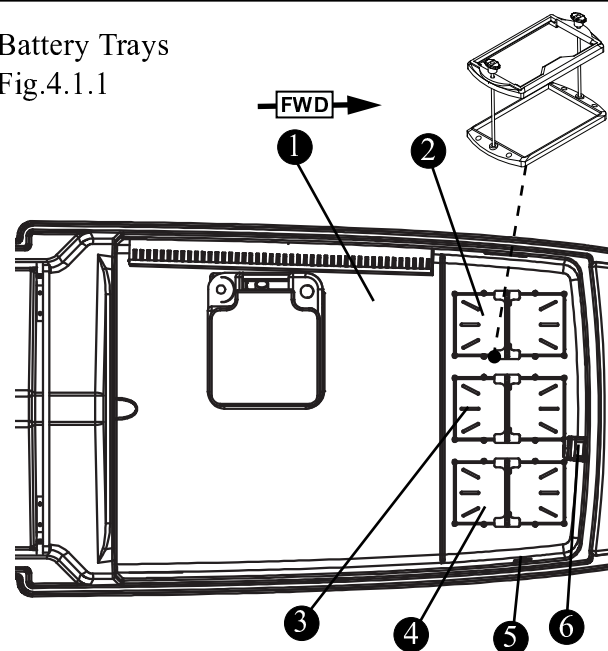

- 1 FORWARD CONSOLE INTERIOR
- 2 PORT ENGINE BATTERY (OPTION)
- 3 HOUSE BATTERY
- 4 STARBOARD (SINGLE ENGINE) BATTERY
- 5 HOUSE MAIN BREAKER
- 6 VSR (VOLTAGE SENSITIVE RELAY)

Section 4 • Electrical System

- If not using a sealed battery, check & maintain the water level. USE DISTILLED WATER ONLY.
- Removing the batteries from the boat during cold weather or long term storage.

The most life shortening experience for the battery is to be drained to zero charge before recharging.

When a battery discharges, the active material on both positive and negative plates converts to lead sulfate, causing the plates to become more alike in an electrical charge. The electricity conducting battery acid becomes weaker and the voltage drops. As the battery remains discharged, the process continues until recharging the battery becomes impossible.

If the battery does become run down be sure to recharge it as soon as possible. Overcharging the battery can be just as detrimental to its life as running it down too far.

DANGER

Batteries contain sulfuric acid which is dangerous and can cause serious injury. AVOID contact with skin, eyes and clothing. If contact occurs, immediately flush the affected area with large quantities of water and call for medical assistance.

NOTICE

The Bilge pump, stereo memory, battery charger and clean power for the DTS system still draw power from the house battery even if the switch is set to "OFF".

Battery Switches

Your 230 Outrage uses a battery selector switch to control delivery of DC power from the two batteries. The battery switch is located on a panel on the aft wall of the console interior (See fig. 4.3.1).

The battery switch has two (2) settings, OFF and ON.

- “OFF” - you will have no power to the engines.

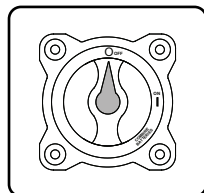

- “ON” - you will have power to the engine(s) as well as all essential boat systems.

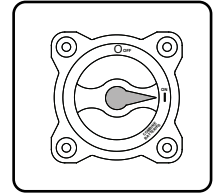

House Main Breaker

The house main breaker located forward of the battery trays in the console interior (see fig. 4.1.1) must be turned ON to provide power to all non-essential vessel components.

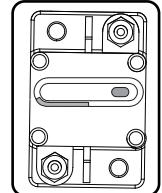

CAUTION

- **NEVER use an open flame in the battery storage area.**
- **Avoid striking sparks near the battery.**
- **A battery will explode if a flame or spark ignites the free hydrogen given off during charging.**
- **ALWAYS disconnect the battery before doing any work or maintenance on the electrical system.**
- **NEVER turn off the battery switches or disconnect the battery cables while the**

12 Volt Accessory Receptacle

NOTICE

DO NOT insert a cigarette lighter into this receptacle. Damage to the unit & system could occur.

Your 230 Outrage is equipped with a 12 volt accessory receptacle located on the helm switch panel (See fig. 2.10.1). The DC receptacle is to be used with any 12 volt accessories using this style of plug.

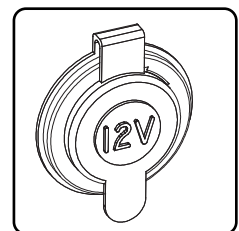

There is a 10 amp breaker located on the breaker panel (labeled “ACC”) (See figure 4.3.1). **Be sure to use accessories that do not exceed the rated capacity of the circuit, (10 amps) or the breaker will trip.**

Section 4 • Electrical System

Component Breaker Panel - Single Engine

Fig. 4.3.1

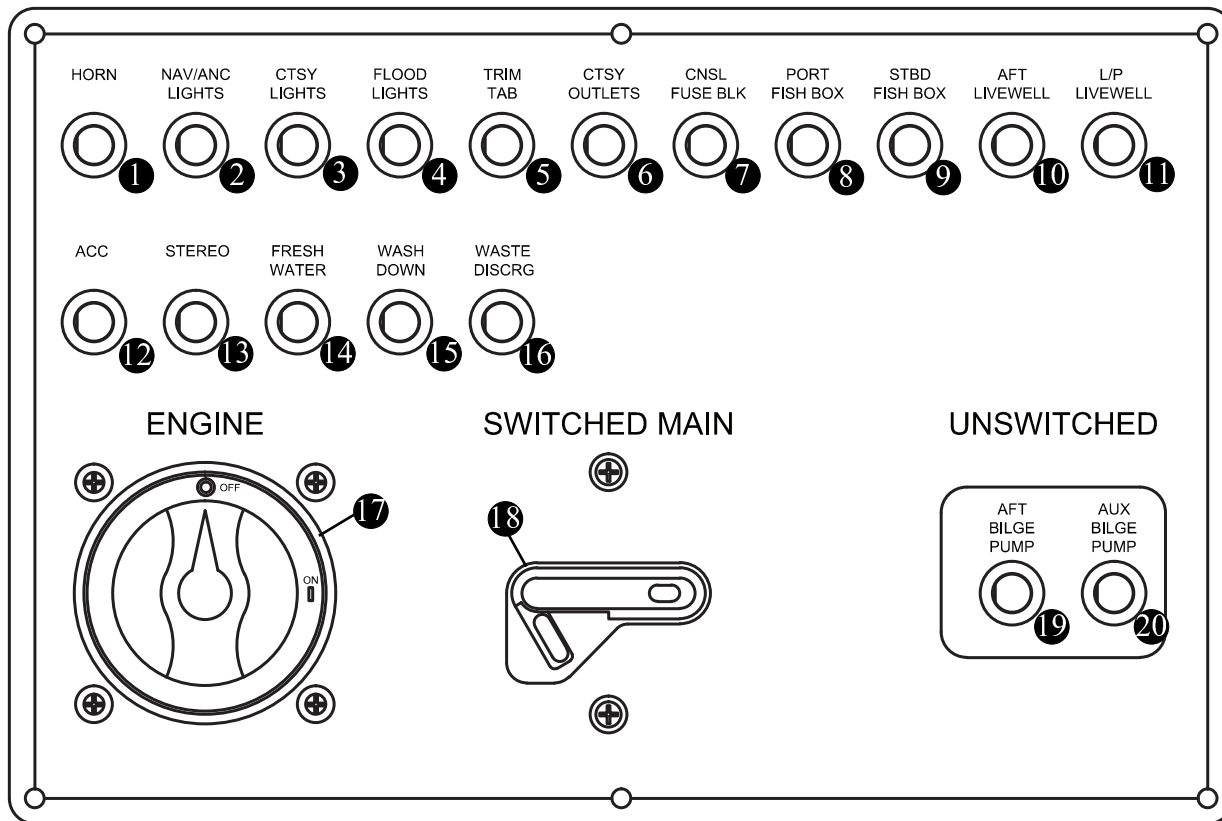

- | | | |
|---|--------------------------------------|---------|
| ① | HORN | 10 AMP |
| ② | NAV/ANCH LIGHTS..... | 10 AMP |
| ③ | COURTESY/MAP LIGHTS..... | 10 AMP |
| ④ | FLOOD LIGHT | 10 AMP |
| ⑤ | TRIM TAB | 20 AMP |
| ⑥ | COURTESY OUTLETS | 15 AMP |
| ⑦ | CONSOLE FUSE BLOCK | 40 AMP |
| ⑧ | PORT FISHBOX PUMP (OPTION)..... | 10 AMP |
| ⑨ | STARBOARD FISHBOX PUMP (OPTION)..... | 10 AMP |
| ⑩ | AFT LIVEWELL | 6 AMP |
| ⑪ | L/P LIVEWELL (OPTION)..... | 6 AMP |
| ⑫ | 12V RECEPTACLE | 15 AMP |
| ⑬ | STEREO (OPTION)..... | 15 AMP |
| ⑭ | FRESH WATER PUMP (OPTION)..... | 15 AMP |
| ⑮ | RAW WATER PUMP (OPTION)..... | 15 AMP |
| ⑯ | WASTE DISCHARGE PUMP (OPTION)..... | 25 AMP |
| ⑰ | BATTERY SWITCH | |
| ⑱ | MAIN BREAKER | 150 AMP |
| ⑲ | AFT BILGE PUMP | 6 AMP |
| ⑳ | AUX BILGE PUMP (OPTION)..... | 6 AMP |



CAUTION

NEVER reset a breaker without first determining and correcting the cause of the trip. Should a circuit breaker repeatedly trip, have a qualified electrician determine and correct the cause.

Section 4 • Electrical System

Component Breaker Panel - Dual Engine (Option)

Fig. 4.4.1

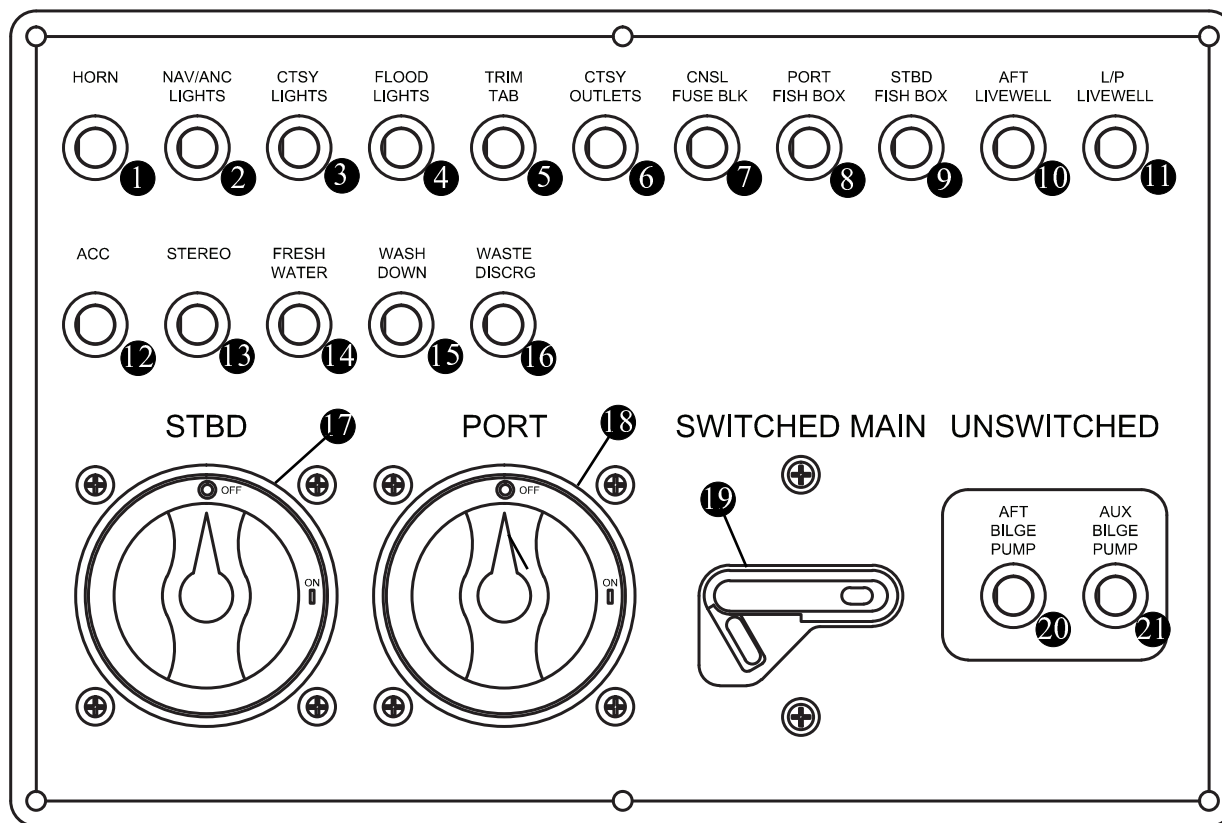

- | | |
|--|---------|
| ① HORN | 10 AMP |
| ② NAV/ANCH LIGHTS..... | 10 AMP |
| ③ COURTESY LIGHT | 10 AMP |
| ④ FLOOD LIGHT | 10 AMP |
| ⑤ TRIM TABS..... | 20 AMP |
| ⑥ COURTESY OUTLETS..... | 15 AMP |
| ⑦ CONSOLE FUSE BLOCK..... | 40 AMP |
| ⑧ PORT FISHBOX PUMP (OPTION)..... | 10 AMP |
| ⑨ STARBOARD FISHBOX PUMP (OPTION)..... | 10 AMP |
| ⑩ AFT LIVEWELL..... | 6 AMP |
| ⑪ L/P LIVEWELL (OPTION)..... | 6 AMP |
| ⑫ ACC..... | 10 AMP |
| ⑬ STEREO (OPTION) | 15 AMP |
| ⑭ FRESH WATER PUMP (OPTION)..... | 15 AMP |
| ⑮ WASHDOWN PUMP (OPTION)..... | 15 AMP |
| ⑯ WASTE DISCHARGE PUMP (OPTION)..... | 25 AMP |
| ⑰ STARBOARD ENGINE BATTERY SWITCH | |
| ⑱ PORT ENGINE BATTERY SWITCH | |
| ⑲ MAIN BREAKER..... | 150 AMP |
| ⑳ AFT BILGE PUMP | 6 AMP |
| ㉑ AUX BILGE PUMP..... | 6 AMP |



CAUTION

NEVER reset a breaker without first determining and correcting the cause of the trip. Should a circuit breaker repeatedly trip, have a qualified electrician determine and correct the cause.

Section 4 • Electrical System

Fuse Blocks

There is an electronics fuse block located in the console which can be accessed thru a panel on the aft wall of the console interior.

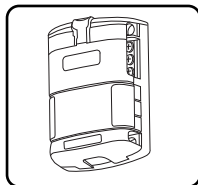

In the event you need to replace a fuse, use only the same amperage as the original. It is recommended that you carry spare fuses.

If a fuse is replaced with one of lower amperage, it will not be sufficient to carry the electrical load of the equipment it is connected to and will cause nuisance fuse failure or breaker tripping.

If a fuse is replaced with one of higher amperage, it will not provide adequate protection against an electrical malfunction and will create a fire hazard.

WARNING

Use of higher amperage fuses or breakers is a fire hazard.

Use fuses and breakers having the same amperage rating as the original or as specified.

Voltage Sensitive Relays (VSR)

The battery banks on your boat are automatically connected in parallel through the use of a VSR (Voltage Sensitive Relay) located on the forward wall of the console (Figure 4.5.1).

When a sufficient charging source is present. The battery banks are automatically separated when the charging source falls below a certain voltage level for a predetermined amount of time.

Voltage Sensitive Relays (VSR)

Fig.4.5.1

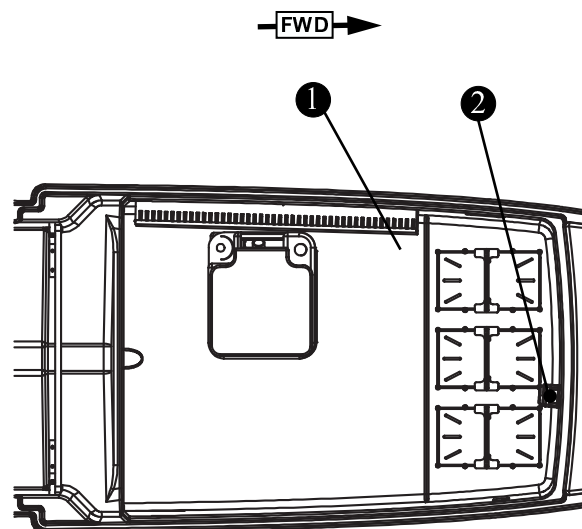

① CONSOLE INTERIOR

② VSR (VOLTAGE SENSITIVE RELAY)*

* Dual engine option requires two (2) VSR

The use of VSRs eliminates the need for the operator to monitor battery voltage and decide whether or not it is ok to parallel the battery banks. It also eliminates the chance of a dead battery bank if a paralleling switch were left in the "Combined" position without a sufficient charging source present.

REFER TO THE MANUFACTURER'S MANUAL IN YOUR OWNER'S MANUAL PACKET FOR COMPLETE INSTRUCTIONS, WARRANTY AND SAFETY INFORMATION.

Section 4 • Electrical System

Rigging

Your boat has a large open space between the fuel tank and the floor to run additional wiring. Feed the new runs through the rigging boots and secure it to the existing runs.

If equipped with the optional hardtop or T-top, additional wiring can be routed through the starboard aft support of the frame.

Tie another piece of nylon cord to the current accessory wiring being run and use that for later runs.

Rigging
Fig. 4.6.1

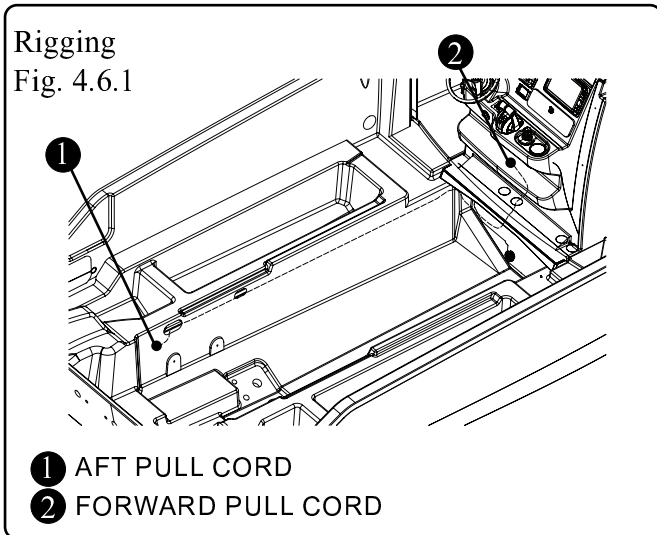

Hardtop/T-top Rigging
Fig. 4.6.2

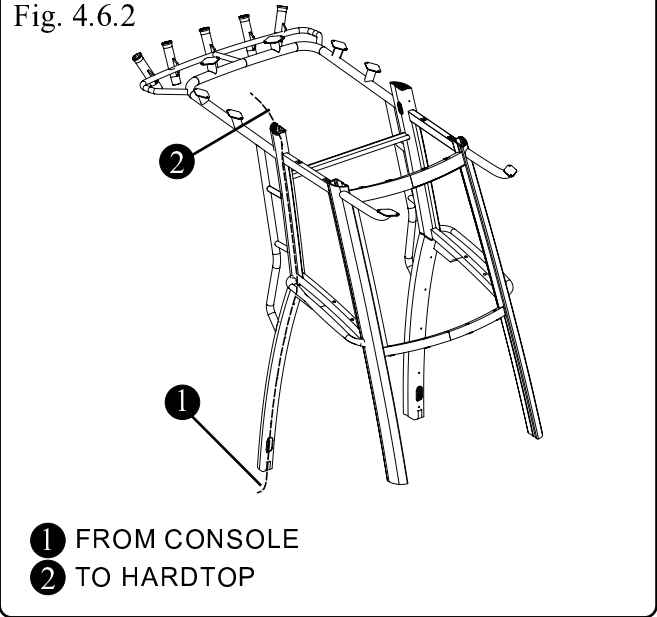

Section 4 • Electrical System

Electrical Schematics

The schematics & diagrams on the following pages were generated by technicians in the Boston Whaler® Engineering Department and are for reference, to be used by service technicians.

Boston Whaler® does not recommend that you attempt to work on the electrical system yourself. Instead, we suggest that you take your boat to an authorized Boston Whaler® dealer for electrical service.

Boston Whaler® reserves the right to change or update the electrical system on any model at any time without notice to the customer and is not obligated to make any updates to units built prior to the change.

Wiring Identification Chart

Boston Whaler® adheres to electrical wiring requirements which meet all the ABYC E-11 standards. The following chart outlines the gauge, color and function of the wiring used.

Wire Color Chart for DC and Special Circuit

COLOR	FUNCTION	COLOR	FUNCTION
GRN	GROUNDING MAIN/TOWER & ALUMINUM FUEL TANKS	BRN/ORN	SUMP PUMP
GRN	GROUNDING	BRN/RED	BILGE PUMP (UNSWITCHED)
ORN	STARBOARD 30 AMP RECEPTACLE	BRN/WHT	MACERATOR
RED	MAIN FEEDS/PORT 30 AMP RECEPTACLE	GRY	RUNNING LIGHTS
BRN/BLK	STARBOARD FISHBOX PUMP	GRY/BLK	ACC 1
BRN/VIO	FORWARD FISHBOX PUMP	GRY/BLU	ACC 2
BRN/YEL	LIVEWELL PUMP (HIGH CURRENT)	GRY/GRN	ACC 3
BRN/BLU	PORT FISHBOX PUMP	GRY/RED	AFT MAST/ACC 4
RED	+12V MAIN	GRY/WHT	ALL ROUND/FWD MAST LIGHT
BLK	GROUND	ORN	REFRIGERATOR or CENTER WIPER
BLK/YEL	STOP CIRCUIT	ORN/BLU	HORN
BLK/WHT	GEN SHUTDOWN	ORN/BRN	STARBOARD WIPER PARK
BLU	COMPASS	ORN/GRN	STARBOARD WIPER
BLU/BLK	DOME LIGHT	ORN/RED	PORT WIPER
BLU/GRN	SPREADER LIGHT	ORN/VIO	VACUUM PUMP
BLU/ORN	LIVEWELL LIGHT	ORN/WHT	CENTER WIPER
BLU/RED	COURTESY LIGHTS	PINK	FUEL SENDER
BLU/VIO	CABIN LIGHTS	RED	12V RECEPTACLE
BRN	BILGE PUMP (SWITCHED)	VIO	IGNITION
BRN/GRY	RAW WATER	WHT	CO MONITOR/ELECTRIC TRIM TAB (SWITCHED)
BRN/GRN	FRESH WATER	YLW	BLOWER/STEREO MEMORY START
		YLW/RED	

Section 4 • Electrical System

230 Outrage Schematic- Sheet 1
Fig. 4.8.1

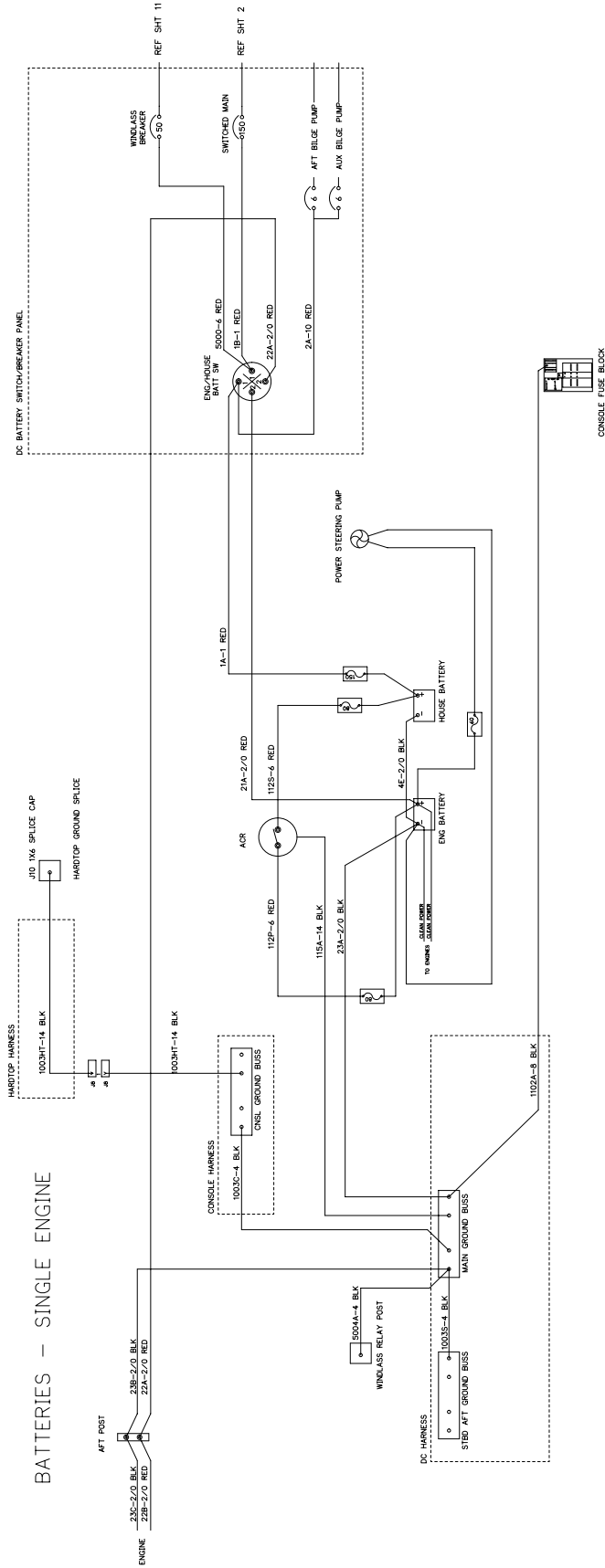

Section 4 • Electrical System

230 Outrage Schematic- Sheet 2

Fig. 4.9.1

DC BATTERY SWITCH/BREAKER PANEL SINGLE ENGINE

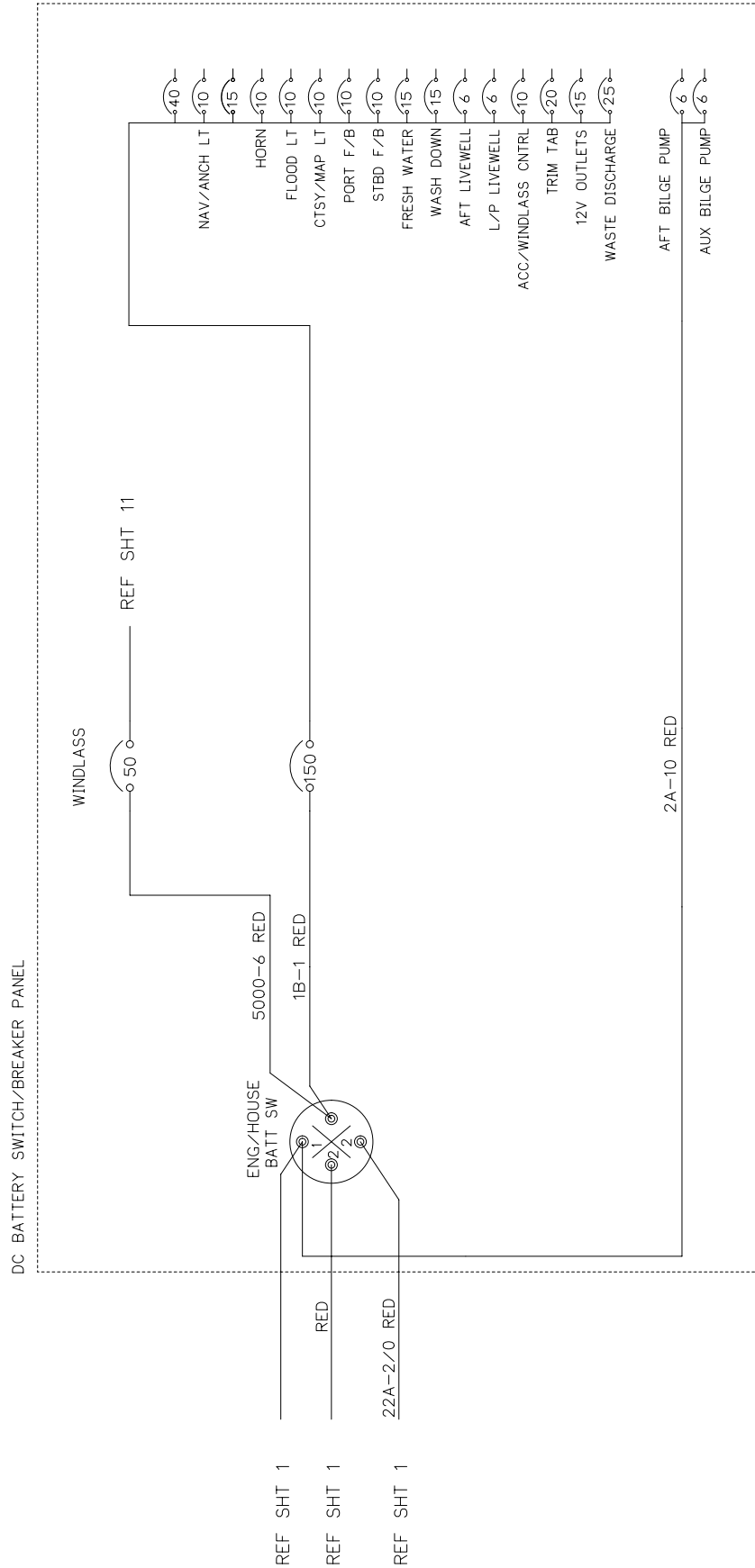

Section 4 • Electrical System

230 Outrage Schematic- Sheet 4
Fig. 4.11.1

DC BATTERY SWITCH/BREAKER PANEL DUAL ENGINE

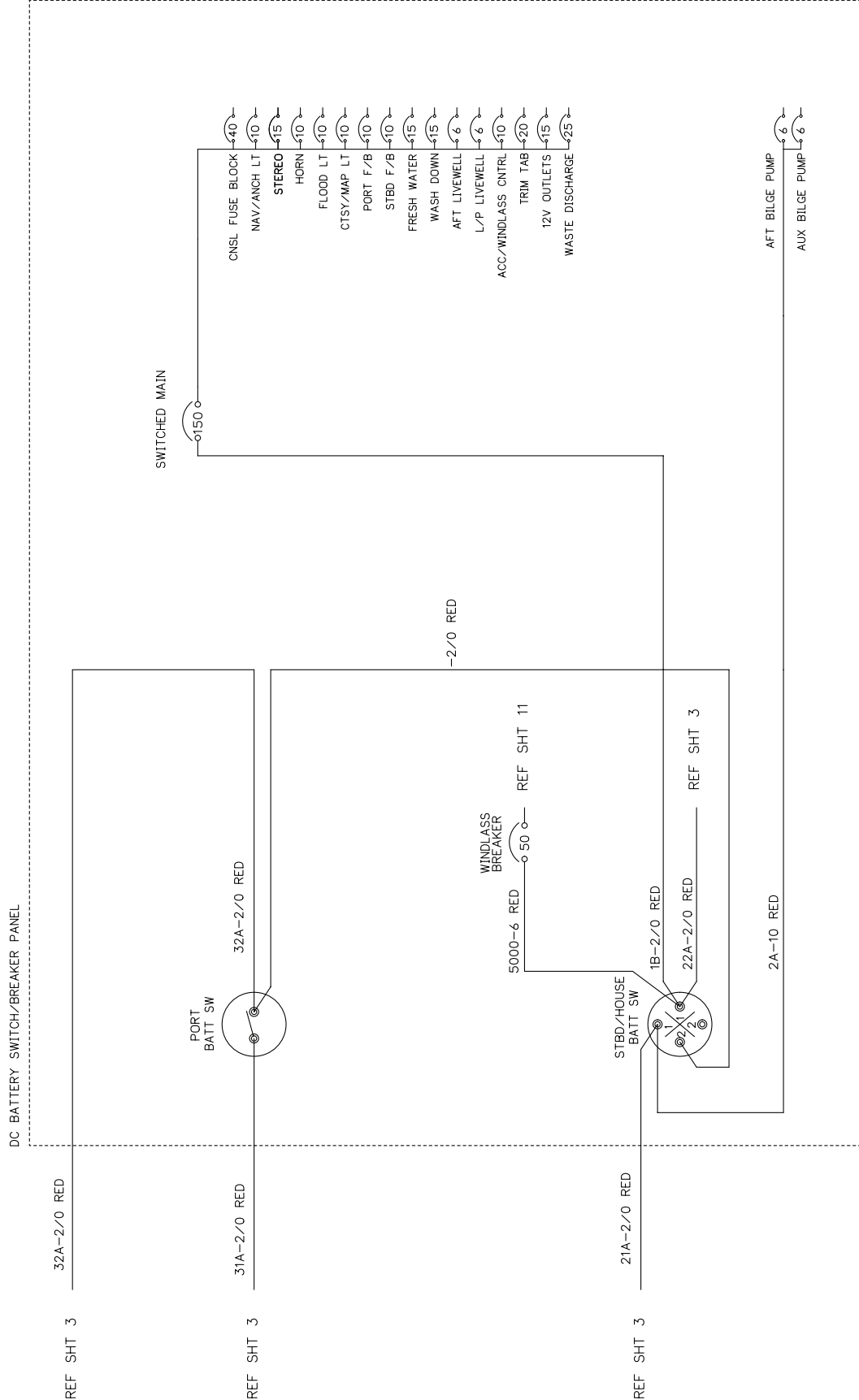

230 Outrage Schematic- Sheet 5
 Fig. 4.12.1

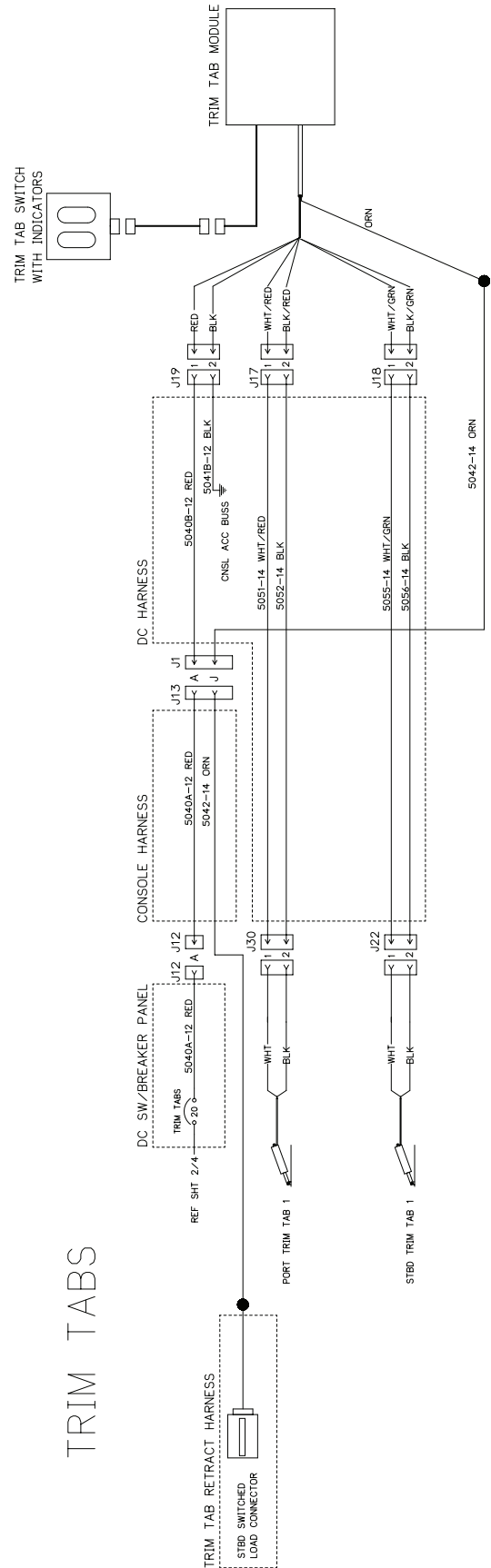

TRIM TABS

Section 4 • Electrical System

230 Outrage Schematic- Sheet 6
Fig. 4.13.1

CTSY LIGHT & DECK CTSY LIGHT

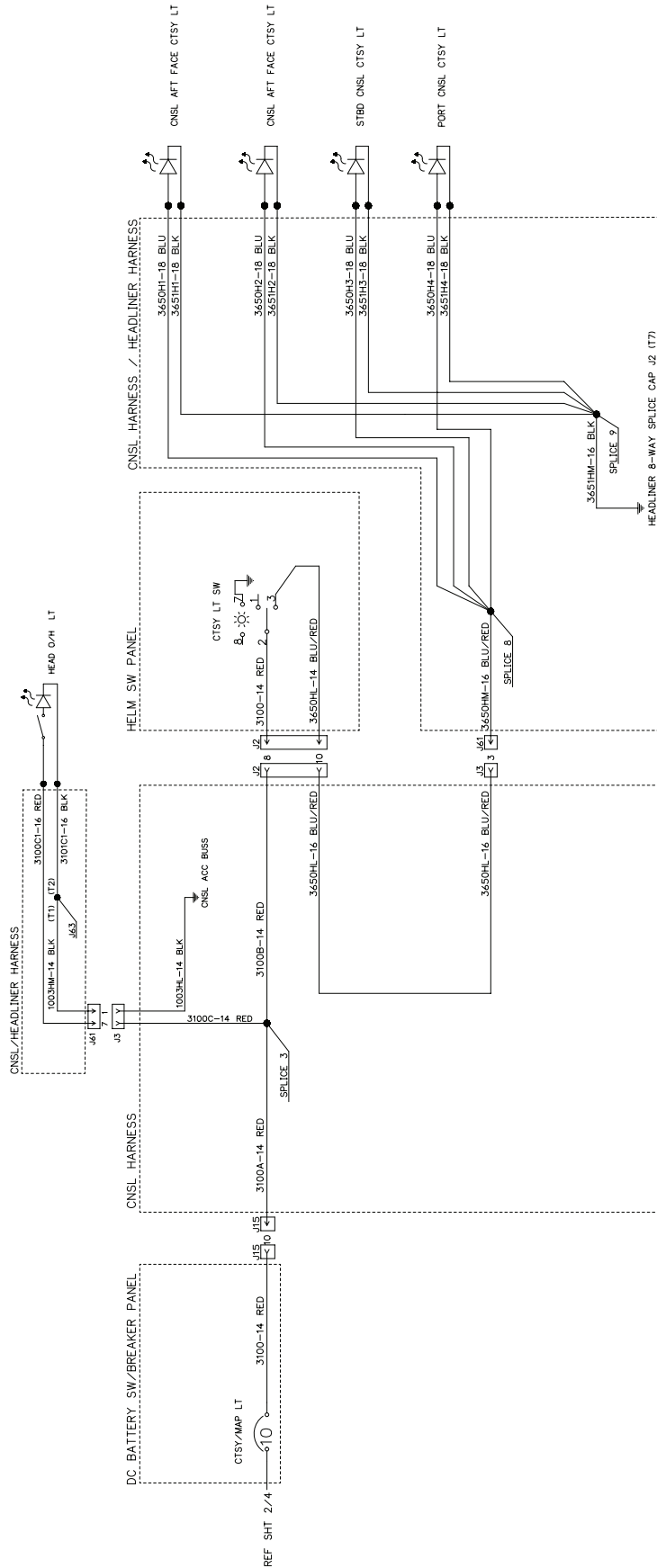

230 Outrage Schematic- Sheet 7
 Fig. 4.14.1

UNDERWATER LIGHT

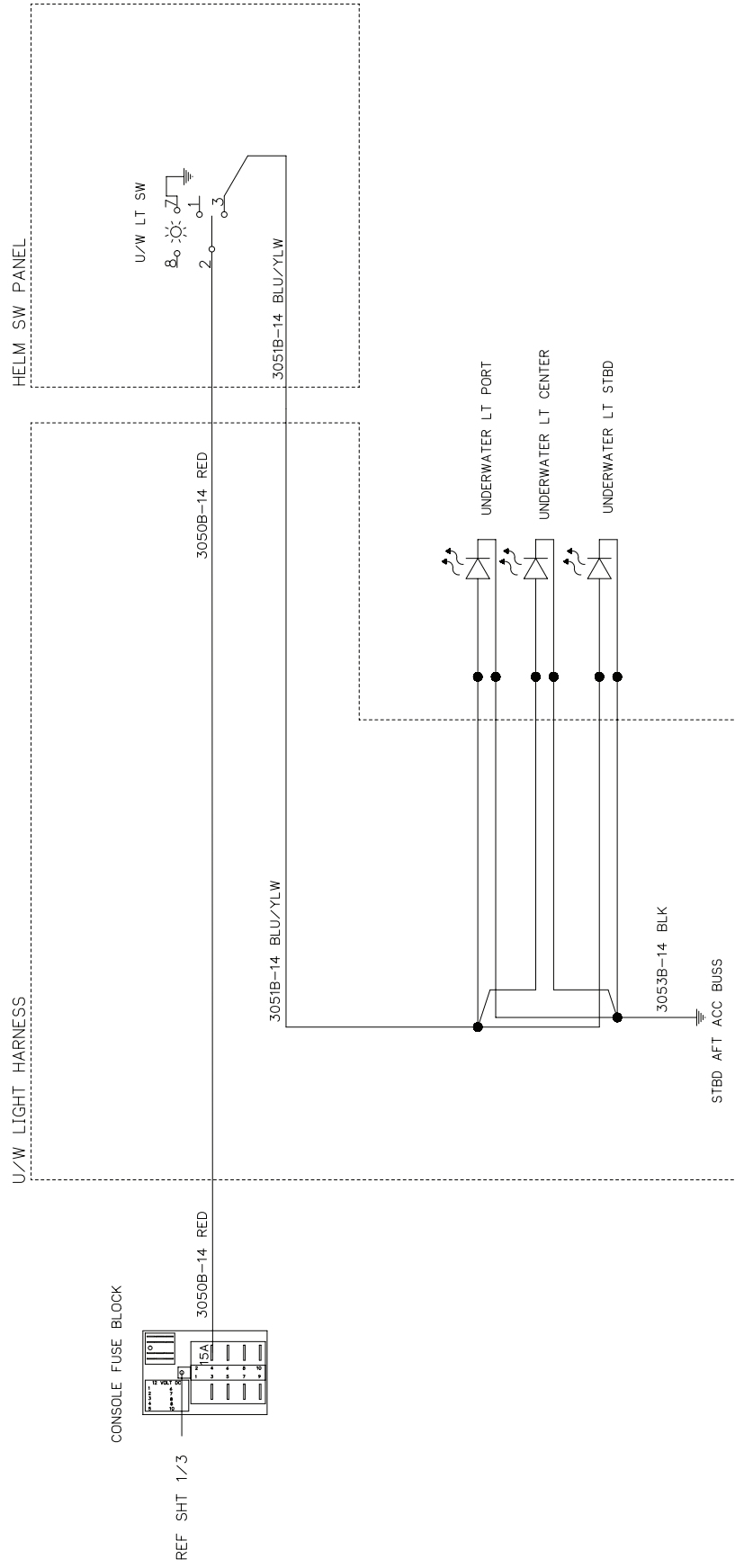

* NOTE *
 * THE CONSOLE FUSE BLOCK IS LOCATED INSIDE THE CONSOLE *

Section 4 • Electrical System

230 Outrage Schematic- Sheet 8
Fig. 4.15.1

NAV LIGHTING

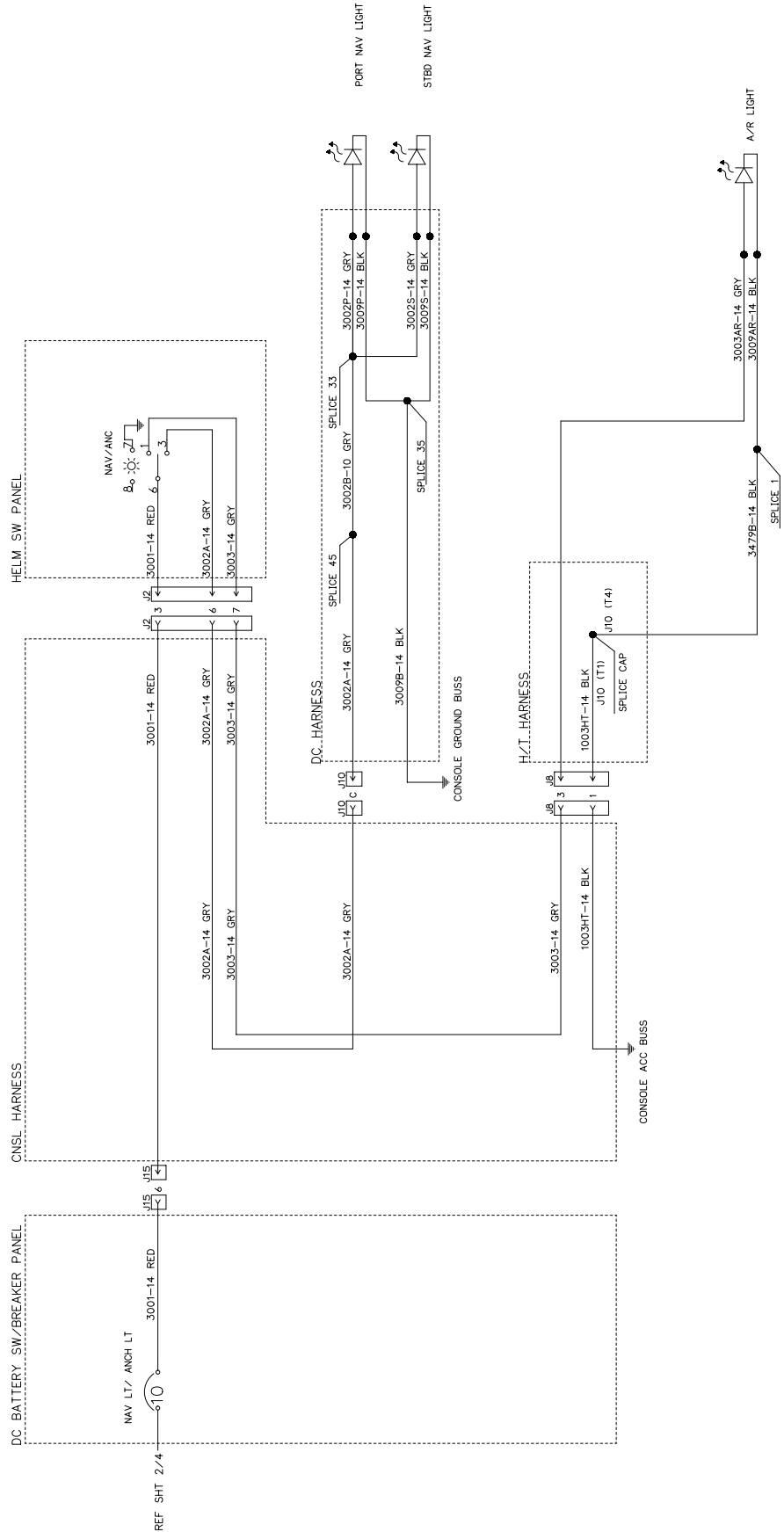

230 Outrage Schematic- Sheet 9
 Fig. 4.16.1

FLOOD LIGHTING

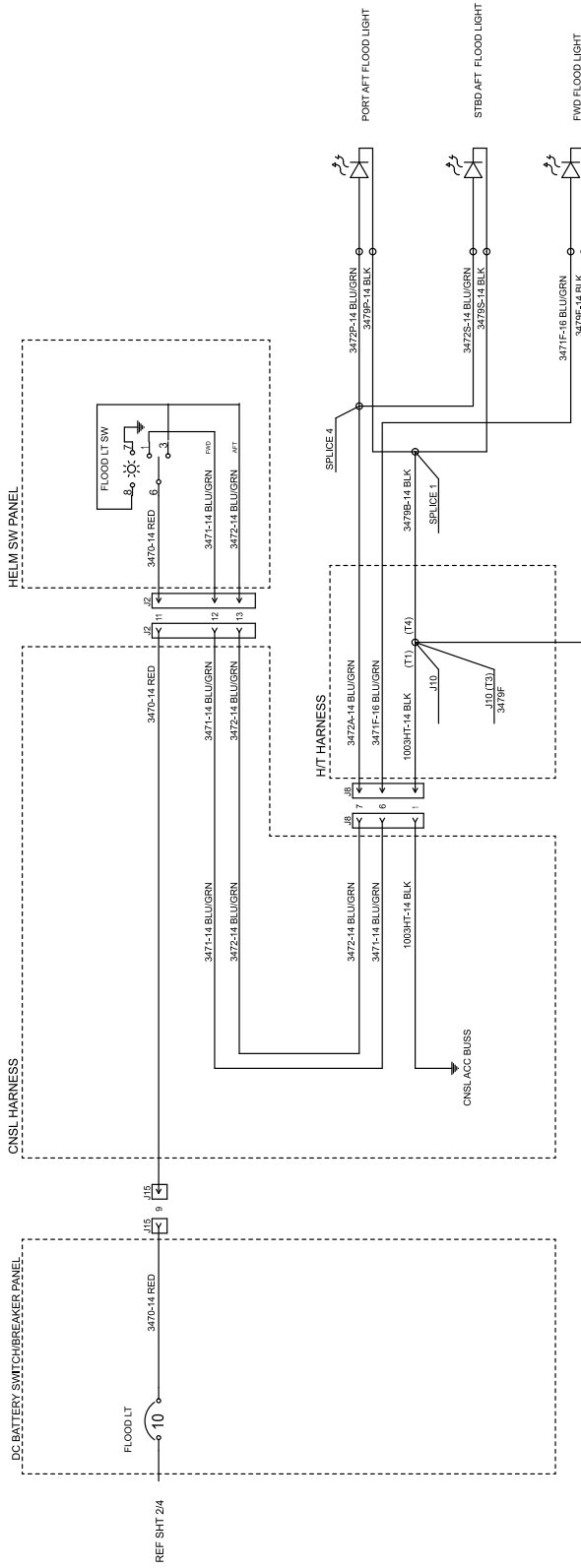

CTSY OUTLET

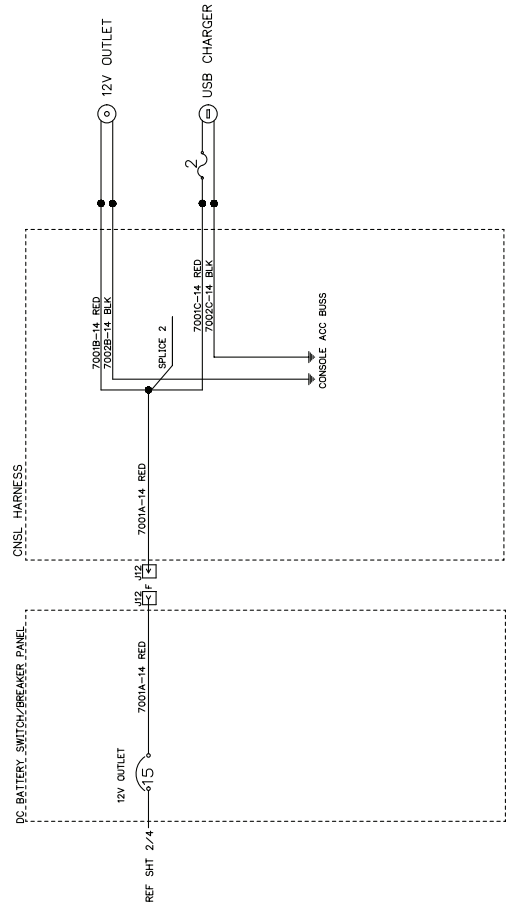

230 Outrage Schematic- Sheet 10

Fig. 4.17.1

HELM SWITCH PANEL

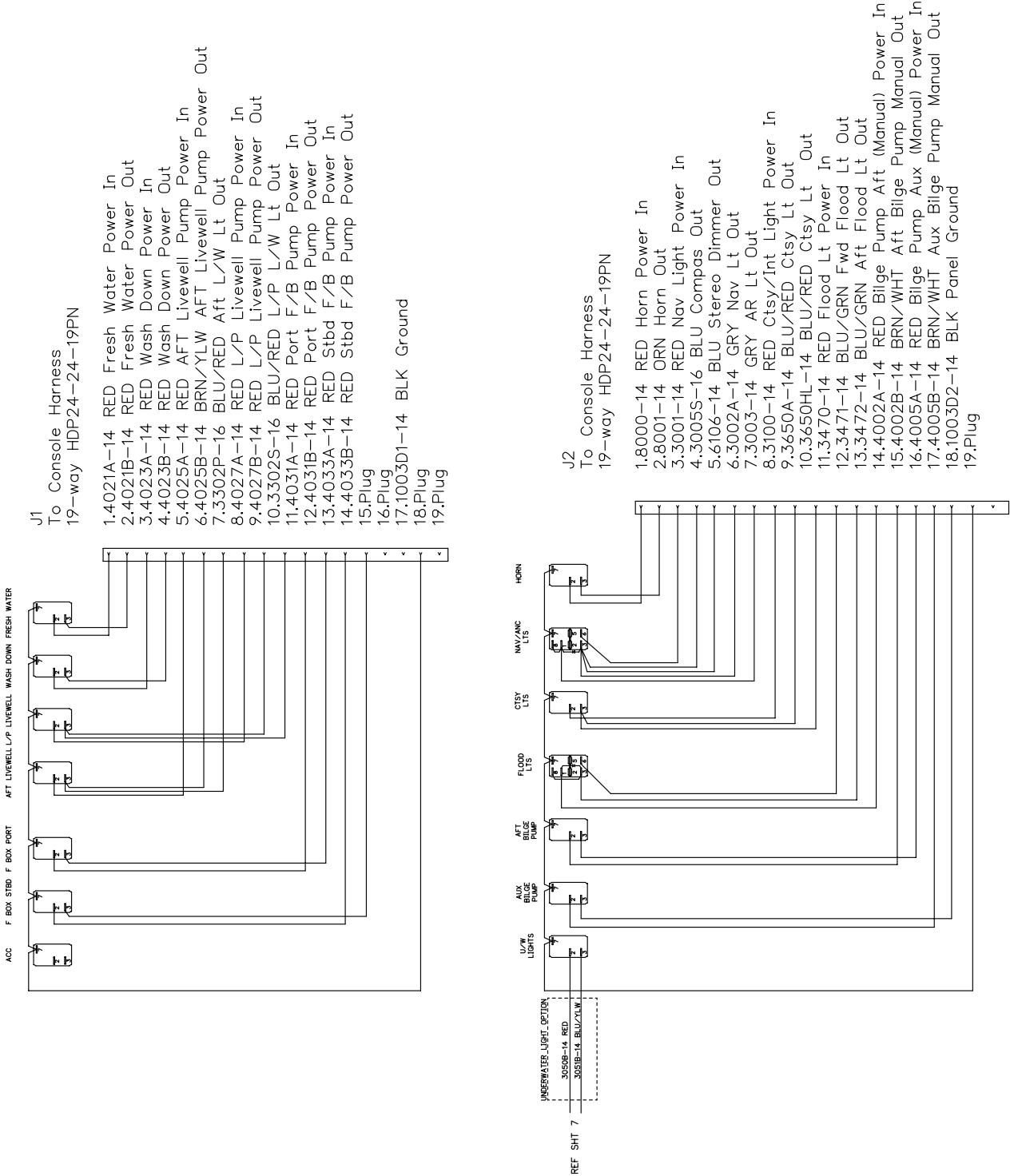

Section 4 • Electrical System

230 Outrage Schematic- Sheet 11
Fig. 4.18.1

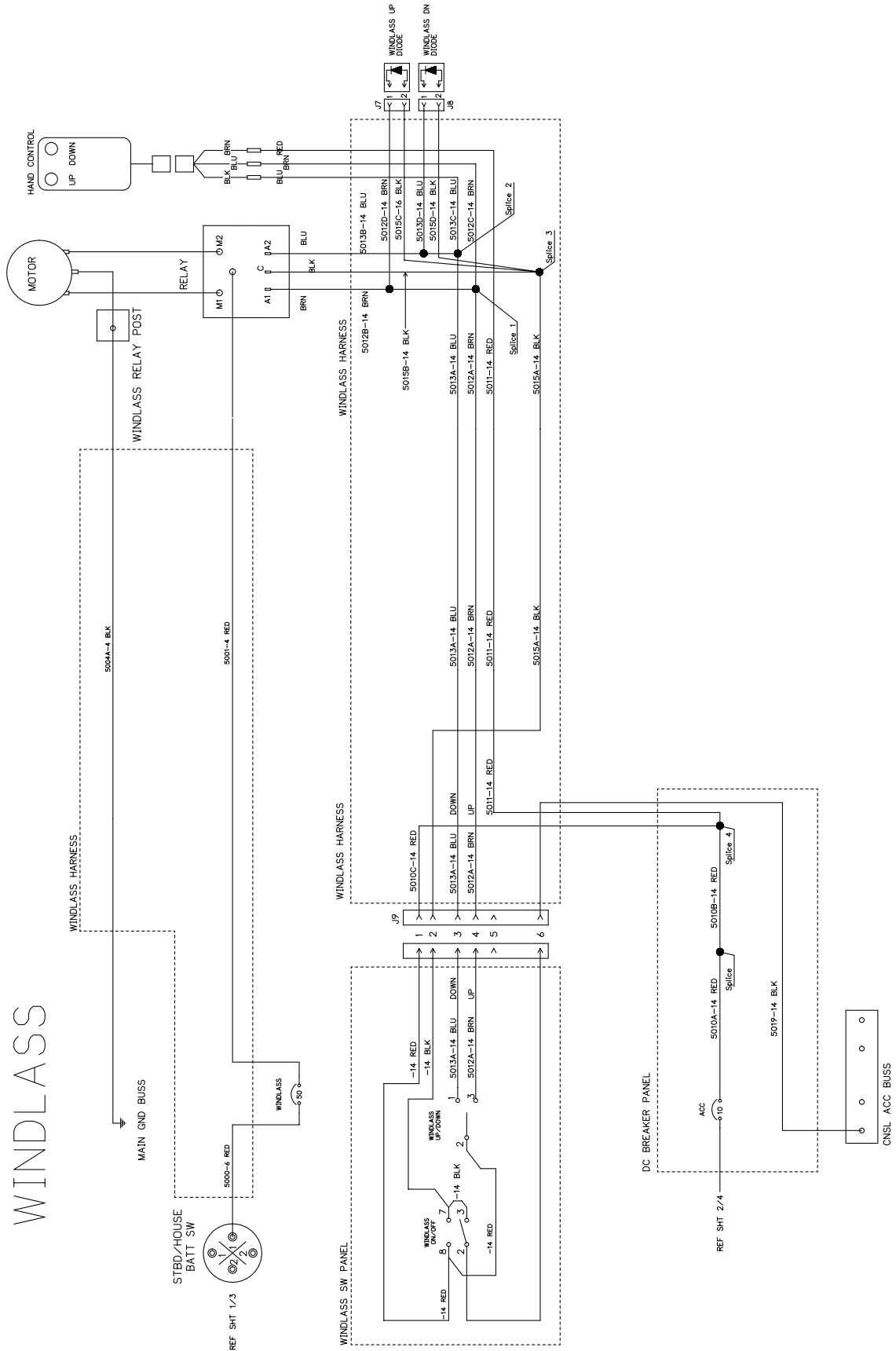

Section 4 • Electrical System

230 Outrage Schematic- Sheet 12

Fig. 4.19.1

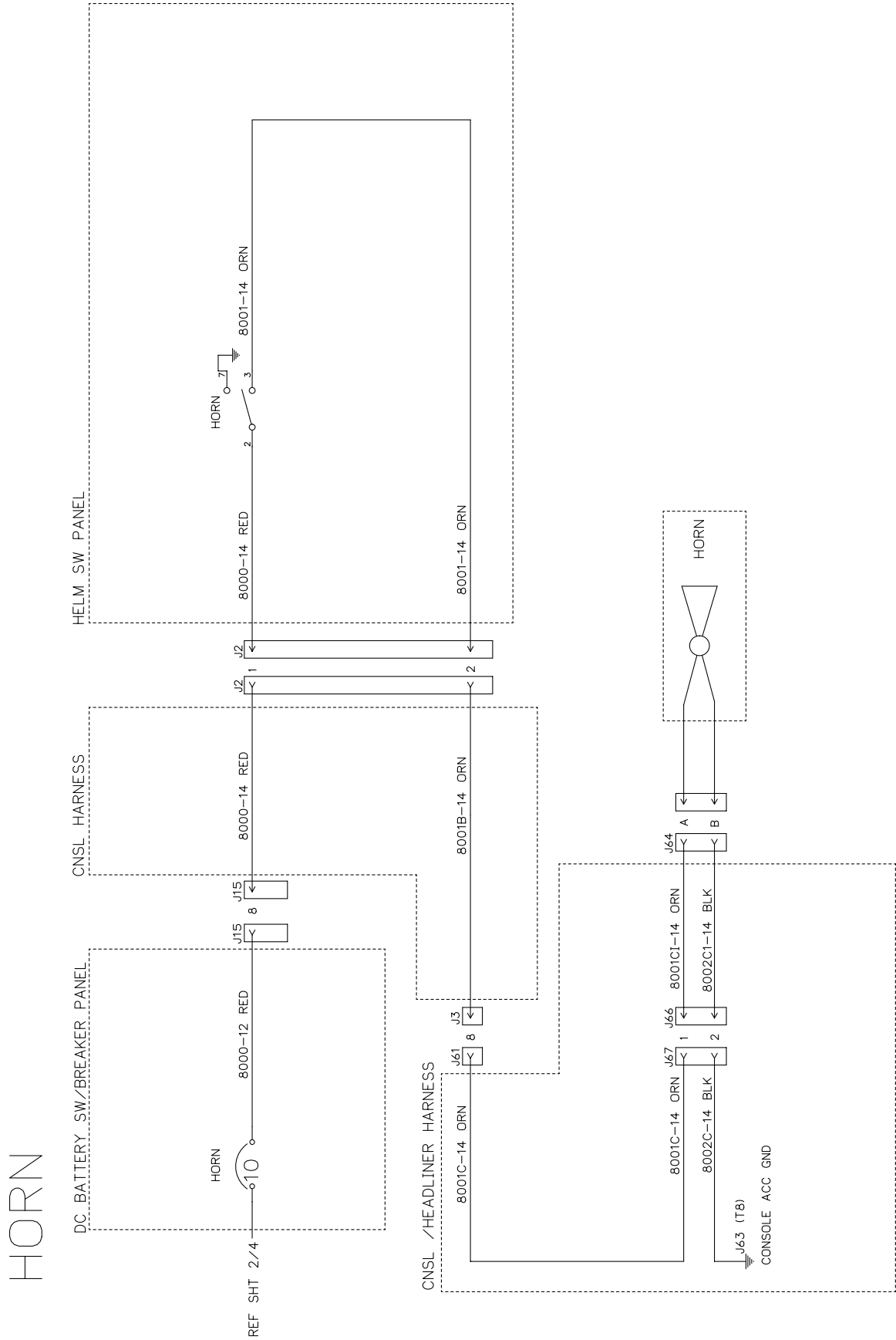

Section 4 • Electrical System

230 Outrage Schematic- Sheet 13
Fig. 4.20.1

H/T LIGHTING

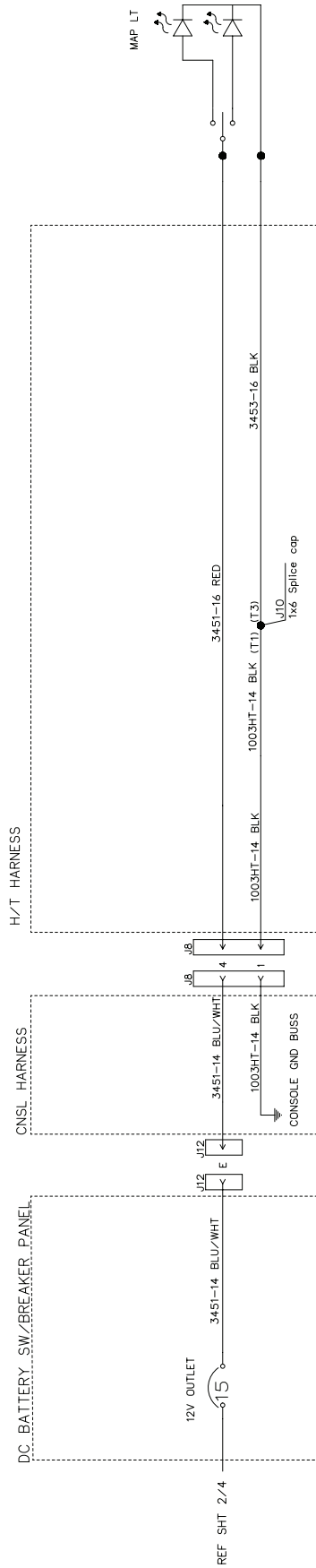

Section 4 • Electrical System

230 Outrage Schematic- Sheet 14
 Fig. 4.21.1

WASTE DISCHARGE

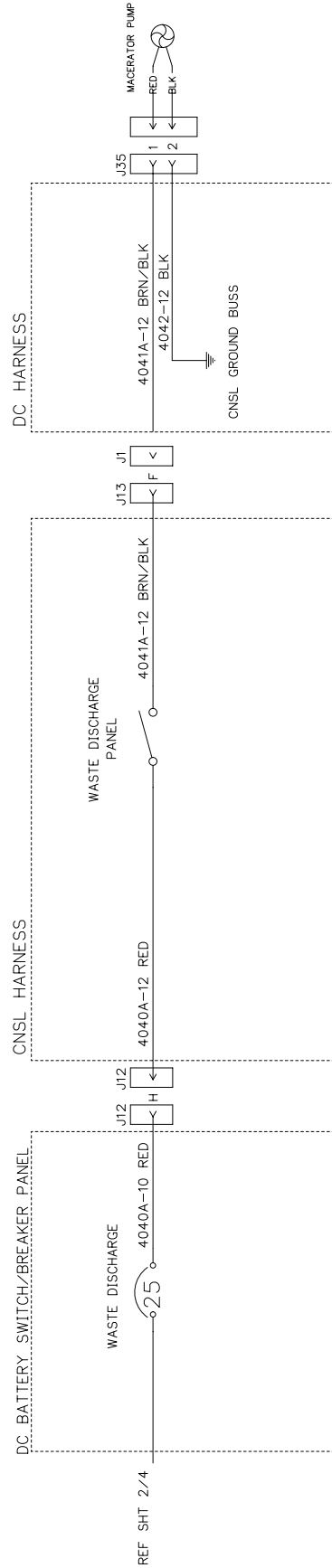

Section 4 • Electrical System

230 Outrage Schematic- Sheet 15
Fig. 4.22.1

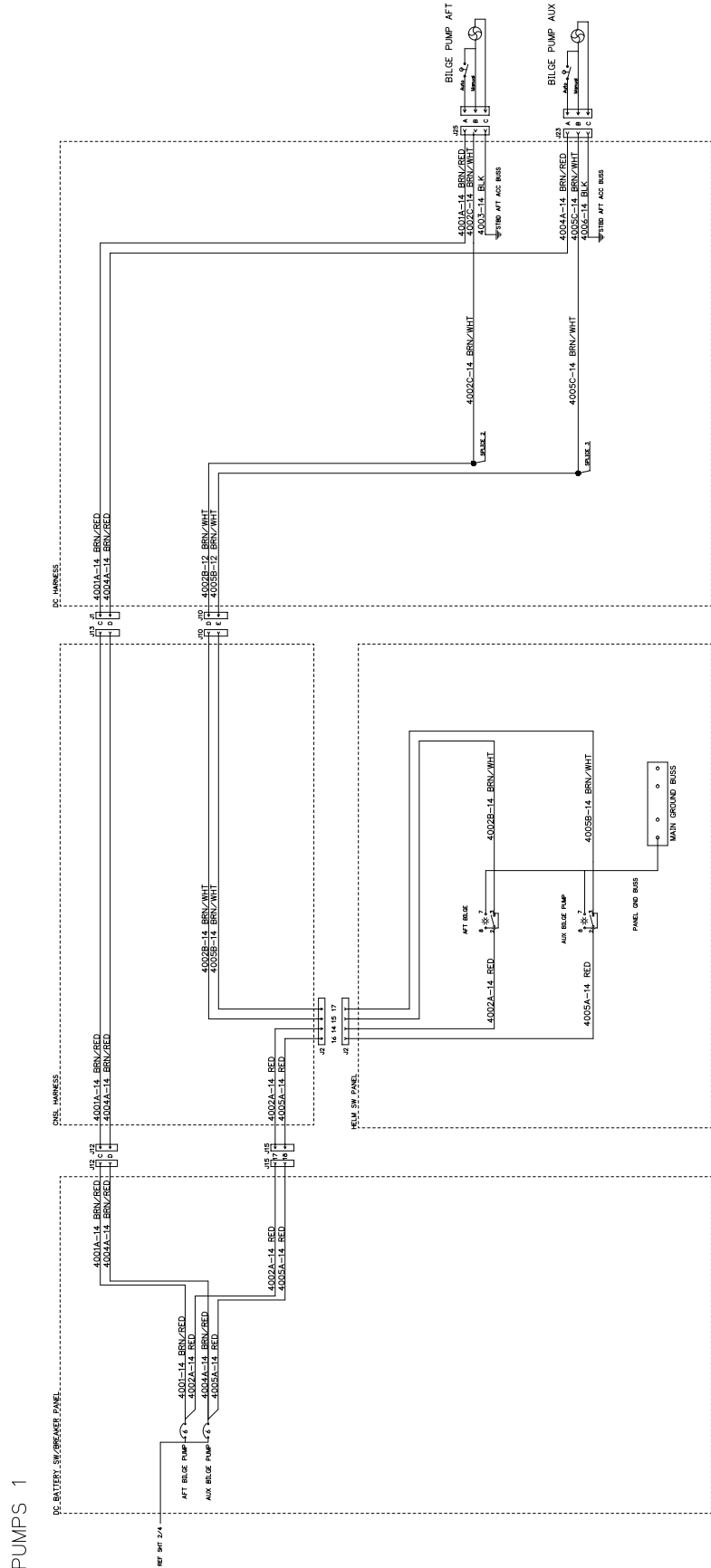

Section 4 • Electrical System

230 Outrage Schematic- Sheet 16
Fig. 4.23.1

PUMPS 2

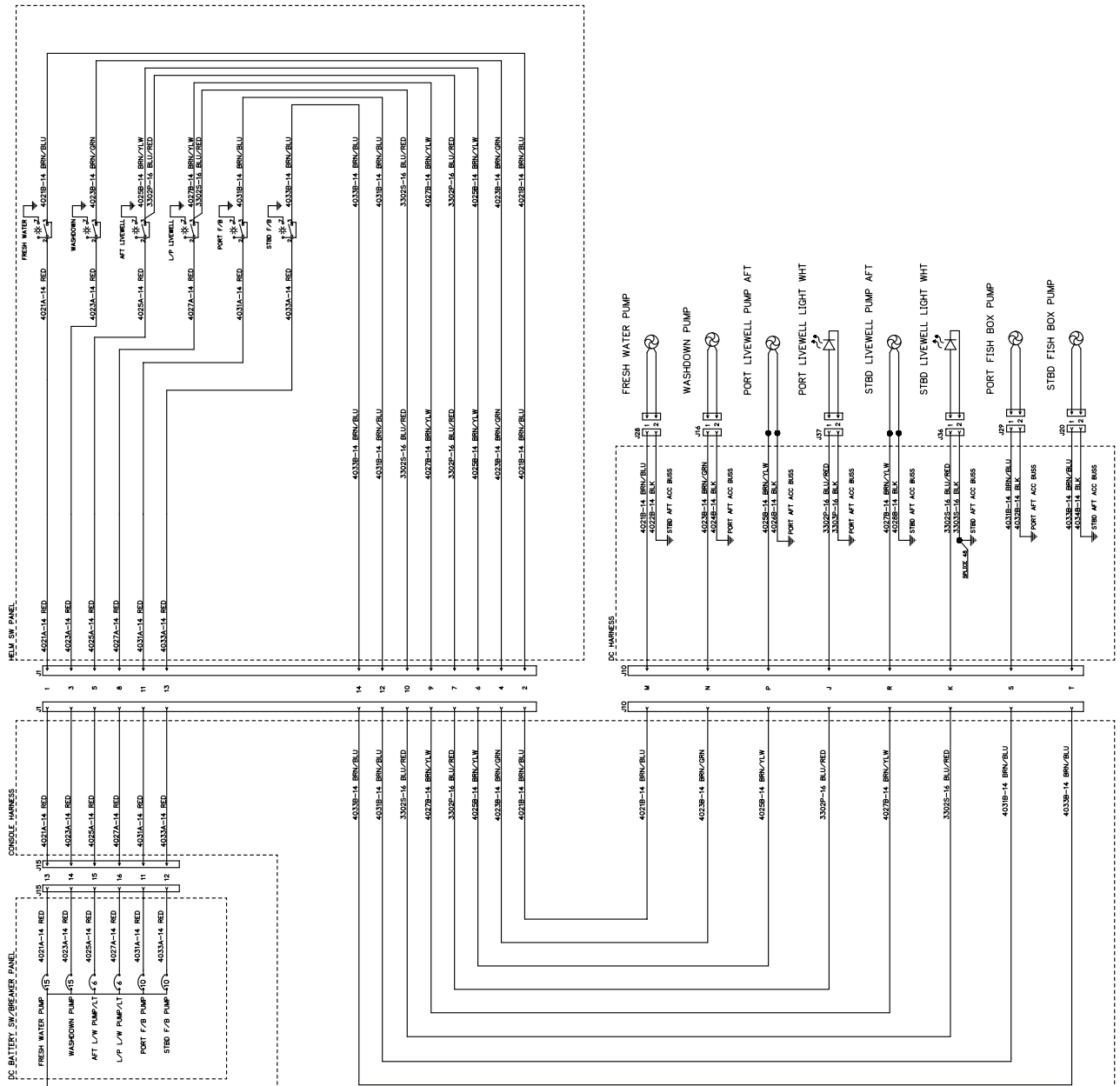

Section 4 • Electrical System

230 Outrage Schematic- Sheet 18
Fig. 4.25.1

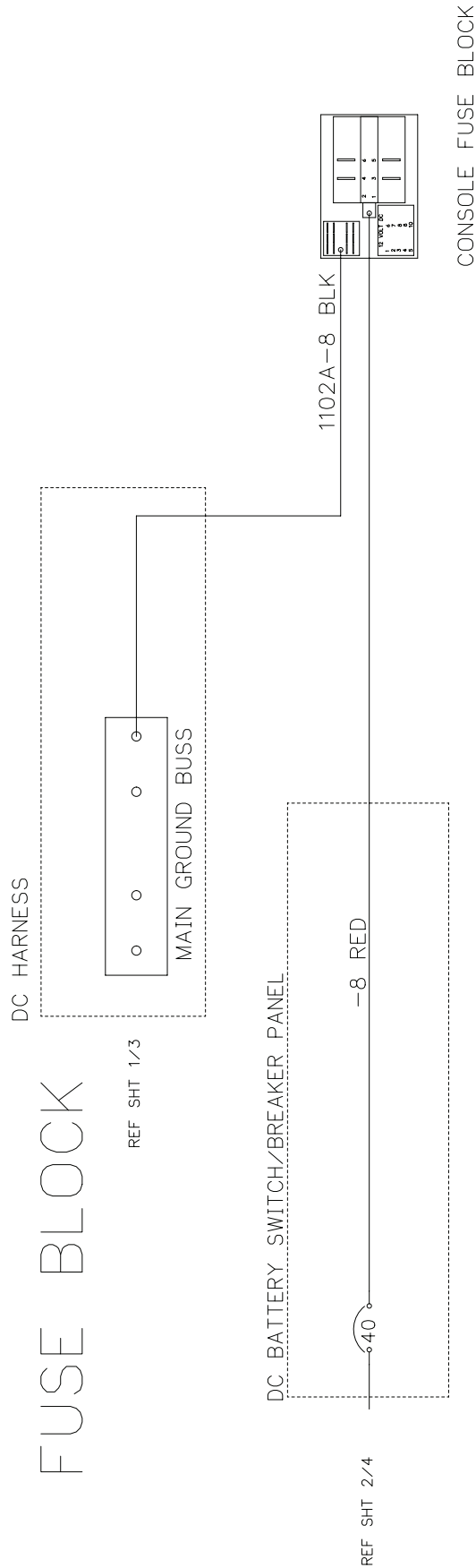

THIS PAGE INTENTIONALLY LEFT BLANK

Routine Care & Maintenance

NOTICE

Refer to the individual manufacturers' manuals for important information regarding service, care and maintenance of your boat, equipment and components. Failure to do so may in some cases void the warranty.

Owner's Manuals for your boat and each of the various components and equipment can be found in your Owner's Manual Packet.

⚠ DANGER

When using solvents read all information from the solvent manufacturer regarding safety and handling of the material.

Wear proper protective equipment to ensure your personal safety.

Only use solvents in a well ventilated area and keep all solvents away from open flame and any other forms of ignition.

Routine inspection, service and maintenance of your boat, boat systems and components are vital to assure your safety, as well as prolonging the life of your boat. You should develop regular routines for inspecting and servicing your boat.

⚠ WARNING IMPORTANT

Regularly inspect & test hardware, fittings, windshields, hatches, seams, etc. for proper seal. Reseal and/or readjust/tighten fittings, latches, etc. as needed.

The interval between necessary service or maintenance is highly variable, depending on the environment in which your boat will be used. For example, corrosion of boat parts and components will occur far more rapidly in a salt water environment than on a boat which is used in fresh water.

This section provides **only general guidelines** for the care and cleaning of your boat. It is **your responsibility** to determine whether maintenance and care intervals need to be accelerated due to your boat usage and/or operating environment.

Hull

Fresh water, saltwater and water temperature can all affect the types of growth that you will find on your boat's hull.

Any growth will affect the boat's performance and overall look. If it has been a while between inspections you might notice algae or slime growth on the hull. This can be cleaned with a coarse towel or soft bristle brush. The growth should be cleaned immediately after the boat has been removed from the water. If the growth is allowed to dry it will be much harder to remove.

Compounding may be necessary to remove more stubborn stains and chalking from the surface of your boat. If compounding is necessary it must be done after a thorough washing and prior to waxing.

If the growth is more severe, you may need to enlist the services of a professional hull cleaning company.

Check with your Boston Whaler® dealer for recommendations on a compatible rubbing compound for your boat or a professional hull cleaning company in your area.

Waxing the Gel Coat Surfaces

Waxing is necessary to provide added protection to the gel coat. A periodic good cleaning and waxing will also ensure that your boat will be protected and look good longer.

NOTICE

Waxing of the exterior surfaces is recommended to be done at least twice a year to protect the gel coat of your boat.

Do not wax over dirt. Make sure the surface of your boat has received a thorough washing and rinsing and is clean before waxing. If a rubbing compound has been necessary, make sure that any minor scratches or surface pitting is cleaned of compound residue. Use a good quality carnauba wax or a high quality wax designed for marine gel coat. Apply several coats.

Hull Maintenance

If using a pressure washer to clean the hull and deck surfaces of your boat it is important that you use the wide fan nozzle only and move the spray head in a continuous motion. Do not concentrate the high pressure on a small area of the boat surface and **NEVER** use the fine pinpoint nozzle as the concentrated stream can cause damage to the surface of your boat.

It is also recommended that you refrain from pressure washing the console as high pressure may compromise the integrity of the electronics and gauges as well as other equipment installed on your boat. Also avoid pressure washing all caulk seams.

When staining from build-up does occur, use only cleaning agents that are recommended for marine gel coat for use on those stubborn stains.

NEVER use an abrasive cleaner to wash your boat's hull.

NEVER use an abrasive pad to attempt to remove stubborn stains.

NEVER use strong solvents to clean.

NEVER apply tape or any other type of adhesives directly to the painted surfaces on your boat.

Use care when covering your boat's painted surfaces as tarps and other such covers can trap dirt and cause chafing. It is best to use a frame of either aluminum or wood to keep the cover up and allow air to circulate.

Hull Blistering

Due to the quality of the materials used in the hulls of Boston Whalers, blistering is rarely ever seen. Blistering is caused by water soluble materials in the hull laminate. The fiberglass and resin structure of your boat is porous. However, intrusion of water into the gel coat will take some time. The effect of osmotic pressure allows water to impregnate below the gel coat and substrate thus forming a blister.

There have been extensive university studies funded

by the United States Coast Guard regarding the cause and effect of blistering in the gel coat of fiberglass boats. Fiberglass blisters can form anywhere from near-surface layers of the gel coat to very deep into the fiberglass structure. The damage can range from cosmetic to catastrophic, (although the latter is a very rare occurrence). The studies seemed to point toward long term immersion of the hull in warm water as a primary cause of hull blisters. Stress cracks on the hull below the waterline also contribute to the formation of hull blisters.

Prevention

There are a variety of ways to prevent the formation of hull blistering. Epoxy coatings can be applied to the hull, followed by hull painting. An alkyd-urethane-silicone marine paint can also be used to aid in the prevention of hull blisters.

Reducing the amount of time that your boat stays in the water also helps prevent hull blisters from forming. Use of a trailer or boat lift will reduce the likelihood of hull blisters forming. Be sure to use a bunk type lift or trailer for storage of the boat out of water.

Contact your Boston Whaler® dealer for more information on the prevention and treatment of hull blisters.

Bottom Painting

DANGER

There are risks and dangers inherent with the use of paints and solvents. Dispose properly of all rags, rollers and trays used for painting. Follow all the precautions and regulations listed by the manufacturer before and after painting your boats hull.

NOTICE

If blisters are present in the hull, they need to be properly cleaned and dried out before any barrier protection can be applied.

CAUTION

Some bottom paints contain metals that can cause corrosion of the outboard engine. Leave a minimum of 3/4" unpainted around all engine parts. Use only a paint specifically designed for aluminum engines as anti fouling protection.

If your boat will spend most of its time in the water, painting the bottom of your boat's hull is a good way to slow the formation of hull blisters and to keep bottom growth (fouling) under control.

If you will be trailering the boat to and from the water, you might want to forgo the painting.

Following is an abbreviated section on painting your hull bottom. Your Boston Whaler® dealer should have information on properly painting your boat's hull or recommendations on businesses that will paint your hull for you.

Zinc Anodes

Sacrificial anodes (zinc) are installed on the trim tabs, and engines of your boat to protect underwater hardware. Zinc, being less noble than copper based alloys and aluminum used in underwater fittings, will deteriorate first and protect the underwater fittings from deterioration.

Zinc anodes cannot perform their function unless they are exposed. Putting paint on an anode smothers it, rendering it useless.

CAUTION

DO NOT paint over zinc plates. This action will render them useless and lead to deterioration of the underwater metal parts of your boat.

Bottom Painting a Bare Hull

Since the boat has never been painted preparation is the key to successful hull painting. Take extra care and time in preparation before proceeding to paint.

Begin by scrubbing the surface thoroughly with a stiff brush using an all-purpose marine soap and water to remove loose dirt and contamination. Flush with fresh water to remove all soap residue.

WARNING

Proper ventilation and capture of the dust created by sanding is essential. The dust created by sanding is toxic and should not be breathed. A proper fitting respirator must be used.

DO NOT use a paper filter mask.

The gelcoat will have to be dewaxed of mold release wax before sanding can begin, otherwise the wax will be dragged into the scratches and will reduce the adhesion properties of the paint.

Remove any mold release wax that may be present using fiberglass surface prep solvent and a scrub pad. Scrub only a few square feet at a time. Flush with fresh water. If the water beads up or separates, continue scrubbing the surface. When the water sheets off, the wax contaminate has been removed.

After the dewaxing is complete, application of a primer coat is recommended. Pay close attention to scratches, nicks and dings in the surface. If necessary, fill any repair areas with a watertite epoxy filler. After filler is cured, sand with 80 grit paper until smooth. Remove the sanding residue using a fiberglass solvent wash.

The paint can be applied after sanding and cleaning is complete. Follow the paint manufacturer's recommendations for application.

Bottom Painting a Pre-Painted Hull

WARNING

Bottom paint is designed to resist algae growth which means it has chemicals embedded in the paint that are harmful if ingested. Take all necessary precautions required before painting or repainting your boat's hull.

If the hull bottom is already painted, you must be sure to test the paint's adhesion to the already painted surface. If the paints are incompatible, the new paint will not adhere to the hull bottom or the paint will "lift" the old paint. **NEVER** apply paint without first

NOTICE

Painting your boat's hull will adversely affect the boat's speed and performance and may require re-propping if the maximum engine RPMs drop below the engine model/mfg recommended operating range.

preparing the old painted surface following the paint manufacturer's recommendations.

Follow the paint manufacturer's recommendation for applying the paint. Humidity and weather will play a role in how and when the paint is applied. Several thin layers are better than one thick layer.

To determine the waterline, you will need to place the boat in water with a full load of fuel and gear. Mark the waterline and measure above the marked line 1 to 3 inches for placement of the tape line.

Make sure that there is enough paint left to cover areas that were not accessible, (slings, jack stands etc.) and paint accordingly. Follow the paint manufacturer's recommendation for do's and don't's after the painting is complete.

NOTICE

Masking tape is NOT recommended for the types of paint you will be using.

Rubrail Care

The rubrail on your boat is constructed of an injected high density PVC vinyl material which laboratory tests have proven to be highly resistant to staining, fading and cracking.

As resilient as this material is, you still need to follow some basic maintenance precautions.

General maintenance requires a thorough cleaning with mild soap & water. **DO NOT** use any cleaning agents which contain chemicals.

Although the outer shell is tough and durable, there is a chance that it can be breached. Use care when docking or exposing the rubrail to conditions which may cause damage such as docking against heavily barnacle-encrusted pilings.

Some tears (cleanly sliced) can be repaired with a "Super Glue" type product.

Thoroughly clean and dry the affected area. Apply glue and hold the surfaces together.

Areas which have been torn or are affected by heavy abrasion will have to have the damaged section replaced. Please see your Boston Whaler® dealer for this type of repair.

Cleaning Fiberglass & Non-Skid

To protect your deck and non-skid areas from the deteriorating affects of the sun, oxidation, water spots and pollution, use a good quality "fiberglass and non-skid deck" wax every two to three months.

When applied to your deck and non-skid areas, as recommended by the manufacturer, the wax forms a protective non-slick surface which will keep debris from sticking. Dirt, soot, bird droppings, and even fish blood will rinse right off.

NOTICE

NEVER use abrasive cleaners, detergents or soft scrub type cleaners to wash your boats surfaces.

NEVER use abrasive pads, brushes or sponges to attempt to remove stubborn stains.

NEVER use strong solvents or detergents which contain chlorine.

Stainless Steel Care

The cleaner your stainless trim and fittings can be kept, the greater the assurance of optimum corrosion resistance. Without proper care even the best stainless steel will corrode.

Stainless steel is strong and corrosion resistant, but still requires maintenance to keep its appearance. Frequent routine cleaning of your stainless steel with a mild soap and water solution and coating with a good grade cleaning wax will help maintain the finish.

- Wash with mild soap and cold or lukewarm water.

- Dry THOROUGHLY.
- Apply cleaning wax with a soft, dry cloth.
- Allow wax to dry, then polish and buff.

Even the finest cleaning powders can scratch or burnish a mill-rolled surface. On polished finishes, rubbing or wiping should be done in the direction of the polish lines, NOT across them.

Crevice corrosion, a brownish coloring which occurs where two pieces of stainless hardware meet is caused by impurities in water and air. It can be easily cleaned with a good grade marine polish using a sponge, cloth or small bristled brush (for nooks and crannies).

NOTICE

NEVER use abrasive cleaners, detergents or soft scrub type cleaners to wash your boats surfaces.

NEVER use abrasive pads, brushes or sponges to attempt to remove stubborn stains.

NEVER use strong solvents or detergents which contain chlorine.

NEVER use silver cleaners.

Teak Maintenance

The teak features on your boat are constructed of natural wood, are durable in all climates, and require little maintenance. Clean teak surfaces by regularly washing with soap and water using a soft brush or sponge. Do not use a steel brush or steel wool. Do not use a pressure washer. Do not use strong solvents or harsh cleaners on the caulking as they can damage or dissolve the caulk. Bleach can be used to treat darker spots on the wood surface. Use fine grain sandpaper to keep the surface smooth and blemish free. There are several maintenance options for teak:

Let-it-be (Recommended)

Left alone with the elements, teak changes to a silver-grey patina. To maintain, occasionally wash with soap and water. A light sanding every few years keeps the surface smooth; always sand with the wood grain.

Oiling

Apply oil to retain or increase the darkness of the original wood. There are numerous products on the market that provide a variety of different characteristics. Refer to the manufacturer's instructions for proper application.

Lacquer

A correctly applied lacquer ensures years of low-level maintenance and minimizes the risk of mold. Some lacquers can be applied with various grades of thinner to reduce shine. The wood will likely darken when lacquer is applied. Carefully research product information to ensure it's suitable for both teak and caulking.

Seats (Mechanical Parts)

Always wash metallic parts with soap and water and rinse thoroughly with fresh water. Once dry, apply a light coating of lubricant to protect moving parts.

Check for loose or damaged hardware and tighten or replace as necessary.

Aluminum Care

Preventative maintenance is essential to life of the metals on your boat. The presence of salt particles and moisture is the major cause of white spots, pitting and corrosion.

The use of harsh chemicals can also cause deterioration. Manufacturers and applicators of protective coatings will not warrant protective coatings on metals in the marine environment. Proper owner maintenance is required to reduce deterioration which will result in most cases by failure to wash down and wipe dry after each use and/or the use of abrasive, acidic or other improper cleaners.

Wash completely using a soft cloth and mild detergent to remove salt particles. Hosing alone will not dislodge all particles. **DO NOT** allow soap to dry as it may cause stains on coated surfaces. Make sure to wash and dry the full circumference of aluminum parts.

Apply an aluminum protectorant at least twice each year, more frequently as conditions warrant. Neglect

Section 5 • Care & Maintenance

will cause pitting of the surface which cannot be reversed.

Inspect and repair or replace all damaged nylon bushings, washers or other hardware designed to prevent contact with dissimilar metals.

Whenever electrical or electronic changes are made to the boat, a qualified marine technician should check aluminum parts for stray currents. Make sure all electronic equipment is properly grounded with adequate sized wire.

Cushions

Saltwater, salt residue, dirt, ultra-violet rays etc. will take their toll on vinyl products causing them to lose their luster and texture.

The cushions on your boat are made of a durable vinyl material called OMNOVA which is protected by a finish called PreFixx®. PreFixx® will keep your cushions looking new far longer than most other vinyl upholstery.

To Clean Your Cushions

CAUTION

Solvents are flammable. Exercise proper care. Wear rubber gloves during all cleaning activity.

Use caution when cleaning around buttons, stitching and wooden or decorative trim as these solvents could seriously damage such areas.

- **Remove ordinary dirt and smudges** with a mild soap and water solution. Dry with a soft, lint-free cloth or towel.
- **More difficult stains** can be cleaned using rubbing alcohol (isopropyl alcohol). Rinse cleaned area with fresh water and dry with a clean, soft, lint-free cloth or towel.

- **Seemingly permanent stains** like ballpoint ink can be cleaned with active solvents such as nail polish remover when applied with a soft cloth or damp sponge and rubbed. Rinse cleaned area with fresh water and dry with a clean, soft, lint-free cloth or towel.

The vinyl material and superior finish has been tested to resist heavy abrasion. Complete cleaning instructions are included in the owner's packet. Read all information provided by the cushion manufacturer regarding the proper cleaning and maintenance.

Your cushions are not waterproof. They are constructed of open-cell foam and will absorb and hold water. The foam is wrapped with a plastic barrier which helps to keep water from being absorbed into the foam but also will not allow water to dissipate once the foam is soaked. **Do not leave the cushions in standing water or exposed to heavy, prolonged rain.**

If, in the event your cushions become waterlogged, remove the foam from the cushion, press as much water as you can from the foam and allow to air dry. Make sure the plastic wrap is dry before wrapping the foam and inserting it back into the cushion.

Cleaning Your Instrument Gauges

When gauges are exposed to a saltwater environment, salt crystals may form on the bezel and plastic covers. Remove the salt crystals with a soft damp cloth. Clean with a mild household detergent or plastic cleaner.

Never use abrasives or rough, dirty cloths to clean plastic parts. A mild household detergent or plastic cleaner should be used. Wipe clean with a damp chamois.

FOR MORE INFORMATION, CONTACT MERCURY MARINE CUSTOMER SERVICE AT 1-920-929-5040

Canvas Care and Maintenance

NOTICE

DO NOT use detergents, bleach or solvents to clean your canvas.

To keep your canvas and metal parts in good working condition and in good appearance, you will need to keep them clean.

The fabric should be cleaned regularly before substances such as dirt, pollen, etc. are allowed to accumulate on and become embedded in the fabric. The canvas can be cleaned without being removed from the installation.

Chafing, fiber wear from dirt and grit and deterioration from ultraviolet light can cause your canvas to degrade over time.

Maintaining a good appearance

- After each use, especially if used in salt water areas, rinse the canvas completely with fresh cold water.

On a regular basis

- Brush off any loose dirt, pollen, etc.
- Hose down with fresh cold water and clean with a mild solution of a natural soap in lukewarm water (maximum 100°F / 38°C).
- Allow the canvas to soak. **DO NOT ALLOW THE SOAP TO DRY.**
- Rinse thoroughly with fresh water.
- Let the canvas dry completely. **DO NOT** store any of the canvas pieces while wet.

The effects of ultraviolet light can sometimes be reduced by chemical treatment of canvas items.

Consult your Boston Whaler® dealer or check your canvas manufacturer's manual **BEFORE** using any chemical treatments on your canvas.

Cleaning Stubborn Stains

Soak fabric for approximately twenty minutes in a mild solution consisting of no more than 1/2 cup (4 oz.) of bleach and 1/4 cup (2 oz.) of natural

soap per gallon of lukewarm water (not to exceed 100° F / 38° C).

Rinse thoroughly in cold water several times. Allow the fabric to air dry completely.

NOTICE

Failure to remove all of the soap solution can cause deterioration of seams and prevent fabric from proper retreating.

Retreat the fabric using an air curing product such as 303 High Tech Fabric Guard to ensure water and stain repellency.

All canvas should be stored flat or rolled in a clean, dry space.

Maintaining Zippers and Hardware

Lubricate zippers and fasteners periodically with a clear silicone spray. In the absence of silicone spray, a wax candle can be used to lubricate the zipper track.

Replace any missing fasteners or any fasteners showing signs of corrosion.

NOTICE

DO NOT use petroleum based products, such as petroleum jelly, on the zippers or fasteners.

Cleaning Acrylic Windscreen

- Rinse windscreen thoroughly with clear water to remove any dust, dirt particles, salt water or environmental agents before applying cleaning products.

Use your bare hand, with plenty of water, to feel and dislodge any stuck-on dirt or foreign particles.

This should be done frequently to avoid build up of salt water, dirt and other environmental contaminants.

Section 5 • Care & Maintenance

- Using a soft non-abrasive cloth, wash windows inside and out with a mild soap (Woolite, Joy, Palmolive, etc.) and water solution. Rinse completely with cool water.

DO NOT USE DETERGENTS.

- Blot dry with a soft cloth or chamois to prevent water spots.

The use of a polycarbonate protective cleaner/restorer is recommended to keep your acrylic scratch resistant, clean and minimize the deteriorating effects of sunlight.

Never use a dry cloth or duster or glass cleaning solutions on acrylic.

DO NOT use solvents such as acetone, silicone spray, benzene, carbon tetrachloride, fire extinguisher fluid, dry cleaning fluid, lacquer thinner, glass cleaning solution or harsh detergents on acrylic.

The above substances will attack the surface of the acrylic.

Long Term Storage & Winterization

Long periods of storage, winter lay-up and/or non-use, common to boats, create unique problems. When preparing to store a boat for extended periods of two months or more it is best to make sure that the boat and its systems are properly conditioned for such extended periods of non-usage.

The guidelines presented on the following pages give basic instructions on “winterizing” your boat and boat systems. If inexperienced with the process of winterization it is best to hire the services of a professional.

In addition, always consult the owner’s manuals of the various systems and equipment on your boat for the manufacturer’s recommendations on winterizing and long term storage.

Engine



Never start or run your outboard (even momentarily) without having water circulating through the cooling water intake holes in the gear case. This will prevent damage to the water pump (running dry) or overheating of the engine.

Protecting your engine’s vital moving parts from corrosion and rust caused by freezing of trapped water or excessive condensation due to climatic changes is very important. Freezing water in the engine can cause extensive damage to the internal moving parts. Internal engine parts can also be affected by rust due to lack of proper lubrication

- Replace the engine oil and filter, running the engine to drain out as much old oil as possible.
- Flush the engine with fresh water using flush mufflers or a similar device attached to the raw water pickup.
- Let all water drain from the engine.
- Fog the engine while it is running. Spray until it stalls.
- Run fuel which has been treated with conditioner and stabilizer through the engine.
- Replace lower unit gear oil. Check for moisture in old oil, a sign of deteriorating seals.
- Remove the prop and grease the shaft and threads.
- Treat all grease fittings with the recommended lubricant.
- Lightly lubricate the exterior of the engine or polish with a good wax.
- Check engine mount bolts. Ensure that they are torqued to 55 ft/lbs.

In addition, be sure to follow all recommendations in your engine manufacturers operation manual.

Fuel System

Tank(s), hoses, and fuel pumps should be treated to help prevent the formation of varnish and gum.

Temperature extremes will cause condensation to accumulate in an empty or partially filled fuel tank leading to fuel contamination and/or premature wear of your system.

Fill the tank completely (100%) full and add fuel stabilizer and conditioner, following the manufacturer's recommendations, to provide fuel stability and corrosion protection.

NOTICE

Pay particular attention to the information provided in "Ethanol-Blended Fuel" in section 3 of this manual.

Electrical System

- Check all connections and tighten if necessary.
- Spray all connections with an anti-corrosion spray.

Battery

NOTICE

Remove battery from boat and store in a cool, dry location. Periodically check the battery during storage.

- Disconnect the battery cables (negative cable first).
- Remove the battery from the boat.
- Clean the terminal ends of the cables and battery terminals with a solution of baking soda and water. Rinse thoroughly with clean water.
- Apply a coat of grease on the terminal ends of the cables and the battery terminals.
- Store the battery in a cool, dry area.
- Use a trickle charger to keep the battery charged or charge the battery every 30-60 days.

NOTICE

Follow the manufacturer's recommendations for long term storage of your battery(s).

Deck

Clean the deck with soap, hot water and a stiff brush to clean up any oil spills.

Drainage

It is important to raise the bow of the boat enough to allow for proper drainage of water from the deck and bilge area. Make sure all the drainage fittings are clear and free of debris and plugs are removed. Store the engine in an upright position to promote adequate drainage of water.

Avoid Loss

Remove any valuables or anything that can be easily removed from the boat such as electronics, lines, PFDs, fenders, cushions, etc. and store at home.

Cover

When covering your boat it is best to use a frame of either aluminum or wood to keep the cover up. This allows air to circulate and discourages water from pooling on the cover.

NOTICE

DO NOT USE a bimini top in lieu of a cover. Damage and aging will occur while providing no protection for your boat.

Vents along the entire length of the cover will allow condensation to escape. Placing a series of foam pads between the hull and cover will also aid in air circulation and reduce condensation.

To help keep your boat dry and mildew free, consider placing commercial odor and moisture absorbing products in the boat under the cover.

Section 5 • Care & Maintenance

Trailer Storage

Repeatedly immersing the trailer in water during boat launching can cause a variety of problems. Water seeping into the wheel hubs will cause the grease to emulsify and can prematurely corrode the bearings.

Check with the trailer manufacturer for scheduled maintenance of your trailer.

Environment

Antifreeze and other winterizing fluids can be toxic to aquatic life and cause harmful effects to plant life.

Improper disposal of, or spillage of antifreeze and/or any winterization fluids can cause environmental problems when allowed to empty into waterways or on the ground. Furthermore, it is illegal, punishable at minimum by fines.

Used antifreeze or any winterization fluids, should not be disposed of into sanitary sewers or publicly owned treatment plants.

Persons who have any questions regarding recycling antifreeze or other toxic fluids should write or call their state's EPA office.

Reinforcement Locations

Your boat has been manufactured with reinforcement in various locations throughout the deck.

In the event you wish to add equipment to your boat which requires you to penetrate the deck with fasteners, the diagram on the next page illustrates the size, location and type of the reinforcement available. The chart below provides a description of the material and recommended fasteners to secure your equipment.

CAUTION

DO NOT attempt to secure equipment in any location other than those that are illustrated.

Reinforcement	Construction	Equipment weight	Fastener Type*
Plywood	Standard boatbuilding material	Light	Self-tapping screws
Trevira	Thick spunbound polyester fabric	Light	Sheet Metal screws
Sparalloy	High density plastic	Medium	Self-tapping screws
Phenolic**	Fiberglass reinforced composite board	Heavy	Drill & Tap

* In all cases it is recommended to drill and countersink a pilot hole to prevent damage to the gelcoat surface.
**Also known as Whaleboard

Reinforcement Location Diagram

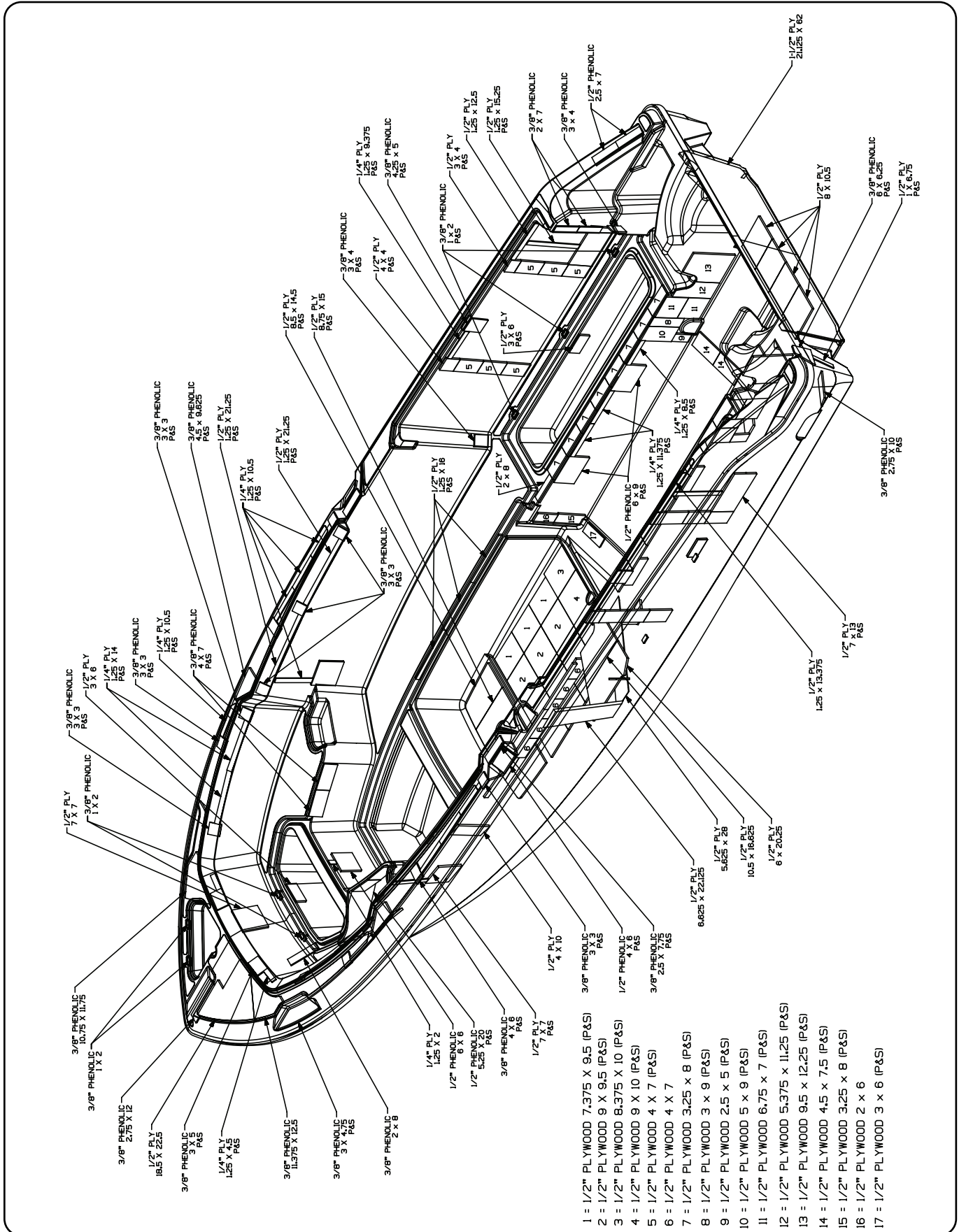

Section 5 • Care & Maintenance

Fill out the log below after scheduled service or maintenance is performed.

MAINTENANCE LOG			
DATE	ENGINE HOURS	SERVICED BY	MAINTENANCE PERFORMED
NOTES			