

325 Conquest
325 Pilothouse

Owner's Manual



THE UNSINKABLE LEGEND

325 Conquest

325 Pilothouse



The mission of Boston Whaler® is to provide consumers with the safest, highest quality, most durable boats in the world.



WARNING

Operating, servicing and maintaining a recreational marine vessel can expose you to chemicals including engine exhaust, carbon monoxide, phthalates, and lead, which are known to the State of California to cause cancer and birth defects or other reproductive harm. To minimize exposure, avoid breathing exhaust, service your vessel in a well-ventilated area and wear gloves or wash your hands frequently when servicing this vessel. For more information go to www.P65warnings.ca.gov/marine.

Introduction



T H E U N S I N K A B L E L E G E N D™

Welcome to the Boston Whaler® family and congratulations on your purchase!

For over six decades, Boston Whaler has engineered the most reliable and forward-thinking boats on the water. Every chapter of our history starts with a belief in pushing the limits of what's possible, and this heritage is cause for both reflection and celebration.

Standing behind every Whaler® is an extremely qualified network of dealers to provide you with a truly exceptional boating experience. Information and assistance is also available at bostonwhaler.com, where you will find customer resources including how-to videos, maintenance tips, and other technical content. While there, don't forget to sign up to receive future issues of Boston Whaler's lifestyle magazine, Whaler.

Since Boston Whaler's inception in 1958, we are committed to providing customers with the safest, highest-quality, most durable boats in the world. We are confident that as a Whaler owner you will love the quality and pride that is built into every boat.

From all of us here at Whaler, thank you for selecting one of our a legendary and innovative boats. May that choice bring you a lifetime of boating enjoyment.

Introduction

HISTORY

Since our founding more than six decades ago, Boston Whaler® has conceived and built peerless designs that meet boaters' diverse and changing needs. It all began in Braintree, Massachusetts with founder Richard Fisher's inspired new construction method featuring two significant innovations: first, a twin-sponson hull design that resulted in superior stability and a remarkably dry ride, and second, a unique foam-core construction that made the boat not only durable, but unsinkable as well. So for people whose livelihood and lives depend on their boat, Boston Whaler is the right choice because of our seaworthiness, dependability, and the inherent safety of a hull that won't sink even if severely damaged. Plain and simple, Boston Whaler boats are built to last.

In 1961, Fisher's demonstration of that unsinkability was captured by *Life* magazine in photos showing a Whaler® boat being sawed in half and Fisher then motoring away in the remaining half. True to Fisher's vision, Boston Whaler's world-class team has consistently pushed the envelope, furthering advances in manufacturing, design, navigation, and propulsion technologies.

On September 26, 1996, Richard Fisher was posthumously inducted into the National Marine Manufacturer's Association (NMMA) hall of fame for accomplishments made in marine engineering and construction.

In 1958, the legend is born as company founder Dick Fisher demonstrates a Boston Whaler's total unsinkability.



Introduction

Table of Contents

Introduction

Welcome Letter	Intro-1
History	Intro-2
Preface.....	Intro-5
Limited Warranty (US/Canada).....	Intro-6
Limited Warranty (Non-US/Canada)	Intro-11
CARB Warranty Statement	Intro-15
Privacy Statement	Intro-16
Owner's Manual	Intro-17
Contact Us.....	Intro-17
Boating Information	Intro-17

Chapter 1 • Safety

Safety Labels	1-1
Safe Boating	1-2
Maintain Control.....	1-3
Boarding.....	1-3
Impaired Operation	1-3
Legally Mandated Equipment	1-5
Personal Flotation Devices (PFD's)	1-5
Fire Extinguisher.....	1-5
Sound-producing Devices	1-5
Visual Distress Signal	1-5
Carbon Monoxide (CO)	1-6
Carbon Monoxide Detector.....	1-6
Lifesaving Equipment.....	1-8
Emergency Situations	1-8
Water Rescue.....	1-9
Fire	1-9
Flooding, Swamping and Capsizing	1-10
Propulsion, Control or Steering Failure	1-11
Grounding	1-11
Distress Signals.....	1-11
Radio Communications	1-12
Weather	1-12
Swimming, Diving and Water Skiing.....	1-13
Engine Emergency Stop Switch	1-15
Float Plan	1-16
Chart your Course	1-16
Environmental Considerations	1-17
Homeland Security Restrictions	1-17
America's Waterway Watch	1-17
Safety Label Locations	1-17
Symbols Key	1-23

Chapter 2 • General Information

Construction Standards.....	2-1
Hull Construction.....	2-1
Hull Identification Number.....	2-1
Vessel Servicing	2-1
Manufacturer's Certification.....	2-1
Certification Plates.....	2-2
Certification Design Category	2-3
Power Capacity	2-3
Specifications and Dimensions.....	2-4
Deck Occupancy.....	2-5
Recommended Occupant Locations.....	2-6
Location of Thru-hull Fittings.....	2-7
Features	2-8
Deck.....	2-8
Cabin.....	2-9
Cockpit	2-10
Convertible Lounge.....	2-11
Cockpit/Transom.....	2-12
Hardtop	2-14
Notable Options	2-15
Storage	2-16
Smartcraft VesselView	2-18
Mobile	2-18
Digital Throttle/Shift	2-18
Power Trim Operation.....	2-19
Active trim (Option).....	2-19
Navigation Lighting.....	2-19
Trim Tabs.....	2-21
Joystick Piloting (Option)	2-21
Canvas (Option)	2-23
Sun Shade (Option).....	2-23
Bow Shade (Option)	2-23
Electric Windshield Vent.....	2-23
Entertainment System	2-24
Electric Stove (Option).....	2-24
Galley Refrigerator/Freezer	2-25
Cockpit Table (Option).....	2-25
V-Berth.....	2-26

Introduction

Radial Outriggers (Option)	2-26
Transom Door	2-28
Docking, Lifting and Trailering	2-28
Propeller	2-30
Underwater Lights (Option).....	2-30
Pilothouse with Heater (Option)	2-31

Chapter 3 • Systems Overview & Operation

Bilge Pumps.....	3-1
Power Steering.....	3-2
Fuel System	3-3
Starting the Engines	3-7
Stopping the Engines.....	3-8
Fresh Water System	3-8
Water Heater (Option).....	3-10
Livewell	3-12
Raw Water Washdown.....	3-14
Fish Box with Pumpout Discharge.....	3-14
Head System	3-15
Air Conditioning (Option)	3-17
Generator	3-19
Fire Suppression System (Option).....	3-21
Galley.....	3-22
Foldaway Seat.....	3-22
Dive Door	3-25
Dive ladder	3-25
Companion Lounge Seat	3-26
Reboarding Ladder	3-26
Entertainment System	3-26
Gyroscopic Stabilizer.....	3-27
Cockpit Drawers and Storage	3-28
Pull-out Grill (Option)	3-28
Anchoring	3-29
Anchor Windlass	3-31
Manual Windlass Operation	3-32
Spotlight (Option)	3-33
Bow Thruster (Option).....	3-34

Chapter 4 • Electrical

DC Electrical System	4-1
Batteries.....	4-1
Remote Battery Switches	4-1
Automatic Charging Relays.....	4-3
Bow Thruster Switch.....	4-3
Battery Maintenance.....	4-4
Battery Charger.....	4-6
AC Electrical System	4-6

Shore Power	4-6
Equipment Leakage Circuit Interrupter.....	4-7
Component Breakers	4-8
Fuse Block	4-9
Ground Fault Interrupter.....	4-9
12 Volt Accessory Receptacles.....	4-9
Electric Downrigger Receptacles.....	4-10
Distribution Panels.....	4-11
Rigging.....	4-13
NAUTIC-ON Remote Connectivity	4-14
Transducer.....	4-14
C-Zone Digital Switching	4-14
C-Zone Wireless Remote	4-16
C-Zone/Raymarine Interface.....	4-16
VesselView Interface	4-20
Wiring Identification Chart	4-21
Electrical Schematics	4-21

Chapter 5 • Maintenance

Routine Care and Maintenance.....	5-1
Waxing the Gel Coat Surfaces	5-1
Hull Maintenance.....	5-2
Hull Blistering	5-2
Bottom Painting	5-3
Rubrail Care.....	5-4
Cleaning Fiberglass and Non-Skid	5-4
Stainless Steel Care.....	5-4
Teak Maintenance	5-5
Seats (Mechanical Parts).....	5-5
Aluminum Care	5-5
Cushions.....	5-6
Canvas Care and Maintenance.....	5-6
Vinyl Windows	5-7
Cleaning Tempered Glass Windshield	5-7
Long-term Storage and Winterization.....	5-7
Engine.....	5-8
Fuel System.....	5-8
Trailer Storage	5-10
Environment	5-10
Reinforcement Locations.....	5-11

Attachments

Commissioning Checklist

Introduction

Preface

READ AND RETAIN this manual. If the boat is sold, ensure all documentation is transferred to the new owner.

Information in this publication is based on the latest product specifications available at the time of printing. Boston Whaler reserves the right to make changes at any time without prior notice. Boston Whaler is not responsible for specification changes to parts or accessories manufactured by other companies.

Brunswick Corporation registered trademarks: Mercury Marine, Mercury Racing, Optimax, Nautic-On, Skyhook, SmartCraft, Verado, Vantage, VesselView, VesselView Mobile.

Boston Whaler, Inc. registered trademarks: Boston Whaler, Boston Whaler with harpoon and hull logo, Conquest, Dauntless, Montauk, Outrage, Realm, Unibond, Whaler.

All other trademarks listed in this publication are the property of their respective owners.

BOSTON WHALER® • A BRUNSWICK COMPANY

© January 2020 Brunswick Corporation



BOSTON WHALER LIMITED MANUFACTURER WARRANTY (US AND CANADA)

Boston Whaler, Inc. (“Boston Whaler”) provides the following Limited Manufacturer Warranty to the original retail owner of its 2022 model year boats, if purchased from an authorized Boston Whaler Dealer and operated under normal, non-commercial use (“Boat”), subject to the remedies, exclusions, and limitations set out below.

1. **Ten-Year Structural Hull Limited Warranty:** Any Structural Hull Defect in material or workmanship which is reported within ten (10) years from the date of sale to the original retail owner will be repaired or replaced at Boston Whaler’s sole discretion. The “Hull” shall mean the single fiberglass molded shell and integral structural components. A Structural Hull Defect shall mean a substantial defect in the Boat’s Hull which causes the boat to be unfit or unsafe for general use as a pleasure craft under normal operating conditions.

2. **Three-Year Limited Warranty on Components Manufactured or Installed By Boston Whaler:** (not applicable to 13 Super Sport or 16 Super Sport models): Boston Whaler will repair or replace, at its sole discretion, any components manufactured or installed by Boston Whaler that are defective in factory materials and/or workmanship, which are reported within three (3) years from the date of sale to the original retail owner, and are not addressed in the specific warranties listed in paragraphs 1 or 4 or set out in the Exclusions paragraph below.

3. **One-Year Limited Warranty on Accessory Components for the 13 Super Sport and 16 Super Sport Models:** Boston Whaler provides the following Limited Warranty to the original retail owner of any factory-authorized accessory for the 2022 model year 13 Super Sport and 16 Super Sport, if purchased from an authorized Boston Whaler Dealer, authorized Boston Whaler website or any Boston Whaler affiliate and utilized under normal, non-commercial use (“Accessory”), subject to the remedies, exclusions, and limitations set out below. Boston Whaler will repair or replace, at its sole discretion, any Accessory that is defective in material or workmanship, which is reported within one (1) year from the date of sale to the original retail owner. Boston Whaler is not responsible for any defect and/or damage to the Accessory and/or the boat caused by improper installation, whether performed by the retail owner, dealer or any other third party.

4. **One-Year Limited Warranty on Upholstered Items, Canvas, Teak, and Powder Coating:** Boston Whaler will repair or replace, at its sole discretion, any upholstered items, canvas, teak, and powder coating manufactured or installed by Boston Whaler that are defective in factory materials and/or workmanship and are reported within one (1) year from the date of sale to the original retail owner.

5. **Limited Engine Warranty:** Retail owners will be entitled to the limited engine warranty as provided in the warranty manual from the engine manufacturer that was delivered to the retail owner with his or her Boston Whaler Boat.

EXCLUSIONS

This Limited Manufacturer Warranty does not apply to any boat which has been salvaged or declared a total loss or constructive total loss for any reason not covered in this limited warranty. This Warranty also does not apply to the following items:

- 1) Expenses for hauling out or transportation to and from the dealer or the Boston Whaler factory for warranty service.
- 2) Equipment or accessories which are not installed by Boston Whaler or which carry their own individual warranties, including but not limited to engines, engine components, batteries, propellers, controls, steering mechanisms, and electronics.

- 3) Damage, deterioration, discoloration or mold of cushions or cosmetic surface finishes, including scratches, gouges, chips, chalking, blistering, cracking, crazing, fading or oxidation of gel coat, stress lines, plated or painted metal and stainless steel finishes, plastics or acrylic materials, or anti-fouling bottom paint.
- 4) Windshield breakage and leakage.
- 5) Any Boston Whaler Boat initially sold at retail by a party other than an authorized Boston Whaler dealer.
- 6) Damage resulting from abuse, misuse, improper rigging and installation by an owner or any other person or entity that is not an authorized dealer, accidents, or overloading or powering in excess of the recommended maximum horsepower.
- 7) Failure of the owner to use, maintain, or store the boat as specified in the Boston Whaler owner's manual; and any other failure to provide reasonable care and maintenance. Normal wear and tear maintenance items are excluded from warranty coverage including but not limited to filters, bulbs, batteries, bungees, wiper blades, anchor rope, trailer finishes, tires, brakes, bearings, and lights.
- 8) Any Boston Whaler Boat which has been altered or modified from Boston Whaler factory specifications, including penetration of the hull by anyone other than Boston Whaler factory personnel or Boston Whaler authorized dealer service personnel following factory specified procedures.
- 9) Damages resulting from use of improper trailer, improperly placed supporting bunks or slings, incorrect bunks placement, or improper boat lift or sling.
- 10) Any Boston Whaler Boat used for commercial purposes, which includes, but is not limited to, any for-profit or other revenue-generating uses.
- 11) Any representation or implication relating to speed, range, fuel consumption or estimated performance characteristics.
- 12) Any failure or defect caused by an act of nature resulting in damage, cost, or expense.
- 13) Any failure or defect arising from a previous repair made by a non-authorized service provider.
- 14) Any item exceeding the expressed coverage limits specified in any Boston Whaler Limited Manufacturer Warranty.
- 15) Failure of the owner to use, maintain, or store an Accessory in reasonable fashion; and any other failure to provide reasonable care and maintenance.
- 16) Any accessory which has been altered or modified from Boston Whaler factory specifications.
- 17) Any accessory not purchased from an authorized Boston Whaler Dealer, authorized Boston Whaler website, or authorized Boston Whaler affiliate. For a list of Boston Whaler's affiliates, please refer to www.brunswick.com.
- 18) Any accessory used for commercial purposes, which includes but is not limited to, any for-profit or other revenue generating uses.
- 19) Any defect or repair requiring redesign of the Boat, except pursuant to the recall provisions of the United States Federal Boat Safety Act of 1971 or the recall laws of any other foreign jurisdiction.

SOLE REMEDY

THE REMEDY OF REPAIR OR REPLACEMENT OF PARTS OR MATERIALS THAT ARE FOUND TO BE DEFECTIVE IN FACTORY MATERIALS OR WORKMANSHIP COVERED BY THIS LIMITED MANUFACTURER WARRANTY SHALL CONSTITUTE THE OWNER'S SOLE AND EXCLUSIVE REMEDY AGAINST BOSTON WHALER FOR ANY CLAIMS WHATSOEVER OF ECONOMIC LOSS

RESULTING FROM PRODUCT FAILURE. In keeping with environmental policies and practices, Boston Whaler reserves the right to utilize reconditioned, refurbished, repaired or remanufactured products or parts in the warranty repair or replacement process. Such products and parts will be comparable in function and performance to an original product or part and warranted for the remainder of the original warranty period. In no event shall any repair or replacement under this Limited Manufacturer Warranty exceed the fair market value of the product as of the date of the owner's claim. Acceptance of any product returned or any refund provided by Boston Whaler shall not be deemed an admission that the product is defective. Products that are replaced become the property of Boston Whaler.

OTHER LIMITATIONS

EXCEPT AS SET FORTH HEREIN, THERE ARE NO OTHER WARRANTIES, EITHER EXPRESS OR IMPLIED, PROVIDED BY BOSTON WHALER ON THIS BOAT. ALL OTHER WARRANTIES, EXPRESS OR IMPLIED, INCLUDING IMPLIED WARRANTIES OF FITNESS AND MERCHANTABILITY, ARE EXPRESSLY EXCLUDED. BOSTON WHALER FURTHER DISCLAIMS ANY LIABILITY FOR ECONOMIC LOSS ARISING FROM CLAIMS OF PRODUCT FAILURE, NEGLIGENCE, DEFECTIVE DESIGN, MANUFACTURING DEFECT, FAILURE TO WARN AND/OR INSTRUCT, LACK OF SEAWORTHINESS, AND ANY OTHER THEORY OF LIABILITY NOT EXPRESSLY COVERED UNDER THE TERMS OF THIS LIMITED MANUFACTURER WARRANTY.

ANY IMPLIED WARRANTY OF MERCHANTABILITY OR FITNESS FOR A PARTICULAR PURPOSE IS DISCLAIMED. TO THE EXTENT THE IMPLIED WARRANTY CANNOT BE DISCLAIMED, IT IS LIMITED TO THE SHORTER OF ONE YEAR FROM THE DATE OF DELIVERY TO THE FIRST RETAIL OWNER OR THE DURATION OF THE RESPECTIVE EXPRESS LIMITED WARRANTIES STATED HEREIN. TO THE EXTENT ALLOWED BY LAW, NEITHER BOSTON WHALER, NOR THE SELLING DEALER, SHALL HAVE ANY RESPONSIBILITY FOR LOSS OF THE BOAT, LOSS OF TIME, INCONVENIENCE, COMMERCIAL LOSS OR CONSEQUENTIAL DAMAGES. SOME STATES DO NOT ALLOW LIMITATIONS ON HOW LONG AN IMPLIED WARRANTY LASTS, SO THE ABOVE LIMITATION MAY NOT BE APPLICABLE. SOME STATES DO NOT ALLOW THE EXCLUSION OR LIMITATION OF INCIDENTAL OR CONSEQUENTIAL DAMAGES, SO THE ABOVE LIMITATIONS OR EXCLUSIONS MAY NOT BE APPLICABLE. THIS WARRANTY GIVES THE OWNER SPECIFIC LEGAL RIGHTS, AND THE OWNER MAY ALSO HAVE OTHER RIGHTS WHICH VARY FROM STATE TO STATE OR COUNTRY TO COUNTRY.

STATUTE OF LIMITATIONS

Any action for rescission or revocation against Boston Whaler shall be barred unless it is commenced within one (1) year from the date of accrual of such cause of action. This provision does not grant any consumer a right of rescission or revocation against Boston Whaler, where such right does not otherwise exist under applicable law. Some states may not allow the applicable statute of limitations for rescission or revocation to be reduced, so this provision may not apply to each retail owner.

OWNER'S OBLIGATIONS

To initiate a warranty claim, it is the responsibility of the owner to contact an authorized Boston Whaler dealer immediately after discovery of any defect, describe the nature of the problem, and provide a hull serial number, date of purchase, and name of selling dealer. The authorized dealer will notify Boston Whaler, who is solely responsible for determining and authorizing in writing the remedial action(s) to be performed at either an authorized Boston Whaler dealership chosen by Boston Whaler or at the Boston Whaler factory. The owner should notify Boston Whaler of any boat being repaired by an authorized Boston Whaler dealer which has been at the dealership for fifteen (15) days, or of any claimed defect which was not corrected after

one repair attempt. The owner must provide Boston Whaler with a reasonable opportunity to repair, and reasonable access to the Boston Whaler Boat for warranty service and the owner shall pay for all related transportation charges and/or travel time. If the owner cannot deliver the product to such a dealer, written notice must be given to Boston Whaler. Boston Whaler will then arrange for the inspection and any covered repair and the owner shall pay for all related transportation charges and/or travel time. Our privacy policies are available at www.bostonwhaler.com.

ASSIGNMENT OF COMPONENT WARRANTIES

Except as expressly set out herein, all warranties provided by the manufacturers and distributors of components, equipment, and parts on the boat (collectively "Component Manufacturers") are hereby assigned to the owner to the extent permitted by the Component Manufacturers, as the owner's sole and exclusive remedy with respect to such items.

REGISTRATION & WARRANTY TRANSFER POLICY

The limited warranty coverage is activated by the authorized selling dealer registering the sale of a new Boat with Boston Whaler.

The Ten-Year, Three-Year, and One-Year limited warranties are transferable to a subsequent owner, except the one-year Accessory warranty which is not transferrable and this Limited Manufacturer Warranty will not transfer to any new owner of a boat which has been salvaged and resold, or resold after a declaration of a total loss or a constructive total loss, i.e., the cost of repair exceeds the value of the boat. The new owner must fill out and submit the online Boston Whaler warranty transfer form, accessible from www.bostonwhaler.com. A copy of the bill of sale will be required to submit with the form. The warranty transfer must be completed within 30 days of purchase.

MODIFICATIONS & SEVERABILITY

The terms and conditions contained herein, as well as those of any documents prepared in conjunction with the sale of this vessel may not be modified, altered or waived by any action, inaction, or representations, whether oral or in writing, except upon the expressed, written authority of a management level employee of Boston Whaler. The invalidity or unenforceability of any one or more of the provisions herein shall not affect the validity and enforceability of the other provisions.

GOVERNING LAW AND VENUE

This Warranty shall be interpreted and construed according to and governed by the laws of the State of Tennessee, without regard to conflict of law principles. Venue for any and all disputes arising out of or related to this Warranty, including without limitation the interpretation, performance or breach of this Warranty, shall be solely and exclusively before the United States District Court for the Eastern District of the State of Tennessee. The parties consent to the in personam jurisdiction of said court for the purposes of any such litigation and waive, fully and completely, any right to dismiss and/or transfer any action pursuant to 28 U.S.C. Section 1404 or 1406 (or any successor statutes) or the doctrine of forum non conveniens. If the United States District Court does not have subject matter jurisdiction of said matter, then such matter shall be litigated solely and exclusively before the appropriate state court of competent jurisdiction located in Knox County, Tennessee, and the parties consent to the personal jurisdiction of such court for the purpose of such litigation.

SAFETY

It is your responsibility (as well as the responsibility of any other operator of this boat) to be familiar with and observe all local, state and federal laws, rules and regulations regarding boating, navigation and boating

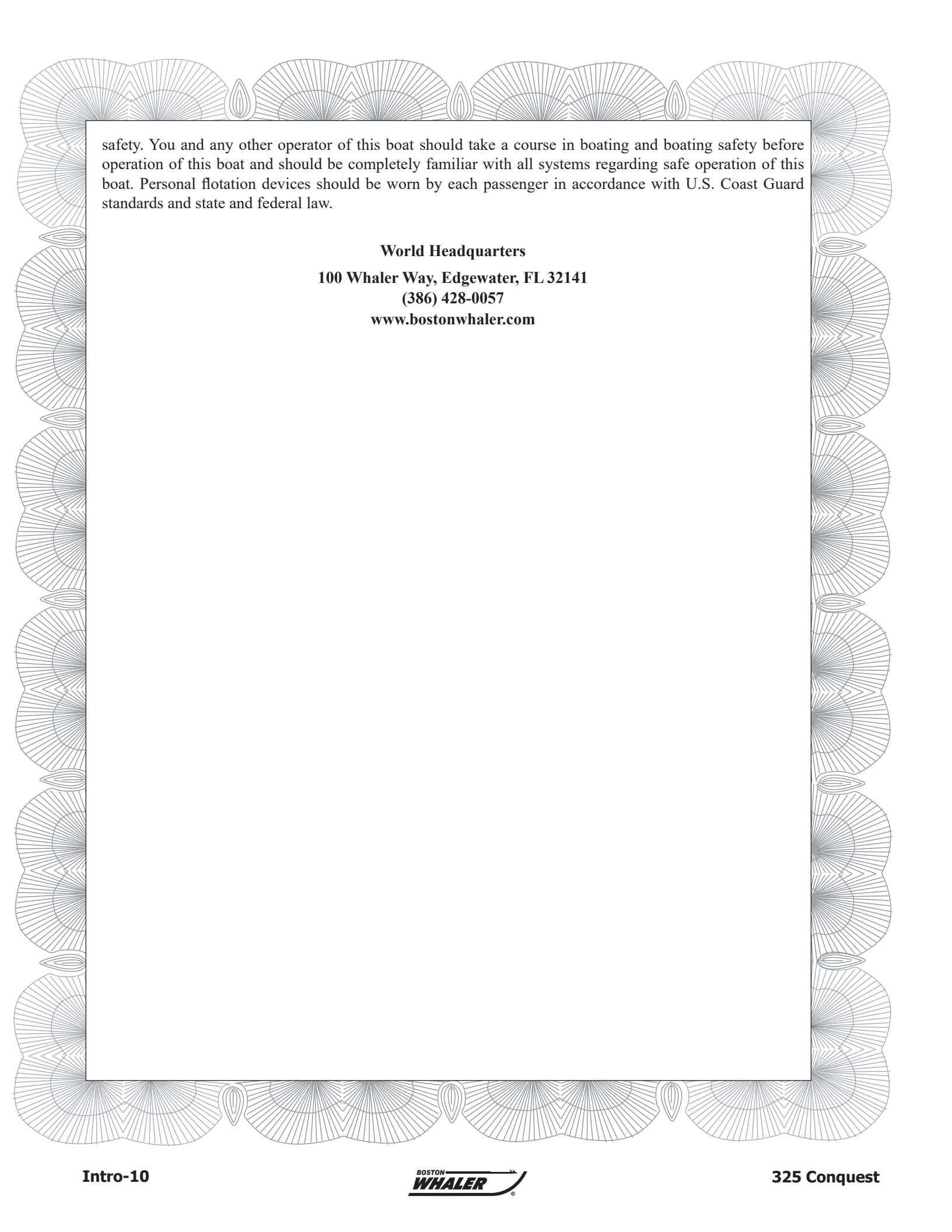

safety. You and any other operator of this boat should take a course in boating and boating safety before operation of this boat and should be completely familiar with all systems regarding safe operation of this boat. Personal flotation devices should be worn by each passenger in accordance with U.S. Coast Guard standards and state and federal law.

World Headquarters
100 Whaler Way, Edgewater, FL 32141
(386) 428-0057
www.bostonwhaler.com

BOSTON WHALER LIMITED MANUFACTURER WARRANTY (Outside the U.S. or Canada)

Boston Whaler, Inc. (“Boston Whaler”) provides the following Limited Manufacturer Warranty to the original retail owner of its 2022 model year boats, that if purchased from an authorized Boston Whaler dealer and operated under normal, non-commercial use, the authorized dealer will repair or replace, at its sole discretion, any defect in material or workmanship in the Boston Whaler Boat that is reported within the applicable Limited Manufacturer Warranty periods and within the scope as set out below.

Mandatory warranty rights, including a consumer’s mandatory statutory rights, by law are not affected by this Limited Manufacturer Warranty and in particular not limited or excluded. These mandatory legal rights exist regardless of whether a warranty claim occurs or rights are asserted under this Limited Manufacturer Warranty.

SCOPE

This Limited Manufacturer Warranty applies only to Boston Whaler Boats purchased outside of the US and Canada, including the territory of the European Union and Australia, and to recreational use customers only (not commercial users). Commercial use, which voids the Limited Manufacturer Warranty, is defined as any use of the product which generates income, even if the product is only occasionally used for such purposes. Routine maintenance outlined in the Operation and Maintenance Manual must be timely performed in order to maintain Limited Manufacturer Warranty coverage.

This Limited Manufacturer Warranty applies to the following items:

1. **Ten-Year Structural Hull Limited Warranty:** Any Structural Hull Defect in material or workmanship which is reported within ten (10) years from the date of sale to the original retail owner will be repaired or replaced at Boston Whaler’s sole discretion. The “Hull” shall mean the single fiberglass molded shell and integral structural components. A Structural Hull Defect shall mean a substantial defect in the Boat’s Hull which causes the boat to be unfit or unsafe for general use as a pleasure craft under normal operating conditions.
2. **Three-Year Limited Warranty on Components Manufactured or Installed By Boston Whaler** (not applicable to 13 Super Sport or 16 Super Sport models): Boston Whaler will repair or replace, at its sole discretion, any components manufactured or installed by Boston Whaler that are defective in factory materials and/or workmanship, which are reported within three (3) years from the date of sale to the original retail owner, and are not addressed in the specific warranties listed in paragraphs 1 or 4 or set out in the Exclusions paragraph below.
3. **One-Year Limited Warranty on Accessory Components for the 13 Super Sport and 16 Super Sport Models:** Boston Whaler provides the following Limited Warranty to the original retail owner of any factory-authorized accessory for the 2022 model year 13 Super Sport and 16 Super Sport, if purchased from an authorized Boston Whaler Dealer, authorized Boston Whaler website or any Boston Whaler affiliate and utilized under normal, non-commercial use (“Accessory”), subject to the remedies, exclusions, and limitations set out below. Boston Whaler will repair or replace, at its sole discretion, any Accessory that is defective in material or workmanship, which is reported within one (1) year from the date of sale to the original retail owner. Boston Whaler is not responsible for any defect and/or damage to the Accessory and/or the boat caused by improper installation, whether performed by the retail consumer, dealer or any other third party.
4. **One-Year Limited Warranty on Upholstered Items, Canvas, Teak, and Powder Coating:** Boston Whaler will repair or replace, at its sole discretion, any upholstered items, canvas, teak, and powder coating manufactured or installed by Boston Whaler that are defective in factory materials and/or workmanship and are reported within one (1) year from the date of sale to the original retail owner.
5. **Limited Engine Warranty:** Retail owners will be entitled to the limited engine warranty as provided in the

warranty manual from the engine manufacturer that was delivered to the original retail owner with his or her Boston Whaler Boat.

ENVIRONMENTAL POLICIES

In keeping with environmental policies and practices, Boston Whaler reserves the right to utilize reconditioned, refurbished, repaired or remanufactured products or parts in the warranty repair or replacement process. Such products and parts will be comparable in function and performance to an original product or part and warranted for the remainder of the original warranty period.

EXCLUSIONS

This Limited Manufacturer Warranty does not apply to any boat which has been salvaged or declared a total loss or constructive total loss for any reason not covered in this limited warranty. This warranty also does not apply to the following items:

- 1) Expenses for hauling out or transportation to and from the dealer or the Boston Whaler factory for warranty service.
- 2) Equipment or accessories which are not installed by Boston Whaler or which carry their own individual warranties, including but not limited to engines, engine components, batteries, propellers, controls, steering mechanisms, and electronics.
- 3) Damage, deterioration, discoloration or mold of cushions or cosmetic surface finishes, including scratches, gouges, chips, chalking, blistering, cracking, crazing, fading or oxidation of gel coat, stress lines, plated or painted metal and stainless steel finishes, plastics or acrylic materials, or anti-fouling bottom paint.
- 4) Windshield breakage and leakage.
- 5) Any Boston Whaler Boat initially sold at retail by a party other than an authorized Boston Whaler dealer.
- 6) Damage resulting from abuse, misuse, improper rigging and installation by an owner or any other person or entity not being an authorized dealer, accidents, overloading or powering in excess of the recommended maximum horsepower.
- 7) Failure of the owner to use, maintain, or store the boat as specified in the Boston Whaler owner's manual; and any other failure to provide reasonable care and maintenance. Normal wear and tear maintenance items are excluded from warranty coverage including but not limited to filters, bulbs, batteries, bungees, wiper blades, anchor rope, trailer finishes, tires, brakes, bearings and lights.
- 8) Any Boston Whaler Boat which has been altered or modified from Boston Whaler factory specifications, including penetration of the hull by anyone other than Boston Whaler factory personnel or Boston Whaler authorized dealer service personnel following factory specified procedures.
- 9) Damage resulting from use of improper trailer, improperly placed supporting bunks or slings, incorrect bunks placement, or improper boat lift or sling.
- 10) Any Boston Whaler Boat used for commercial purposes, which includes, but is not limited to, any for-profit or other revenue-generating uses.
- 11) Any representation or implication relating to speed, range, fuel consumption or estimated performance characteristics.
- 12) Any failure or defect caused by an act of nature resulting in damage, cost, or expense.
- 13) Any failure or defect arising from a previous repair made by a non-authorized service provider.
- 14) Any item exceeding the expressed coverage limits specified in any Boston Whaler Limited Manufacturer Warranty.

15) Failure of the owner to use, maintain, or store an Accessory in reasonable fashion; and any other failure to provide reasonable care and maintenance.

16) Any Accessory which has been altered or modified from Boston Whaler factory specifications.

17) Any Accessory not purchased from an authorized Boston Whaler Dealer, authorized Boston Whaler website, or authorized Boston Whaler affiliate. For a list of Boston Whaler's affiliates, please refer to www.brunswick.com.

18) Any Accessory used for commercial purposes, which includes but is not limited to, any for-profit or other revenue generating uses.

19) Any defect or repair requiring redesign of the Boat, except pursuant to the recall provisions of the United States Federal Boat Safety Act of 1971 or the recall laws of any other foreign jurisdiction.

ACCESS FOR SERVICE

The owner must provide Boston Whaler with a reasonable opportunity to repair, and reasonable access to the Boston Whaler Boat for warranty service. Warranty claims shall be made by delivering the Boston Whaler Boat for inspection to a Boston Whaler dealer authorized to service the product. If the owner cannot deliver the product to such a dealer, written notice must be given to Boston Whaler. Boston Whaler will then arrange for the inspection and any covered repair and the owner shall pay for all related transportation charges and/or travel time.

STATUTE OF LIMITATIONS

Without prejudice to your mandatory statutory rights, any action for rescission or revocation against Boston Whaler shall be barred unless it is commenced within one (1) year from the date of accrual of such cause of action, unless a longer period is prescribed by local law. This section shall not apply to Boston Whaler Boats purchased in Australia.

ASSIGNMENT OF COMPONENT WARRANTIES

Except as expressly set out herein, all warranties provided by the manufacturers and distributors of components, equipment, and parts on the boat (collectively "Component Manufacturers") are hereby assigned to the owner to the extent permitted by the Component Manufacturers, as the owner's sole and exclusive remedy with respect to such items.

OWNER'S OBLIGATIONS

To initiate a warranty claim, it is the responsibility of the owner to contact an authorized Boston Whaler dealer immediately after discovery of any defect, describe the nature of the problem, and provide a hull serial number, date of purchase, and name of selling dealer. The authorized dealer will notify Boston Whaler, who is solely responsible for determining and authorizing in writing the remedial action(s) to be performed at either an authorized Boston Whaler dealership chosen by Boston Whaler or at the Boston Whaler factory. The owner should notify Boston Whaler of any boat being repaired by an authorized Boston Whaler dealer which has been at the dealership for fifteen (15) days, or of any claimed defect which was not corrected after one repair attempt. Our privacy policies are available at www.bostonwhaler.com.

REGISTRATION & WARRANTY TRANSFER POLICY

The limited warranty coverage is activated by the authorized selling dealer registering the sale of a new Boat with Boston Whaler.

The Ten-year, Three-year, and One-year Limited Warranties are transferable to a subsequent owner, except

the One-year Accessory Warranty which is not transferrable, and this Limited Manufacturer Warranty will not transfer to any new owner of a boat which has been salvaged and resold, or resold after a declaration of a total loss or a constructive total loss, i.e., the cost of repair exceeds the value of the boat. The new owner must fill out and submit the online Boston Whaler warranty transfer form, accessible from www.bostonwhaler.com. A copy of the bill of sale will be required to submit with the form. The warranty transfer must be completed within 30 days of purchase.

MODIFICATIONS & SEVERABILITY

The terms and conditions contained herein, as well as those of any documents prepared in conjunction with the sale of this vessel may not be modified, altered or waived by any action, inaction, or representations, whether oral or in writing, except upon the expressed, written authority of a management level employee of Boston Whaler. The invalidity or unenforceability of any one or more of the provisions herein shall not affect the validity and enforceability of the other provisions.

SAFETY

It is your responsibility (as well as the responsibility of any other operator of this boat) to be familiar with and observe all local, state and federal laws, rules and regulations regarding boating, navigation and boating safety. You and any other operator of this boat should take a course in boating and boating safety before operation of this boat and should be completely familiar with all systems regarding safe operation of this boat. Personal flotation devices should be worn by each passenger in accordance with applicable standards and state and federal law.

THE FOLLOWING SECTION IS APPLICABLE TO AUSTRALIAN CONSUMERS ONLY

Boston Whaler Boats come with guarantees that cannot be excluded under the Australian Consumer Law. Retail owners are entitled to a replacement or refund for a major failure and compensation for any other reasonably foreseeable loss or damage. Retail owners are also entitled to have the goods repaired or replaced if the goods fail to be of acceptable quality and the failure does not amount to a major failure.

This Limited Manufacturer Warranty does not cover any expenses that retail owners may incur claiming the warranty. The benefits to retail owners given by this Limited Manufacturer Warranty are in addition to other rights and remedies of the consumer under a law in relation to the goods or services to which the Limited Manufacturer Warranty relates.

World Headquarters
100 Whaler Way, Edgewater, FL 32141
(386) 428-0057
www.bostonwhaler.com

**CALIFORNIA EVAPORATIVE EMISSIONS
CONTROL SYSTEM WARRANTY STATEMENT**

YOUR WARRANTY RIGHTS AND OBLIGATIONS

The California Air Resources Board and Boston Whaler, Inc. are pleased to explain the evaporative emission control system's warranty on your 2022 MY spark-ignition marine watercraft (SIMW). In California, new spark-ignition marine watercraft must be designed, built, and equipped to meet the State's stringent anti-smog standards. Boston Whaler, Inc. must warrant the evaporative emission control system on your spark ignition marine watercraft for the period listed below provided there has been no abuse, neglect or improper maintenance of your spark-ignition marine watercraft.

Your evaporative emission control system may include parts such as: carburetors, fuel tanks, fuel lines, fuel caps, valves, canisters, filters, vapor hoses, clamps, connectors, and other associated components.

MANUFACTURER'S WARRANTY COVERAGE:

This evaporative emission control system is warranted for three years. If any evaporative emission-related part on your spark-ignition marine watercraft is defective, the part will be repaired or replaced by Boston Whaler, Inc.

OWNER'S WARRANTY RESPONSIBILITIES:

- As the spark ignition marine watercraft owner, you are responsible for performance of the required maintenance listed in your owner's manual. Boston Whaler, Inc. recommends that you retain all receipts covering maintenance on your SIMW, but Boston Whaler, Inc. cannot deny warranty solely for the lack of receipts.
- As the SIMW owner, you should however be aware that the Boston Whaler, Inc. may deny you warranty coverage if your spark-ignition marine watercraft or a part has failed due to abuse, neglect, or improper maintenance or unapproved modifications.
- You are responsible for presenting your spark-ignition marine watercraft to a Boston Whaler, Inc. distribution center or service center as soon as the problem exists. The warranty repairs should be completed in a reasonable amount of time, not to exceed 30 days. If you have a question regarding your warranty coverage, you should contact Boston Whaler, Inc. at 1- 877-294-5645.

SIMW EVAPORATIVE EMISSIONS WARRANTY PARTS:

Fuel tank	Grade valves
Fuel feed hoses	Fuel fill deck plate with cap and pressure relief valve
Fuel line fittings	Hose clamps on fuel system components
Fuel demand valves	Fuel level vent valve

All other parts not listed that may affect the evaporative emissions control system.

Introduction

PRIVACY STATEMENT

Thank you for purchasing a boat or requesting information from Boston Whaler. This Privacy Statement is to inform you how we collect, use, disclose, and safeguard the personal information you provide to us through your purchases, requests for brochures, product registration cards, promotions, surveys, call centers, or other customer contacts. To see our full Privacy Policy and any updates, please visit www.bostonwhaler.com and select the Privacy Statement link. "Personal information" may include your name, age, mailing address, residential phone number, or e-mail address. It may also include income ranges, marital status, product or lifestyle preferences, and information concerning dealer service.

How we collect personal information: Our authorized dealer provided Boston Whaler or our company in the European Union with personal information collected at the time of your boat order/purchase with other product registration data and will continue to provide warranty and servicing information on your boat. We will send you customer satisfaction surveys which you may elect to return to provide us with information on your boat purchase and your servicing needs. Your personal information may be gathered by or shared with Boston Whaler's marketing providers and affiliated companies, who have comparable levels of privacy protection, for the purposes described in this statement. Boston Whaler, your dealer, and our marketing providers collect personal information when your request information about our companies and from surveys, promotions, contests, correspondence, your e-mails, telephone inquiries, web forms, and other communications. **How We Use and Disclose Personal Information:** Unless you advise us otherwise, Boston Whaler, our authorized dealers, affiliated companies, and our marketing providers may generally collect, use, disclose, hold, and file your personal information for the following purposes: (1) Providing goods, brochures, information, incentives, and/or services to you or on your behalf; (2) Fulfilling the terms of our limited warranty or other service obligation; (3) Facilitating recalls or service campaigns if necessary; (4) Reviewing goods and/or services provided to you in product, services, and marketing analyses; (5) Ensuring your satisfaction through surveys or other contacts; (6) Administration, billing, accounting, and collections; and protecting against fraud and error; and (7) Investigating a breach or a contravention of a law, complying with a subpoena, warrant, court order, or as required or otherwise permitted by law. Boston whaler will not sell your personal information or subject you to telemarketing or unsolicited e-mail.

Safeguards: We use security safeguards appropriate to the sensitivity of personal information to protect it from loss or theft, as well as prohibiting unauthorized access, disclosure, copying, use or modification of your personal information. These safeguards include restricted access to offices and equipment, security clearances, the use of passwords and/or encryption, publishing our privacy policy to appropriate personnel with instructions to act in accordance with its principles, and contractual provisions with our marketing agents and authorized dealers to follow the principles of our privacy policy.

Access and correction to your personal information: Subject to the exceptions provided by applicable law, we will provide, upon written request, your specific personal information collected in a form which is generally understandable. Your Personal Information is held by us and for us by our marketing agency, Rollick Company, who has contractually agreed to protect your information according to our privacy policies at the following addresses: Boston Whaler Inc., 100 Whaler Way, Edgewater, FL 32141. Please direct corrections, withdrawal of consent for specific purpose, complaints or other inquiries regarding personal information to: Rollick Company, 1078 Headquarters Park Drive, Fenton, MO, 63026; phone: (636) 343-9988, fax: (636) 326-3282. You can withdraw consent for us to use your personal information at any time or provide corrections upon providing to us a 30-day notice, unless withdrawing consent would impede the performance of legal obligations. We are required by law to provide you with information for product recall and other product safety relates purposes. The withdrawal of your consent may also adversely affect our ability to provide products and services to you and to maintain our relationship. Please note, notifying us will not result in withdrawing consent from your dealer, who should be contacted separately.

Obtaining consent: If any supplementary disclosure is required, we will obtain your consent for disclosure to other persons or organizations and for other purposes than stated herein, unless otherwise permitted by law.

Thank you for your business. We hope you have many years of wonderful boating experiences!

Introduction

Owner's Manual

Contained in the owner's packet (see below), this manual:

• Provides basic boating-safety information	• Details the boat's features and equipment
• Outlines the fundamentals of boat use	• Contains maintenance information

You must learn to operate this boat as well as read, understand, and use this manual. This manual does not give you a course in boating safety or how to navigate, anchor or dock your boat. Operating a power boat safely requires more skills, knowledge, and awareness than is necessary for a motor vehicle.

Owner's Packet

The owner's packet is a large, zippered bag that contains all manuals and instructional information for non-Boston Whaler equipment and systems on your boat. Read and retain this information.

Registration

Your Boston Whaler dealer will complete your new boat warranty registration. To warranty register this boat as a pre-owned Whaler, please visit the *Whaler Ownership* section on bostonwhaler.com.

Contact Us

Boston Whaler, Inc.

877-294-5645

www.bostonwhaler.com

Warranties

In addition to the Boston Whaler® Limited Warranty, each component and/or system on your boat has its own warranty that can be found with the specific information and manual for that component. These are included with your owner's information packet. Please locate, read, and retain the individual warranties.

Boating Information

A comprehensive background in boating can be found in the book, *Chapman Piloting: Seamanship & Small Boat Handling*, by Elbert Maloney. For boating courses in North America, contact one of the following organizations:

Organization	Website	Phone
Boat U.S. Foundation	boatus.org	800-336-2628
U.S. Coast Guard	uscgboating.org	—
U.S. Coast Guard Auxiliary	cgaux.org	877-875-6296
US Power Squadron	usps.org	888 367-8777
Canadian Coast Guard	ccg-gcc.gc.ca	800-267-6687
Canadian Power and Sail Squadrons	cps-ecp.ca	888-277-2628
Red Cross	redcross.org	800-733-2767
State boating offices		
Yacht clubs		
Outside of North America, contact your dealer or your governmental boating agency for assistance.		

THIS PAGE INTENTIONALLY LEFT BLANK

Safety Labels

The most important aspect of boating is safety. Although every effort is made to address the numerous issues regarding the safe use of this vessel, it is strongly recommended that you avail yourself of the training and knowledge available through boating-safety courses.

Mounted at key locations throughout this vessel are safety labels which advise the operator of imperative safety precautions to follow when operating and/or servicing equipment. Label categories are broken down by color and type.

DANGER

Denotes an immediate hazard exists that **WILL** result in severe personal injury or death.

WARNING

Denotes hazards or unsafe practices that **MAY** result in severe personal injury or death.

CAUTION

Denotes hazards or unsafe practices that **COULD** result in minor personal injury, product or property damage.

NOTICE

Denotes information that is important to know prior to operation and/or maintenance, but is not hazard related.

Below are black and white examples of safety callouts and labels which appear throughout this manual and must be observed when operating or servicing this vessel. Learn to recognize the category and understand the explanations before reading this manual.

DANGER

Denotes an immediate hazard exists that **WILL** result in severe personal injury or death.

WARNING

Denotes hazards or unsafe practices that **MAY** result in severe personal injury or death.

CAUTION

Denotes hazards or unsafe practices that **COULD** result in minor personal injury, product or property damage.

NOTICE

Denotes information that is important to know prior to operation and/or maintenance, but is not hazard related.

ATTENTION

Denotes information found in the owner's manual to call attention to the safe operation or certain features of this vessel.

Safe Boating Means

- Knowing the limitations of this vessel
- Following navigation rules (rules of the road)
- Be aware of people and objects in the water
- Not boating in water or weather conditions that are beyond the boat's and operator's capability
- Never operating the boat while under the influence of drugs or alcohol
- Being aware of passenger safety at all times
- Reducing speed when there is limited visibility, rough water, boats or structures

NOTICE

As a boat owner or operator, you are responsible for the safety of you, your passengers, and other boaters.

Boating in beautiful weather and calm water conditions can be a wonderful experience. But boating requires considerably greater skills than operating a land vehicle. Taking a boating course is the best way to prepare for a safe and enjoyable experience on the water.

- Take a USCG, U.S. Power Squadron or equivalent boating safety course. Call the Boat/U.S. Foundation at 800 336-2628 for information on available courses, or go to: www.boatus.org
- Get hands-on training on how to operate your boat properly.

Safe Boating Checklist

Before Departure

- Check weather forecast
- Check required documents are on board
- Check navigation charts are on board
- Check safety equipment is on board
- Ensure passengers and crew have received safety instructions on procedures, location, and use of safety equipment.
- Check drain plugs are installed
- Check bilge pumps are working and clean
- Check blower is working
- Check navigation lights are working
- Check horn is working
- Check fuel system has no leaks or fumes
- Check fuel filter is tight and clean
- Check power steering fluid is full (if applicable)
- Check steering system is working smoothly
- Battery connections and fluid levels (if applicable)
- File float plan with friend or relative

Trailing (if applicable)

- Check boat position is secure on trailer
- Check tiedowns are tight
- Check winch is locked
- Check trailer hitch is connected
- Check engine clearance in trailering position
- Check safety chains are attached
- Test lights, brake lights, and turn signals
- Adjust mirrors for trailering

After Return

- Dry and stow PFDs and other safety gear
- Fill fuel tanks (allow for expansion) to prevent condensation
- Check fuel system for leaks
- Check bilge pump is operating properly
- Check bilge is clean and leak free
- Check in with float plan notification person

General Considerations

- Know how this vessel handles under different conditions. Recognize your limitations and the boat's limitations. Modify speed in keeping with weather, sea, and traffic conditions.
- Instruct passengers on location and use of safety equipment and procedures.
- Instruct passengers on the fundamentals of operating this vessel in case you are unable to do so.
- You are responsible for passenger's actions. If they place themselves or the boat in danger, immediately correct them.
- Remember the *Rule of Thirds*: Use one third of the fuel for the trip outbound, one third for the return trip, and keep one third for reserve.

Maintaining Control

High-performance boats require intimate knowledge of each vessel's handling characteristics for safe, high-speed operation.

- Learn the effects of trim, steering and throttle changes at gradually increasing levels of speed.
- Approach full throttle while adjusting trim for safe handling of the vessel.

On the water there are no marked traffic lanes, no traffic signs or lights, and boats have no turn signals. The boat operator must keep her or his attention focused not only on what's ahead but what's on the left, right, and behind the boat.

The operator must always be alert to approaching boats (from the rear, right and left sides, as well as those ahead). There can be a variety of navigational hazards in the water including partially submerged debris, rocks, sand bars or dangerous currents, to name a few.

Your passengers are relying on you to operate and maneuver the boat safely so that they are not in danger of going overboard. If you turn too quickly or increase or decrease speed abruptly, your passengers are at risk of being thrown overboard or thrown about the boat.

When visibility becomes impaired because of

weather or time of day, use navigational lights to ensure other boats can see you. In addition, if high bow angle causes reduced visibility, slow down to allow sufficient time to react if an emergency occurs.

Boarding

- Board only one person at a time.
- Never jump into boat; step or climb.
- Load gear after aboard. Carrying gear while boarding can cause you to lose balance.
- Distribute weight evenly.
- Instruct passengers where to sit during on-plane operation to reduce the possibility of falling overboard during high speed maneuvers.
- If gear is not immediately needed, stow it in secure areas.
- Safety gear must be immediately accessible at all times.

Impaired Operation

WARNING

Control Hazard - Federal laws prohibit operating a boat while under the influence of alcohol or drugs. These laws are vigorously enforced.

The detrimental effects of alcohol and drugs are increased by wind, waves and sun, and will decrease your response time and ability to react in critical situations. Give special attention to the effects of alcohol and drugs while boating. No other single factor causes as many marine accidents and deaths. Death or serious injury and damage to personal and private property can result from being impaired while operating a boat.

Operator's Responsibilities

Your degree of enjoyment on the water depends on you, your equipment and other people who, like yourself boat responsibly. As a boat operator you should:

- Make sure that all occupants always wear a U.S. Coast Guard-approved life jacket while on the water.
- All boat operators should complete a boating safety course (a requirement in many states).
- All boat operators must become familiar with the proper operation of all vessel features prior to departure.
- Always maintain a safe speed.
- Be aware of conditions in every direction always when underway.
- Mind your wake. It can capsize a small boat or damage moored boats or other property. You are responsible for damage caused by your wake.
- Reduce speed and post a lookout to identify hazards when:
 - Visibility is impaired
 - In rough water
 - In congested waterways
- Display navigation lights between sunset and sunrise and during periods of restricted visibility, such as rain, fog, haze, etc.

WARNING

A qualified operator must be in control of the boat at all times. Do not operate the boat while under the influence of alcohol or drugs. Never operate this vessel at speeds which exceed the operator's ability to react if an emergency develops. At night, turn on the appropriate navigation lights and cruise at a reduced speed that allows you plenty of time to avoid dangerous situations.

WARNING

STABILITY HAZARD

- **Load boat properly. The manufacturer's load rating is the maximum weight allowed under normal conditions. Adjust downward if weather, water or other conditions are adverse.**
- **Allow passengers to ride only in areas that do not pose a hazard to themselves or the boat.**
- **Do not allow passengers to ride on the bow of a closed-bow boat.**
- **Do not allow several passengers to ride in the bow of a small open-bow boat, causing the boat to plow in the water.**
- **Do not allow passengers to ride on the stern cushion or gunwales.**
- **Do not overload the stern.**
- **Observe manufacturer's recommended on-plane seating locations.**
- **Passengers should remain seated while boat is moving.**

Personal injury hazard - Stay alert. Use of drugs, alcohol, or other substances which impair judgement poses a serious threat to yourself and others. The boat operator is responsible for the behavior of passengers.

Drowning hazard - Boats must carry one wearable personal flotation devices (PFDs) for every passenger on board. Boats must have at least one throwable life preserver.

Slipping hazard - Wet decks are slippery. Wear proper footwear and use extreme caution on wet surfaces.

Legally Mandated Equipment

Consult your national boating law enforcement agency. The following equipment is the minimum required by the United States Coast Guard (USCG) for a boat over 26 ft. (7.9 m) in length but less than 39.4 ft. (12 m) in length.

Personal Flotation Devices (PFD's)

One USCG approved Type I, II or III is mandatory for each person aboard.

One throwable Type IV device is also required to be onboard and located so that it is immediately available.

A Type V device is acceptable (see *PFD Classifications*, later in this chapter) if worn for approved use. Always wear a PFD when boating.

WARNING

There is rarely time to reach stowed life jackets in time of emergency. Boaters should always wear a properly fitting, approved life jacket when on the water.

Children and non-swimmers must wear PFDs at all times when aboard.

NOTICE

Depending on the state or country of operation, the operator of a vessel may be fined for failure to comply with local or national rules regarding PFD usage.

Fire Extinguishers

If there is no fixed fire extinguishing system installed, two size B-I or one B-II fire extinguisher(s) must be on board. If a fixed system is installed one B-I is required. The American Boat & Yacht Council (ABYC) recommends three A, B or C Type fire extinguishers be on board and located within easy reach of helm, outside of engine compartment(s), galley, and passenger area.

Sound-producing Devices

Ensure a sound producing device such as a horn or whistle is on board. Navigation rules require that a sound made by an audible device be capable of a four

second blast, and be audible for 1/2 mile (.80 km).

Visual Distress Signals

If you operate this vessel in coastal waters or on the Great Lakes, you must have visual distress signals for day and night use on board. At least three day/night combination pyrotechnic devices must be carried, readily accessible, in serviceable condition, and not be expired. Non-pyrotechnic substitutes include one orange flag for day-use and one electric S-O-S signal light for night-use. Store all pyrotechnic signals in a well marked, waterproof container.

Additional Required Equipment

Your vessel comes equipped with other mandated equipment such as an oil discharge and trash placard, navigation lights, certified marine sanitation device (option), and ventilation for your generator (option).

Additional Safety Equipment

In addition to the legally-mandated equipment, the following items are necessary for safe boating, especially if your boat will be out of sight of land.

- First Aid kit
- Charts/Maps
- GPS or LORAN
- Marine VHF radio
- Moisture repellent
- Mooring lines
- Fenders
- Waterproof flashlights
- High power spotlight
- Spare propeller
- Anchor
- Compass
- Manual bilge pump
- Spare keys
- EPIRB emergency positioning indicating radio beacon
- Boat hook
- Extra batteries
- Instruction manuals
- Lubricating oil
- Tool kit:
 - Screwdrivers, (Phillips and flat)
 - Pliers, (regular, Vise-grip, tongue and groove)
 - Wrenches, (box, open end, Allen and adjustable)
 - Socket set, (metric and U.S.)
 - Electrical tape and duct tape
 - Hammer
 - Spare parts kit, (spark plugs, fuses, etc.)

Carbon Monoxide (CO)

⚠ DANGER

- **Fumes from the engine(s), generator(s) and other equipment and appliances that burn fuel contain carbon monoxide. Carbon monoxide can kill you. Open all doors, hatches, curtains, and windows to allow fresh air to circulate and dissipate carbon monoxide present in enclosed spaces, especially when the boat is moored or anchored.**
- **Proper ventilation must be maintained, even during inclement weather to prevent dangerous levels of carbon monoxide build-up.**
- **Sleeping aboard a boat requires a working carbon monoxide detection system, preferably in each sleeping quarter.**

Carbon monoxide (CO) is an odorless, colorless, and extremely toxic gas produced by engines, heaters, stoves or generators. When inhaled it combines with hemoglobin in the blood, preventing absorption of oxygen and is unlikely to be noticed until the person is overcome.

Prolonged exposure to low concentrations or very short exposure to high concentrations can result in asphyxiation and death.

Symptoms of carbon monoxide poisoning include:

- Dizziness
- Ringing in the ears
- Unconsciousness
- Headaches
- Nausea

If symptoms are detected, get medical attention as soon as possible. Symptoms of CO poisoning are often confused with seasickness or intoxication, so those affected may not receive the medical attention they need.

The poisoning victim's skin often turns cherry red. If CO poisoning is suspected, have the victim breathe fresh air deeply. If breathing stops, resuscitate. A victim often revives, then relapses because organs are damaged by lack of oxygen.

Carbon monoxide (CO) can accumulate in dangerous concentrations anywhere in or around your boat including on back decks, swim platforms, or in water around generator exhaust. CO can remain in or around the boat at dangerous levels even if your engine is no longer running.

Remember:

- If you smell exhaust you are inhaling CO.
- Changing course and speed can improve ventilation.
- Adjusting the canvas enclosure and/or vents and other opening devices can improve ventilation.

To minimize the danger of carbon monoxide accumulation when the engine is running (or by use of fuel burning equipment):

- Do not idle the engine without moving the boat for more than 15 minutes at a time.
- Inspect the exhaust system regularly.
- Operate all fuel burning appliances, such as charcoal, propane, LPG, CNG or alcohol cooking devices in areas where fresh air can circulate.

Carbon Monoxide Detector

The carbon monoxide detector located on the forward galley cabinet will sound an alarm when dangerous levels of CO are detected. The detector is very sensitive and notifies you before dangerous amounts of carbon monoxide can accumulate which allows you to take measures to dissipate CO from the affected areas. Read and understand the warnings and recommendations presented in this chapter to help keep yourself and your passengers safe from carbon monoxide.

Testing:

At least once a week depress the *Test/Mute* button until the green LED turns on and release to determine if the detector is working properly.

The alarm triggers two alarm cycles (two sets of four beeps, 5 second silence between). The red LED will flash once every 5 seconds.

Maintenance:

Avoid spraying liquids directly on an alarm.

End of Life Signal

Your carbon monoxide (CO) detector is equipped with an end of life signal indicating the sensor used in the unit has reached the end of its service life and must be replaced. Refer to your unit's operation manual for end of life indication and further instructions. The end of life signal can be deactivated so that it does not go off. Deactivating the alarm is permanent and reactivation is not possible. Do not deactivate unless you have a replacement alarm available to install.

Carbon Monoxide Detector

Figure 1.7.1

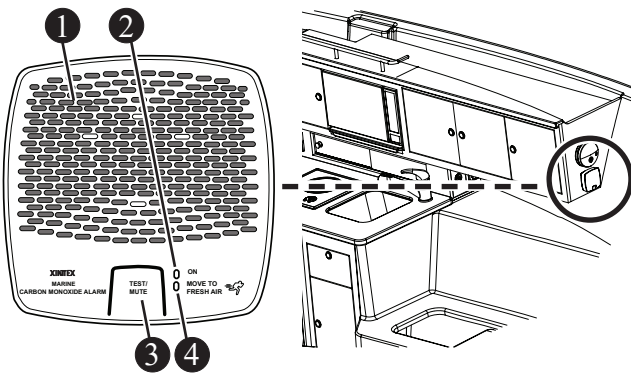

- ① ALARM HORN ③ TEST/MUTE BUTTON
- ② POWER INDICATOR ④ DANGER INDICATOR

⚠ DANGER

Even in rainy cold weather, ventilation must be maintained to avoid carbon monoxide poisoning. You will get wet and/or cold.

⚠ DANGER

Never ignore an alarm.

In the event the CO alarm activates:

- Evacuate enclosed areas immediately.
- Shut off fuel burning equipment or appliances
- Open hatches, doors, port lights, etc. to improve ventilation.
- If making way, head boat into the wind.

Carbon Monoxide Accumulation Scenarios Figure 1.7.2

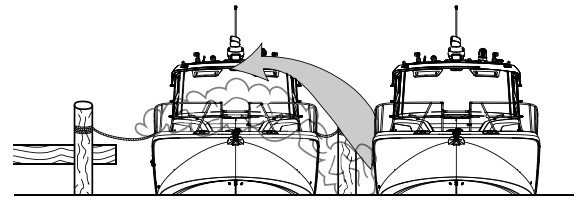

EXHAUST FROM OTHER BOATS

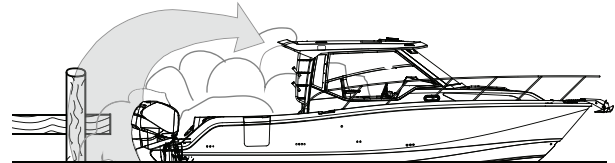

BLOCKAGE OF EXHAUST BY OBSTRUCTION

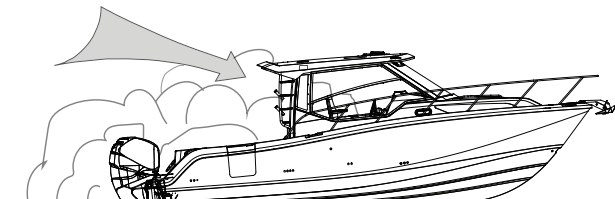

OPERATING AT A HIGH BOW ANGLE

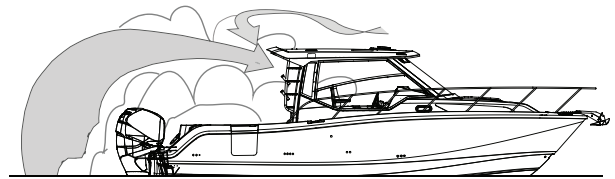

OPERATING AT SLOW SPEED OR WHILE IDLING (STATION WAGON EFFECT)

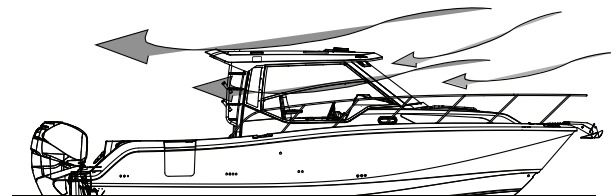

GOOD AIR FLOW
OPEN ALL HATCHES, PORT LIGHTS OR CANVAS OPENINGS TO LET FRESH AIR CIRCULATE.

Lifesaving Equipment

Even strong swimmers can tire quickly in the water and drown due to exhaustion, hypothermia, or both. The buoyancy provided by a personal flotation device (PFD) will allow the person who has fallen overboard to remain afloat with far less effort and body heat loss, extending survival time necessary to find and retrieve them.

PFD Requirement

One USCG approved PFD, Type I, II or III for each person aboard or being towed on water skis, tubes, etc.

The law requires that PFDs must be readily accessible, if not worn. Readily accessible means removed from storage bags and unbuckled.

NOTICE

Children and non-swimmers MUST wear PFDs at all times when aboard.

PFD Classifications

Listed below are the several different types of PFDs, each life jacket has different purposes, choose one that will suit your purpose.

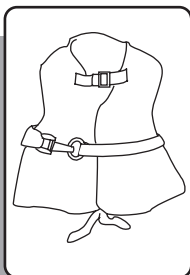

Type I, The off-shore life jacket is considered the most buoyant, it is designed to turn an unconscious person face up. Use in all types of waters where rescue may be slow, particularly in cold or rough water conditions.

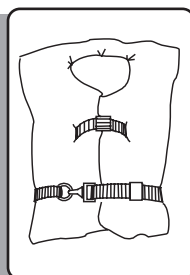

Type II, Near-shore life vest, a keyhole vest with flotation filled head and neck support is also designed to turn a person face up, but the turning action is not as pronounced. Use in calm inland waters or where quick rescue is likely.

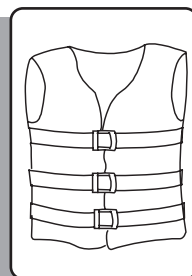

Type III, Flotation-aid Life vest is designed so that conscious wearers can turn face-up. Designed for comfort while engaged in water skiing or other forms of water activities.

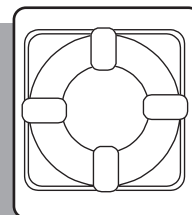

Type IV, Throwable Devices, horseshoe buoys, ring buoys and buoyant cushions are designed to be grasped, not worn.

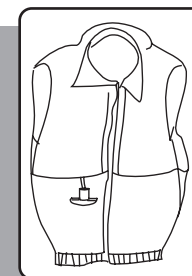

Type V, Special-Use devices, sailboat harnesses, white water vests, float coats, and hybrid vests which have minimum inherent buoyancy and an inflatable chamber.

Before purchasing PFDs, ensure that there is an attached tag indicating they are approved by the USCG or by your national boating law enforcement agency.

The operator is responsible for instructing everyone onboard on their location and use. The best precaution is to wear the PFD at all times while on the boat.

Emergency Situations

NOTICE

The law requires the owner/operator to assist any person or boat in distress as long as rendering assistance does not endanger the owner/operator, the passengers or the boat.

Prevention is the safest approach. We hope that you are never involved in an emergency situation, but if you are it is imperative that you react.

Medical Emergency

You may be far from professional medical help when you are boating. At least two persons on board your boat should be CPR certified, and should have taken a first aid course. Your boat should have a well stocked first aid kit on board. In many situations your radio will be your only link to reaching medical assistance. Keep the radio in working order and understand which channels are used for emergencies, these channels are constantly monitored and will be useful when situations arise. Cell phones can help in some areas, but they are limited and unreliable and should not be used in the place of a good VHF radio.

Water Rescue

In most situations a person that has fallen overboard will succumb to hypothermia if not rescued immediately. Life expectancy decreases as rescue time increases in water temperatures below 70°F (21.1°C).

There are three (3) steps that must be taken when a person has fallen overboard:

1. Returning to the Victim

- Immediately make everyone onboard aware that someone is overboard and keep the victim in sight.
- Slow the boat and keep pointing toward the person overboard. At night or in low light, point the best available light source at the person.
- Throw a life ring/preserver to the victim, even if they are wearing one it will serve as another marker.

2. Making Contact

- Stop or slow the boat and circle toward the person overboard.
- Try to approach heading into the wind or into the waves.

- Keep person overboard constantly in sight.
- When almost alongside, stop the engine in gear to prevent propeller windmilling.

3. Getting Back Aboard

- Try to reach the person overboard with a pole, or by throwing a life preserver. Never swim to them except as a last resort.
- Assist the person in boarding. Boarding should be done at the stern of the boat.
- If the person is injured or incapable of boarding by themselves, a rescuer should don a life preserver with a safety line and enter the water to assist the person onto the boat.
- Handle the person carefully, spinal injuries might have occurred and could be worsened by rough handling.
- Check for other injuries, render medical assistance immediately.

Unassisted Reboarding

The reboarding ladder can be deployed to accommodate a person reboarding the boat without assistance.

Fire

Fire is a serious boating hazard. Boats will burn quickly. Do not remain onboard and fight a fire for more than a few minutes. If the fire is out of control and cannot be put out with the fire suppression equipment onboard, abandon ship immediately.

The fumes released during a fire are toxic and should be avoided. Even after the fire has been extinguished, proper ventilation of the area is required to minimize exposure to harmful fumes.

DANGER

- **Fires can spread quickly. Your reaction to the fire is important. Have the proper fire fighting equipment close at hand, and in good working order to respond quickly.**
- **Small fire extinguishers have small discharge times. Aim at the base of the fire with a sweeping motion to maximize the use of the fire extinguisher contents.**

To lessen the danger of fire:

- Extinguish all smoking materials, shut off blowers, stoves, engine(s) and generator(s).
- Keep bilge area clean, oil and fuel spills should be cleaned immediately.
- If possible throw burning materials overboard.
- If fire is accessible, release the contents of the fire extinguisher(s) into the base of the fire.
- If the fire is in an enclosed compartment and you have an automatic fire extinguisher that has discharged in the compartment, wait 15 minutes before opening the compartment. Have extinguisher handy in case of a flare up.
- If possible, signal for help. Radio, visual, and audible signal should be used as needed. Also understand, that you must render assistance to any boater requesting help.
- If fire is out of control, grab all necessary survival gear, distress signals, put on personal flotation devices (PFDs) and prepare to abandon ship.
- If you do abandon ship, ensure the passengers have PFDs. Take a head count before entering the water and take another head count when in the water. Stay together.

Flooding, Swamping and Capsizing

In the event of flooding, swamping or capsizing:

Flooding

- Always wear your PFD, or have it within reach.
- If the bilge pump(s) have not automatically

turned on, switch them on immediately.

- Find the source of the flooding and determine the best fix.
- Keep the bilge pumps running until the flooding is under control.
- Call for assistance if the source of the flooding cannot be controlled.
- Head back to port if possible.

Swamping

- Always wear your PFD, or have it within reach.
- Swamping is usually a result of wave action, immediately get control of the helm and turn the boat into the waves.
- Swamping can also be caused by an overloaded boat.
- If the bilge pump(s) have not automatically turned ON, switch them ON immediately.
- The deck scuppers on this vessel are designed to drain the deck of water.
- Keep the bilge pumps running until the flooding is under control.
- Take a head count of all passengers.

Capsizing

- Capsized is when a boat is on its side or completely upside-down (usually as a result of wave action, improper loading or load shifting).
- If the boat will not right itself, get out of the water and climb onto the exposed hull.
- Do a head count for all passengers
- Stay together.
- Usually a capsizing will happen quickly and without warning.
- Use whatever is at hand to signal for help.

The chances of flooding, swamping or capsizing can be reduced by being aware of:

- Weather
- Water conditions
- Proper boat handling techniques
- Proper loading of the boat

Collision

In the event of collision:

- Stop the engine(s)
- Check on passengers
- If the bilge pump(s) have not automatically turned on, switch them on immediately.
- Determine amount of damage to boat structure.
- Call for assistance
- In the event of collision you are required to file an accident report. Contact a state enforcement agency or the nearest USCG office. If you are boating outside U.S. waters, consult the nation you are visiting for accident reporting requirements.

Propulsion, Control or Steering Failure

If there is a propulsion, control or steering failure:

- Stop the engine, (shut off at ignition or pull on the engine emergency stop switch)
- Drop anchor outside of the channel, if possible, to prevent drifting.
- Determine if the problem can be fixed or will assistance be needed.
- Call for assistance if needed.

When loss of propulsion or steering is noticed, your quick reaction is required to prevent further damage to your boat or injuries to your passengers.

Outboard engines require propulsion to control the direction the boat will take. Without propulsion, the steering is virtually useless. If you are in a congested waterway you will need to react quickly to warn others that you have lost power, propulsion or steering control and that assistance will be needed.

Grounding

Running aground may be avoided by paying attention to marker buoys or indicated by waves as they form into breakers when passing over a sand bar.

If you do run aground, the course of action depends on how hard the boat hits bottom and whether the boat remains stranded. If it is a simple touch, you may need only to inspect the lower drive of the engine and the hull of the boat. If possible do a thorough inspection before trying to get loose, throwing the boat into reverse before this is done may do more damage.

Distress Signals

Visual Distress Signals, (VDS)

- USCG regulations require boats in coastal waters and the Great Lakes to carry a visual distress signal (VDS) for day and night use, as well as appropriate for the time of operation. Exempt from the day signals requirement, but not night signals, are boats less than 16 ft (4.8 m), open sailboats less than 26 ft (7.9 m) boats participating in organized events and manually propelled boats.
- If you are required to have visual distress signals, at least three safety approved pyrotechnic devices in serviceable condition must be readily accessible. They must be marked with a date showing the service life which must not be expired.
- Carry three signals for day use and three for night use. Some pyrotechnic devices such as red flares, meet both day and night use requirements.
- Store pyrotechnic signals in a cool, dry location. An orange or red watertight container prominently marked *distress signals* is recommended.

Other recognized visual distress signals include:

- Flames in a bucket
- Code flags November and Charlie

- Black ball and square on orange background.
- Orange flag (certified)
- Electric distress light (certified) for night use
- Dye marker (any color)
- Person waving arms (slowly)
- U.S. ensign flown upside down

Audible Distress Signals, (ADS)

USCG regulations require one hand, mouth or power operated whistle or horn, audible for at least 1/2 mile.

Other recognized audible distress signals include:

- Radio communications (see *Radio Communications* below)
- Radio-telegraph alarm
- Position indicating radio beacon
- Morse Code S-O-S (3 short 3 long 3 short) sounded by any means.
- Fog horn sounded continuously.

Radio Communications

A radio is the boat operator's main method of receiving safety information and summoning aid. VHF-FM radio is the primary means of short range communication. Single sideband radio (SSB) is used for longer range communication.

VHF-FM channel 16 and SSB 2182 kHz are designated for emergency use. Such situations can be categorized as:

EMERGENCY

“MAYDAY, MAYDAY, MAYDAY,”- used when life or vessel is in imminent danger.

URGENCY

“PAN-PAN, PAN-PAN, PAN-PAN” (pronounced PAHN-PAHN)-used when a person or vessel is in some jeopardy less than indicated by a “MAYDAY” call.

“SECURITY, SECURITY, SECURITY” (pronounced SAY-CURE-IT-AY)-used for navigational safety or weather warning.

An emergency situation will be hectic and there will not be time to learn proper radio procedure. Learn what to do before you need to do it. If you hear a distress call, stop all radio transmissions. If you can directly assist, respond on the emergency frequency. If you cannot assist, do not transmit on that frequency. However, continue to monitor until it is obvious that help is being provided.

Weather

DANGER

Do not attempt to boat in severe weather conditions. Death or serious injury can occur. Get to shore before the weather turns bad.

Getting caught in severe weather is hazardous. Bad weather and/or rough sea or water conditions can cause an unsafe situation. Consult local weather services for up-to-date forecasts on weather and sea conditions. Television, radio, and internet can give you access to NOAA weather reports that will help you make a determination on where and when to get underway. Following are some weather related rules:

- Understand the design limitations of this vessel.
- Check the weather forecast and water conditions before leaving and while underway.
- Wear a personal flotation device (PFD)
- If bad weather is approaching, immediately seek a safe harbor.

WARNING

A sudden change in wind direction or speed or an increase in wave height indicates deteriorating weather.

NOTICE

Check the weather forecast and water conditions before leaving and while underway

Weather Warning Pennants
Figure 1.13.1

Small craft

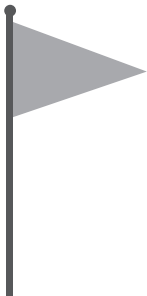

Red flag: Winds to 33 knots (38 mph).

Gale



Two red flags: Winds 34-47 knots (39-54 mph)

Storm

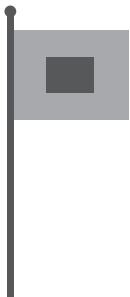

Square red flag with black box: Winds 48-63 knots (55-73 mph)

Hurricane



Two square red flags with black box: Winds above 64 knots (74 mph)

- If bad weather hits, seat passengers in cabin or cockpit deck. Head bow into the wind with enough power to maintain slow headway.
- If you encounter fog, determine your position, set a safe course, slow down and alert other boats of your presence with a sound signal.
- If a lightning storm approaches, the safest action is to dock and disembark. If you cannot return to shore, have passengers go inside the

cabin and remain there until the storm passes.

- Stay out of the water during a lightning storm. If caught swimming during a storm, get back into the boat and remain there until the storm passes. Remember that lightning can strike several miles away from the storm itself. Be aware of the storm location relative to your location and the direction the storm is moving.

Swimming, Diving and Water Skiing

Swimming

- Do not swim near a moving boat.
- Many areas prohibit swimming from a boat except in designated areas.
- Turn off engine in gear (to prevent propeller windmilling) before picking up swimmer.

Diving

Recognize and respect diving flags. Keep at least 30 meters (100 ft) away.

Diver's Flags
Figure 1.13.2

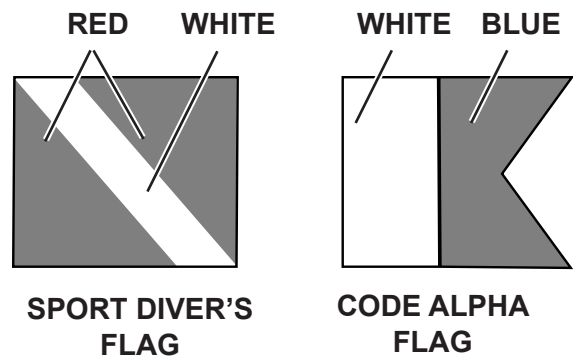

Sport Divers Flag - Red flag with diagonal white stripe marks a diver in the water.

Code Alpha Flag - Blue and white pennant designates boat being used in dive operations.

Water Skiing

- Always have two persons in the boat, one at the controls and one who can easily and continuously look at the skier.
- Insist that anyone who water skis must know how to swim.
- Insist that skiers wear approved Personal Flotation Devices (PFD's)
- Ski only in daylight when visibility is good.
- Never drive the boat directly behind a water skier. At 22 knots (25 m.p.h.), it takes only 5 seconds to overtake a fallen skier who was 60 meters (200 feet) in front.
- Ski only in areas where skiing is permitted.
- Observe local restrictions on length of tow line.
- Learn the signals to communicate with a skier. The skier is to control the boat through hand signals (see Figure 1.14.1).
- This vessel will handle differently while towing a skier. Experiment carefully to learn the difference.
- Skiers may start from the shore or dock, if boat traffic allows. When returning, pick up skiers from water. Do not ski back to shore or dock.
- Give immediate attention to fallen skiers.
- Keep a downed skier in sight and on the operator's side of the boat when approaching the skier. Never back up to anyone in the water.
- Turn off engine before picking up skier.
- If the skier suddenly releases the tow rope, it can backlash into cockpit. Spotters who are watching the skier must be aware of this fact and be prepared to take appropriate action to avoid injury.

Water Skiing Signals

Figure 1.14.1

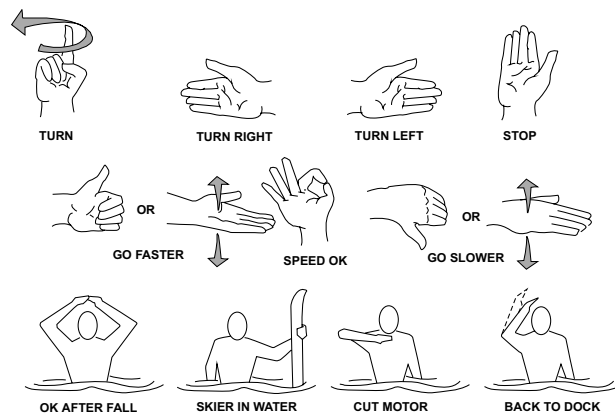

Turn – Arm raised, circle with index finger extended.

Turn Right – Extend arm out from body to the right.

Turn Left – Extend arm out from body to the left.

Stop – Raise arm with palm vertical and facing forward.

Faster – Thumb up or palm up, move hand up and down.

Speed OK – Raise arm and make OK symbol with thumb and index finger

Slow Down – Thumb down or palm down, move hand up and down.

OK After a Fall – Clasp hands together overhead.

Skier in Water – Extend one ski vertically out of water.

Cut Motor – Draw finger across throat.

Back to Dock – Pat top of head.

WARNING

SWIMMING/DIVING HAZARD

- **Keep clear of areas designated only for swimmers and skin divers. Recognize markers used for such areas.**
- **Never swim when there is lightning in the area.**

WARNING

SKIING HAZARDS

- **Skiers must use a safety approved personal flotation device (PFD).**
- **Ski only during daylight and in good visibility.**
- **Avoid shallow water, other boats, navigational aids and other obstructions.**
- **Keep at least 30 meters (100 ft) from other objects.**
- **Never drive directly behind a water skier.**
- **A competent observer must watch the skier at all times. A competent observer is a person that has the ability to assess when a skier is in trouble, knows or understands water skiing hand signals and is capable of helping a skier.**
- **Keep a downed skier in constant sight.**
- **Turn off engine in gear before you get close to person in the water.**
- **Never back up to anyone in the water.**
- **Use caution in boat when skier is being towed. Sudden release of tow rope can cause it to backlash into the cockpit.**

PERSONAL INJURY HAZARD

Use transom tow ring only to pull water skiers. Unless specified by the manufacturer, any other use, such as parasailing, kite flying, towing other boats, etc. may create too much stress on the tow ring, resulting in personal injury and/or equipment damage.

DANGER

PROPELLER SAFETY

- **Before starting the boat, walk to the stern and look in the water to assure there is no one near your propeller. People near propeller may not be visible from helm.**

DANGER

PROPELLER SAFETY (continued)

- **Never allow passengers to board or exit the boat from the water when engines are on.**
- **Educate passengers about the dangers of propellers**
- **Be especially alert when operating in congested areas; never enter swimming zones.**
- **Take extra precautions near boats that are towing skiers or tubers.**
- **Never permit passengers to ride on the bow, gunwale, transom, seatbacks, or other locations where they may fall overboard.**
- **Stop! If someone falls overboard. Slowly turn the boat around, and keep the person in sight as you approach. Turn your engine off first and then bring the person aboard.**
- **Never reverse this vessel to pick someone up out of the water.**

Towed Inflatables

ATTENTION

Ski tow pylons / tower / hardtop /ski eye tow points are not designed for use with tubes. The added stress of the tube may cause a dangerous recoil or damage the equipment. Damage to the pylon / tower / hardtop / ski tow eye is not covered by the boat or equipment manufacturer's warranty if misused. When towing inflatables/tubes, use both stern eye strong points with a tube tow harness to attach the tube tow rope.

Towed inflatable types, aka tubes, produce tremendous stress on the tow point and rope, far greater than devices like waterskis, kneeboards or wakeboards. When pulling a tube use both stern eye strong points in combination with a proper tube harness and tow rope. Parasails and kites should never be used with a recreational boat.

Engine Emergency Stop Switch

This vessel is equipped with an engine emergency stop switch. The switch is located at the helm. The engine emergency stop switch incorporates a shut-off switch, switch clip, lanyard and lanyard clip, which is clipped to the operator when running (see Figure 1.16.1). If an emergency arises and the engine must be shut down, a pull on the cord to release the clip from the stop switch will shut off the engine. This switch is designed to shut the engine off when the operator of the boat leaves the helm, either accidentally by falling into the boat or by being ejected overboard. . The lanyard should be long enough to prevent accidental activation. Do not let the lanyard become entangled. Accidental loss of power can be hazardous, particularly while docking or in heavy seas, strong current or high winds. Passengers and crew may lose balance and the boat may lose steering control. Should the operator fall out of the boat at planing speed, it may take several seconds for the engine and propeller to stop turning. The boat may continue to coast for several hundred feet, causing injury to anyone in its path.

WARNING

Wear lanyard at all times when operating boat. Use it to stop only in an emergency. Do not use it to shut off the engine during normal operation.

Engine Emergency Stop Switch
Figure 1.16.1

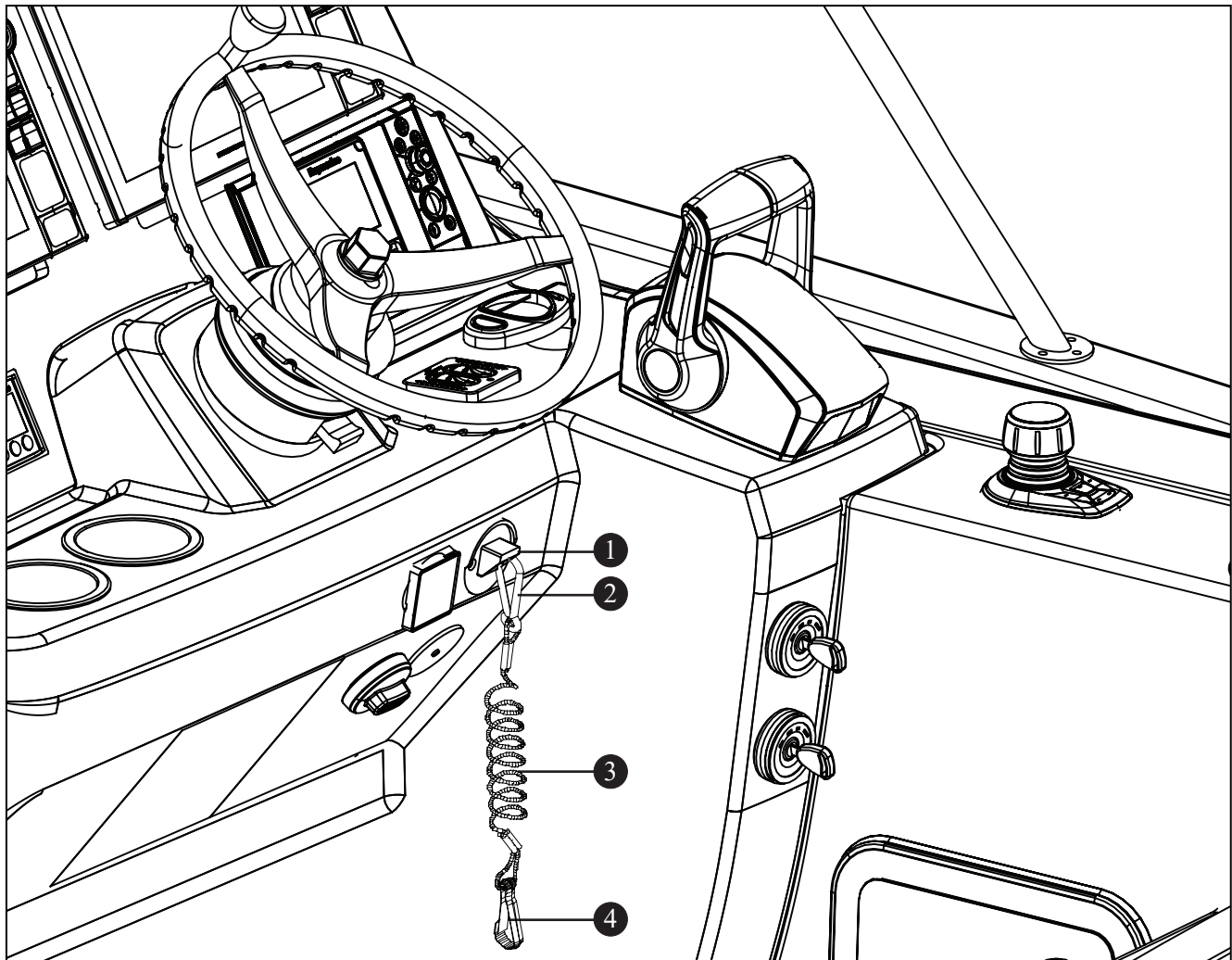

- 1 ENGINE EMERGENCY STOP SWITCH
- 2 HELM SWITCH CLIP

- 3 LANYARD
- 4 OPERATOR SWITCH CLIP

1st Mate™ Safety and Security System

The 1st Mate mobile app and wearable device integrate with Mercury systems to provide alerts, alarms, and distress communications designed to keep the captain and passengers safe. The system accommodates a captain and up to seven passengers. Features includes:

- Captain overboard event turns engine(s) off.
- Captain or passenger overboard event sounds alarm on the boat and via the app.
- Distress message capabilities to alert emergency contact(s) including location, heading, date and time of incident.
- Theft deterrent against boat-and-engine theft.

REFER TO OWNER'S PACKET FOR COMPLETE INSTRUCTIONS AND WARRANTY INFORMATION.

Float Plan

Float plans are important to you should you encounter problems on the water. A float plan should contain a description of this vessel along with any distinguishing features. It should describe where you will be boating, your departure time and estimated return. The number and names of passengers, and destination should also be noted.

The float plan should be given to a friend or relative, so they can give the information to a national boating agency like the USCG, in the event you do not return at the time specified on the float plan.

If there are any changes to the float plan they should be conveyed to the person holding the float plan. Once you return you should contact the person holding the float plan to let them know you are back.

Chart Course

To avoid boating in unsafe areas where there are underwater obstructions, shallow water, unnavigable conditions such as dangerous currents, and others, you must chart a course. This means having and using National Oceanic and Atmospheric Administration (NOAA) charts for coastal waters, observing and understanding all navigational aids, using the knowledge and guidance of experienced boaters, and being aware of the tides and times

where appropriate. If you are boating in an area you are unfamiliar with, proceed with caution and post a lookout to watch for hazards.

If an object is struck or if you run aground:

- Shut the engine off
- Check the hull for damage
- Check propeller for damage
- If aground, consider bottom grade before moving off, (damage to the hull and propellers could be worsened).
- Determine the tides and whether that change will help or hinder your situation.
- Do not have anyone other than a trained and competent service tow your boat.

WARNING

Hitting an object in or under the water or boating in dangerous currents can cause serious injury or death to occupants in the boat. You must know where the hazards are and avoid them. In uncharted waters, boat very slowly and post a lookout.

Environmental Considerations

Fuel and Oil Spillage

Regulations prohibit discharging fuel or oily waste in navigable waters. Discharge is defined as any action which causes a film, sheen or discoloration on the water surface, or causes a sludge or emulsion beneath the water surface. A common violation is bilge discharge. Use rags or sponges to soak up fuel or oily waste, then dispose of it properly ashore. If there is much fuel or oil in the bilge, contact a knowledgeable marine service to remove it. Never pump contaminated bilge overboard. Help protect your waters.

Excessive Noise

Many areas regulate noise limits. Even if there are no laws, courtesy demands that boats operate quietly.

Wake

 **WARNING**

Speed hazard, watch your wake. It might capsize a smaller craft. You are responsible for damage caused by your wake.

 **CAUTION**

Reduce speed in congested waterway. Be alert for no wake markers.

Power boat wakes can endanger people and vessels. Each power boat operator is responsible for injury or damage caused by the boat's wake. Be especially careful in confined areas such as channels or marinas. Observe *no wake* warnings.

Homeland Security Restrictions

Recreational boaters have a role in keeping our waterways safe and secure. Violators of the restrictions below can expect a quick and severe response.

- Do not approach within 100 yards, and slow to minimum speed within 500 yards of any U.S. Navy vessel.
- Observe and avoid all security zones. Avoid commercial port areas, especially those that involve military, cruise line or petroleum facilities. Observe and avoid other restricted areas near dams, power plants, etc.
- Do not stop or anchor beneath bridges or in channels.

America's Waterway Watch

In March, 2005, the United States Coast Guard officially launched *America's Waterway Watch* to encourage the boating public to report suspicious activities in our nation's ports and waterways. *America's Waterway Watch* simply asks anyone who works, lives, or recreates on the water to keep an eye out for suspicious activities. Anyone who spots such activity is asked to call the National Response Center's 24-hour hotline or 877-24WATCH (877-249-2824). If there is immediate danger to life or property call 911 or the USCG on marine channel 16.

Safety Label Locations

Mounted at key locations throughout the boat, safety labels advise the owner/operator of imperative safety precautions to follow when operating and/or servicing equipment. Do not remove or obstruct any label. Replace any label which becomes illegible (see *Label Locations* in this chapter).

Label Locations

IMPORTANT: Replace any damaged or illegible labels. Contact your dealer to obtain replacements.

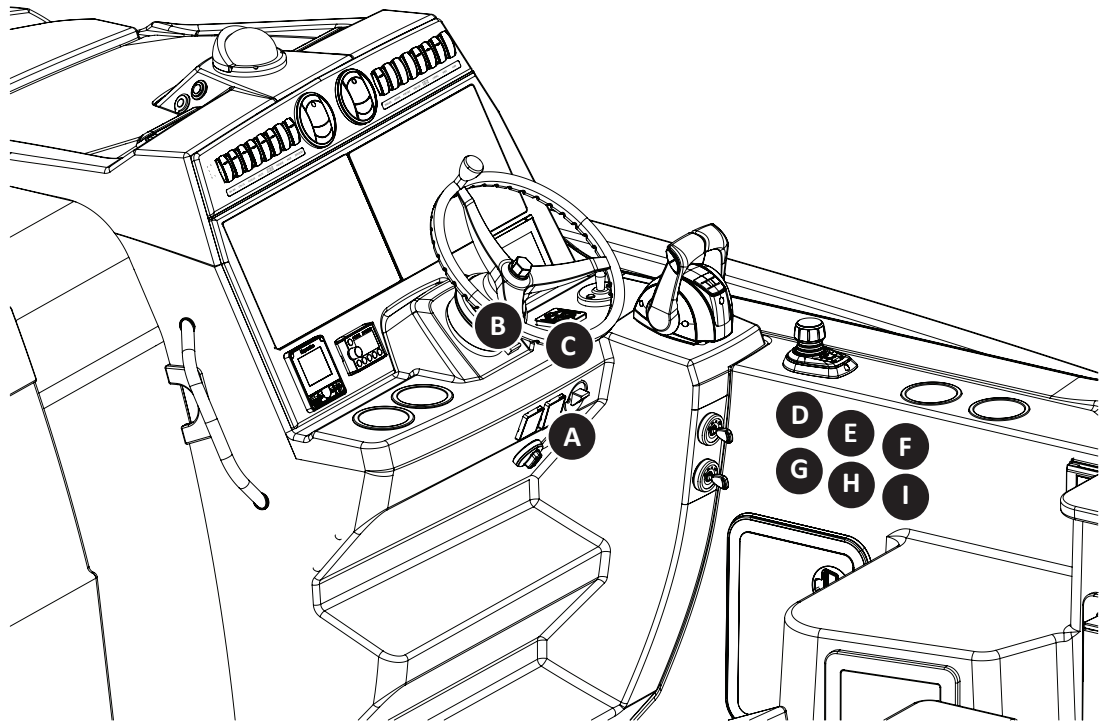

ATTACH LANYARD

A

2156485

B **WARNING**

Operating, servicing and maintaining a recreational marine vessel can expose you to chemicals including engine exhaust, carbon monoxide, phthalates, and lead, which are known to the State of California to cause cancer and birth defects or other reproductive harm. To minimize exposure, avoid breathing exhaust, service your vessel in a well-ventilated area and wear gloves or wash your hands frequently when servicing this vessel. For more information go to www.P65warnings.ca.gov/marine.

1795087

H Vessel's certification plate (see chapter 2, General Information).

C

LOOK BEFORE YOU PUMP!

USE E10 OR FUEL

Do not use any fuel containing greater than 10 percent ethanol (E10) in this equipment. It may cause damage or failure and is prohibited by Federal Law. For more information: www.LookBeforeYouPump.com

Ethanol Percentage

<10% OK NO 15% - 30% - 85%

2304853

D **WARNING**

ROTATING PROPELLER MAY CAUSE SERIOUS INJURY OR DEATH. SHUT OFF ENGINE WHEN NEAR PERSONS ARE IN WATER

1950698

E **EMISSIONS CONTROL SYSTEM INFORMATION**

MEETS 2022 MY CALIFORNIA EVAP EMISSIONS REGULATIONS FOR SPARK-IGNITION MARINE WATERCRAFT (SIMW)

MANUFACTURER: **BOSTON WHALER, INC.**

CALIFORNIA EVAP FAMILY: **NPNWPVSSLNT2**

EMISSION CONTROL SYSTEM: **SM**

2376350

F **THIS BOAT HAS BEEN DESIGNED FOR A MAXIMUM OUTBOARD ENGINE WEIGHT OF**

1400 lb / 635 kg

1774308

G **WARNING**

Carbon monoxide (CO) can cause brain damage or death.

Engine and generator exhaust contains odorless, colorless CO gas.

For additional information on CO poisoning, see *Owner's Manual*.

At first sign of CO poisoning, get to fresh air. Signs of CO poisoning include nausea, headache, dizziness, drowsiness, and unconsciousness.

1811368

I **WARNING**

Before activating Skyhook:

1. Check that no one is in the water.
2. Tell passengers not to enter water.

Skyhook makes the propellers spin. This can injure swimmers.

8M0034159

Label Locations

IMPORTANT: Replace any damaged or illegible labels. Contact your dealer to obtain replacements.

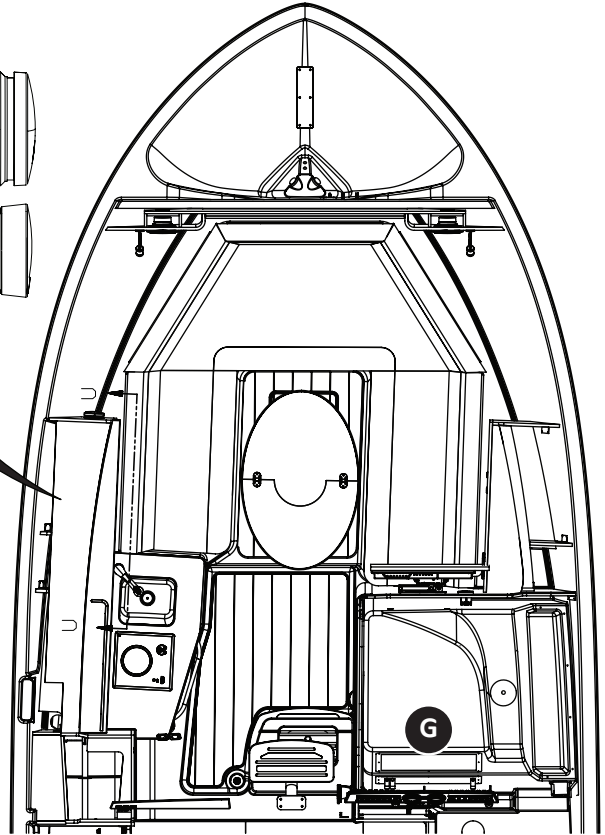
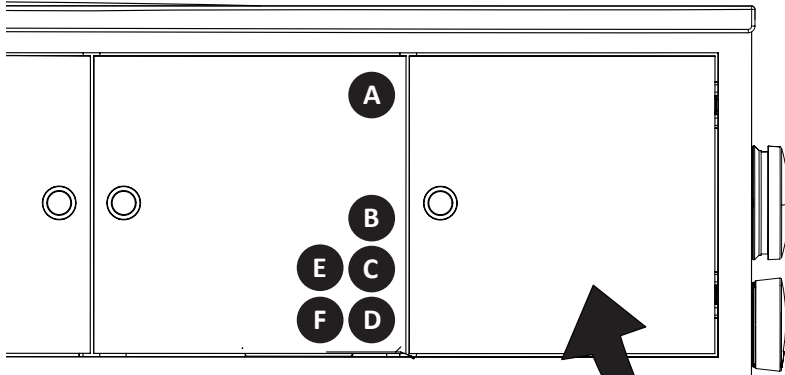

For optional generator, Canadian vessels

A **AVERTISSEMENT**

LES VAPEURS D'ESSENCE PEUVENT S'ENFLAMMER ET ENTRAÎNER DES BLESSURES OU LA MORT.

AVANT LE DÉMARRAGE DES MOTEURS / GÉNÉRATRICES

- VÉRIFIER LA CALE DU COMPARTIMENT MOTEUR POUR ESSENCE OU VAPEURS
- METTRE EN MARCHÉ LE VENTILATEUR PENDANT QUATRE (4) MINUTES
- VÉRIFIER LE FONCTIONNEMENT

FAIRE FONCTIONNER LE VENTILATEUR À UNE VITESSE INFÉRIEURE À LA VITESSE DE CROISIÈRE

2175075

CE vessels only

B **WARNING** **ELECTRICAL SHOCK HAZARD** **FIRE HAZARD** **READ OWNER'S MANUAL**

2025598

C THIS BOSTON WHALER WAS PRODUCED WITH ITEMS LISTED UNDER THE FOLLOWING PATENTS:

2088481

D COMBINATION BOAT HAWSE PIPE / ACCESSORY TRAY
U.S. PATENT# 7,343,870

2063995

E INTEGRATED BOW THRUSTER
U.S. PATENT# 7,765,946

2063996

F CONCEALABLE WORK STATION
U.S. PATENT PENDING

2088490

G **Save Our Seas**

It is *illegal* to dump plastic trash anywhere into the ocean or navigable waters of the United States. Violation of these requirements may result in civil penalty up to \$25,000, a fine of \$50,000 and imprisonment for up to five years.

<p>PLASTIC - Includes but is not limited to: plastic bags, styrofoam cups and lids, sixpack holders, stirrers, straws, milk jugs, egg cartons, synthetic fishing nets, ropes, lines, and bio or photo degradable plastics.</p> <p>GARBAGE - Means paper, rags, glass, metal, crockery (generated in living spaces aboard the vessel-what we normally call trash), and all kinds of food, maintenance and cargo-associated waste. "Garbage" does not include fresh fish or fish parts, dish-water, and gray water.</p>	<p>INSIDE 3 MILES (and in U.S. Lakes, Rivers, Bays and Sounds)</p> <p>PLASTICS DUNNAGE, LINING AND PACKING MATERIALS THAT FLOAT ANY GARBAGE EXCEPT DISHWATER/GRAYWATER/FRESH FISH PARTS</p>	<p>DUNNAGE - Material used to block and brace cargo, and is considered a cargo associated waste.</p> <p>DISHWATER - Means the liquid residue from the manual or automatic washing of dishes and cooking utensils which, have been pre-cleaned to the extent that any food particles adhering to them would not normally interfere with the operation of automatic dishwashers.</p>
	<p>3 TO 12 MILES</p> <p>PLASTICS DUNNAGE, LINING AND PACKING MATERIALS THAT FLOAT ANY GARBAGE NOT GROUND TO LESS THAN ONE SQUARE INCH</p>	<p>12 TO 25 MILES</p> <p>PLASTICS DUNNAGE, LINING AND PACKING MATERIALS THAT FLOAT</p>
	<p>12 TO 25 MILES</p> <p>PLASTICS</p>	

2029125

Label Locations

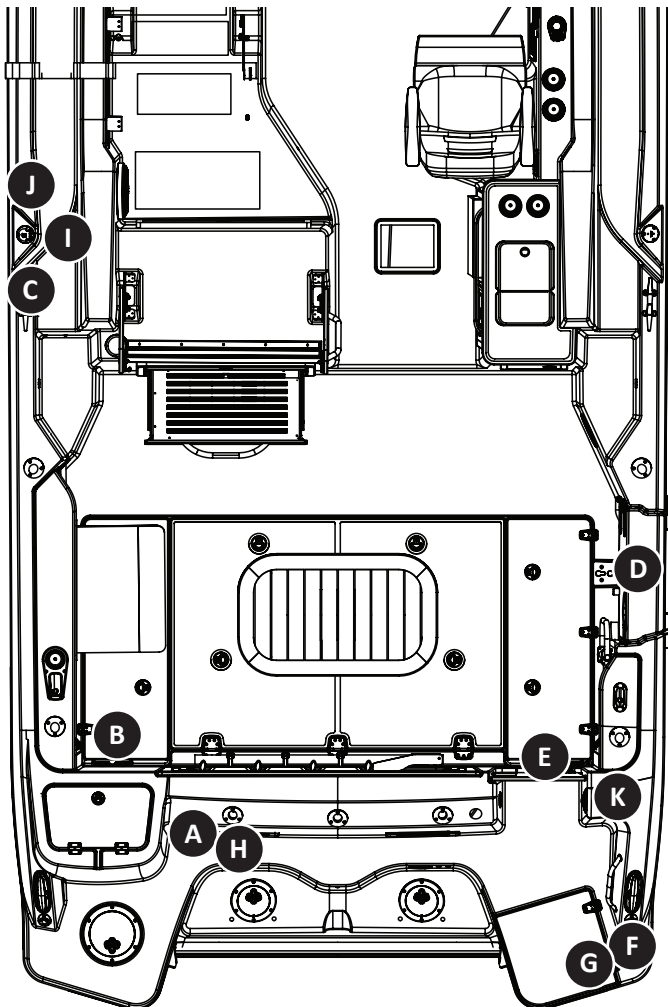

A SHORE POWER WARNING
To minimize shock hazard, connect and disconnect cable as follows:

1. Turn off boat's shore power switch
2. Connect cable at boat first
3. If equipped with polarity indicator which activates, disconnect and connect polarity
4. Disconnect at shore outlet first
5. Close inlet cover tightly

DO NOT ALTER SHORE POWER CABLE CONNECTIONS

0276808



2184707

B DANGER
INTERMEDIATE BREAKER FOR SHORE POWER. UNPLUG SHORE POWER BEFORE REMOVING COVER. WILL CAUSE PERSONAL INJURY OR DEATH

2029122

For Canadian vessels

C AVERTISSEMENT
LES FUITES DE CARBURANTS PRÉSENTENT UN DANGER D'INCENDIE OU D'EXPLOSION. INSPECTER RÉGULIÈREMENT LE SYSTÈME. VÉRIFIER LES RÉSERVOIRS DE CARBURANTS POUR DÉCELER DES FUITES OU DE LA CORROSION AU MOINS UNE FOIS L'AN.

MRP# 2175077 LEAKING FUEL

2175077

IMPORTANT: Replace any damaged or illegible labels. Contact your dealer to obtain replacements.

D WARNING
DOOR MUST BE SECURED IN THE CLOSED POSITION WHILE VESSEL IS UNDERWAY.

2063402

E DANGER
TRANSOM DOOR MUST BE CLOSED AND SECURE WHEN ENGINE IS RUNNING

2063385

F DANGER
Carbon monoxide (CO) can cause brain damage or death.
Engine and generator exhaust contains odorless and colorless CO gas.
CO will be around the back of the boat when engines or generators are running.
Move to fresh air if you feel nauseous, headache, dizziness or drowsiness.

1811367

G WARNING
Ask the Captain before entering the water. This boat has a feature called Skyhook, which automatically holds the boat in position.

When Skyhook is activated:

- the propellers rotate automatically;
- propeller rotation may not be obvious;
- the boat may suddenly move in any direction;
- the propellers can injure people in the water anywhere around the boat.

Unless the Captain gives you permission:

- do not go in the water; wind or water current can move swimmers into the propellers.
- do not sit or stand where you could fall overboard; you may lose your balance if the boat moves suddenly.

1903624

H WARNING
DO NOT LEAVE BOAT UNATTENDED WITH DOCKSIDE WATER HOSE CONNECTED. CONNECT DURING HEAVY WATER USAGE ONLY.

2028931

I WARNING
Avoid serious injury or death from fire or explosion resulting from leaking fuel. Inspect system for leaks at least once a year.

The use of fuels containing ethanol higher than 10% (E-10) can damage your engine or fuel system and will void the warranty. Never use (E-85).

2096004

J NOTICE
GASOLINE RECOMMENDATIONS
Minimum octane rating of 91 in the U.S. and Canada. Minimum octane rating of 96 outside the U.S. and Canada. Refer to engine manual for additional information.

2038447

Label Locations

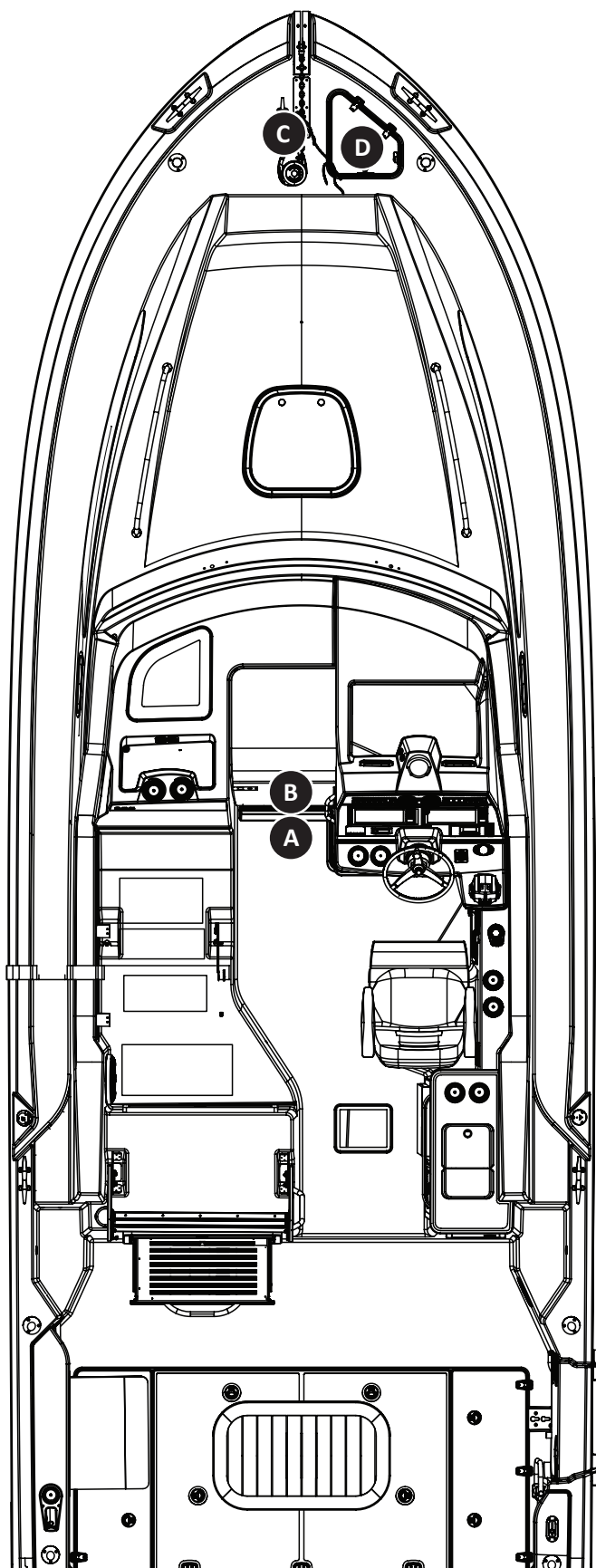

IMPORTANT: Replace any damaged or illegible labels. Contact your dealer to obtain replacements.

A

⚠ WARNING

RUNNING BOAT WITH DOOR OPEN COULD INDUCE EXHAUST FUMES INTO CABIN. SEE OWNERS MANUAL FOR INSTRUCTIONS CONCERNING CARBON MONOXIDE.

2028922

B

⚠ WARNING



Carbon Monoxide (CO) can cause brain damage or death. Carbon monoxide can be present in the cabin. Signs of carbon monoxide poisoning include nausea, headache, dizziness, drowsiness, and a lack of consciousness. Get fresh air if anyone shows signs of carbon monoxide poisoning. Get fresh air if carbon monoxide detector alarm sounds. Carbon monoxide detector must be functioning at all times.

1812911

C

⚠ DANGER

STAY CLEAR OF MOVING PARTS.

2028932

D

⚠ CAUTION

**AVOID PROPERTY DAMAGE
ENGAGE GYPSY LOCK AND ENSURE ANCHOR IS SECURED WITH LANYARD BEFORE GETTING UNDERWAY.**

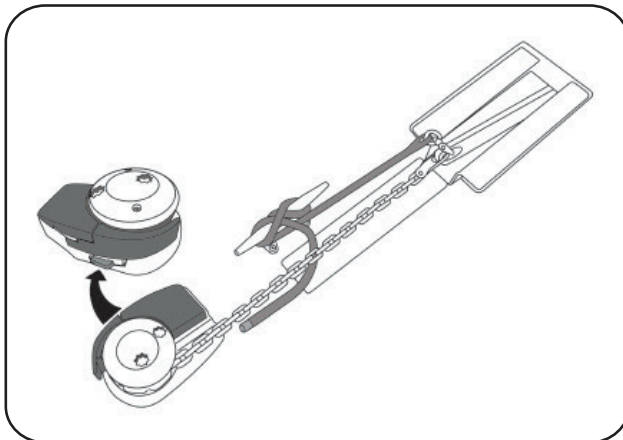

2147835

Label Locations

IMPORTANT: Replace any damaged or illegible labels. Contact your dealer to obtain replacements.

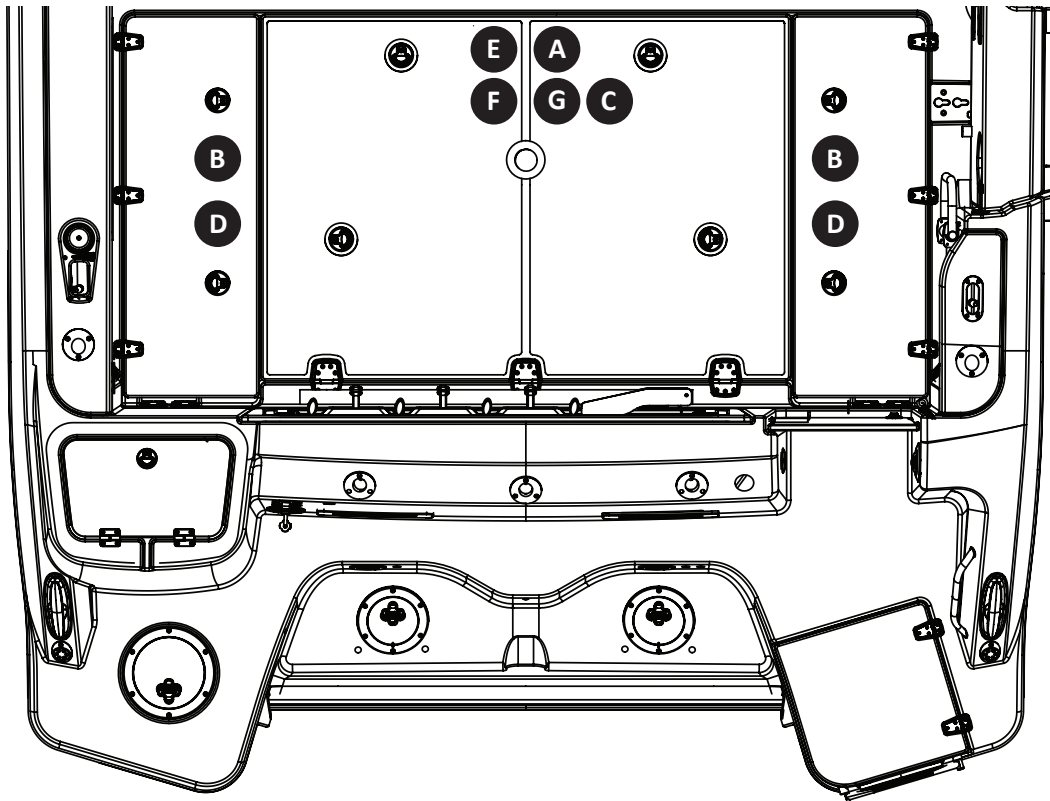

A

DISCHARGE OF OIL PROHIBITED

THE FEDERAL WATER POLLUTION CONTROL ACT PROHIBITS THE DISCHARGE OF OIL OR OILY WASTE INTO OR UPON THE NAVIGABLE WATERS OF THE UNITED STATES OR THE WATERS OF THE CONTIGUOUS ZONE IF SUCH DISCHARGE CAUSES A FILM OR SHEEN UPON OR A DISCOLORATION OF THE SURFACE OF THE WATER OR CAUSES A SLUDGE OR EMULSION BENEATH THE SURFACE OF THE WATER.

VIOLATORS ARE SUBJECT TO A PENALTY OF \$5,000.

2063375 or (2063413 CE ONLY)

B

⚠ CAUTION

AVOID INJURY
BOAT MOVEMENT MAY CAUSE LID TO FALL
KEEP HANDS AND FEET CLEAR OF EDGES WHEN
HATCH IS OPEN

1836858

C

⚠ WARNING

NO VENTILATION IS PROVIDED.
FUEL VAPORS ARE A FIRE AND EXPLOSION
HAZARD. TO AVOID INJURY OR DEATH, DO NOT
STORE FUEL OR FLAMMABLE LIQUIDS HERE.

1691003

D

⚠ CAUTION

ENSURE PROPER DRAIN PLUG INSTALLATION.
REMOVAL OF FISHWELL DRAIN PLUGS COULD
RESULT IN SWAMPING.

2049272

E

NOTICE

THIS BOAT IS EQUIPPED WITH AN OPTIONAL DIRECT
OVERBOARD DISCHARGE VALVE. DISCHARGING OF SEWAGE
DIRECTLY OVERBOARD IS FOR USE WHERE APPROVED ONLY

2063381

F

NOTICE

FIXED FIRE EXTINGUISHER SYSTEM MUST BE SUITED
FOR GROSS COMPARTMENT VOLUME OF 150 FT.

2028939

For Canadian vessels

G

AVERTISSEMENT

**NE STOCKEZ PAS D'ESSENCE OU
AUTRES LIQUIDES INFLAMMABLES À
CET ENDROIT. LA VENTILATION N'A
PAS ÉTÉ PRÉVUE POUR LES
VAPEURS EXPLOSIVES.**

2175076

Key to Symbols on Controls

Although not used in this manual, some of these symbols may be found on the controls, gauges, and hardware on this vessel. This page is to help you understand what the symbols mean.

					
ENGINE EXHAUST CONTROL	ENGINE	ENGINE START	ENGINE STOP	WARNING ELECTRICAL HAZARD	FIRE RISK
					
FUEL GENERAL	FUEL LEVEL	LEADED FUEL	UNLEADED FUEL	ENGINE COOLANT WATER JACKET TEMPERATURE	ENGINE OIL PRESSURE
					
BILGE PUMP	OUTBOARD DRIVE	OUTBOARD DRIVE TILT	PROPELLER	SEAWATER	ENGINE ROTATIONAL SPEED
					
BILGE BLOWER	SINGLE LEVER CONTROL	LIFT POINT / SLING LOCATION	LIFT POINT	RUNNING LIGHTS UNDER POWER	ROTARY CONTROL (WIDTH OF SYMBOL INDICATES INCREASE)
					
ANCHOR	ANCHOR LIGHT	INTERIOR LIGHT	HORN	WINDSHIELD WIPER AND WASHER	MAGNETIC COMPASS
					
PROPULSION SYSTEM TRIM BOW UP	PROPULSION SYSTEM TRIM BOW DOWN	PROPULSION SYSTEM TRIM	TRIM TAB TRIMMING OPERATION	FRESH WATER	GRAY WATER
					
OIL	BATTERY	CONTROL LEVEL OPERATION DIRECTIONS	WATER PUMP	ACCESSORY	NO OPEN FLAME NO SMOKING

THIS PAGE INTENTIONALLY LEFT BLANK

Construction Standards

Boston Whaler® is dedicated to creating a superior product which provides comfort, performance, safety, and reliability. All of our boats comply with United States Coast Guard safety standards and are designed, engineered, and manufactured in accordance with applicable recommendations and guidelines from the American Boat and Yacht Council (ABYC) and certified by the National Marine Manufacturers Association (NMMA).

Hull Construction

Boston Whaler hulls are constructed with our patented unibond-construction process (see Figure 2.1.1). This involves foam injection into a closed-mold system where the foam expands to fill all voids in the hull. When the finished product is pulled from the mold, the hull and deck are chemically bonded to form a solid, inseparable unit.

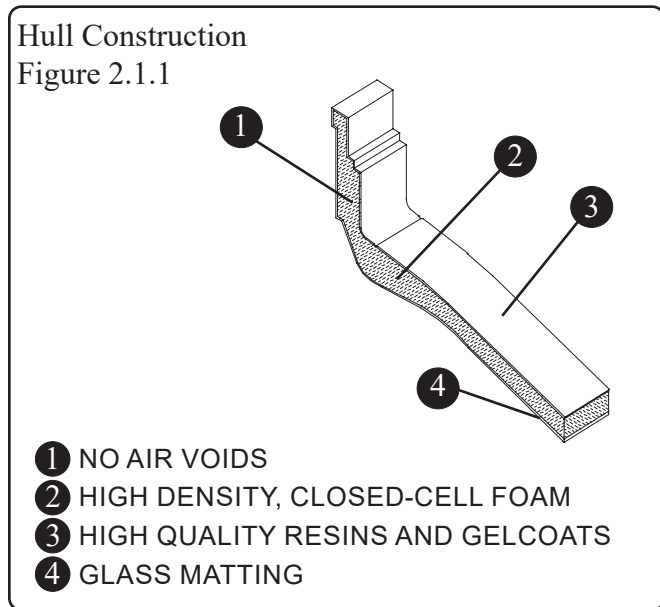

Hull Identification Number

The hull identification number is located on the starboard side of the transom (see Figure 2.1.2). This is the most important identifying factor on your vessel followed by the engine serial numbers. Be sure to reference these when contacting us about your vessel or engine.

Hull Identification Number (HIN)

Figure 2.1.2

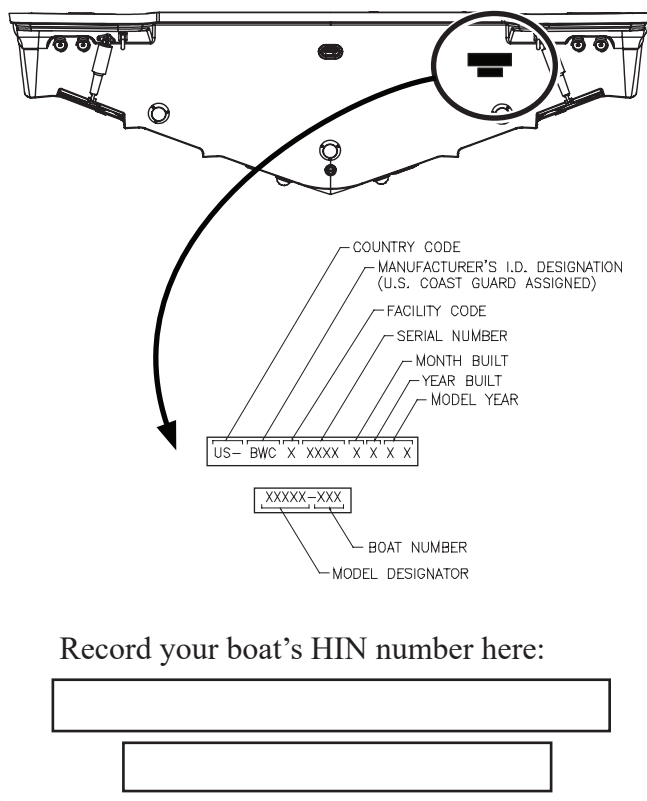

Vessel Servicing

When your boat requires service or maintenance work it should be taken to an authorized Boston Whaler dealer. To find a dealer in your area call 800-942-5379 (domestic/international).

In the unlikely event that a problem is not handled to your satisfaction, discuss any warranty related problems directly with the service manager of the dealership or your sales person. Give the dealership an opportunity to help the service department resolve the matter for you.

Manufacturer's Certification

All boats must comply with federal regulations regarding maximum capacities. The specifications and dimensions table, listed later in this chapter, indicates the maximum weight, number of persons, and maximum horsepower this vessel is rated to handle. Do not exceed these specifications.

⚠ DANGER

Never carry more weight or passengers than indicated for this vessel, regardless of the weather or water conditions.

The information present on the certification plate does not relieve the operator of responsibility. Use common sense and sound judgement when placing equipment and/or passengers in this vessel:

- Do not load to capacity in poor weather or rough water.
- The number of seats does not indicate how many people a boat can carry in poor weather and rough water.
- Above idle speed, all passengers should be seated on the seats provided.

Certification Plates

An **NMMA Certification** means that your Boston Whaler has been verified by the National Marine Manufacturers Association (NMMA) to be in compliance with applicable federal regulations and American Boat and Yacht Council (ABYC) standards.

A **Canada Compliance Notice** means that your Boston Whaler has been certified to comply with construction standards for small vessels by Transport Canada.

A **CE mark** means that your Boston Whaler has been certified with the applicable International Organization for Standardization directives.

An **Australian Builder's Plate** means that your Boston Whaler has been certified to comply with safety standards set by the National Marine Safety Committee.

Certification Plates

Figure 2.2.1

1



2

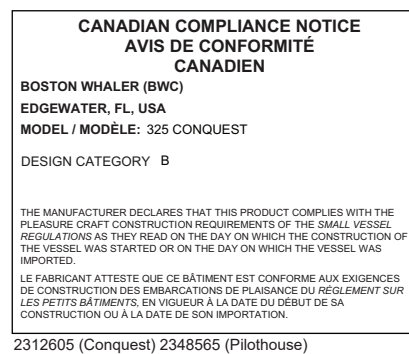

3

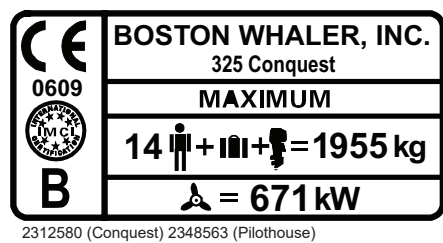

4



- 1 NMMA PLATE
- 2 CANADA CONFORMITY PLATE
- 3 CE MARK (INT'L) BUILDER'S PLATE
- 4 AUSTRALIAN BUILDER'S PLATE

Certification Design Category

A: A recreational craft given design category A is considered to be designed for winds that may exceed wind force 8 (Beaufort scale) and significant wave heights of 4 meters and above but excluding abnormal conditions, such as storm, violent storm, hurricane, tornado and extreme sea conditions or rogue waves.

B: A recreational craft given design category B is considered to be designed for a wind force up to, and including, 8 and significant wave heights up to, and including 4 m.

C: A watercraft given design category C is considered to be designed a wind force up to, and including 6 and significant wave heights up to, and including, 2 m.

D: A watercraft given design category D is considered to be designed for a wind force up to, and including 4 and significant wave heights up to, and including, 0,3 m, with occasional waves of 0,5 m maximum height.

The significant wave height is considered to be the primary factor for determining design category. Other parameters (e.g. meteorological) are descriptions of when these wave heights may be expected to occur.

NOTICE

The 325 Conquest is design category B

WARNING

Follow the recommendations listed on your capacity plate regarding the maximum amount of weight the boat can safely carry.

Power Capacity

The *Specifications and Dimensions* list on the following page indicates the maximum rated power listed for this vessel. Do not exceed this rating. The various engine types offered today are more powerful and require constant maintenance to stay at optimal performance. The operator must read all information regarding the safety features, warning notices and maintenance schedules for safe operation of the engines.

The engines on this vessel has been tested and proven to be best suited for general use under normal conditions and load.

If you are re-powering your Boston Whaler, you should pay particular attention to the maximum/minimum horsepower and maximum safe engine weight load this vessel is rated for. There is a maximum engine weight label located starboard of the helm seat.

NOTICE

The 325 Conquest is designed for a maximum outboard engine weight of 1400 LBS (635 kg).

WARNING

- Do not exceed the maximum engine power rating stated on the certification plate.
- Use caution while accelerating. Make sure passengers are safely seated in designated areas of the boat and all gear is stowed securely.

NOTICE

Always adjust the speed and direction of the craft to the varying sea conditions.

Chapter 2 • General Information

Specifications and Dimensions (measurements are approximate and subject to variance)

Overall length	33'11 ¹ / ₈ " (10.34 m)	Swamped capacity	2300 lbs (1043 kg)
Length of hull (center line)	32'3" (9.83 m)	Maximum engine weight	1400 lbs (635 kg)
Trailerable length	35'6-5/8" (10.84 m)	Max weight (passengers, engines, gear²)	4310 lbs (1955 kg)
Bridge clearance (hardtop)	9'3" (2.81 m)	Persons	14
Bridge clearance (radar)	10'7" (3.23 m)	Maximum horsepower	900 HP (671 kW)
Beam	10'8" (3.25 m)	Minimum horsepower	600 HP (447 kW)
Draft (hull only)¹	26" (.66 m)	Fuel capacity	300 gal (1135 L)
Weight (dry, no engines)	10500 lbs (4762 kg)		
Weight (fuel,water,engines)	14290 lbs (6482 kg)		

¹ Optional equipment and loading of the boat affects the draft measurements. Follow the recommendations listed on your capacity plate regarding the maximum amount of weight this vessel can safely carry.

² Exceeding maximum weight affects boat performance. Do not exceed the weights listed on the capacity plate.

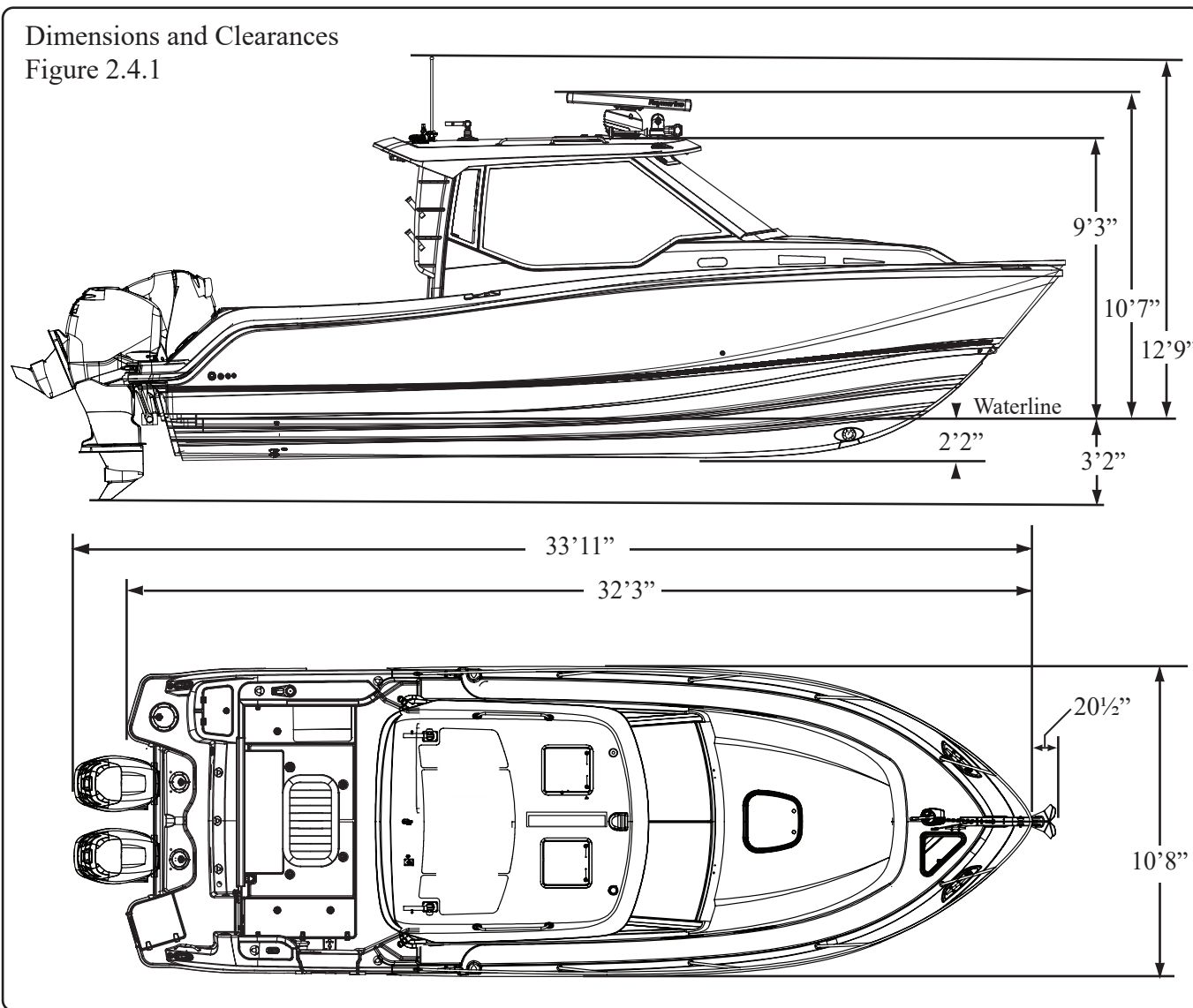

Deck Occupancy

Figure 2.5.1

Working deck



This area is intended for occupation only while mooring, anchoring, loading/unloading or when the boat is at rest.

Accommodation deck



Movement in this area should be done with extreme caution while the boat is underway. A sudden shift in boat direction can cause a loss of balance and lead to injury or death.



Do not stand or walk in this area. Serious injury could result. If necessary, stand or walk only where non-skid is applied.

DANGER

Be aware of your footing while the boat is underway, slipping or falling could result in serious injury or death, especially if the boat is in motion or in rough seas. Keep the accommodation deck clean, so if movement is necessary it will be free of obstruction.

WARNING

- Gelcoat surfaces are slippery when wet. Use extreme caution when walking on wet surfaces.
- Never occupy the working decks while the boat is underway.
- Use care when waxing to ensure that walkways are not made slippery.

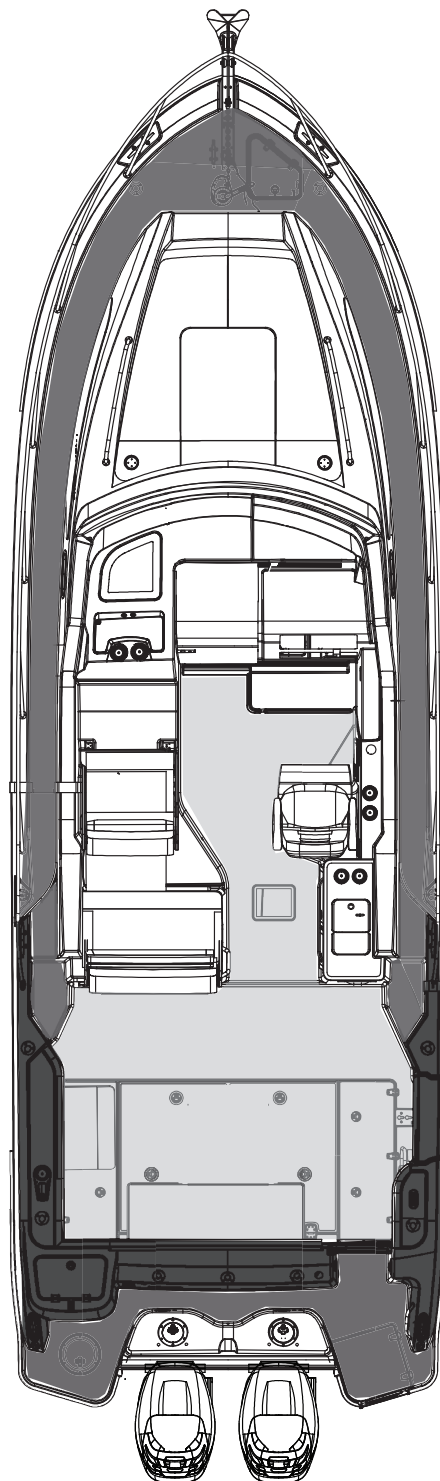



Recommended Occupant Locations

Seating and On-plane Occupant Locations

Figure 2.6.1

⚠ WARNING
NEVER allow passengers to ride in an area (i.e. bow, gunwales, transom, etc. that will pose a hazard to themselves or the boat.

-  = Recommended seating locations
-  = Recommended standing locations

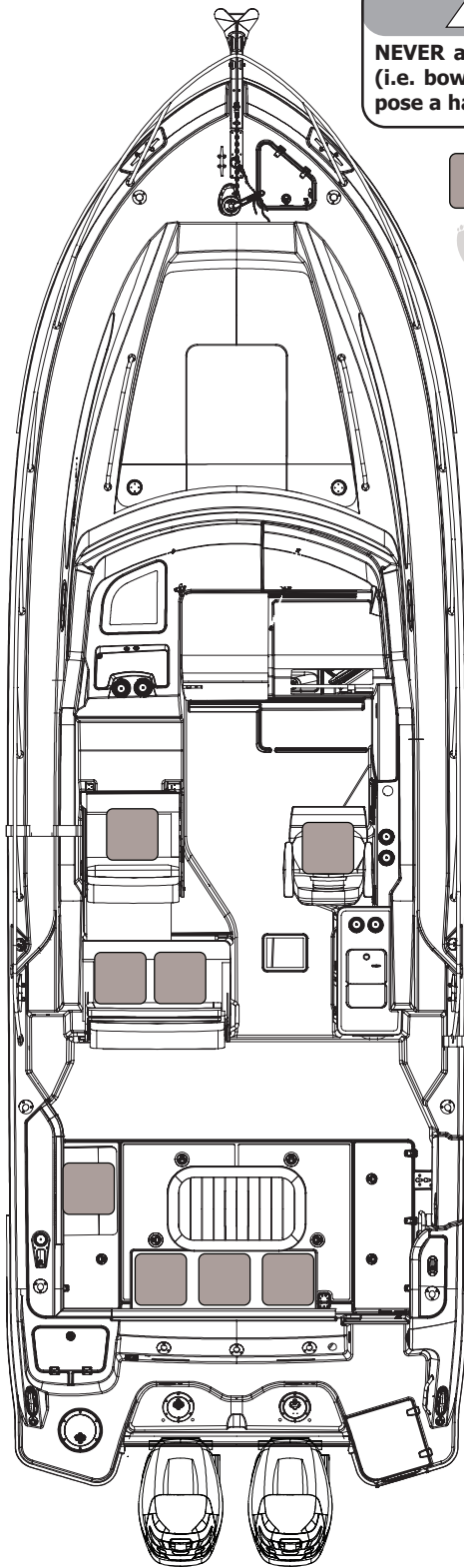

Recommended occupant locations while moored, at idle or under 5 mph

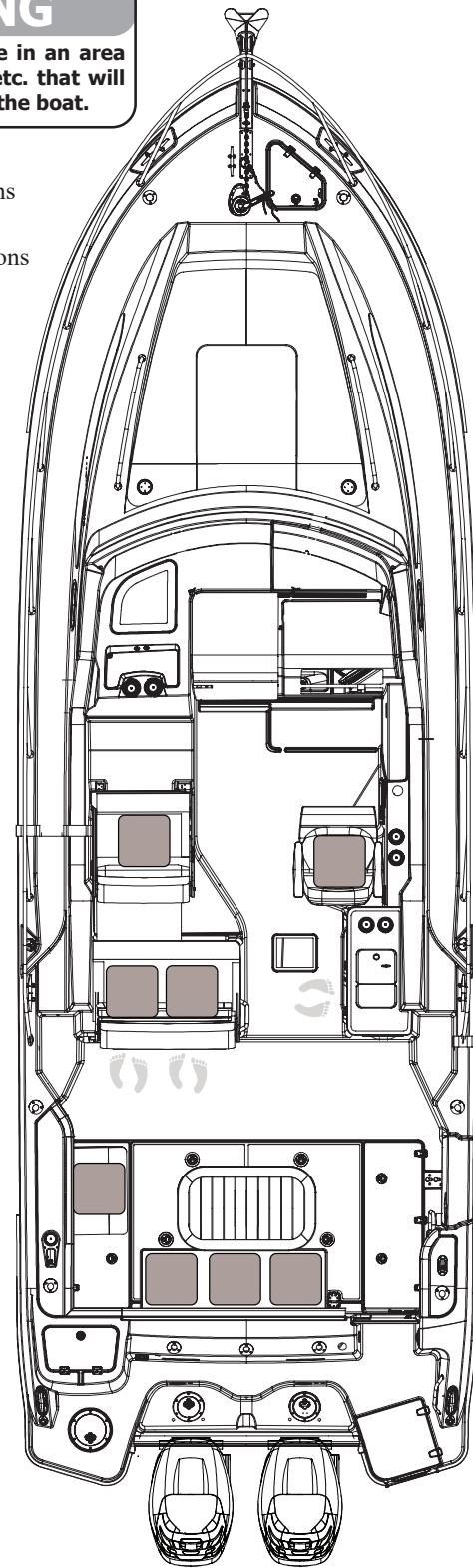

Recommended occupant locations on-plane

NOTE: Hardtop not shown.

NOTE: There are additional passenger locations below deck.

Location of Thru-hull Fittings

Thru-hull Fittings

Figure 2.7.1

- ① ANCHOR LOCKER DRAIN
- ② GALLEY SINK DRAIN
- ③ FISHBOX PUMPOUT
- ④ BILGE PUMP DISCHARGE
- ⑤ LIVEWELL DRAIN
- ⑥ GENERATOR EXHAUST (OPTION)
- ⑦ BILGE PUMP DISCHARGE
- ⑧ FISHBOX PUMPOUT
- ⑨ GYROSCOPIC STABILIZER DRAIN (OPTION)
- ⑩ FISHBOX DRAIN
- ⑪ PREP STATION SINK DRAIN
- ⑫ DRIP PAN DRAIN
- ⑬ A/C CONDENSATION DRAIN
- ⑭ HELM A/C DISCHARGE (OPTION)
- ⑮ WATER HEATER RELIEF (OPTION)
- ⑯ CABIN A/C DISCHARGE (OPTION)
- ⑰ SUMP DRAIN
- ⑱ BILGE PUMP DISCHARGE
- ⑲ SINK DRAIN
- ⑳ FISHBOX DRAIN
- ㉑ RAW WATER PICKUP
- ㉒ WASTE SYSTEM OVERBOARD DISCHARGE
- ㉓ GENERATOR PICKUP (OPTION)
- ㉔ THRU-HULL TRANSDUCER (OPTION)
- ㉕ GYROSCOPIC STABILIZER PICKUP (OPTION)
- ㉖ HEATER VENT (OPTION)
- ㉗ A/C PICKUP
- ㉘ FISHBOX VENT

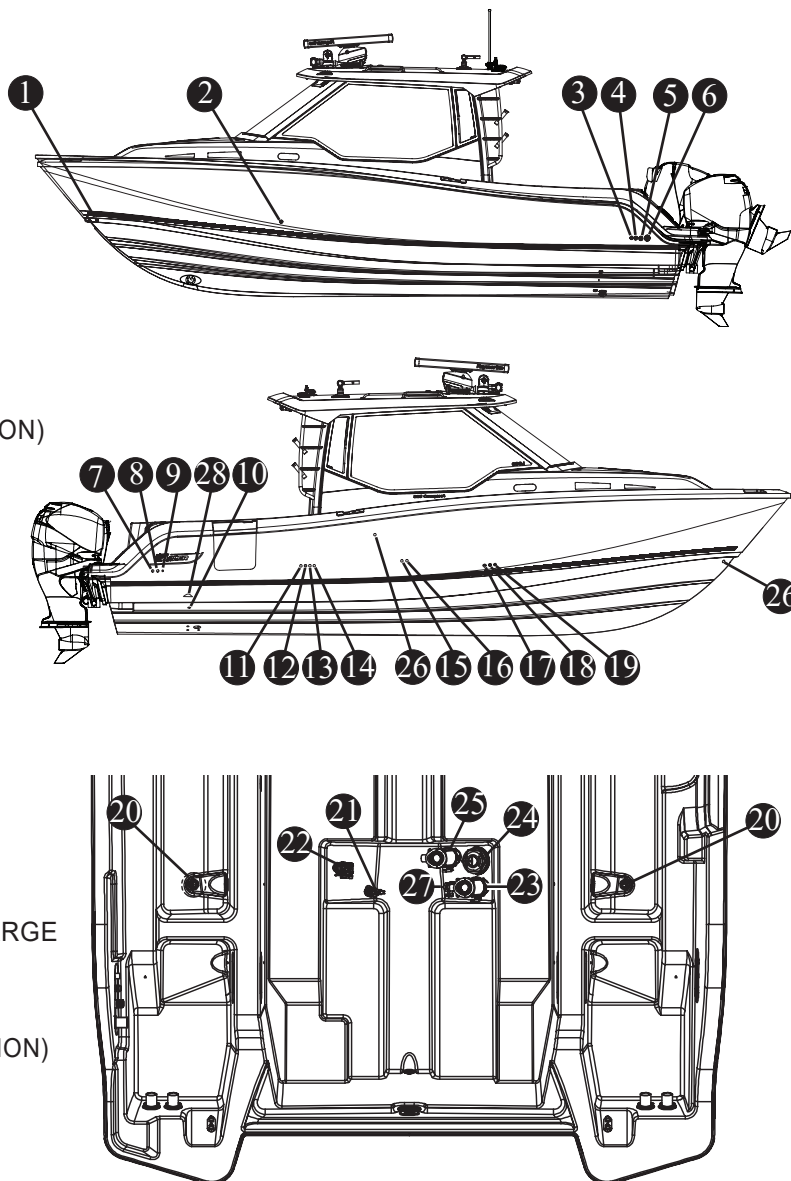

NOTICE

- The deck drains provide self-bailing capabilities while the boat is static in the water and no passengers on board. This feature prevents the accumulation of water in the cockpit.
- Depending on the type of boat, you may have underwater fittings that need drain plugs. Garboard drain plugs and fishbox drain plugs need to be in place before the boat goes into the water. Any fitting that will be underwater needs to be plugged or the seacock needs to be closed.
- Through hull fittings and deck drain scupper flaps should be checked for proper seal annually. When the boat is in the water the underwater fittings can be checked for dripping. It is recommended that the underwater fittings be removed, cleaned and resealed every other year.
- If the through hull fittings need to be replaced, it is recommended that an authorized Boston Whaler dealer perform this type of repair. Through hull fittings that are improperly installed can cause premature hull failure and may void the Boston Whaler limited warranty.
- A standard 1" Snap-Tite plug can be used to replace drain plug(s) in this vessel. It is recommended you carry spare plugs in the event that the drain plug(s) become lost or damaged.

Features

Deck

Figure 2.8.1

- ① ANCHOR
- ② BOW RAIL
- ③ CLEAT
- ④ WINDLASS
- ⑤ DECK HATCH
- ⑥ SKYLIGHT
- ⑦ CABIN ENTRY DOOR
- ⑧ CONVERTIBLE LOUNGE SEATING
- ⑨ FUEL FILL
- ⑩ FOLD-DOWN SEAT
- ⑪ MECHANICAL ACCESS HATCH
- ⑫ HAWSE PIPE W/CUPHOLDER
- ⑬ FOLD-DOWN BENCH
- ⑭ LIVEWELL
- ⑮ TRIM TAB ACCESS PLATE
- ⑯ ANCHOR LOCKER
- ⑰ PREP STATION WITH SINK
- ⑱ FISHBOX
- ⑲ HAWSE PIPE
- ⑳ REBOARDING LADDER
- ㉑ GRAB RAILS
- ㉒ FUEL TANK INSPECTION COVER
- ㉓ WASTE
- ㉔ WATER
- ㉕ POP UP CLEAT

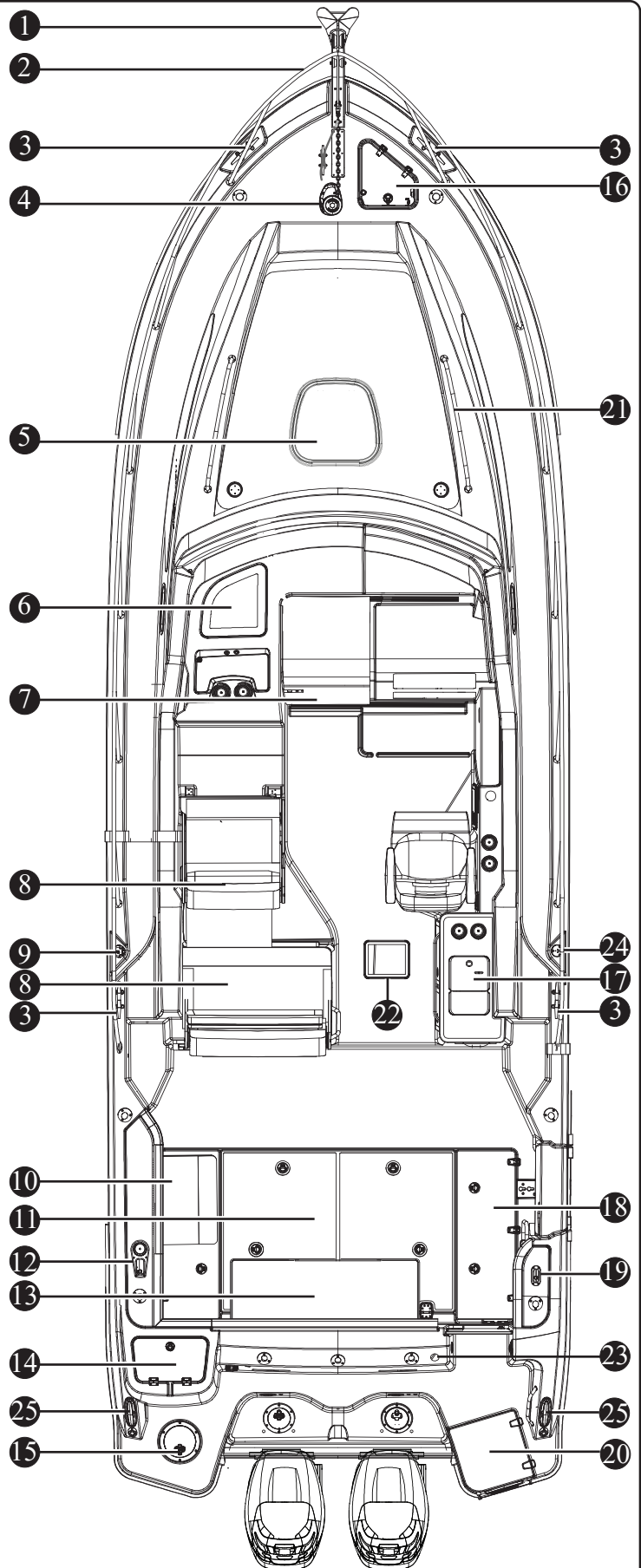

Features

Cabin
Figure 2.9.1

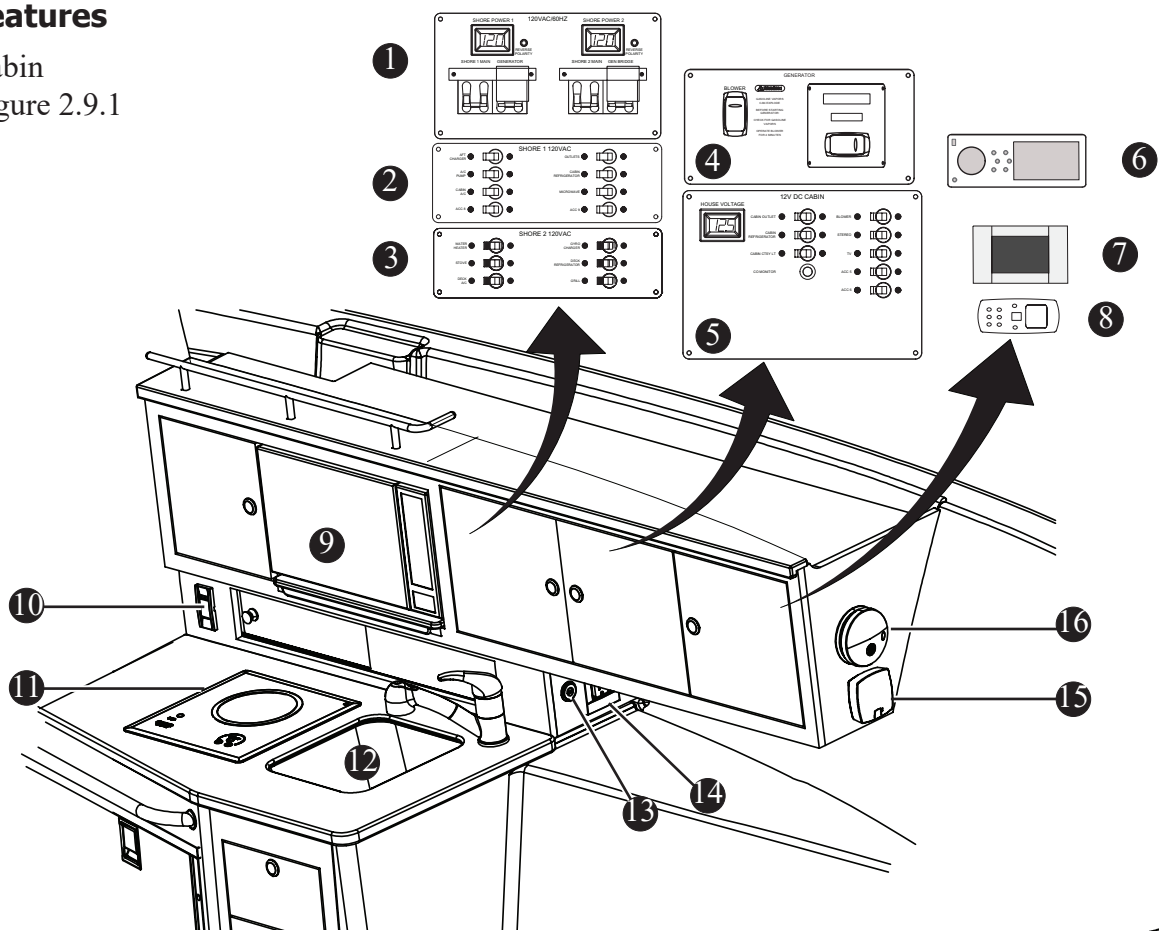

- 1 MAIN DISTRIBUTION PANEL - AC
- 2 SHORE POWER 1 PANEL
- 3 SHORE POWER 2 PANEL (OPTION)
- 4 GENERATOR PANEL (OPTION)
- 5 MAIN DISTRIBUTION PANEL - DC
- 6 STEREO
- 7 CABIN AC CONTROL (OPTION)
- 8 VHF RADIO CHARGING BASE
- 9 MICROWAVE
- 10 CABIN LIGHT SWITCH
- 11 ELECTRIC STOVE (OPTION)
- 12 GALLEY SINK
- 13 USB OUTLET
- 14 110V OUTLET
- 15 CO DETECTOR
- 16 SMOKE DETECTOR

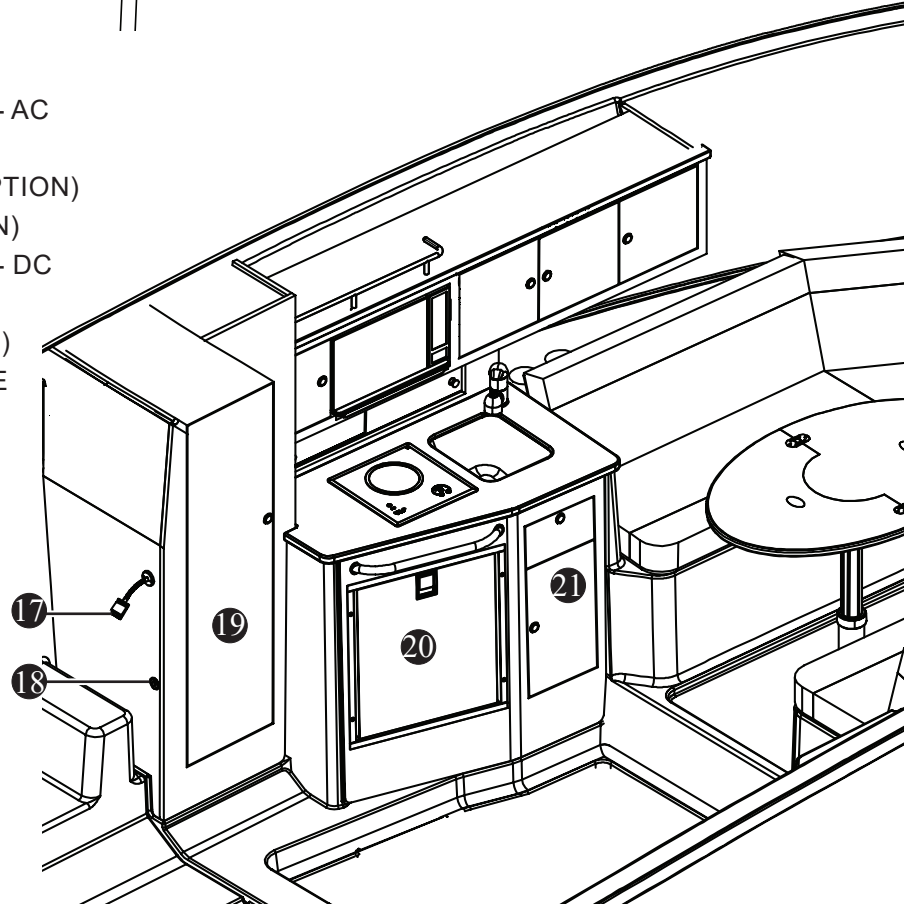

Cockpit Features

Figure 2.10.1

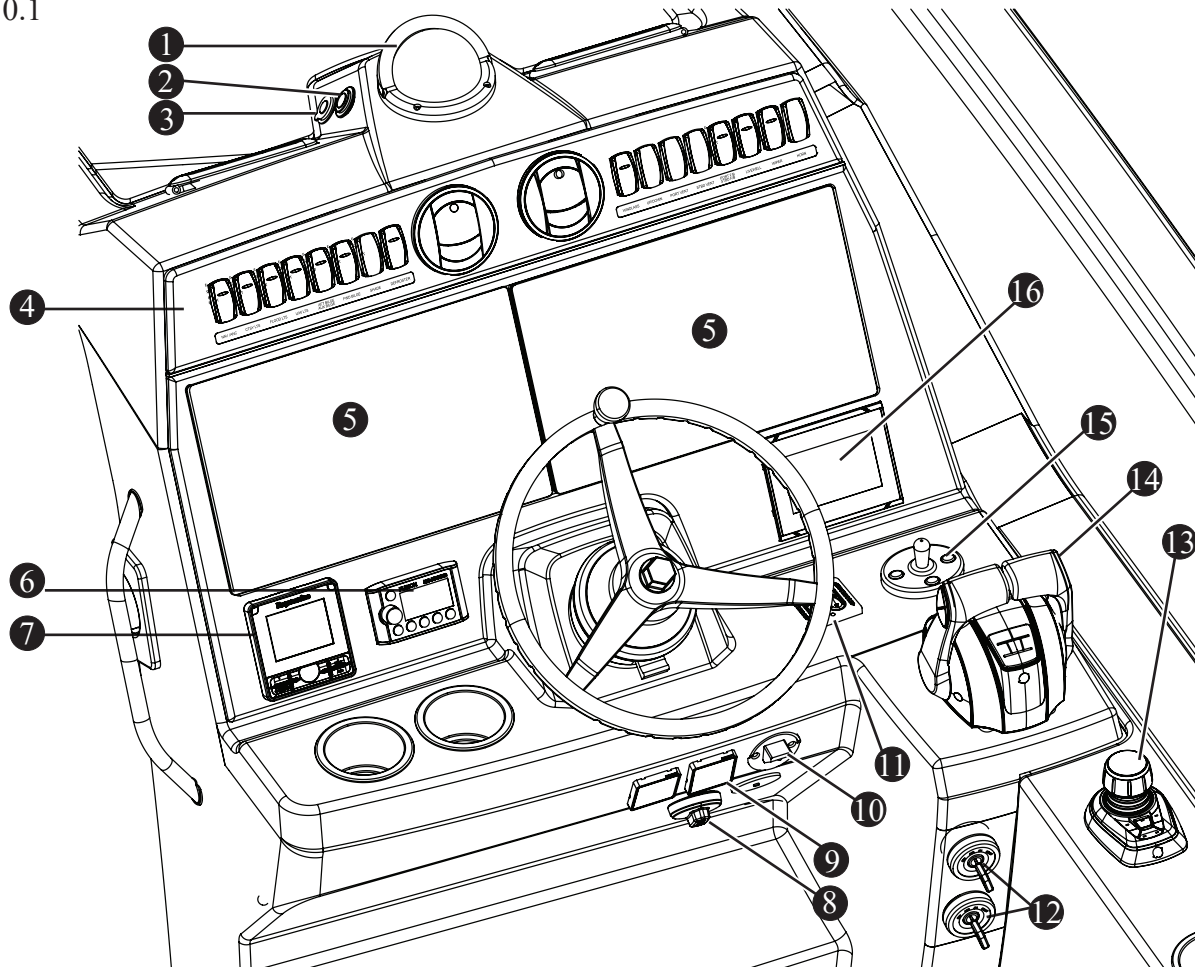

- ① COMPASS
- ② 12V OUTLET
- ③ USB OUTLET
- ④ HELM SWITCH PANEL
- ⑤ DUAL RAYMARINE (OPTION)
- ⑥ STEREO
- ⑦ AUTOPILOT (OPTION)
- ⑧ ENGINE DIAGNOSTIC PORT
- ⑨ RAYMARINE SD CARD PORT (OPTION)
- ⑩ EMERGENCY ENGINE CUT-OFF SWITCH
- ⑪ TRIM SWITCHES
- ⑫ IGNITION SWITCHES
- ⑬ JOYSTICK PILOTING (OPTION)
- ⑭ THROTTLE/GEAR CONTROL
- ⑮ SPOTLIGHT CONTROL (OPTION)
- ⑯ VESSELVIEW
- ⑰ 12V DC BREAKER PANEL
- ⑱ CONVERTIBLE SEATING

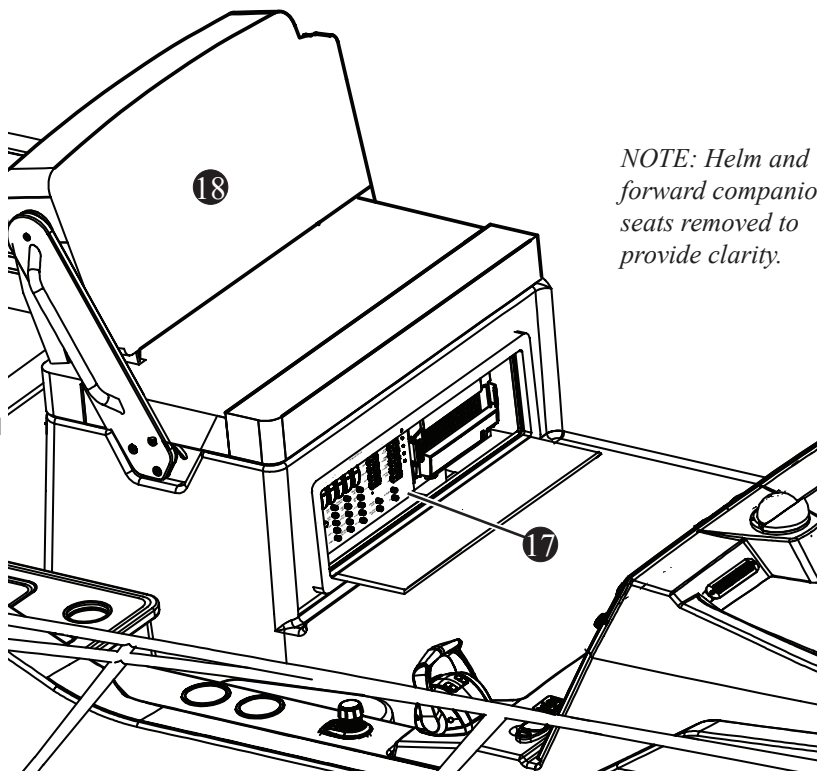

NOTE: Helm and forward companion seats removed to provide clarity.

Convertible Lounge Features
Figure 2.11.1

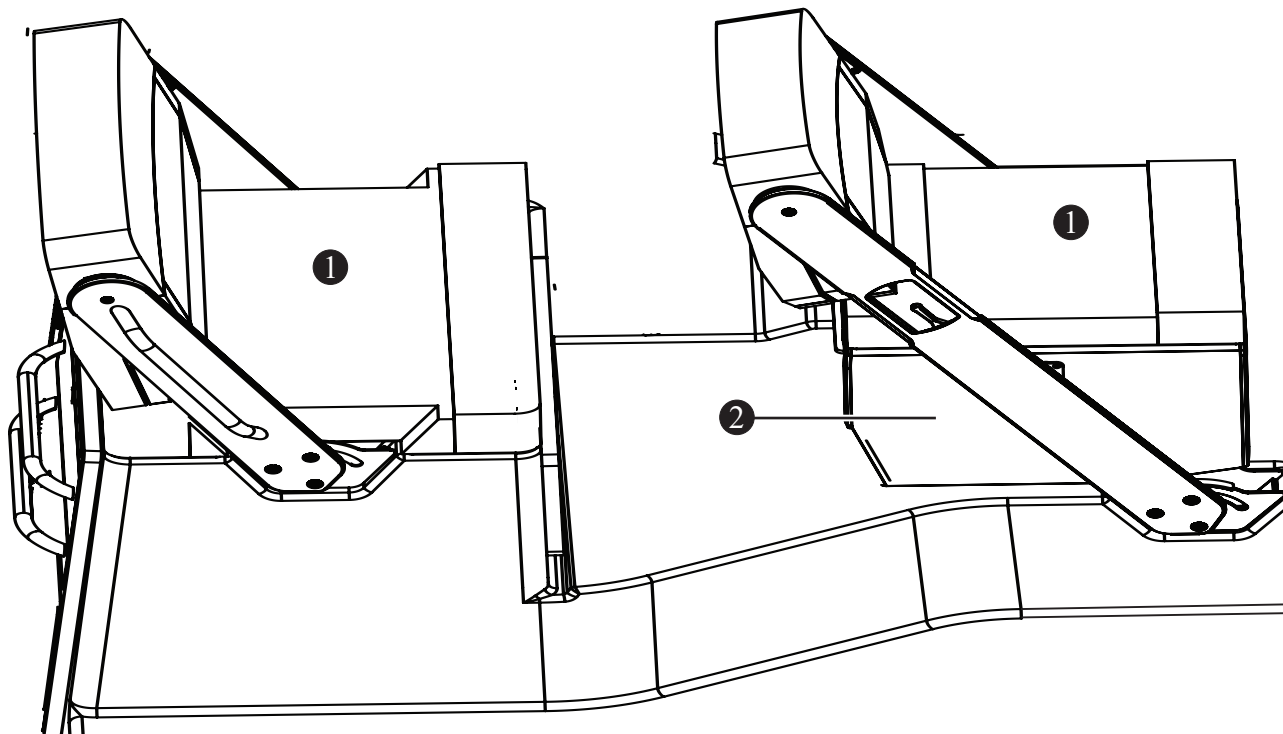

- ① CONVERTIBLE LOUNGE SEATS
- ② LOUNGE TABLE (HIDDEN)
- ③ CONVERTIBLE LOUNGE FOOTREST
- ④ STEP TO FOOTREST

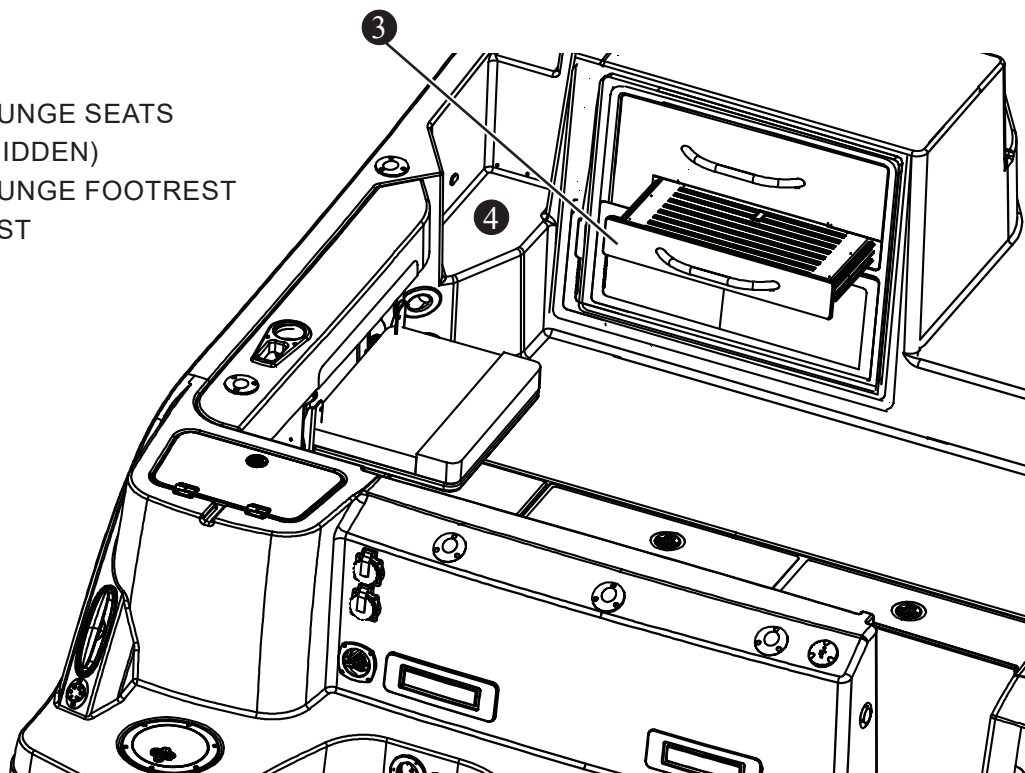

Cockpit/Transom Features
Figure 2.12.1

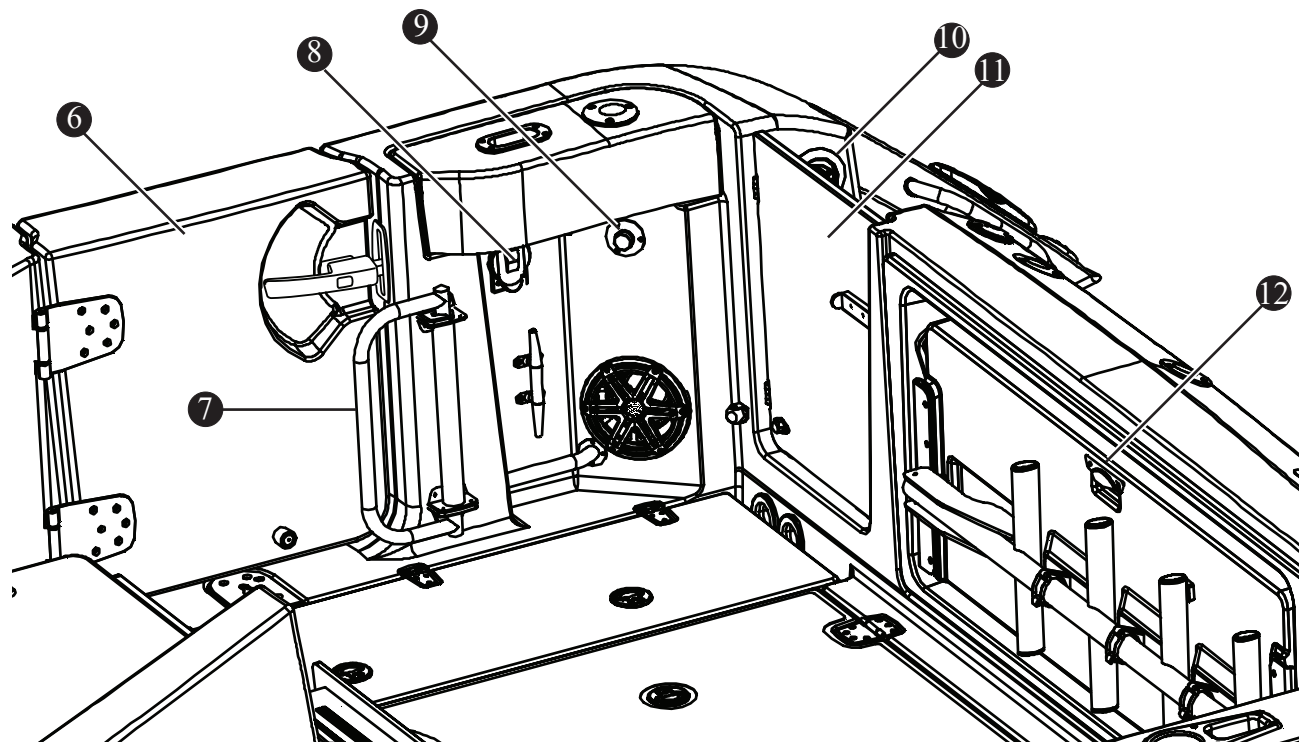
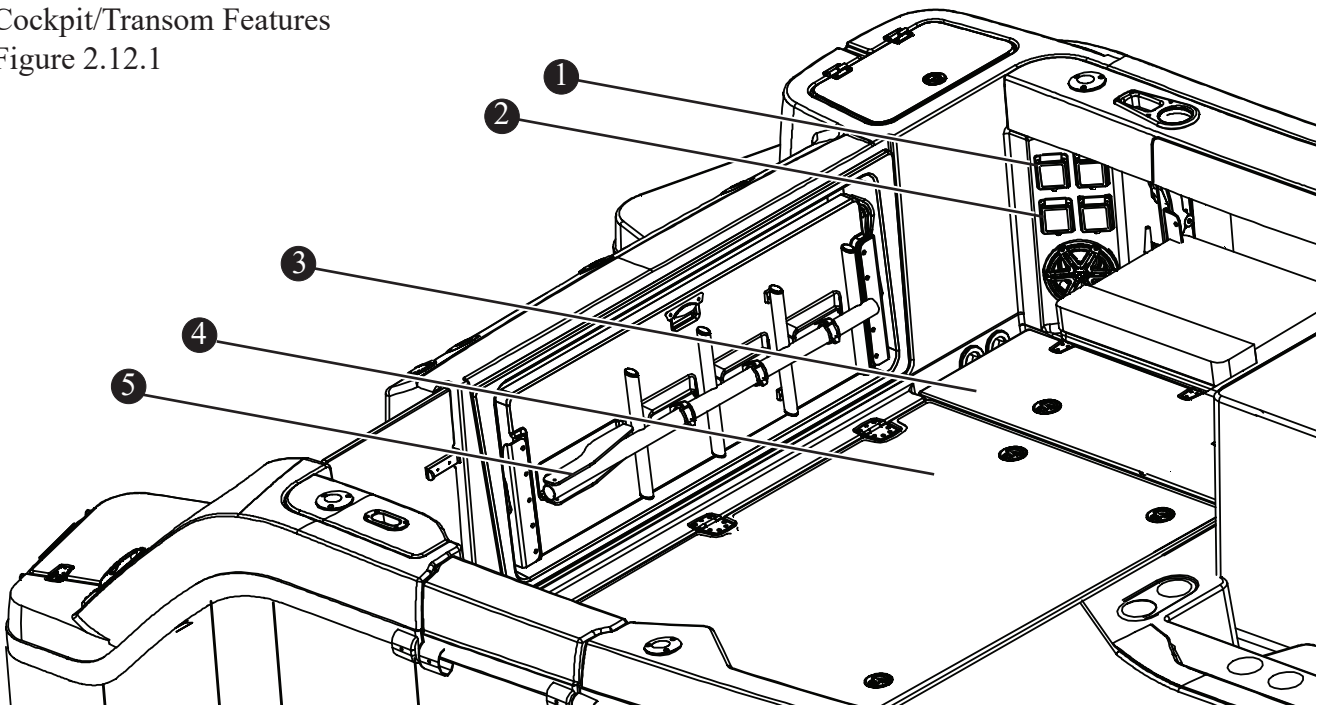

- | | |
|---|--------------------------|
| ① SHORE POWER BREAKER | ⑦ BOARDING HANDLE |
| ② EQUIPMENT LEAKAGE CIRCUIT INTERRUPTER | ⑧ DOWNRIGGER RECEPTACLE |
| ③ FISHBOX | ⑨ FRESH WATER CONNECT |
| ④ MECHANICAL ACCESS HATCH | ⑩ FRESH WATER SHOWER |
| ⑤ DIVE LADDER | ⑪ TRANSOM DOOR WITH LOCK |
| ⑥ DIVE DOOR WITH LOCK | ⑫ FOLD-DOWN BENCH HANDLE |

Cockpit/Transom Features (continued)

Figure 2.13.1

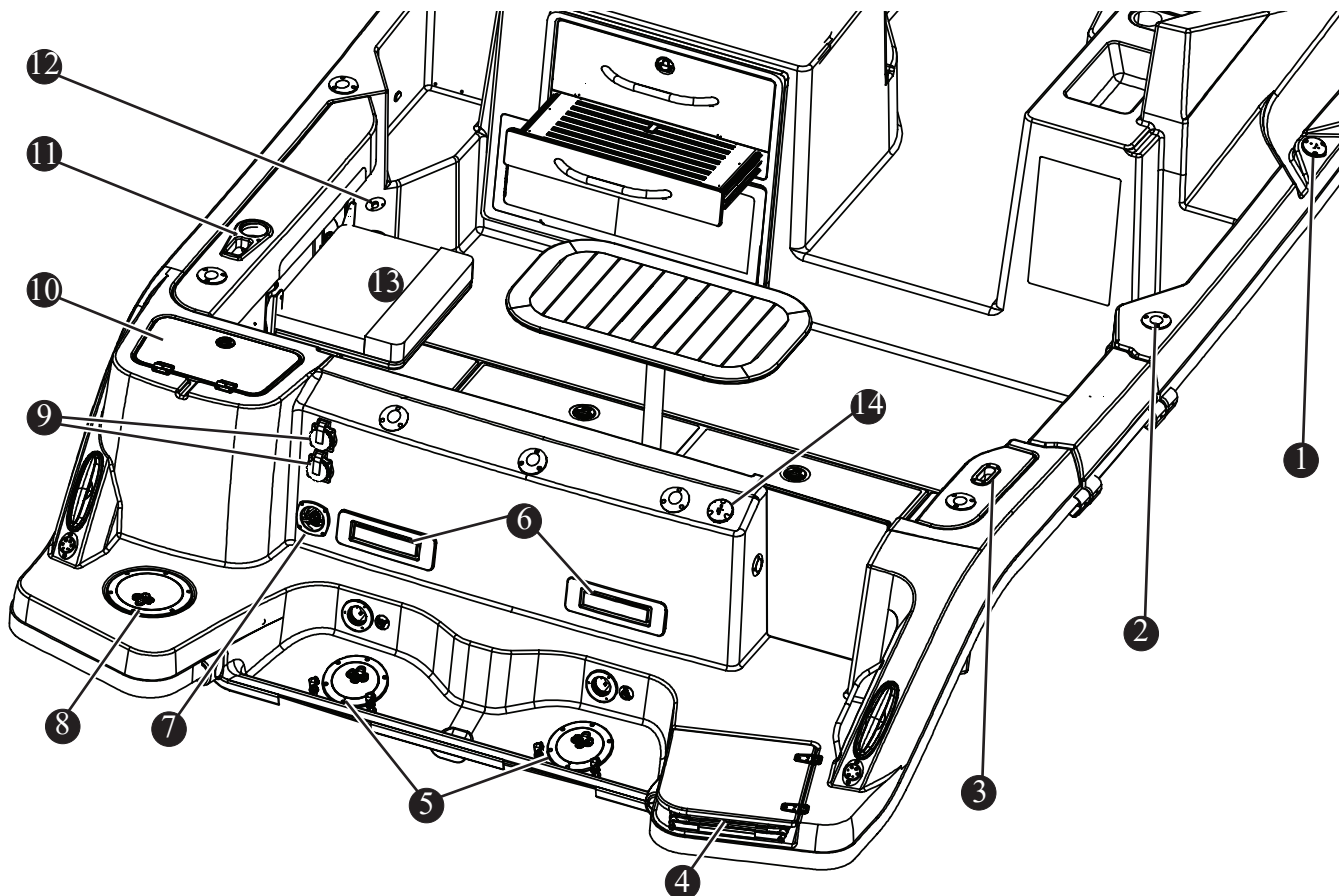

- | | |
|---------------------------------|----------------------------|
| ① FRESH WATER INLET (OPTION) | ⑧ TRIM TAB ACCESS PLATE |
| ② ROD HOLDERS (MULTIPLE) | ⑨ SHORE POWER INLET |
| ③ HAWSE PIPE | ⑩ LIVEWELL |
| ④ REBOARDING LADDER | ⑪ HAWSE PIPE W/ CUPHOLDER |
| ⑤ ACCESS PLATES | ⑫ RAW WATER CONNECTION |
| ⑥ BILGE VENT (GENERATOR OPTION) | ⑬ FOLD-DOWN BENCH (OPTION) |
| ⑦ FRESH WATER CONNECTION | ⑭ WASTE PUMPOUT |

Hardtop Features
Figure 2.14.1

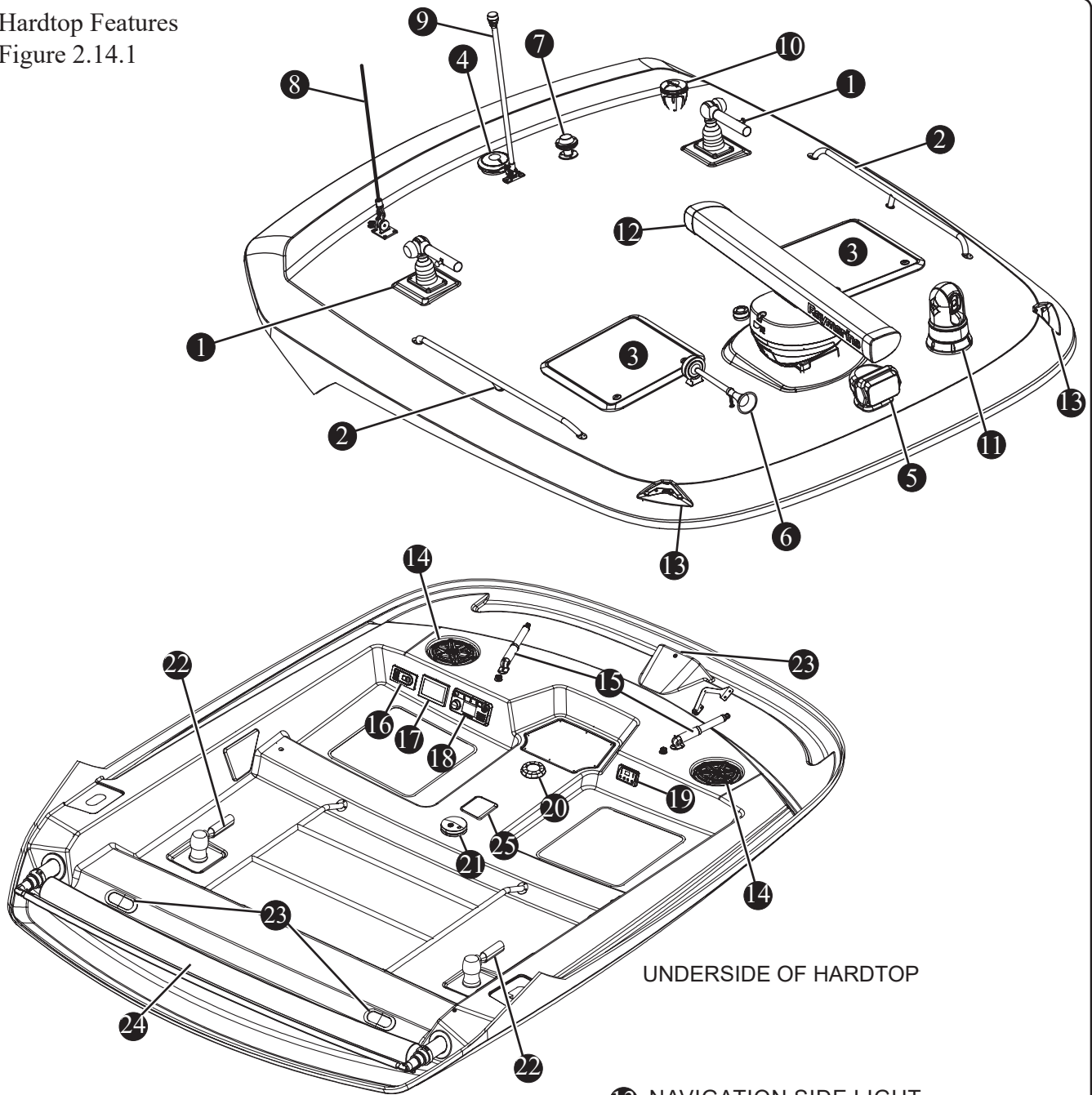

UNDERSIDE OF HARDTOP

- ① RADIAL OUTRIGGER (OPTION)
- ② GRAB RAIL
- ③ HARDTOP HATCH (OPTION)
- ④ MERCURY IMU (OPTION)
- ⑤ SPOTLIGHT (OPTION)
- ⑥ HORN
- ⑦ SATELLITE ANTENNA (OPTION)
- ⑧ VHF ANTENNA (OPTION)
- ⑨ ALL ROUND (ANCHOR) LIGHT
- ⑩ GPS ANTENNA (OPTION)
- ⑪ INFRARED CAMERA (OPTION)
- ⑫ RADAR ARRAY (OPTION)

- ⑬ NAVIGATION SIDE LIGHT
- ⑭ STEREO SPEAKER
- ⑮ WINDSHIELD VENT ACTUATOR (2)
- ⑯ ACTIVE TRIM (OPTION)
- ⑰ GYRO DISPLAY (OPTION)
- ⑱ VHF DISPLAY (OPTION)
- ⑲ A/C OR HEATER CONTROL (OPTION)
- ⑳ DOME LIGHT
- ㉑ SMOKE DETECTOR
- ㉒ RADIAL OUTRIGGER HANDLE (OPTION)
- ㉓ FLOOD LIGHTS
- ㉔ ELECTRIC SUN SHADE
- ㉕ CARBON MONOXIDE DETECTOR

Notable Options

Figure 2.15.1

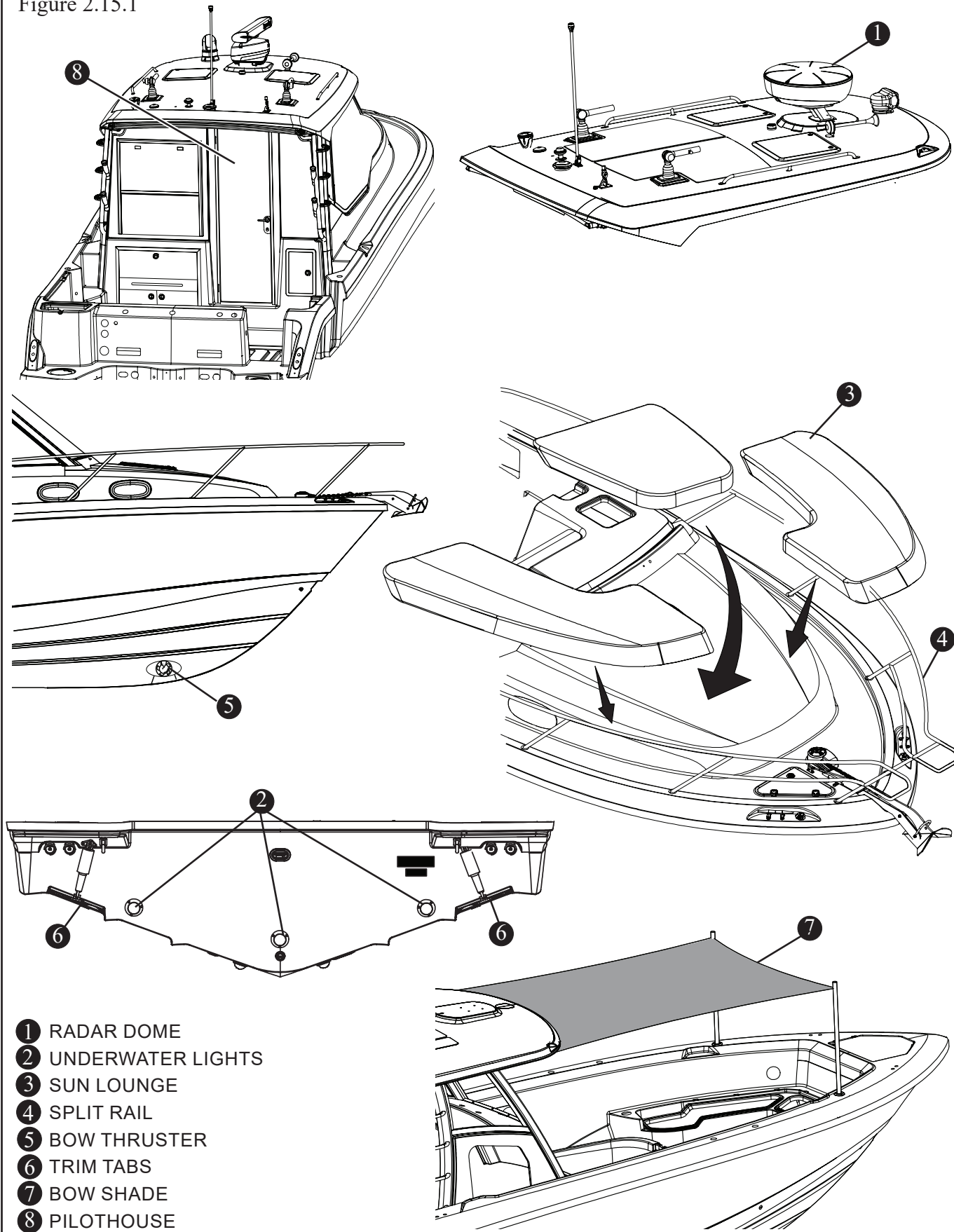

- ① RADAR DOME
- ② UNDERWATER LIGHTS
- ③ SUN LOUNGE
- ④ SPLIT RAIL
- ⑤ BOW THRUSTER
- ⑥ TRIM TABS
- ⑦ BOW SHADE
- ⑧ PILOTHOUSE

Storage

Figure 2.16.1

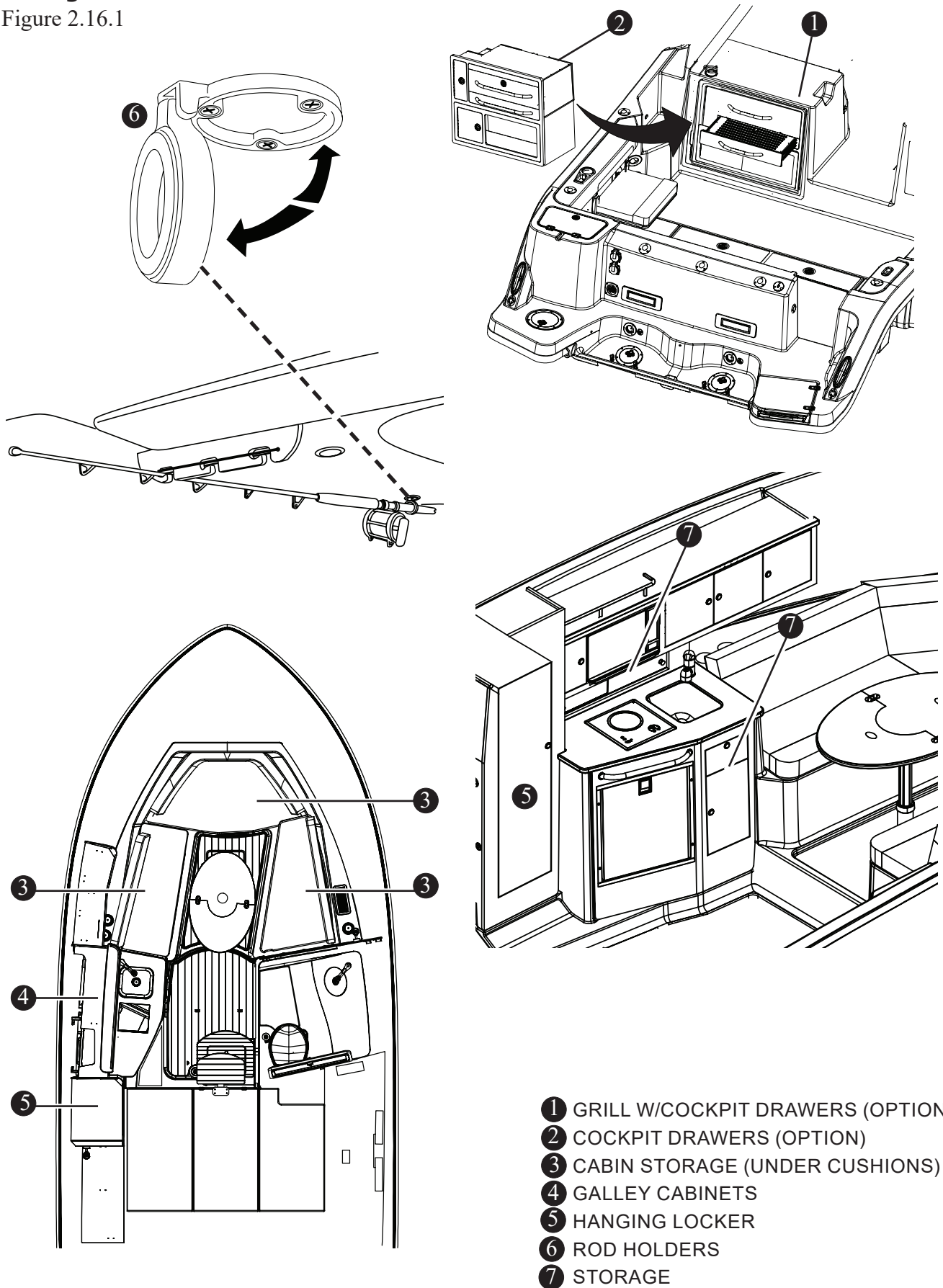

- ① GRILL W/COCKPIT DRAWERS (OPTION)
- ② COCKPIT DRAWERS (OPTION)
- ③ CABIN STORAGE (UNDER CUSHIONS)
- ④ GALLEY CABINETS
- ⑤ HANGING LOCKER
- ⑥ ROD HOLDERS
- ⑦ STORAGE

Canvas (Option)

The optional canvas set consists of side covers, a main cover, and a lounge cover. The canvas set will keep its appearance and maintain proper working order provided you follow a few simple steps for cleaning and maintenance (see chapter 5, *Canvas Care and Maintenance*).

Canvas Sections

Figure 2.17.1

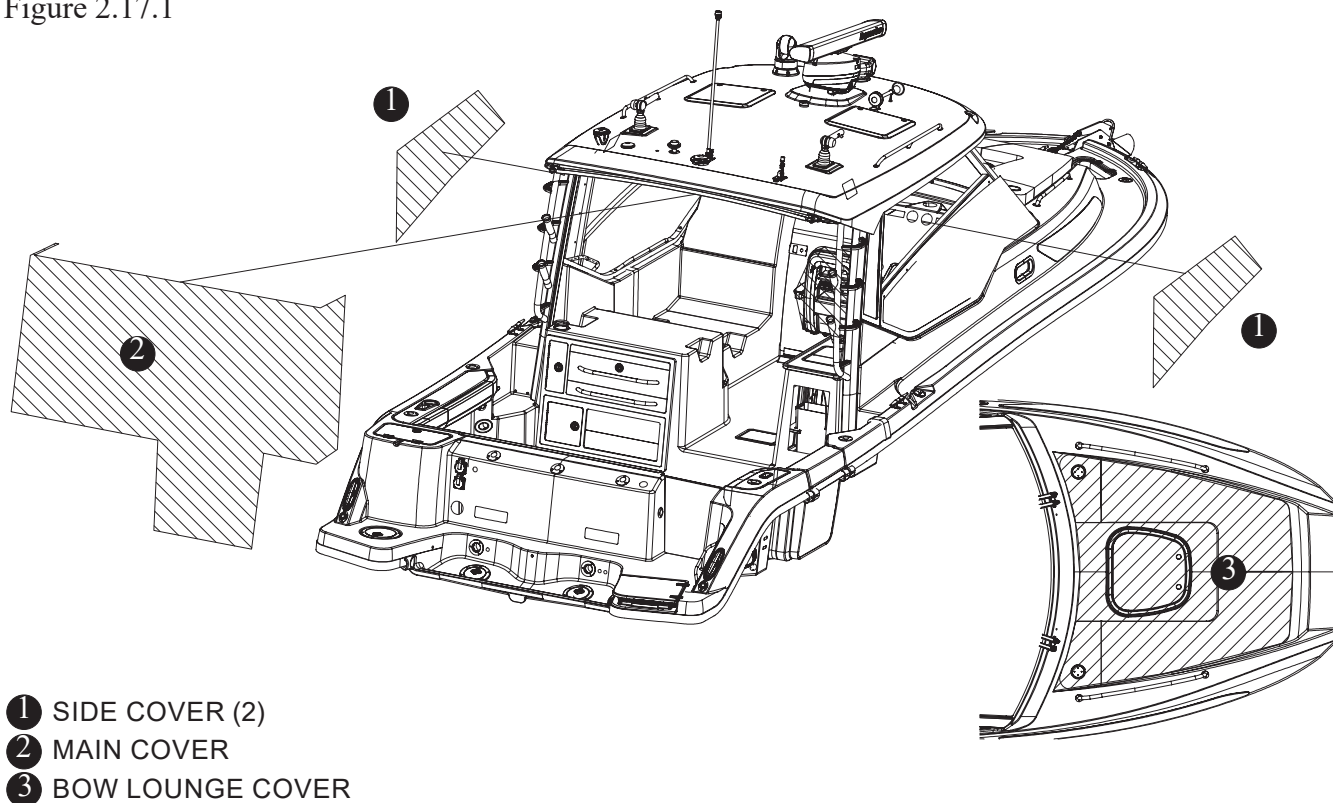

- ① SIDE COVER (2)
- ② MAIN COVER
- ③ BOW LOUNGE COVER

Helm Switch Panel

Figure 2.17.2

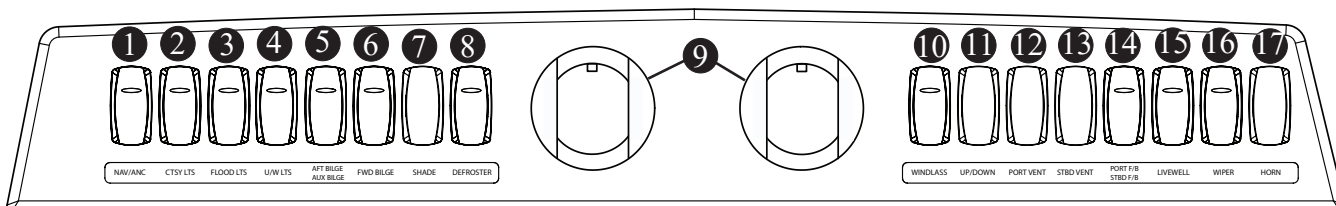

- | | | |
|----------------------------|----------------------|----------------------|
| ① NAVIGATION/ANCHOR LIGHTS | ⑦ SHADE | ⑬ STARBOARD VENT |
| ② COURTESY LIGHTS | ⑧ DEFROSTER | ⑭ PORT/STARBOARD F/B |
| ③ FLOOD LIGHTS | ⑨ A/C VENTS (OPTION) | ⑮ LIVWELL |
| ④ UNDERWATER LIGHTS | ⑩ WINDLASS ON/OFF | ⑯ WIPERS |
| ⑤ AFT/AUX BILGE | ⑪ WINDLASS UP/DOWN | ⑰ HORN |
| ⑥ FORWARD BILGE | ⑫ PORT VENT | |

SmartCraft™ VesselView

This vessel is equipped with the SmartCraft VesselView feature. VesselView allows the operator to receive critical operational information, displayed clearly and instantly at the helm display. The system continuously monitors and reports information ranging from basic operating data to detailed vessel environment information.

System Calibration (For First Time Use)

Boston Whaler or your dealer has calibrated the Smartcraft VesselView to the boat's equipment. If equipment is added, system must be recalibrated.

FOR RECALIBRATION OR MANUFACTURER INFORMATION REFER TO OWNER'S PACKET. FOR COMPLETE INSTRUCTIONS AND WARRANTY INFORMATION.

VesselView MOBILE

VesselView MOBILE connects the SmartCraft™ data network to your iPhone or android mobile device. With VesselView MOBILE you have the power of SmartCraft on your mobile device with all the digital data your SmartCraft engine supports plus new features such as:

- Maintenance reminders
- Mapping
- Performance summary
- Fault code diagnostics

Digital Throttle/Shift (DTS®)

CAUTION

Shift controls into neutral before starting engine. Shift only when engine is at idle. Reversing at high speeds can cause flooding/swamping due to water being pushed over the transom.

NOTICE

Wind and sea currents can change how this vessel responds while in motion. Understanding this vessel and its reactions at speed will make boating safer and more enjoyable.

This vessel is equipped with a state of the art drive-by-wire gear shift and throttle control system. The unit controls both the shifting mechanism and throttle

(see Figure 2.18.1). The throttle control regulates the RPM of the engine. Regulating the RPM of the engine will control the speed of the boat. Moving the lever forward engages the forward gear. Continuing to move the lever forward will increase the forward speed of the boat.

Likewise, to reverse power, bring the control lever back to engage the reverse gear and increase the reverse thrust by continuing to pull back on the throttle control. The control must be in the neutral position to start your engine. Neutral is the most central position of the control unit and acts as an idle (you will hear and feel a click when neutral is engaged). While in this position, the propeller is not rotating. There is a *THROTTLE ONLY* button on the throttle control that when depressed will disengage the shifting mechanism and will allow you to operate the throttle without engaging the propeller. The button will automatically engage the shifting mechanism once the throttle control has been moved back to its center position.

Throttle Only/Trim Switches

Figure 2.18.1

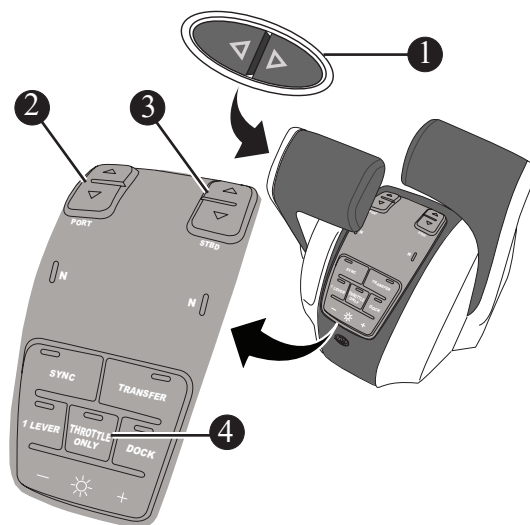

- ① ALL ENGINES TRIM SWITCH
- ② PORT ENGINE TRIM SWITCH
- ③ STARBOARD ENGINE TRIM SWITCH
- ④ THROTTLE ONLY

Power Trim

The power trim and tilt system located on the shift control lever (see Figure 2.18.1) allows you to raise and lower the engine for optimum performance and is used for trailering, launching, and beaching.

Operation

The engine trim is controlled by a momentary rocker switch, where constant pressure must be applied to the switch during the raising and lowering cycles. Use the power trim switch to obtain ideal boat angle (in relation to the water surface) for a given load and water condition. In most cases the best all-around performance is obtained when the boat runs at an angle between a 3 to 5 degrees.

ATTENTION

Ensure continuous visibility of other boats, swimmers and obstacles during bow-up transition to planing. Adjust engine to an intermediate trim as soon as boat is on plane.

REFER TO THE ENGINE MANUFACTURER'S MANUAL IN OWNER'S PACKET FOR COMPLETE INSTRUCTIONS AND WARRANTY INFORMATION.

Active Trim (Option)

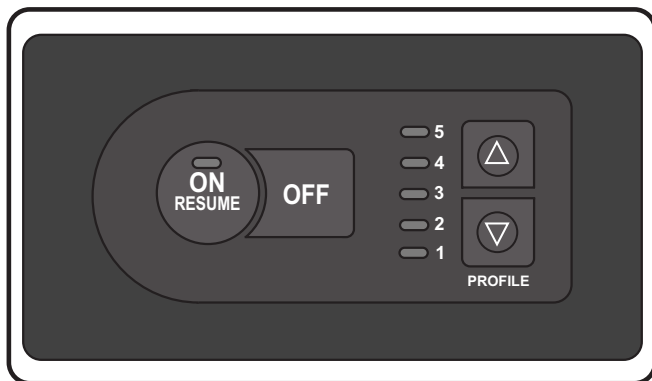

If equipped, the active trim panel is located on the forward hardtop above the console.

Active trim provides the benefit of perfect trimming without constantly monitoring and adjusting trim with changes to boat speed or when going into turns.

Active trim controls the trim in accordance with boat speed and engine RPM. This avoids potential problems such as engines trimming up (instead of down) if the propeller breaks loose in a hard turn. It also avoids issues with the engine trimming up too early or too late when the boat is getting on plane.

Active trim has five selectable trim profiles that accommodate nearly any boat application. These profiles allow operators to compensate for changes in boat load, operator preference and weather conditions, while maintaining full auto operation.

REFER TO OWNER'S PACKET FOR COMPLETE INSTRUCTIONS AND WARRANTY INFORMATION.

Navigation Lighting

This vessel comes equipped with navigation lighting for your safety. Regulations state that all boats must display navigation lights between sunset and sunrise and during periods of restricted visibility, such as rain, fog, haze, etc. If operating in reduced visibility or between sunset and sunrise it is necessary to maintain a safe speed and post a lookout.

It is the operator's responsibility to ensure that the navigation lights are in good working order and that the proper lighting is shown and not obstructed in its intended arc of visibility. This vessel's navigation lights may include an expiration date on the housing. If one is located, replace light before expiration date, even if light is functional, as lighting quality may be compromised.

Do not add lights that interfere with required navigation lights. Some lights, such as blue colored lights, may be illegal to display on a boat. It is the owner's responsibility to ensure that displayed lights are also compliant with local regulations.

ATTENTION

The improper sequence of navigation lighting may be as dangerous as no lighting at all.

Operating the Navigation Lighting

A three-position switch, located on the console switch panel marked *NAV/ANC* controls the navigation and anchor lighting (see Figure 2.20.1).

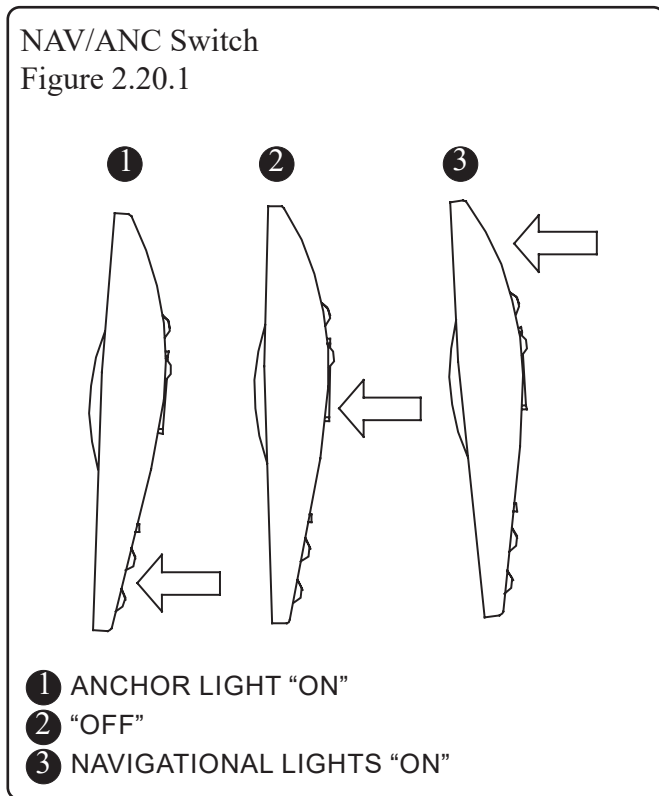

Navigation/Anchor Lighting

Figure 2.20.2

112.5° PORT
NAVIGATION
SIDE LIGHT (RED)
VISIBLE 1 NM

112.5° STARBOARD
NAVIGATION
SIDE LIGHT (GREEN)
VISIBLE 1 NM

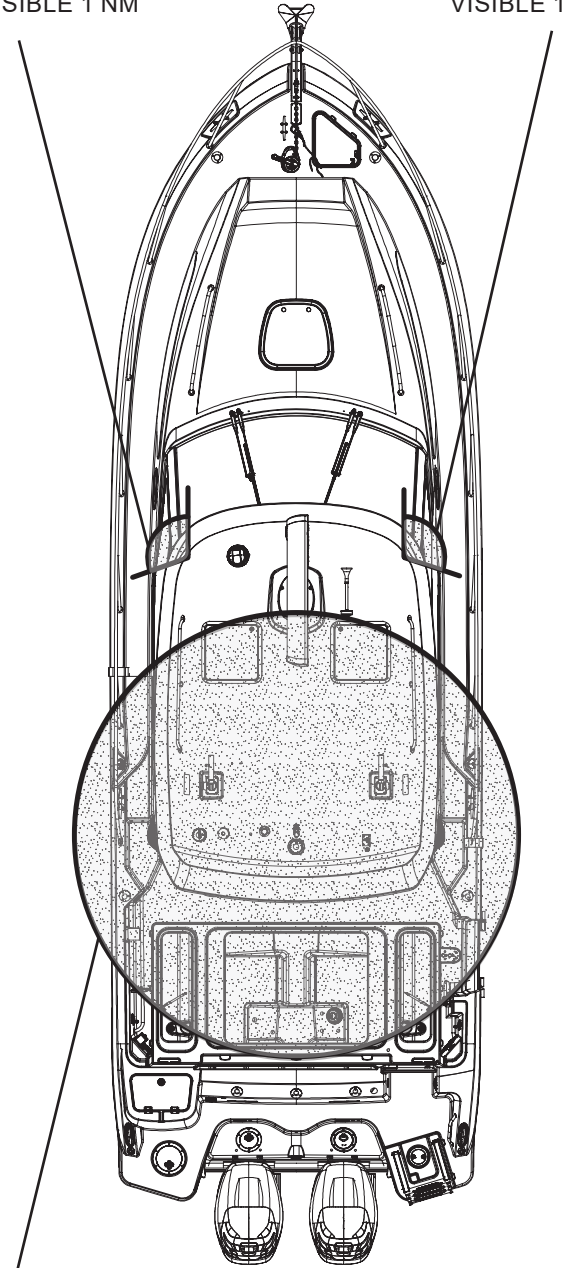

360° ALL-AROUND LIGHT (WHITE) VISIBLE 2 NM

! CAUTION

Do not use accent lights when navigational lights are in use as this may interfere with the effectiveness of the navigational lights.

In the navigation lights *ON* position the port (red), starboard (green) and all-around (white) lights will illuminate. These lights let other vessels know the approximate size and direction of travel of this vessel, depending on which lights they can see. In the anchor lights *ON* position, the white, 360 degrees, all-around light will illuminate, showing other boaters your location while at anchor.

Trim Tabs

Your vessel may be equipped with electrically powered trim tabs (see Figure 2.21.1). If installed, the trim tabs are located on the bottom of the hull at the transom and are used to assist in leveling your vessel caused by uneven weight distribution or strong cross winds. The use of trim tabs may also increase your operator visibility, particularly during initial acceleration.

An untrimmed boat will:

- Reduce fuel economy
- Increase wear on your engine

ATTENTION

Visibility from the helm station may be limited, use of trim tabs may be necessary to maintain adequate visibility in some running conditions. Avoid serious injury or death from collisions. Maintain a lookout as required by USCG Navigation Rules.

Operation

The trim tabs are controlled by rocker switches located on the center part of helm console. Short momentary bursts of the rockers will achieve proper attitude of the hull. The trim tab switch is marked *bow up* and *bow down*. Using the trim tabs will:

- Level the boat; fore and aft, port and starboard.
- Reduce resistance in the steering system.
- Increase speed.
- Reduce strain on the engines.
- Provide a smoother, more stable ride.

Maintenance

The trim tabs are a completely sealed unit, waterproof and maintenance free. Aside from a general cleaning when the boat is out of the water you should also inspect the planes and hinges for marine growth and remove as necessary.

Electrically Powered Trim Tabs

Figure 2.21.1

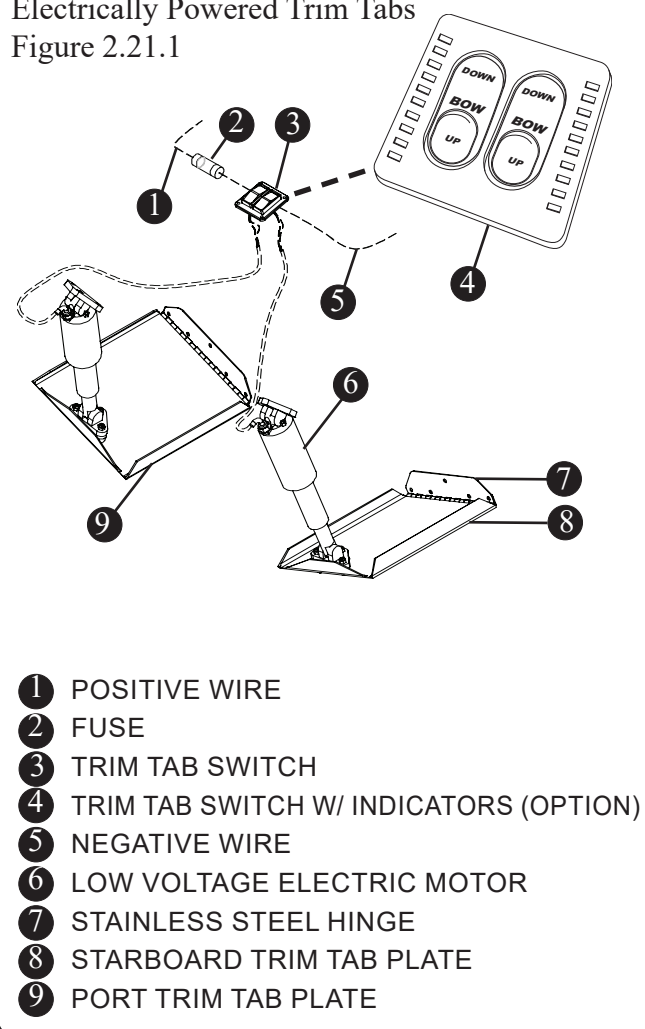

REFER TO OWNER'S PACKET FOR COMPLETE INSTRUCTIONS AND WARRANTY INFORMATION.

Joystick Piloting (Option)

Joystick technology is the latest enhancement in vessel control, providing effortless maneuverability. The joystick piloting system replaces the traditional bow thruster set up. Joystick piloting takes the stress out of docking, maneuvering in tight spaces and operating in less-than-ideal environments by providing the vessel operator 360-degree movement at their fingertips.

The system allows the operator to effortlessly move a multi-engine boat in any direction - including sideways, diagonally or spinning on its own axis - with a simple push or twist of a joystick. The operator controls the throttle, shifting and steering with one hand, with the joystick working in conjunction with the independently steered engines to move the boat in the desired direction. If equipped, the joystick is located in the cockpit (see Figure 2.22.1).

Joystick Piloting (Option)
Figure 2.22.1

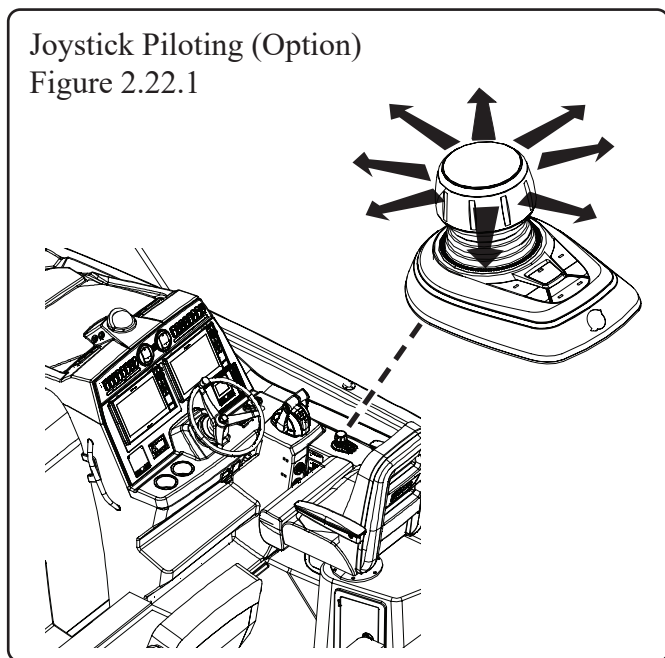

REFER TO OWNER'S PACKET FOR COMPLETE INSTRUCTIONS AND WARRANTY INFORMATION.

Digital Throttle and Shift

Digital Throttle and Shift (DTS) replaces the lag and hesitation of traditional throttle and shift cables with digital precision, resulting in smooth shifting and instant throttle response.

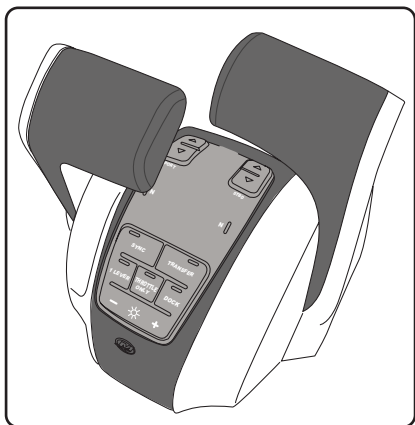

DTS includes many advanced features to improve the boating experience. Auto sync synchronizes multiple engine RPMs automatically and single lever mode allows control of multiple engines with one control lever.

VesselView®

VesselView provides up-to-date information for more than 30 engine parameters, including fuel level and range, oil temperature and pressure, water depth and more. It also provides advanced features such as Smart Tow®, ECO-Screen, Troll Control, and Cruise Control.

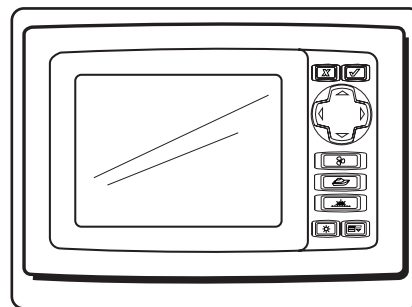

Skyhook® (digital anchor)

With the push of a button, Skyhook pinpoints the boat's position using a GPS satellite antenna and the engines and drives move independently to maintain the position and heading. It's ideal for holding a boat over a fishing spot, waiting for a drawbridge to open or maintaining position while waiting to refuel at a marina.

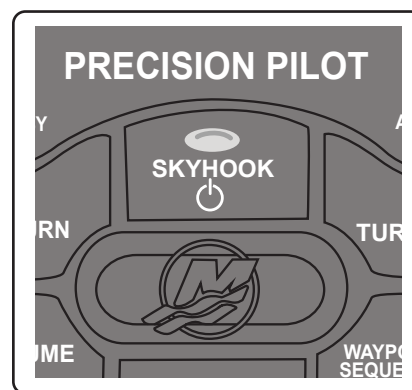

Integrated Autopilot

Auto heading and waypoint sequencing make navigating to a destination simple and efficient. A built-in digital compass set on auto heading maintains course and makes precise corrections with the touch of a finger. One-degree heading adjustments can be made with a tap on the joystick. Trips with multiple stops between the starting point and final destination are possible with waypoint sequencing, which allows the operator to plot the boat's course using multiple points.

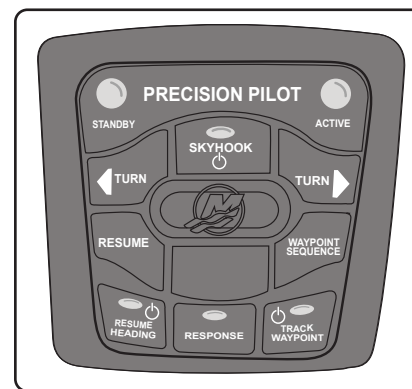

Electric Sun Shade (Option)

If equipped, the electrically actuated cockpit sun shade can be deployed or retracted by depressing the *Shade* switch located on the helm switch panel (see Figure 2.23.1). The sun shade is protected by a breaker located on the DC breaker panel.

Follow the canvas care instructions in chapter 5, *Care and Maintenance*.

! WARNING

Electric sun shade is intended for use while boat is anchored or moored and not while underway. Damage to boat or personal injury could occur if shade is used while underway.

NOTICE

A reset functionality has been incorporated into the sun shade controller to enable a service technician to quickly reset the shade position. In the event the shade does not operate at either the fully extended or fully retracted position, contact a Boston Whaler dealer for details.

Electric Sun Shade
Figure 2.23.1

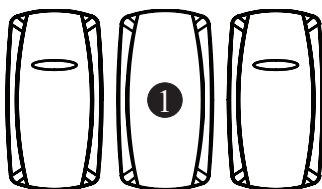

FWD BILGE SHADE DEFROSTER

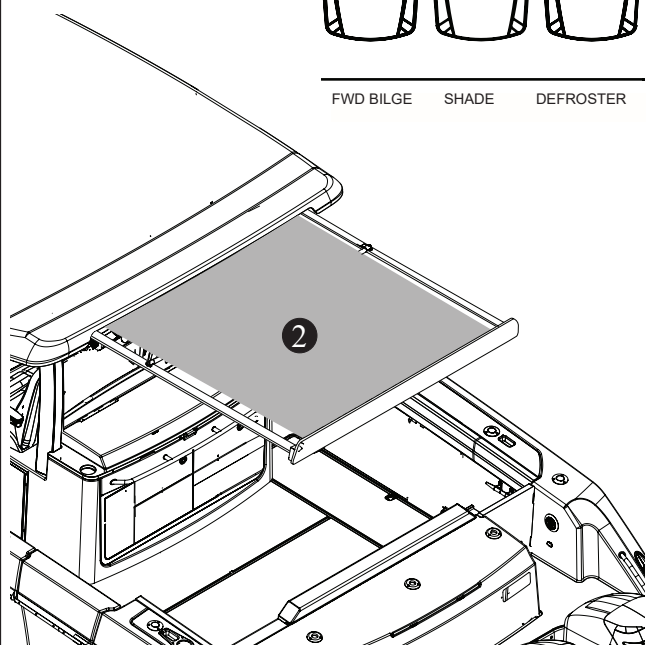

- ① SUN SHADE SWITCH (AT HELM)
- ② ELECTRIC SUN SHADE

Bow Shade (Option)

If equipped, the manually set up bow shade is constructed from four poles assembled into two poles as shown in Figure 2.23.2. Follow the canvas care instructions in chapter 5, *Care and Maintenance*.

! WARNING

Bow shade is intended for use while boat is anchored or moored and not while underway. Obstruction of navigation sidelights, damage to boat or personal injury could occur if shade is used while underway.

Bow Shade
Figure 2.23.2

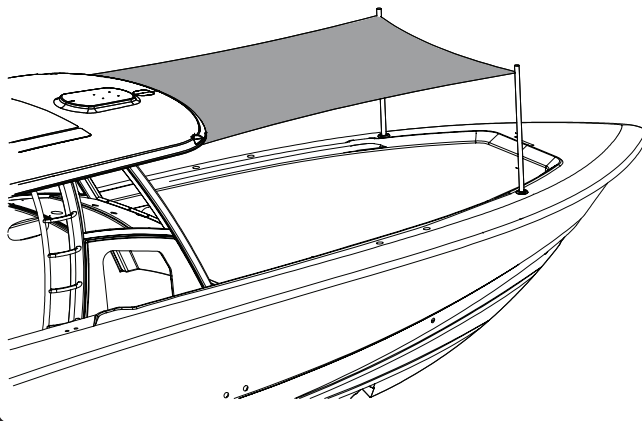

Electric Windshield Vent

The windshield vents, located at the top of the windshield, are electrically actuated. Switches labeled *PORT VENT* and *STBD VENT* are located on the helm switch panel and there is a reset breaker, labeled likewise, located on the main DC distribution panel behind the access door below the companion aft seat.

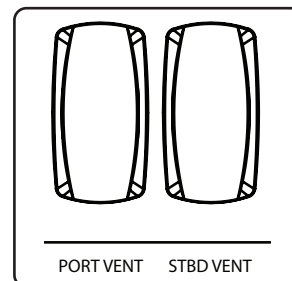

PORT VENT STBD VENT

Depress the top of a switch to open the vent. To close the vent depress the bottom of the switch. The *PORT VENT* and *STBD VENT* switches are momentary switches, which means they must be depressed and held in position until the vent is opened or closed completely.

Entertainment System

Stereo with Remote

The entertainment system on this vessel consists of a Fusion AM/FM stereo with CD player and remote control. The stereo unit is located on the face of the forward upper cabinet of the galley. The stereo remote control is located at the helm.

TV /DVD System (Option)

If equipped, the flat screen TV monitor is located in the cabin. The connection for dockside cable reception is located under the starboard gunwale in the cockpit. The combo CD/DVD player is located in a forward cabin cabinet.

Electric Stove (Option)

The optional electric stove is a single burner unit with touch controls. A series of lights indicate burner operation and hot surfaces. When lit, the *HOT* indicator light indicates that some portion of the surface is to warm to touch. Before first time use, clean the cooktop with cook top cleaner. This provides a clean, shiny surface on the cooktop. Regular cleaning keeps your cooktop free from scratches and stains.

Cook Top Retaining Pins

The cooktop features a unique system which provides a barrier around the cooking surface to keep cookware from sliding off the surface and onto the counter or floor of the cabin. The pop-up pins on the cooktop are seated flush with the cooktop surface when not in use. Cook pan retaining pin use:

To use, push and release each of four pop-up pins. When finished, press pins back down (see Figure 2.24.1).

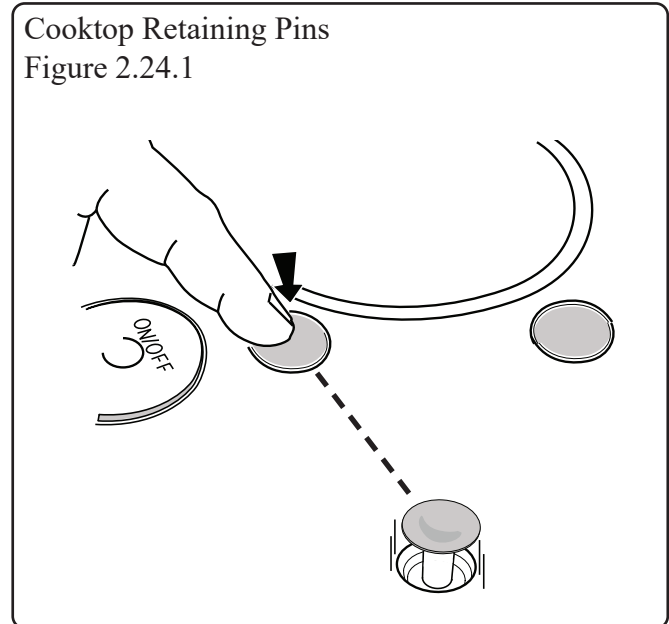

REFER TO OWNER'S PACKET FOR COMPLETE INSTRUCTIONS AND WARRANTY INFORMATION.

Galley Refrigerator/Freezer (option)

The AC/DC refrigerator/freezer is located on the front of the galley. The refrigerator is powered by shore power, if connected, or by the generator (option). The *REFRIG* breaker on the 120V AC breaker panel on the main distribution panel located in the port cabin must be on for the refrigerator/freezer to function when using shore power or generator is not in use. If not connected to shore power or the optional generator, the refrigerator/freezer is powered by the house batteries.

REFER TO OWNER'S PACKET FOR COMPLETE INSTRUCTIONS AND WARRANTY INFORMATION.

NOTICE

To avoid draining the batteries, the refrigerator and/or battery switch must be turned off.

Cockpit Table (Option)

The optional cockpit table is stored on the underside of the mechanical access hatch. Open the hatch and, while holding the table in place, swing the retaining hinges out of the way to remove the table. Remove the support post and place it into the cockpit floor receptacle; place the table on top. Secure the table with the tightening handle. When not in use or while underway, stow the table and post back in the stored position.

Cockpit Table Assembly

Figure 2.25.1

- ① MECHANICAL ACCESS HATCH
- ② COCKPIT TABLE
- ③ SUPPORT POST
- ④ RETAINING HINGES (2)

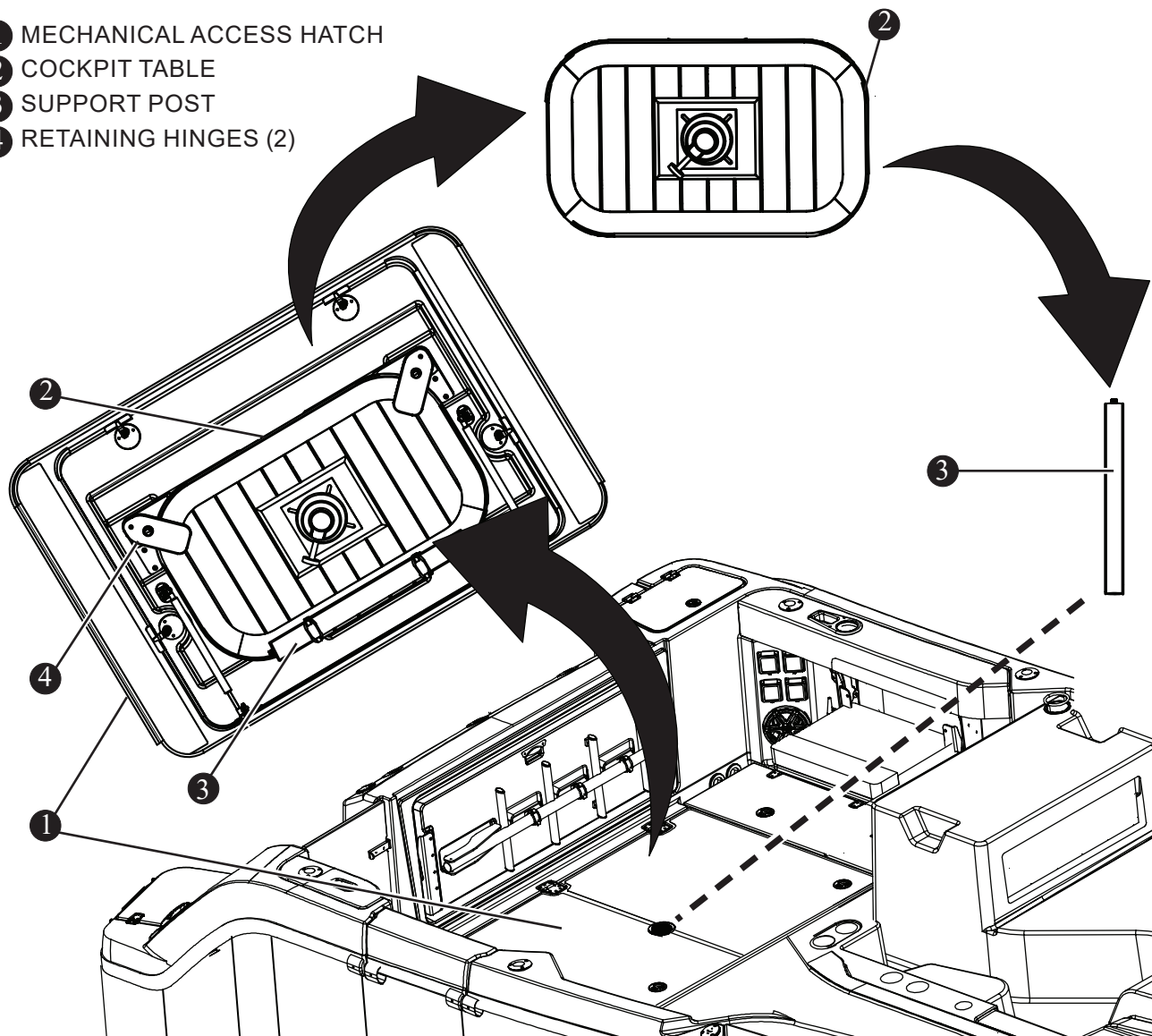

V-Berth

The cabin can be converted into sleeping quarters to accommodate two people comfortably in the forward section of the cabin. Ensure that the table is in the open position. Then push down in the center of the table pedestal, which is gas actuated, to lower it (see Figure 2.26.1). Pull the side seat cushions to the middle using the dinette table for support (see Figure 2.26.2). Complete the berth by using the back cushions to fill the remaining space.

(Figure 2.26.1)

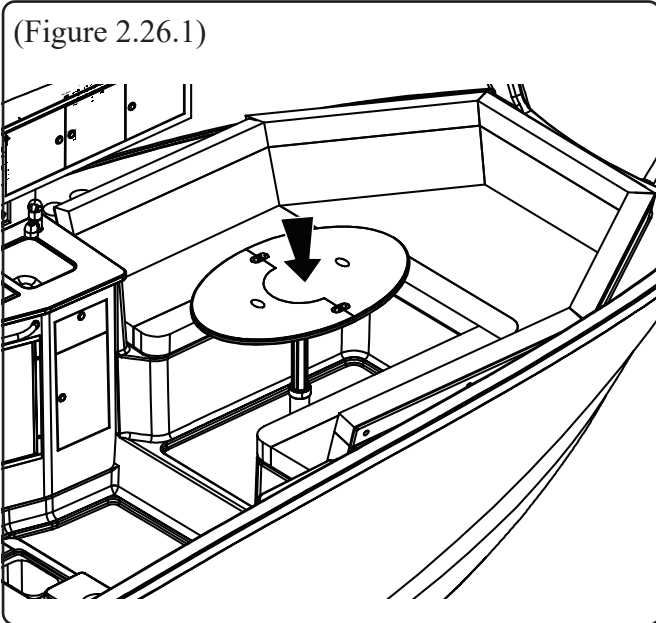

(Figure 2.26.2)

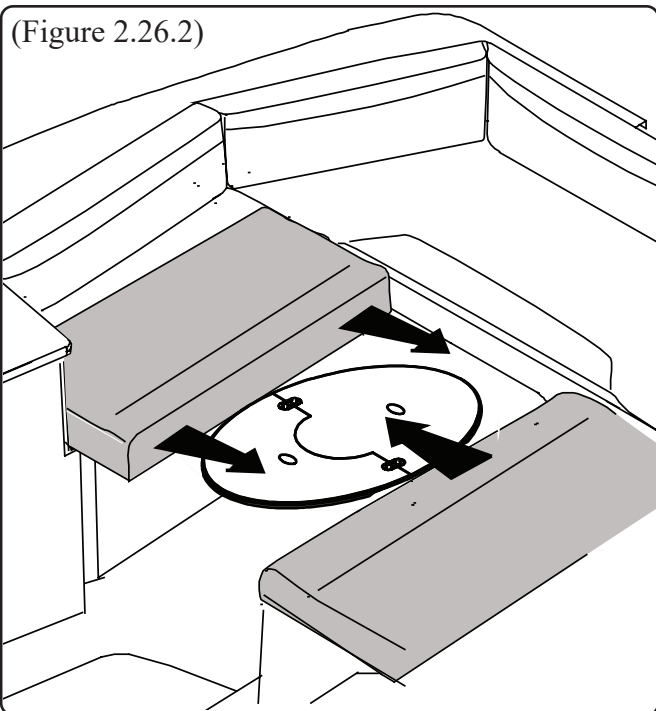

Radial Outriggers (Option)

If equipped, there are two radial outriggers. One each located on the port and starboard side of the hardtop. The outriggers are adjustable to provide ease of operation and storage.

Extending Outriggers

Starting with the outboard section, extend each section out until the locking button snaps into place.

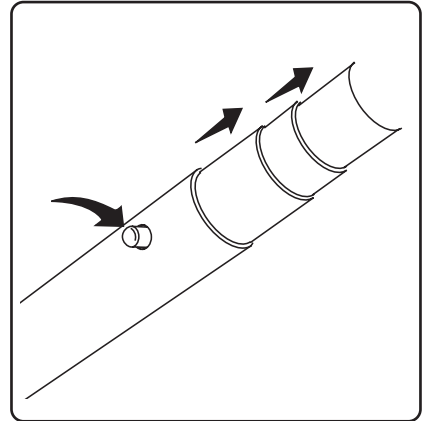

Retrieving Outriggers

Starting with the inboard most section, Push in the locking button on each succeeding section and insert sections into the shaft until all are completely seated in the stowed position.

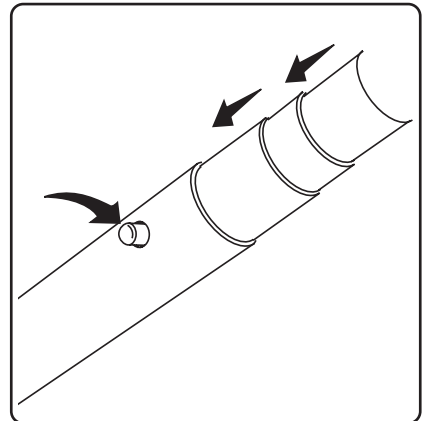

Radial Outriggers (Option)

Figure 2.27.1

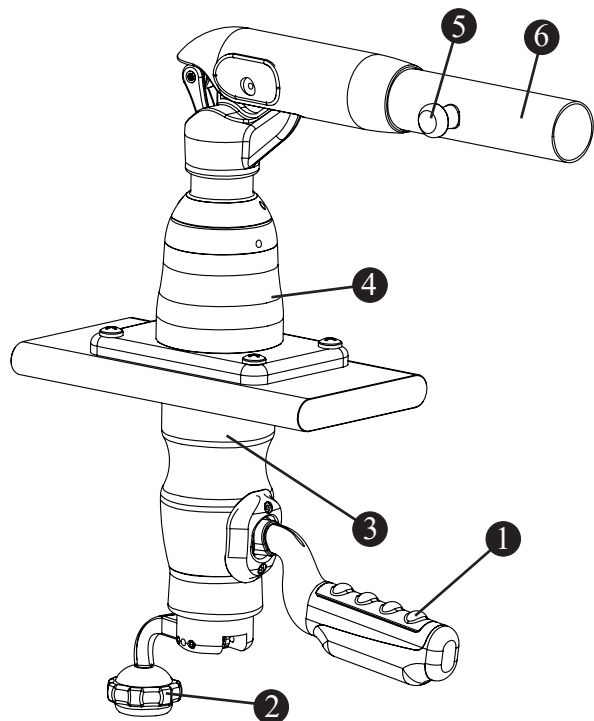

- ① ROTATION ADJUSTMENT HANDLE
- ② POWER CRANK HANDLE
- ③ LOWER UNIT
- ④ UPPER UNIT
- ⑤ SHAFT LOCK
- ⑥ EXTENDABLE SHAFT

Positioning Outriggers

Raising or lowering

Extend the power crank handle out and lock into place. To raise, turn handle clockwise. To lower, turn handle counterclockwise.

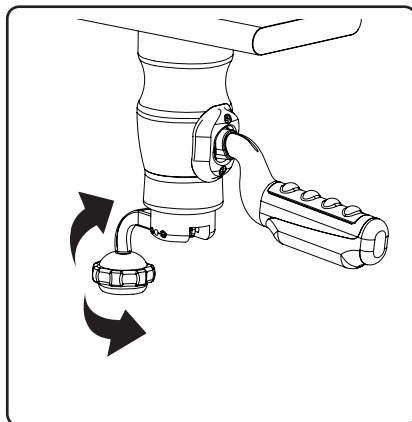

Rotating

Pull down on the lower unit handle and rotate to the desired position. When released the handle will hold the outrigger shaft into position.

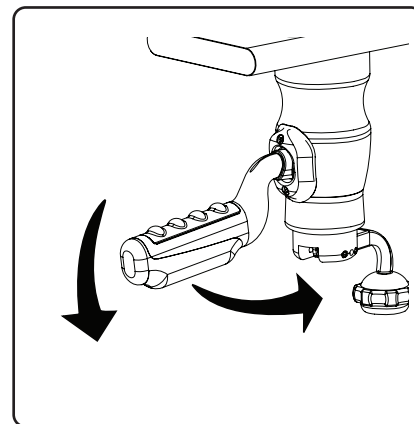

Maintenance

When at port, extend the outriggers and clean with a mild, non-abrasive soap and fresh water, wipe with a dry cloth and allow to air dry. When dry collapse the outriggers to the stowed position. Periodically lightly lubricate the cam and the shaft of the cam knob.

Transom Door

The transom door on this vessel includes a manual latch with a self-locking feature.

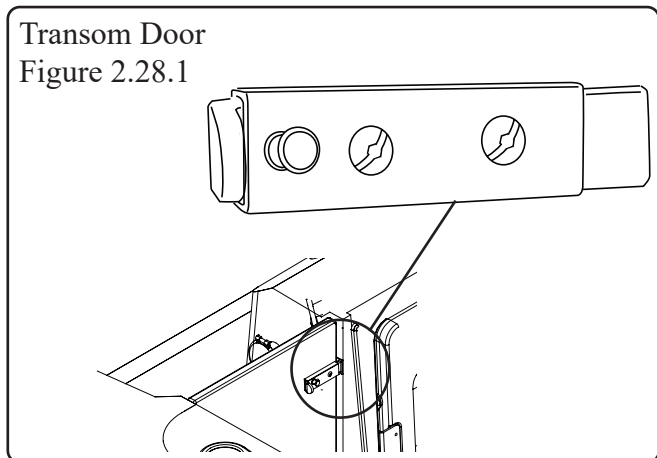

Opening Transom Door

Pull out on the self locking button and pull the latch out to release door.

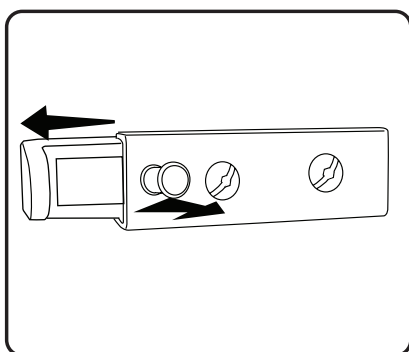

Locking Transom Door

Close the door and push the latch into the receiver on the door frame. When the latch is fully seated, the locking button will snap into place, securing the latch.

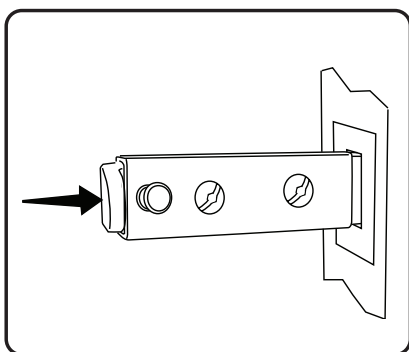

! WARNING

The transom door should be closed and secured when the engines are running and the boat is underway.

Docking, Lifting and Trailering

Cleat Locations
Figure 2.28.2

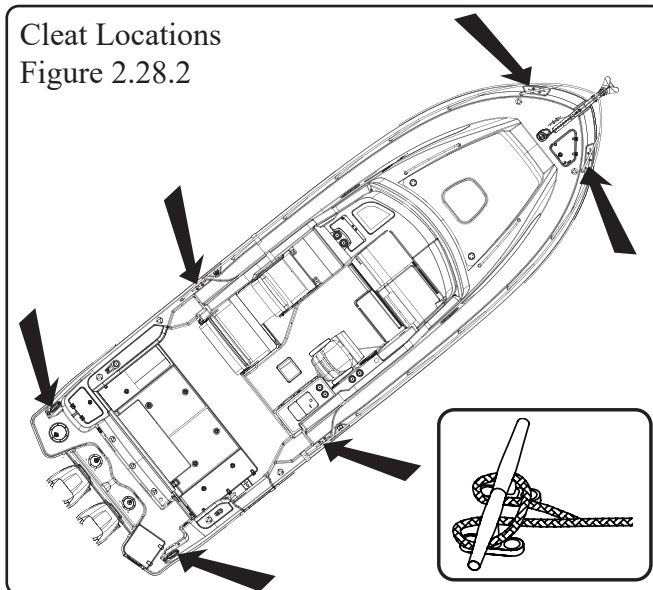

Docking

This vessel has six cleats used for docking, Two at the bow, two amidships, and two pop up cleats at the stern (see Figure 2.28.2). The cleats are used to secure the boat to the dock while loading/unloading or mooring. Figure 2.28.3 shows the correct method for tying a belaying knot, commonly used to secure a boat to a dock. This knot will hold fast and is simple to release when needed.

Belaying Knot
Figure 2.28.3

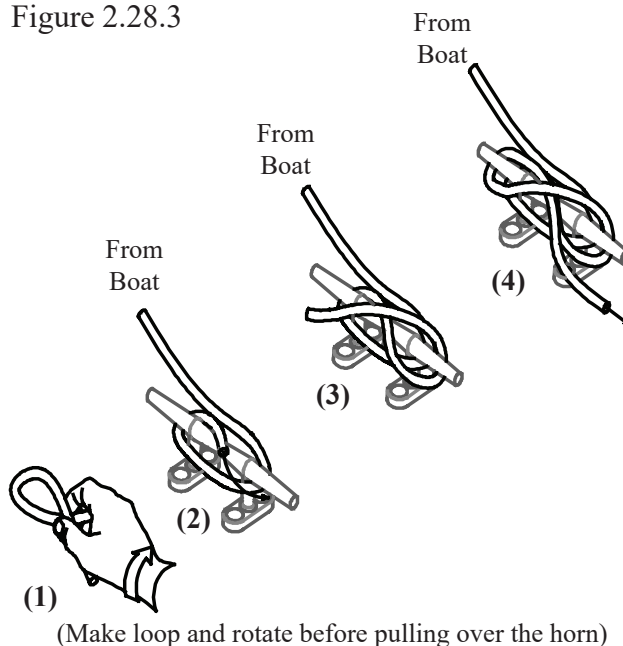

Lifting

The bow eye is used to haul out and hold this vessel onto a trailer. The stern eyes are used as tie down points while trailering the boat. The bow and stern eyes may be used only for short term lifting of the boat such as service. For long term lifting or storage, use flat, wide belt-type slings and spreaders long enough to keep pressure from gunwales. Do not allow slings to contact underwater fittings.

NOTICE

Close A/C Seacock

Before removing this vessel from the water be sure to close the A/C seacock. Failure to do so will cause an air lock in the line when the boat is returned to the water. The A/C system must be primed to operate properly.

⚠ DANGER

Use only the lifting points specified. Using the cleats for lifting is dangerous and could cause serious injury or death.

⚠ CAUTION

Long term lifting with the bow and stern eyes can cause stress on the fiberglass and gel coat and is not recommended.

Proper Short Duration lifting
Figure 2.29.1

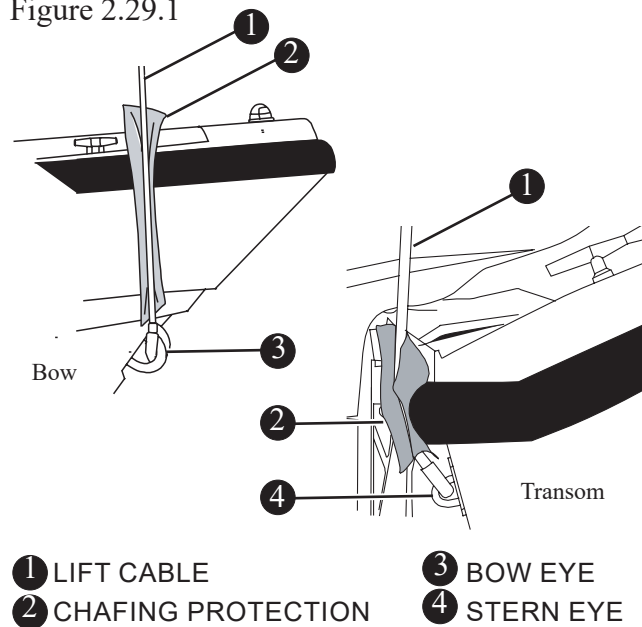

Whether lifting this vessel out of the water for routine maintenance or long term storage, consider the following:

- If you are using a professional lifting service, check all credentials and ask for proof of insurance to protect your investment.
- Use a wide, flat, belt-type sling for lifting to minimize stress on the gunwales. Careful location of the sling is required. Sling labels are installed at four spots on the gunwale that should be used as a guide for sling placements.
- If using a lifting hook, attach to bow eye and the stern lifting eyes mounted on the transom
- Always use a spreader bar on the stern eyes and use chafing protection on the top of the transom.
- All drain plugs (i.e. transom, fishwell, deck, etc.) should be pulled out and the boat positioned with the bow slightly higher than the stern so that any water which is allowed to accumulate in the cockpit and/or bilge can easily drain from the boat.

Propeller

⚠ DANGER

Disconnect power by moving the battery switches to the off position prior to removing the propeller for maintenance, etc.

⚠ WARNING

Rotating propeller may cause serious injury or death. Shut off engine when near persons are in water.

NOTICE

- **Always carry spare propellers, propeller hardware and a propeller wrench on board. Should your propellers become damaged they can then be easily replaced.**
- **Under no circumstance should you use a propeller which allows the engine to operate at a higher than recommended RPM.**

The engine on your vessel has been equipped with a propeller for general use under normal conditions and load. In some situations you may wish to change the propeller to give this vessel slightly different performance characteristics.

Propellers have two basic characteristics, diameter and pitch. Diameter is that distance measured across the propeller hub from the outer edge of the 360 degrees that is made by the propeller's blade during a single rotation. Pitch is that distance in inches that a propeller will travel if rotated one revolution without any slippage.

In general, changing to a lower pitch propeller will increase acceleration and load pulling capability, with a slight decrease in top end speed. If you choose to change propellers, the type should be discussed with your Boston Whaler dealer.

All propellers are designed to provide maximum forward thrust. Consequently, the reverse thrust of the propeller will not be as efficient.

Underwater Lights (Option)

If equipped, the three underwater lights are located on the transom just below the surface of the water (see Figure 2.30.1). When lit, the lights illuminate the water in a translucent blue glow which enhances the after dark experience of being on the water. In addition the lights occasionally may attract a myriad of marine life.

The underwater light switches, labeled *U/W LTS*, are located on the helm switch panel. The lights are protected by the *ACC I* breaker on the main DC distribution panel located behind an access door beneath the companion lounge seat.

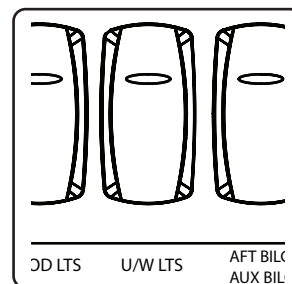

Underwater lights (Option)
Figure 2.30.1

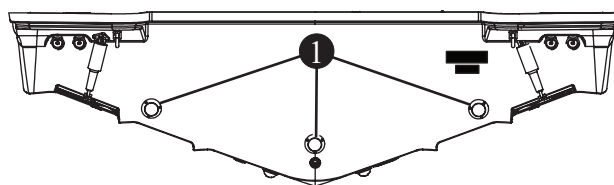

① UNDERWATER LIGHTS

⚠ CAUTION

Underwater lights are not to be used when navigational lights are in use as this may interfere with the effectiveness of the navigational lights.

Pilothouse (option)

The pilothouse enclosure provides a closed, climate-controlled environment in the helm area (see Figure 2.31.1). Airflow in the helm can be improved by opening the windshield vents, hardtop hatches (option), and drop-down window.

The pilothouse includes a carbon monoxide (CO) detector which sounds an alarm when dangerous CO levels are detected. See chapter 1, *Safety*, for more information on the dangers of carbon monoxide.

⚠ DANGER

Never ignore an alarm.

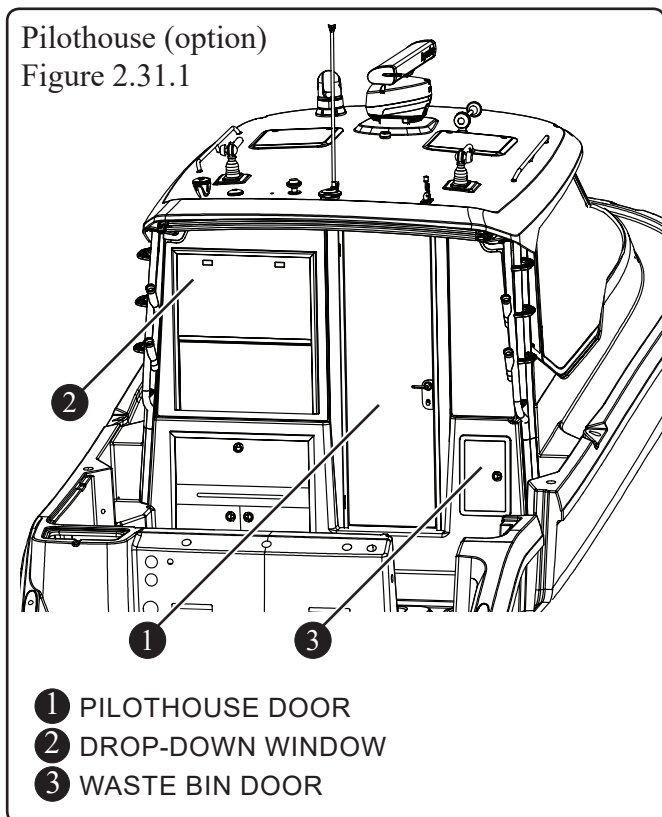

⚠ CAUTION

Close pilothouse door while underway.

Diesel Heater (option)

The pilothouse diesel heater provides heat to both the enclosed pilothouse and the cabin. The heater control is mounted overhead in the hardtop, while the heater unit, control module, and portable fuel tank are located inside the heater compartment (see Figure 2.31.2).

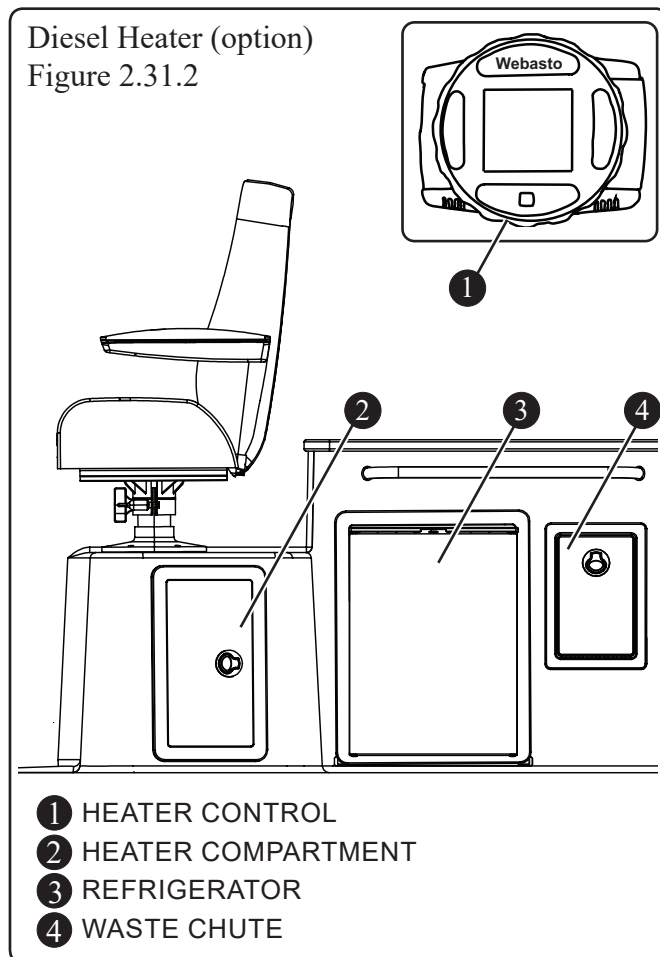

To fill portable diesel fuel tank:

- Loosen and remove tank's ground cable
- Use quick disconnect to remove fuel line from tank
- Unclasp tank strap
- Remove tank from tray

THIS PAGE INTENTIONALLY LEFT BLANK

Bilge Pumps

This vessel is equipped with three bilge pumps and a shower sump with pump and float switch (see Figure 3.1.1). The aft bilge pump and the high water bilge pump are rated at 2,000 GPH (7571 LPH) and the forward bilge pump at 1,100 GPH (4164 LPH). Each pump is activated by a float switch when the water in the bilge reaches a predetermined level.

A switch on the helm switch panel labeled *FWD BILGE* controls pump operation. The switches should remain in the *AUTO* position while in use or operated manually by depressing the switch to the *ON* position.

The bilge pumps and the shower sump discharge water overboard by way of thru-hull fittings. The aft pump and emergency high-water bilge pump can be

Aft Bilge Pumps

Figure 3.1.2

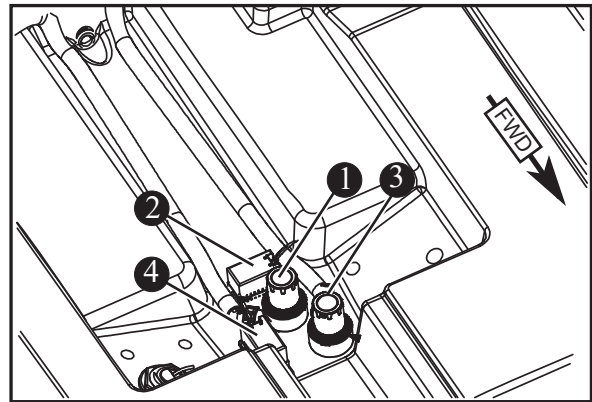

- ① AFT HIGH WATER BILGE PUMP
- ② HIGH WATER FLOAT SWITCH
- ③ AFT BILGE PUMP
- ④ AFT BILGE PUMP FLOAT SWITCH

Bilge Pumps and Shower Sump

Figure 3.1.1

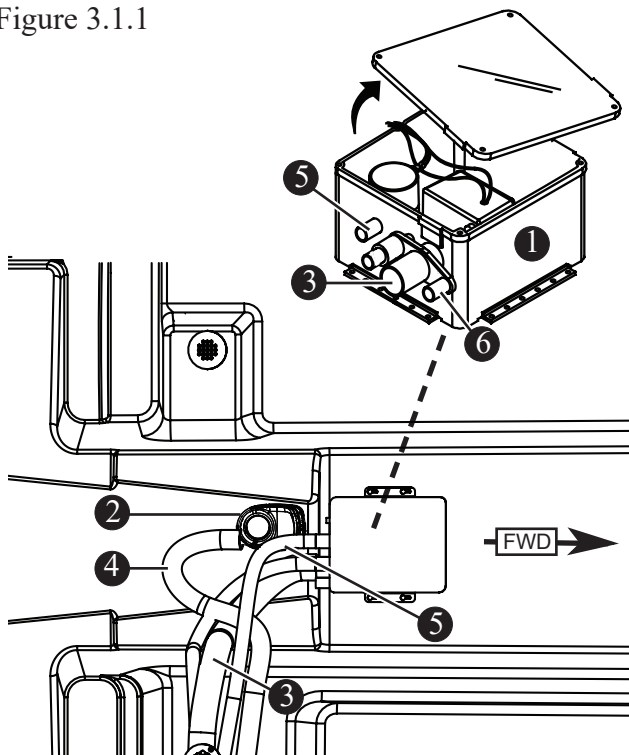

- ① SHOWER SUMP BOX
- ② MID CABIN BILGE PUMP
- ③ FROM SHOWER DRAIN
- ④ BILGE PUMP DISCHARGE
- ⑤ SHOWER SUMP DISCHARGE
- ⑥ FROM A/C CONDENSATION DRAIN

accessed through the mechanical access hatch in the cockpit deck (see Figure 3.1.2). The forward pump and shower sump can be accessed by lifting the hatch on the bottom cabin step and removing the trash can revealing and removing the cover. Access the shower sump pump by removing screws holding top on unit.

Bilge Pump Maintenance

Frequently inspect the area under all float switches to ensure they are free from debris and gummy bilge oil. To clean, soak in heavy-duty bilge cleaner for 10 minutes, agitating several times. Check for unrestricted operation of the float and repeat if necessary. Inspect the bilge pump intakes and keep them free of dirt or material which may impede the flow of water through the pump. To clean the pump strainer, depress the lock tabs on both sides of the pump and lift the pump motor (see Figure 3.2.1). If water does not come out of discharge hose:

1. Remove motor module to see if the impeller rotates with the power on.
2. Remove any debris that may have accumulated in the nozzle section or strainer base.
3. Check hose and connection on hull side for debris and proper connections.

BILGE PUMP AND FLOAT SWITCH
FIGURE 3.2.1

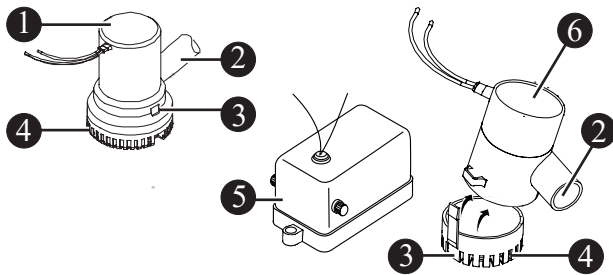

- 1 AFT BILGE PUMP
- 2 DISCHARGE
- 3 LOCK TAB
- 4 WATER INLET
- 5 FLOAT SWITCH
- 6 FORWARD BILGE PUMP

NOTICE

Bilge pumps are wired directly to the battery, therefore it is imperative that the float switch remain clear of debris to prevent continuous operation and subsequent battery discharge.

NOTICE

Inspect the bilge pump intakes frequently and keep them free of dirt or material which may impede the flow of water through the pump.

NOTICE

After using shower, run clean water through shower drain to flush out soap residue.

Fuel and Oil Spills

Regulations prohibit discharging fuel or oily waste in navigable waters. Discharge is defined as any action which causes a film, sheen or discoloration on the water surface, or causes a sludge or emulsion beneath the water surface. A common violation is bilge discharge. Violators are subject to severe penalties and may also be responsible for the cost of cleanup which could be substantial. Use rags or sponges to soak up fuel or oily waste, then dispose of properly ashore. If a large quantity of fuel or oil is in the bilge, contact your dealer to remove it. Never pump contaminated bilge discharge overboard.

Power Steering

The engines on this vessel incorporate power-assisted steering by use of an enclosed hydraulic pump accessed through a door next to the helm seat (see Figure 3.3.1). The pump is electrically operated to provide hydraulic pressure to the steering system.

Filling and Maintenance

The system is virtually maintenance free, aside from regular fluid checks and visually inspecting the outside of the unit for signs of leaks or damage. To add power steering fluid:

- Release rubber locking strap
- Unscrew and remove power steering reservoir cap; check the fluid level in the reservoir. If necessary add SAE 0W-30 synthetic power steering fluid only.
- Replace cap and reattach cover. Check fluid level before each trip.

POWER STEERING
FIGURE 3.3.1

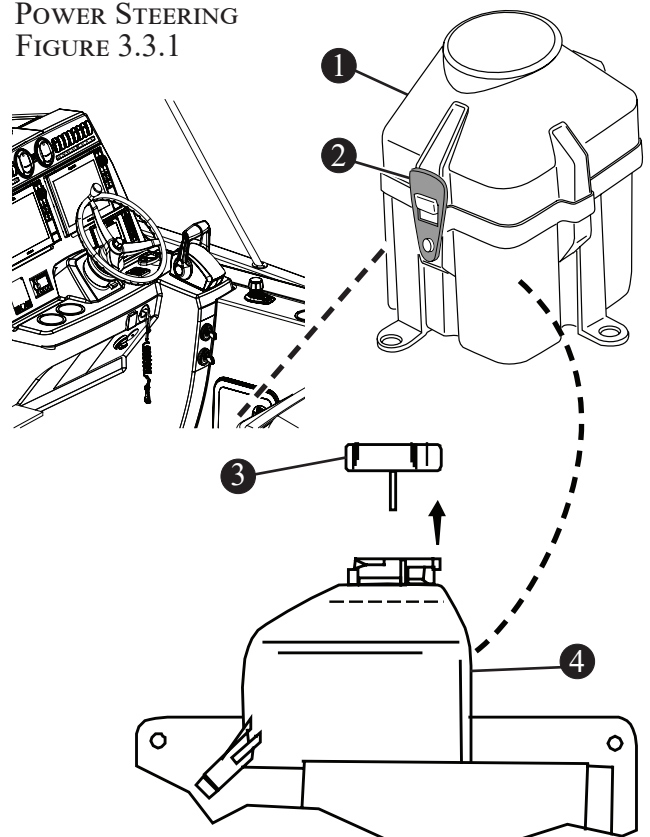

- 1 REMOVABLE COVER
- 2 RUBBER LOCKING STRAP (2)
- 3 SCREW-ON CAP
- 4 POWER STEERING FLUID RESERVOIR

Fuel System

CAUTION

- Oil and fuel spills can be dangerous and can subject offenders to severe penalties.
- Leaking fuel is a fire and explosion hazard; inspect system regularly. Examine fuel tanks and exposed lines for leaks and corrosion.

CAUTION

Use of improper fuel can seriously damage your engine. Engine damage resulting from use of improper fuel is considered engine misuse and voids the warranty. Follow engine manufacturer's recommendations regarding the types of fuel and oil to use.

NOTICE

It is your responsibility to read and understand the engine manufacturer's manual in your owner's packet for complete fuel and fueling information and warnings.

The fuel system (see Figure 3.4.1) is designed to meet EPA regulations using certified components to limit fuel vapor emissions. Features include:

- Automotive style refueling, automatic nozzle shut-off, fuel nozzle retention. This system sends a signal to the pump nozzle to shut off before there is any spit-back or well-back through the fill opening.
- Overfill protection reduces the possibility of accidental fuel spills.
- Reduce hydrocarbon emissions through the use of a specially-designed fuel fill. This fuel fill cap has a positive closure mechanism with an audible click when sealed.

Fuel Tank

NOTICE

Fuel gauge only reads accurately when boat is level (not underway).

The low-permeation aluminum fuel tank has a usable fuel capacity of 291 gallons (1102 L). The non-usable portion of the tank is fuel that is below the pickup

tube and the ullage area that has been incorporated. Read and understand all fuel-related information and warnings in the owner's packet. Fuel tanks less than 1/4 full can cause engine stalling problems due to fuel starvation or by allowing sediment to enter fuel lines. Keep tank full and monitor fuel level often.

Fuel Vent

The fuel tank vent is integrated into the fuel fill deck fitting. The VaporTec fuel pressure management system (fuel fill deck fitting, integrated check valve, fill limit vent valve, and grade valve) ensures that the fuel system maintains proper vapor pressure, which, if unchecked, can seriously damage a boat or engine. The vent serves as an over pressure/vacuum release with anti-surge and flame/spark arresting protection. Grade valves have been added to the tank to allow proper ventilation when the boat is stored, or trailered, on a moderate incline, without fuel seepage.

Fuel Distribution System

Fuel is delivered to the engines through the fuel valves, anti-siphon valves (ASV) and the fuel lines. The fuel valves prevent built up tank pressure from being transferred to the engines while still allowing fuel to flow. The anti-siphon valve is a safety feature designed to prevent fuel from siphoning out of the tank if the fuel line were to be cut or broken below the level of the fuel in the tank. While some fuel would leak, the entire contents wouldn't siphon out.

Filling the Tank

WARNING

The fuel system on this vessel complies with all applicable ABYC standards. Fueling station pump flow rates that exceed 18 gallons (68 liters) per minute may damage system components and cause fuel leakage into the vessel.

The fuel system automatically shut off the fuel nozzle when the tank is full. The tank is filled when the fuel fill nozzle has shut itself off the second time. The SecureStop automatic fuel shut off system (fuel fill deck fitting, integrated check valve, fill limit vent valve), ensures a clean a trouble-free fill-up. Attempting to fill the tank past this point may cause some components to malfunction.

FUEL SYSTEM
FIGURE 3.4.1

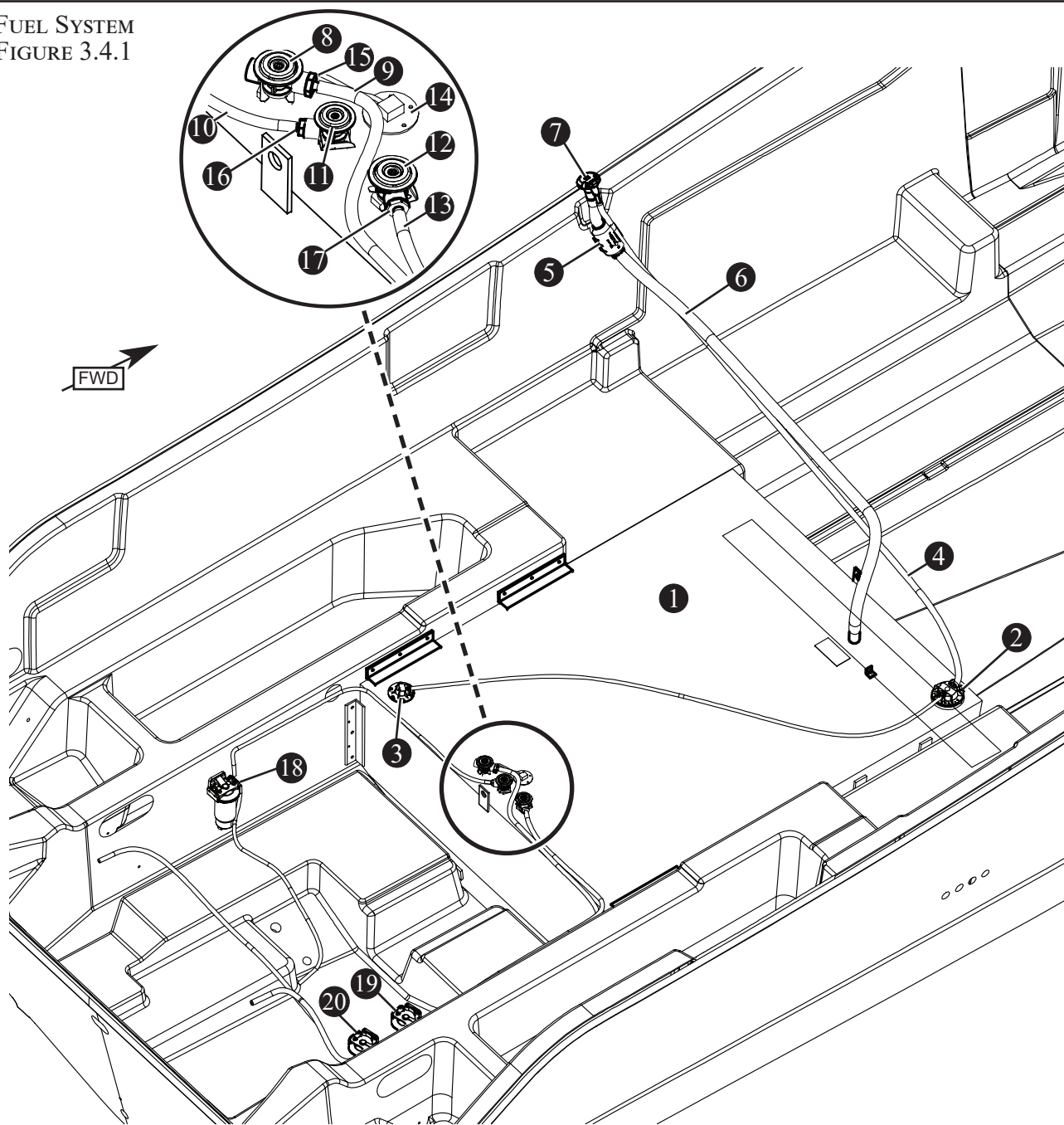

- | | | |
|-------------------------|--------------------------------|----------------------------|
| 1 FUEL TANK | 8 PORT ENGINE FUEL VALVE | 15 PORT ENGINE ASV |
| 2 FILL LIMIT VENT VALVE | 9 PORT ENGINE FUEL FEED | 16 GENERATOR ASV |
| 3 GRADE VALVE | 10 GENERATOR FUEL FEED | 17 STARBOARD ASV |
| 4 FUEL VENT HOSE | 11 GENERATOR FUEL DEMAND VALVE | 18 GENERATOR FUEL FILTER |
| 5 INLET CHECK VALVE | 12 STBD ENGINE FUEL VALVE | 19 STBD ENGINE FUEL FILTER |
| 6 FUEL FILL HOSE | 13 STBD ENGINE FUEL FEED | 20 PORT ENGINE FUEL FILTER |
| 7 FUEL FILL | 14 FUEL TANK SENSOR | |

WARNING

Use of a portable fuel container to fill fuel tank can result in overfilling and circumvent the safety features designed into fuel tank.

WARNING

Modification of any fuel system components or replacement of these components with unauthorized parts may result in over-pressurization of fuel system and circumvent safety features designed into tank.

NOTICE

Record this vessel's fuel capacity and consumption. Drastic changes in consumption and mileage may indicate a problem.

DANGER

- **Static electricity can ignite gasoline vapors causing serious injury, death and/or destruction of property.**
- **Check for leaks in tubing, connections and hoses. Avoid all forms of ignition when the fuel fumes are noticed.**
- **Correct the cause of the leaks and ventilate the area to insure that no fumes remain prior to energizing any electrical equipment, smoking and/or starting the engines.**

Static Electricity

Static electricity can ignite gasoline vapors that have not been ventilated outside an enclosed area. Use extreme caution when fueling this vessel from a source other than marinas and gas stations.

This vessel's bonding system protects it from creating and discharging static electricity. This vessel must be in contact with the water or a land-based grounding system. The following suggestions will help keep you safe from static electricity while refueling.

- Never fuel boat in unsafe conditions such as suspended on a sling or in a situation that increases the likelihood of static discharge.
- Never use homemade containers to fill tanks.
- Fuel carried on-board outside of a fixed fuel system should be stored in an approved container or in a portable tank such as provided for outboard engines and be stowed safely outside of the engine or living compartment(s).
- Shut down the engines, motors and fans prior to taking on fuel. Any ignition sources should be extinguished before filling the fuel tank.
- Close all ports, windows, doors and hatches.
- Fueling should never be done at night except in well-lit areas.
- Always keep fuel nozzle in contact with edge of the fuel tank opening when filling.
- Ventilate areas where gasoline vapors could collect before starting the engine.
- Wipe up any spillage completely and dispose of rags or waste on shore.
- Secure the fill cap tightly.
- Portable tanks should only be filled while on shore, never on board the boat.

REFER TO THE SAFETY DVD IN YOUR OWNER'S PACKET FOR MORE INFORMATION.

CAUTION

- **Oil and fuel spills can be dangerous and can subject offenders to severe penalties**
- **Leaking fuel is a fire and explosion hazard, inspect the system regularly. Examine fuel tanks and exposed lines for leaks and corrosion.**

NOTICE

It is your responsibility to read and understand the engine manufacturer's manual in your owner's packet for complete fuel and fueling information and warnings.

Ethanol-Blended Fuel

NOTICE

The use of improper gasoline or additives can damage your fuel system and is considered misuse of the system. Damaged caused by improper gasoline or additives is not covered under warranty.

CAUTION

The use of fuels containing ethanol higher than 10 percent (E-10) can damage your engine and/or fuel system and will void the warranty.
E85 FUELS COULD SERIOUSLY DAMAGE YOUR ENGINES AND MUST NEVER BE USED.

Ethanol has a high octane rating and therefore may be useful in increasing the octane level of unleaded gasoline. The fuel-system components of Mercury engine(s) have been tested to perform with the maximum level of ethanol-blended gasoline (10 percent) currently allowed by the U.S. EPA.

Special precautions should be considered with the use of fuel containing ethanol in your system. Fuels with ethanol can attack some fuel-system components, such as tanks and lines, if they are not constructed from ethanol-compatible materials. This can lead to operational problems or safety issues such as clogged filters, leaks or engine damage.

This vessel was manufactured and shipped from the factory with ethanol-compatible materials. Before introducing gasoline with ethanol into your fuel tank, ask your dealer if any components have been added or replaced that are not recommended by Boston Whaler, Mercury, or may not be ethanol-compatible.

It is best to maintain a full tank of fuel when the vessel is not in use. This will reduce air flow in and out of the tank due to changes in temperature as well as limiting ethanol exposure to humidity and condensation in the tank.

Phase Separation

Humidity and condensation create water in your fuel tank which can adversely effect the ethanol blended fuel. A condition called phase separation can occur if water is drawn into the fuel beyond the saturation point. The presence of water in the fuel beyond the saturation level will cause most of the ethanol in the fuel to separate from the bulk fuel and drop to the bottom of the tank, significantly reducing the level of ethanol in the fuel mixture in the upper level (phase). If the lower level (phase), consisting of water and ethanol, is deep enough to reach the fuel inlet, it could be pumped directly to the engine(s) and cause significant problems. Engine problems can also result from the reduced ethanol/fuel mixture left in the upper phase of the tank.

There is no practical additive known that can prevent or correct phase separation. The only solution is to keep water from accumulating in the tank. If phase separation does occur, your only remedy is to drain the fuel, clean and dry the tank completely and refill with a fresh, dry load of fuel.

Fuel/Water Separators

Fuel water separators (filters) are provided for both engines and the generator. The addition of another in-line filter to the system may create a possible flow restriction that can starve the engine(s) of fuel. It is advisable to carry extra on-engine filters in case filter plugging from debris in the fuel tank becomes a problem during boating. Consult your Boston Whaler dealer for recommendations regarding filters that meet Mercury's specifications.

Maintenance

Periodically inspect for the presence of water in the fuel tank. If any is found, all water must be removed and the tank completely dried before refilling the tank with any fuel containing ethanol.

Boat Storage

Long periods of storage and/or non-use, common to boats, create unique problems. When preparing to store a boat for an extended period of two months or more, it is best to completely remove all fuel from the tank. If not possible, maintaining a full tank of fuel with a fuel stabilizer added to provide fuel stability and corrosion protection is recommended. Use of fuel stabilizer:

- Add fuel stabilizer/treatment per manufacturer's instruction.
- Run engine(s) for 10 minutes.
- Shut off fuel valve; run engine until it stops.
- Top off fuel tank, leaving space for expansion.
- Do not cap the tank vent.

Maintaining a partially-full tank during storage is not recommended because the void above the fuel allows air movement that can introduce water through condensation.

Starting the Engines

CAUTION

To prevent damage to water pump or engine overheating, never start or operate engine(s) (even momentarily) without water circulating through cooling water intakes in the gear case.

Pre-start Check

- Ensure lower unit of the engine is in the water.
- Be sure the emergency engine shutoff switch is in the *RUN* position.
- Be sure gear shift and throttle control levers are in the *NEUTRAL* position.
- Make sure the remote battery switch is in the *ON* position (see Figure 3.7.1).

NOTICE

The gear shift/throttle control levers will not allow engine starting if the control levers are in any other position than neutral.

Remote Battery Switch
Figure 3.7.1

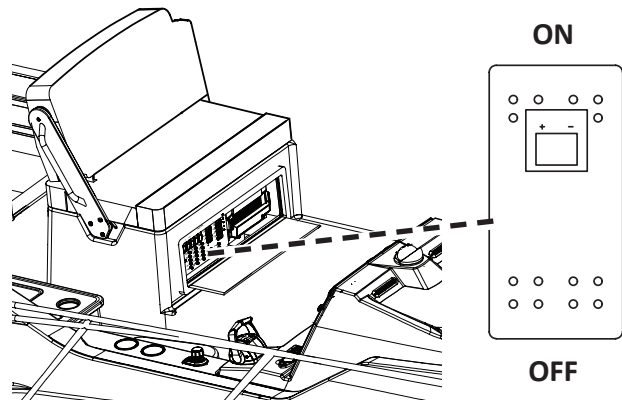

NOTE: HELM SEAT REMOVED TO PROVIDE CLARITY.

Start Procedure

- Turn one ignition switch (see Figure 3.7.2) to the *Start* position momentarily to start engine; repeat for second ignition switch.

Ignition Switches
Figure 3.7.2

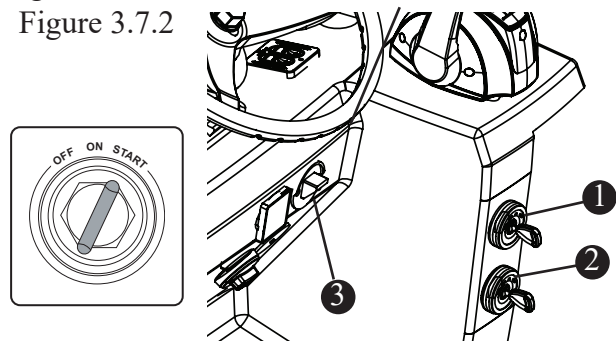

- 1 PORT ENGINE IGNITION SWITCH
- 2 STARBOARD ENGINE IGNITION SWITCH
- 3 ENGINE SHUT-DOWN SWITCH

Warming Engine(s)

The *THROTTLE ONLY* button (see Figure 3.8.1) on the gear shift/throttle control allows the operator to increase engine RPMs without shifting into gear. Ensure the gear shift and throttle control handle are in the *NEUTRAL* position. Hold in the *THROTTLE ONLY* button until two audible beeps are heard and the neutral lights start flashing. The flashing lights indicate that the throttle only function is engaged.

Operation

- Advance handles to increase engine RPMs.

NOTE: RPMs are limited to prevent engine damage.

- To disengage, return handles back to neutral position and press *THROTTLE ONLY*.
- The warm-up mode can be re-activated by turning engines off and re-starting.

Stopping the Engine(s)

- Be sure gear shift and throttle handle are in *NEUTRAL* position.
- Turn key to *OFF* position.
- Turn battery switch *OFF*.

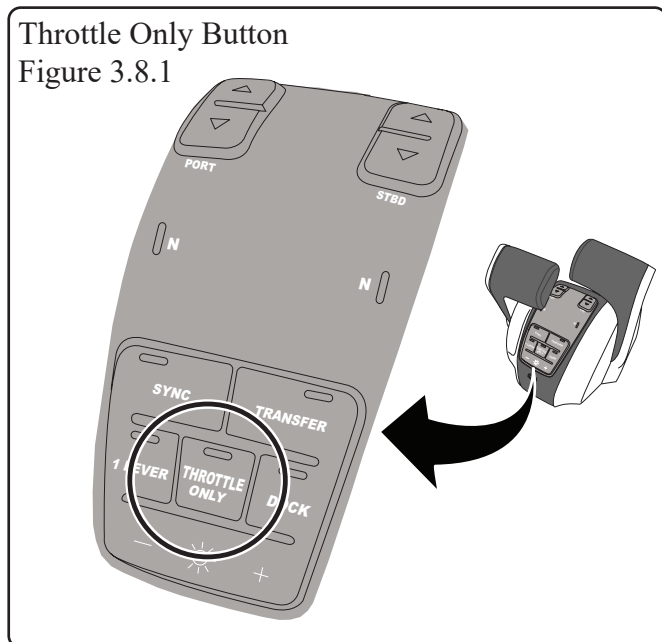

CAUTION

Never turn battery switch to OFF position while engine is running. Equipment damage will occur.

REFER TO THE ENGINE MANUFACTURER'S MANUAL IN OWNER'S PACKET FOR COMPLETE INSTRUCTIONS AND WARRANTY INFORMATION.

Fresh Water System

NOTICE

- **Be sure to fill water tank from a source known to provide safe, pure drinking water.**
- **If you do not use the freshwater system for long periods of time or only use it seasonally it is recommended that you disinfect the system before using it.**

The freshwater system (see Figure 3.9.1) on this vessel includes a 46 gal. (174 L) fresh water tank and pump providing water service to the sink/shower in the head, galley sink, toilet and transom shower.

Filling Fresh Water Tank

The water tank can be filled through the water fill inlet located on the portside gunwale (see chapter 2, *General Information*). All components of the vessel's freshwater system are FDA approved and can be used as a source of potable water. Fill the tank from a source known to provide safe, pure drinking water. Only use plastic hose to fill the water tank. Using a rubber hose can give the water a disagreeable taste. The hose should be dedicated to filling use only and should be stored in a clean, dry place. Cover the hose ends to ensure it stays clean.

Before you fill the freshwater system it is vital that it be properly disinfected. Refer to chapter 5, *Care & Maintenance* for disinfection instructions.

Fresh Water System
Figure 3.9.1

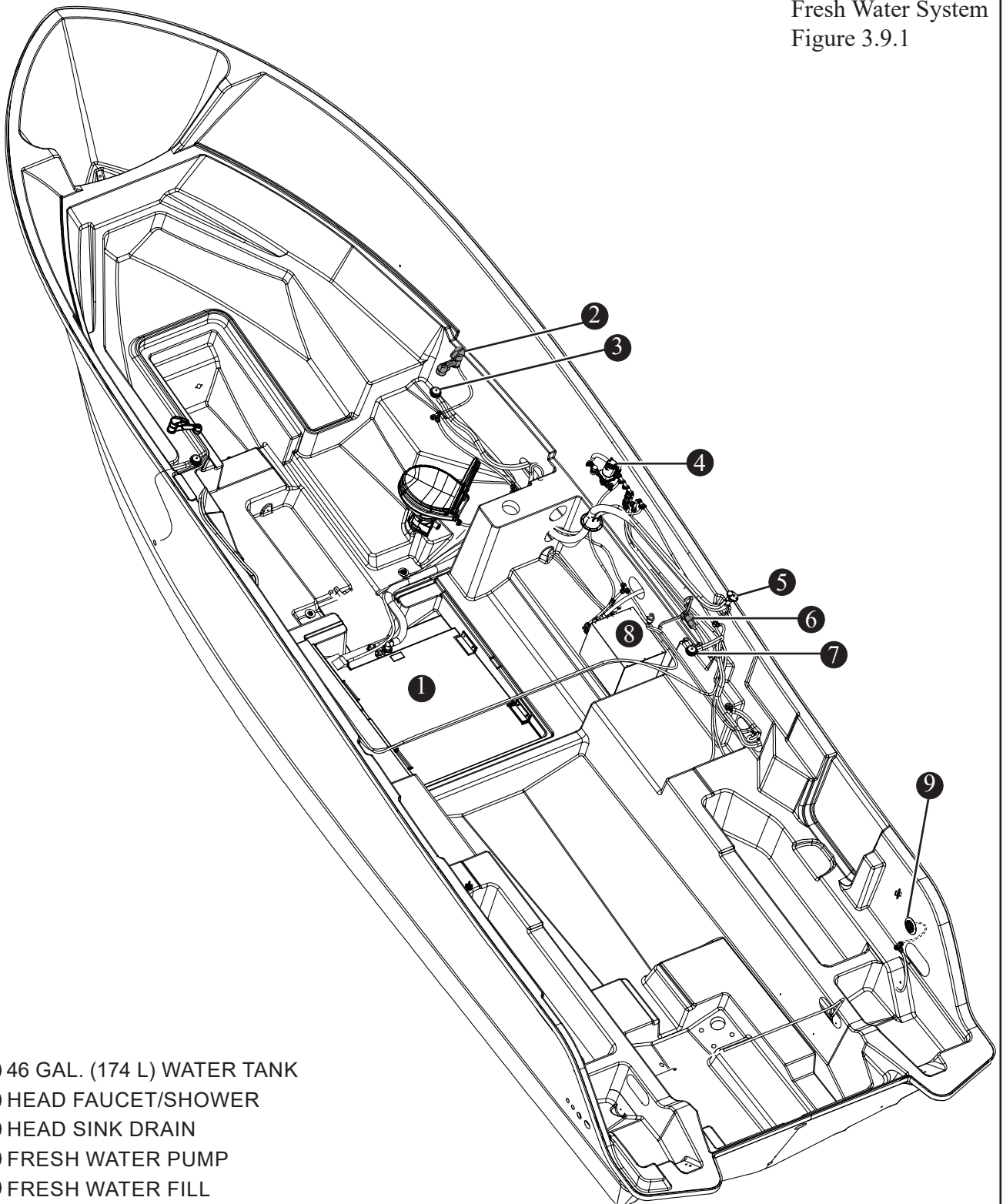

- ① 46 GAL. (174 L) WATER TANK
- ② HEAD FAUCET/SHOWER
- ③ HEAD SINK DRAIN
- ④ FRESH WATER PUMP
- ⑤ FRESH WATER FILL
- ⑥ PREP STATION FAUCET
- ⑦ PREP STATION SINK DRAIN
- ⑧ WATER HEATER (OPTION)
- ⑨ TRANSOM SHOWER

NOTE: GALLEY FAUCET AND DRAIN NOT SHOWN.

Fresh Water Pump

The fresh water pump (see Figure 3.10.1) draws water from the water tank and provides pressurized water to the galley faucet, head compartment, transom shower, and the prep station. To energize the system, turn on the *FRESH WATER* switch located on the DC main distribution panel.

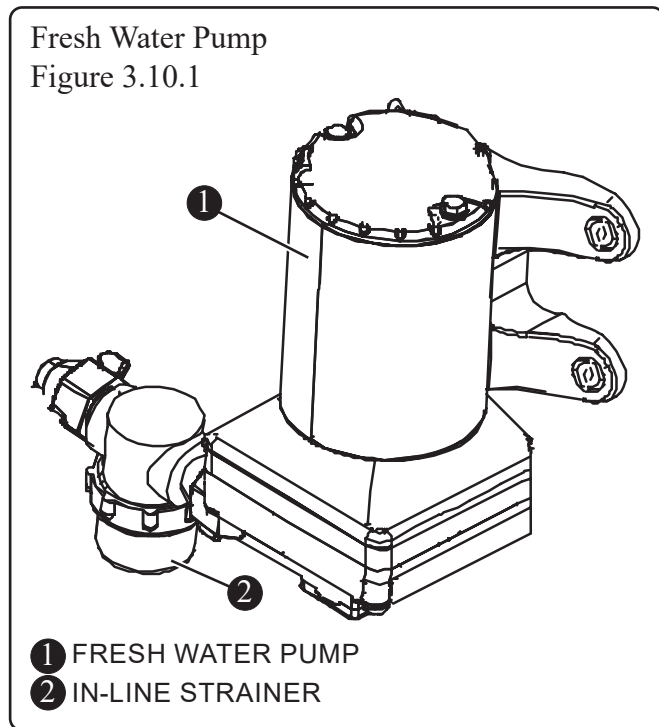

Maintenance

Maintenance of the fresh water system requires regular inspection of the fittings and hoses for system integrity to prevent leaks. Periodically check the in-line strainer attached to the fresh water pump, and clean if necessary. The system should be run at least every other month to maintain the pump's impellers in good operating condition. The fresh water pump is located at the side of the helm station.

Head Sink/Shower

The head sink faucet is attached to a hose and is also used for showering. There is a hook on the forward wall of the compartment to hang the spray head on when pulled out from its base on the faucet. A drain in the floor of the compartment discharges the used water overboard.

Transom Shower

The transom shower (see Figure 3.10.2) is located outside the transom door. The shower unit is

pressurized by the fresh water pump and the spray head is activated by twisting the center of the unit.

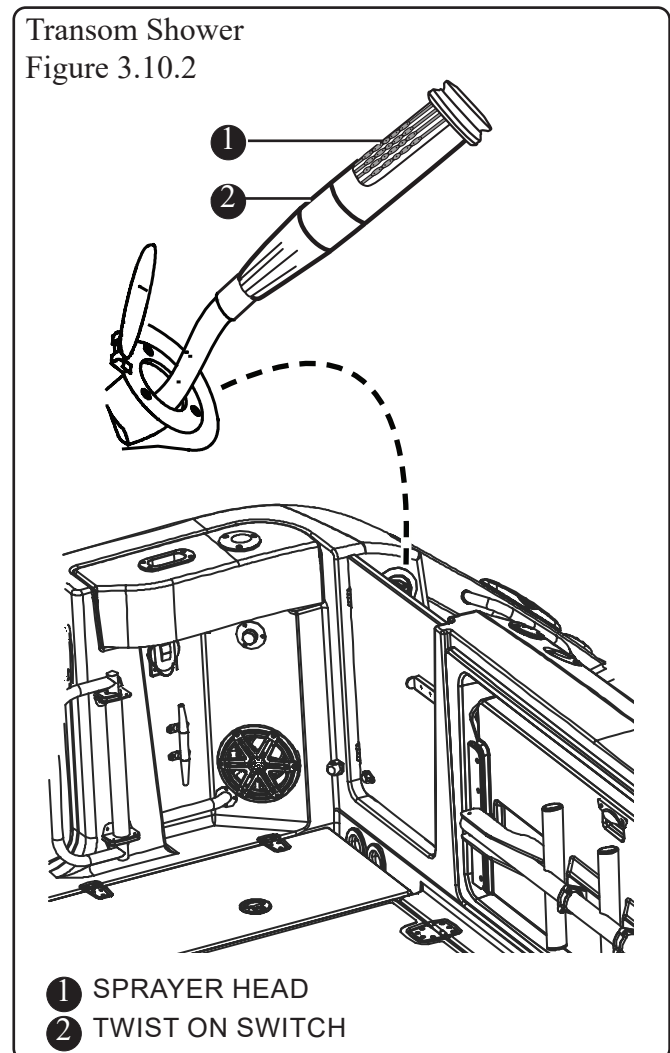

Water Heater (Option)

NOTICE

Make sure the fresh water tank is full before operating the water heater. Running the water heater until empty will damage the system.

Make sure the *FRESH WATER* switch is on before energizing the water heater. Turn on the *WATER HEATER* switch located on the AC main distribution panel. Once both the *FRESH WATER* switch and the *WATER HEATER* switches are on, the system can be utilized. If the unit has not been used for some time it takes approximately 20 minutes to heat up.

NOTICE

The water heater is equipped with a temperature and pressure relief valve.

WARNING

Hydrogen gas may form in tank if system has not been used for more than two weeks. Do not smoke or have any flame near an open faucet.

CAUTION

Scalding injury - Turn off water heater and wait for water in storage tank to cool before opening drain valve to flush tank.

Tempering Valve

A tempering or mixing valve is installed on the hot water outlet of the water heater (see Figure 3.11.1) to reduce the risk of scalding. The valve is set at it's lowest temperature (100°F) at the factory. The water

temperature can be adjusted up to a maximum of 130°F by turning the valve counterclockwise until the desired temperature is reached.

Maintenance

Water heater connections need to be inspected regularly. Access to the water heater can be made through an access panel on the starboard side of the mid berth. If you notice any leaks around the water heater contact your dealer. Manually operate the pressure relief valve at least once a year. This must be done when the water in the storage tank is cool.

The system must be flushed several times per year, which helps prolong the life of the system. There is a protective cladding in the tank that protects it from corrosion. The electro-galvanic action of the cladding material releases hydrogen from the water. If sulfur or any of its combinations are present the two will combine and produce hydrogen sulfide. This compound produces a rotten egg odor. Hydrogen sulfide can also be present in your freshwater supply.

Water Heater (Option)
Figure 3.11.1

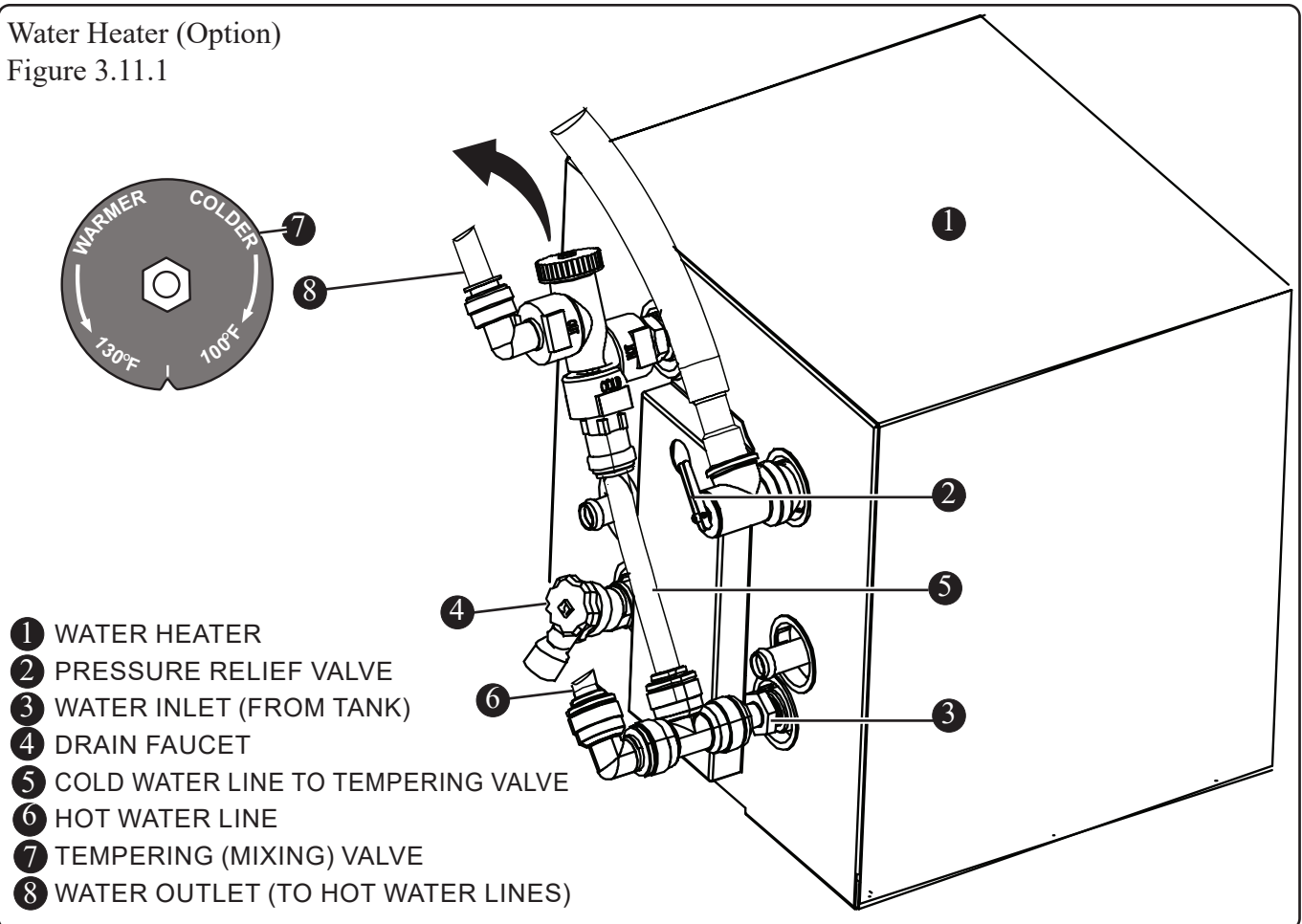

Even minute amounts of decaying animal matter can cause a perceptible odor. Make certain that the system is completely drained before laying up for the winter season. The freshwater tank must be drained and flushed with a non-toxic anti-freeze before winter storage.

REFER TO OWNER'S PACKET FOR COMPLETE INSTRUCTIONS AND WARRANTY INFORMATION.

Livewell

The livewell located on the port side of the stern deck keeps baitfish alive by circulating fresh seawater through the tank (see Figure 3.12.1 and Figure 3.13.1).

Operation

Before operating the system make certain the intake seacock and flow control valve are in the open position. The seacock can be accessed through the mechanical access hatch (see Figure 3.13.1). The flow control valve allows water flow adjustment into the livewell tank. Turn the handle clockwise to stop the flow of water.

Fill the livewell by pressing the switch marked *LIVEWELL* on the helm switch panel. A drain tube connects to the livewell overflow drains and directs overflow water to a transom thru-hull drain.

You can regulate the amount of water in the livewell by inserting the drain plug into the lower drain thus raising the level of water to the overflow drain.

ATTENTION

The seacock must be in the open position when livewell is in use. Running the pump dry may damage the unit.

Livewell Tank
Figure 3.12.1

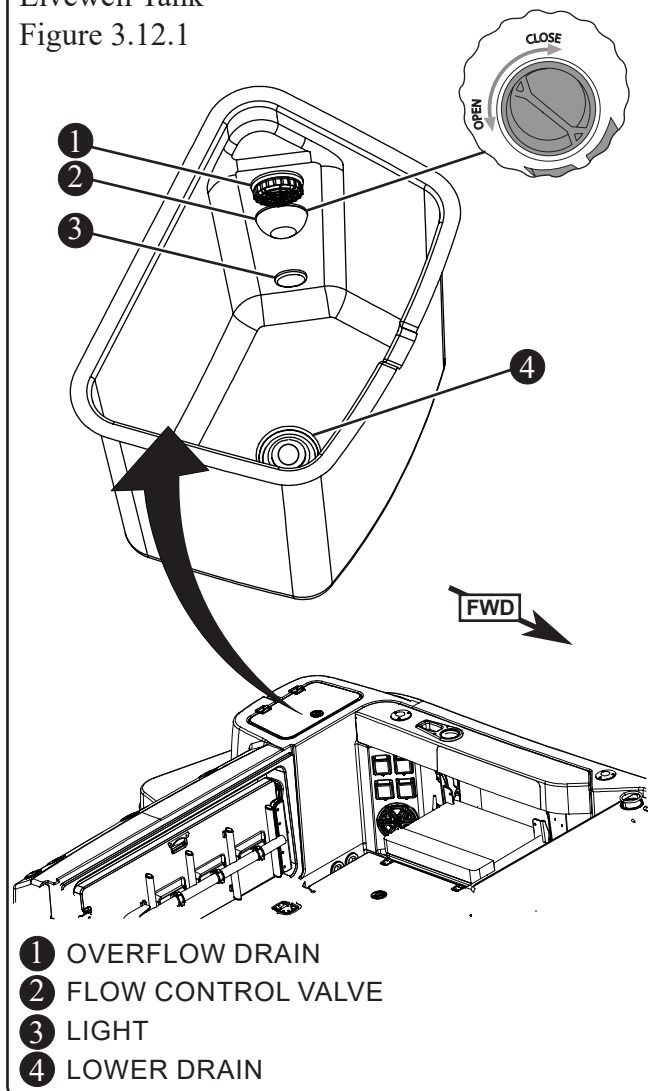

Livewell System Maintenance

Maintenance of the livewell system requires periodic inspection of the raw water intake strainer and all hose connections. Clean away debris and/or tighten hose connections as required.

Livewell System
Figure 3.13.1

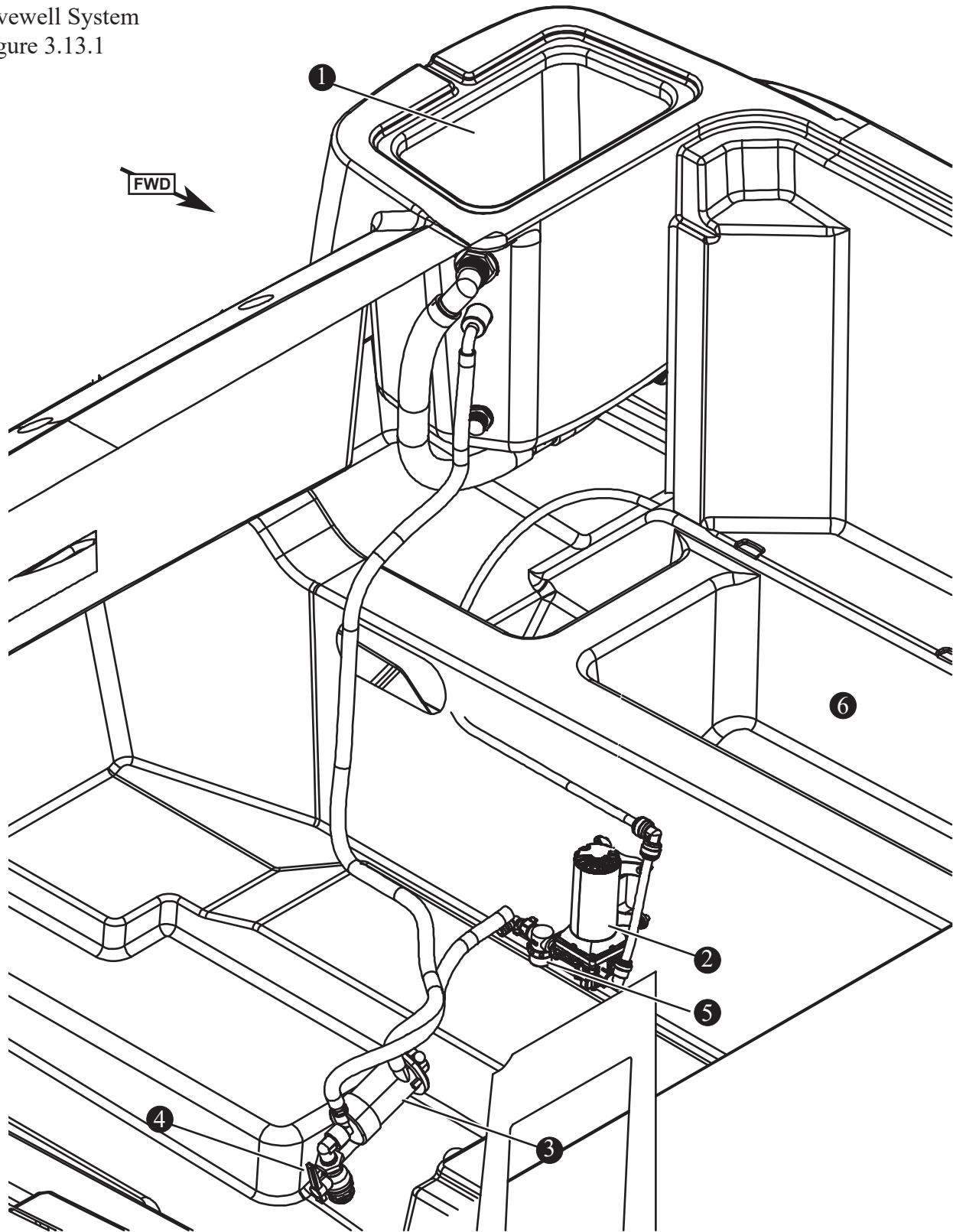

- | | |
|-----------------------------------|-----------------------------|
| ① LIVEWELL TANK (COVER NOT SHOWN) | ④ LIVEWELL SEACOCK |
| ② RAW WATER PUMP | ⑤ RAW WATER INTAKE STRAINER |
| ③ LIVEWELL PUMP | ⑥ PORT FISHBOX |

Raw Water Washdown

The raw water washdown hookup is located on the port gunwale of the cockpit. It is supplied by a 3.5 GPM pump (see Figure 3.14.1) activated by the *RAW WATER PUMP* switch on the battery switch panel.

Operation

Before operating the system make certain the raw water seacock is in the open position. The seacock can be accessed through the mechanical access hatch.

Maintenance

Maintenance of the raw water system requires checking the fittings and hoses for system integrity to prevent leaks. Periodically check the in-line strainer attached to the pump, and clean if necessary.

The system should be run at least every other month to maintain the pump's impellers in good operating condition. The raw water pump can be accessed through the mechanical access hatch.

ATTENTION

The seacock must be in the open position when livewell is in use. Running the pump dry may damage the unit.

Raw Water Pump
Figure 3.14.1

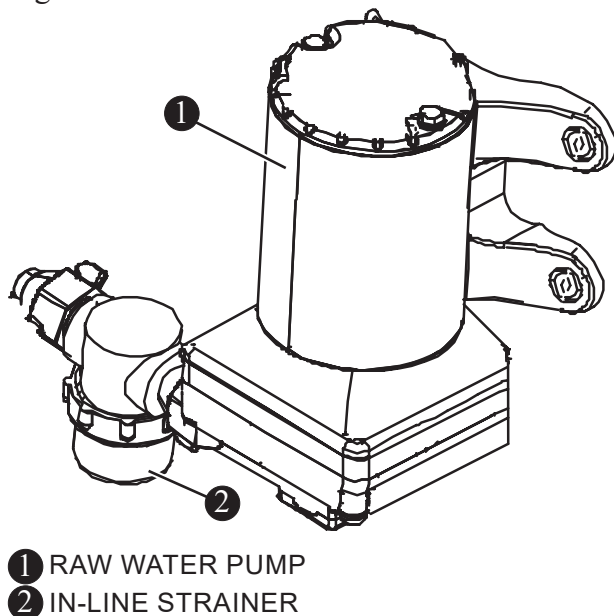

- ① RAW WATER PUMP
- ② IN-LINE STRAINER

Fishbox with Pump Out Discharge

The two 40-gallon, deep-well fishboxes located port and starboard in the cockpit utilize a pump system for each box to discharge water overboard by way of thru-hull fittings port and starboard. In addition, there is a bottom drain with a plug in each of the compartments (see Figure 3.14.2). The discharge pumps can be accessed through the mechanical access hatch. The pumps are independently activated by the *PORT F/B* and *STBD F/B* switches on the helm switch panel and are protected by breakers located on the battery switch panel. If the pumps fail to activate when the switches are depressed check the breakers first and reset if needed.

Fishbox Drain
Figure 3.14.2

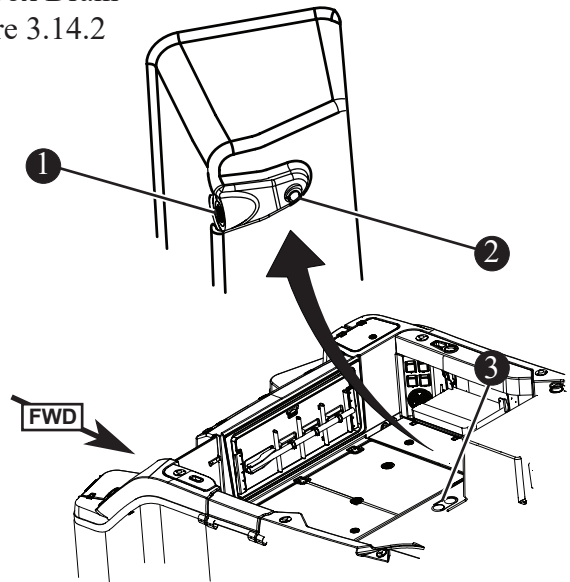

- ① PUMP OUT DISCHARGE DRAIN
- ② FISHBOX DRAIN
- ③ FISHBOX

! WARNING

The two fishbox drain plugs must be installed before putting boat into the water.

Bait Prep Station

This boat features a bait prep station located behind the helm seat. The integral swivel faucet is pressurized by the fresh water pump which provides cold running water to the station.

Head System

Environmental Considerations

The Environmental Protection Agency (EPA) standards state that in freshwater lakes, reservoirs, impoundments whose inlets or outlets are such as to prevent the ingress or egress by vessel traffic subject to this regulation, or in rivers not capable of navigation by interstate traffic subject to this regulation, marine sanitation certified by the United States Coast Guard (U.S.C.G.) installed on vessels shall be designed and operated to prevent the overboard discharge of sewage, treated or untreated or any other waste derived from sewage.

The EPA standards further state that this shall not be construed to prohibit the carriage of Coast Guard certified flow through treatment devices which have been secured so as to prevent such discharges. They also state that the waters where a Coast Guard certified marine sanitation device permitting discharge is allowed include: Coastal waters, Estuaries, The Great Lakes and Intercoastal waterways, Freshwater lakes and Impoundments accessible through locks and other flowing waters that are navigable interstate by vessels subject to this regulation. (40 CFR, 140.3)

This vessel is equipped with a waste containment/disposal system. The system includes a VacuFlush® toilet, a 12 gal. (45L) holding tank with vacuum pump, macerator, lockable discharge seacock, dockside pump-out connection, and a thru-hull vent.

NOTICE

This boat is equipped with an overboard discharge seacock. Severe state and federal penalties are levied for discharging raw sewage and solid waste in waters where it is not permitted.

The macerator can be disabled by attaching a wire tie or padlock to the seacock or removing the seacock handle while in a closed position, which would avoid potential fines.

It is illegal for any vessel to dump plastic trash anywhere in the ocean or navigable waters of the United States.

Waste System
Figure 3.15.1

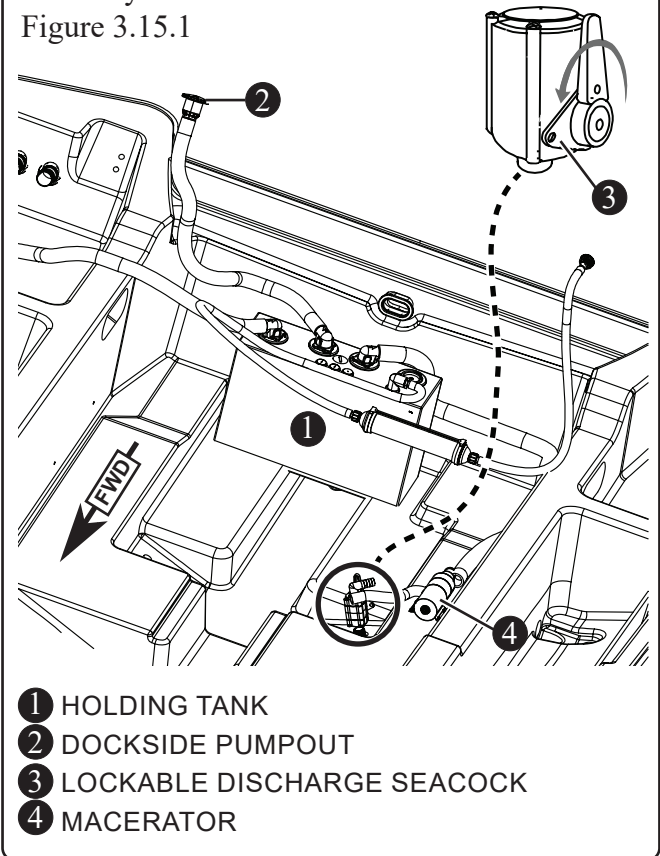

Macerator/Discharge Pump

The macerator/discharge pump (see Figure 3.15.1) draws solid and liquid waste from the holding tank and processes it prior to discharging it overboard through the macerator seacock located in the aft bilge. The macerator is designed to handle waste, toilet/ facial tissue and does not pump solid waste. The key used to actuate the overboard discharge unit can be found in the owner's packet.

NOTICE

The low-water consumption waste system requires the use of special paper to prevent clogs. The manufacturer has provided information regarding the type of paper that must be used. Never use residential tissue paper in your marine waste system.

CAUTION

The discharge seacock should always be in the closed position when the toilet is not in use. Failure to do so could result in flooding or property damage.

Macerator Operation

The *Head Panel*, is located on the wall of the head compartment and controls the macerator.

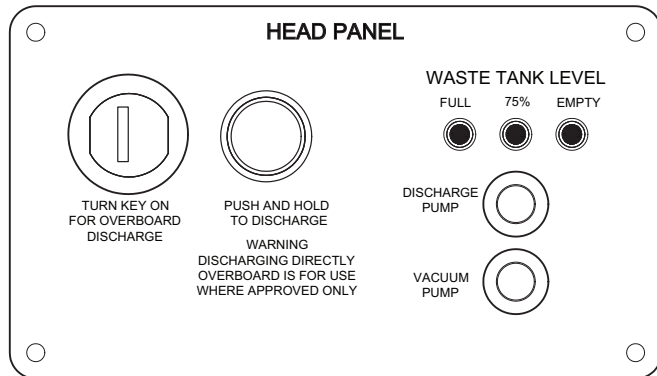

If the *FULL* light is on you must empty the holding tank before the system will function properly.

Macerator operation:

- Ensure discharge seacock is open.
- Insert macerator key (included in owner's packet) into head panel.
- De-energize vacuum pump by depressing push button/switch.
- Depress lever on toilet to deplete vacuum.
- Turn the key switch on, depress the discharge button (push and hold to discharge) until the entire contents of the tank has been discharged.
- Release the discharge switch, turn off the key switch, and remove the key.
- Energize system by depressing the push button/switch. The button will remain depressed.
- The system is now ready for normal operation.

There are bodies of water where discharge of raw sewage is prohibited. Keep the seacock lock engaged (see Figure 3.15.1) when in waters where discharge is not permitted.

Contact your dealer or local Coast Guard station for information on overboard discharge in your area and the penalties for non-compliance. Demonstrating that you have disabled the macerator by locking the system and/or removing the seacock handle may help you avoid a fine. To lock the discharge seacock, rotate handle until the hole in the handle is aligned with the locking plate hole; insert a padlock (not included).

Maintenance

After long periods of non-use, the macerator pump may not turn freely. Regular use of the system will reduce the chances of this occurring. If the system does require maintenance contact your dealer. Because your waste system is low-water consumption, there is special paper which must be used to prevent clogs.

NOTICE

The low-water consumption waste system requires the use of special paper to prevent clogs. The manufacturer has provided information regarding the type of paper that must be used. Never use residential tissue paper in your marine waste system.

REFER TO OWNER'S PACKET FOR COMPLETE INSTRUCTIONS AND WARRANTY INFORMATION.

Dockside Discharge

NOTICE

Dockside discharge is the preferred method of waste disposal.

The dockside discharge cover is located on the starboard transom deck. Access is gained by use of a special two-pin key that is included in the owner's packet. The dockside facility will have a connection to fit this vessel.

NOTICE

It is important that you close your macerator discharge seacock prior to using the dockside discharge function.

Air Conditioning (Option)

If equipped, the reverse-cycle air conditioning system consists of an A/C unit (8000 BTU), a seawater pump with seacock, strainer, and control unit so that the water pump is activated by demand when the AC unit comes on.

The cabin A/C unit is located in the mid berth and can be accessed through a starboard-side panel. Do not block the A/C unit vent or return air grill. Be careful not to damage the Freon lines running to the compressor.

The cabin A/C unit is controlled by a touchscreen controller keypad unit located on the forward port cabinet of the cabin. The keypad allows the operator to preset the temperature for the cabin. The air unit will activate automatically when the temperature of the cabin is not consistent with the preset temperature. When the A/C unit is activated, seawater is pumped into the system by way of a seacock and strainer, passes through the compressor cooling the condensing coils, and then flows overboard through the thru-hull drain.

The helm A/C is controlled by a second touchscreen controller keypad unit located in the overhead hardtop. The helm A/C unit is located under the helm seat and can be accessed through a door on the helm seat pedestal. Do not block the A/C unit vent or return air grill. Be careful not to damage the Freon lines running to the compressor.

Starting the AC System

- Make sure the seacock is open.
- Turn on the air conditioner breaker on the A/C main distribution panel.
- Set the keypad to the desired temperature.

REFER TO OWNER'S PACKET FOR COMPLETE INSTRUCTIONS AND WARRANTY INFORMATION.

Maintenance

The reusable air filter, located on the front of both A/C units, should be removed and cleaned periodically to assure clean air circulation and reduce stress on the units.

The seawater strainer, located in the aft bilge, should be inspected frequently and cleaned out if plugged. The strainer can be accessed by lifting the mechanical access hatch in the aft cockpit.

Air Conditioning System
Figure 3.18.1

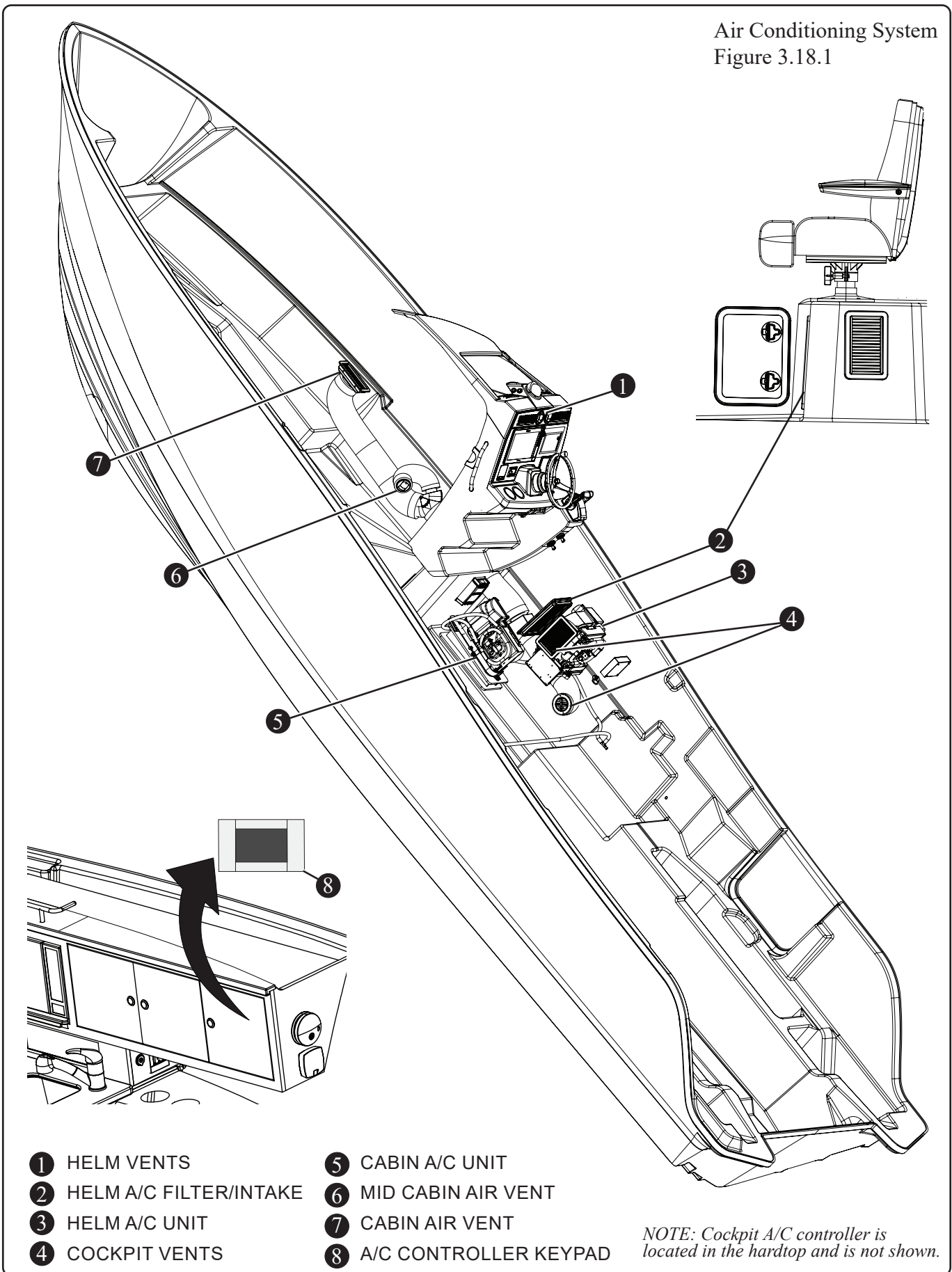

- | | |
|--------------------------|-------------------------|
| ① HELM VENTS | ⑤ CABIN A/C UNIT |
| ② HELM A/C FILTER/INTAKE | ⑥ MID CABIN AIR VENT |
| ③ HELM A/C UNIT | ⑦ CABIN AIR VENT |
| ④ COCKPIT VENTS | ⑧ A/C CONTROLLER KEYPAD |

NOTE: Cockpit A/C controller is located in the hardtop and is not shown.

Generator (option)

ATTENTION

Ensure generator seacock is open before starting. Close seacock when generator is not in use to prevent generator damage while underway.

Read and understand the information in the generator manufacturer's manual before operating the unit. This vessel's AC electrical system operates on 120V/60Hz or 220V/50Hz from the generator (if equipped) or shore power. The generator can be selected by using the slide selector switch on the AC distribution panel. The generator has a built in cooling pump which draws water through a seacock located in the mechanical access hatch. Water passes through a strainer before entering the engine cooling manifold.

WARNING

Carbon monoxide can cause severe nausea, fainting or death. The exhaust system must be leakproof and routinely inspected.

Fire can cause severe injury or death. Do not smoke or permit flames or sparks near fuels or the fuel system.

Explosive fuel vapors can cause severe injury or death. Use extreme care when handling, storing and using fuels.

Moving parts can cause severe injury or death. Operate the generator set only when all guards, screens and covers are in place.

Gas Generator (Option)

Figure 3.19.1

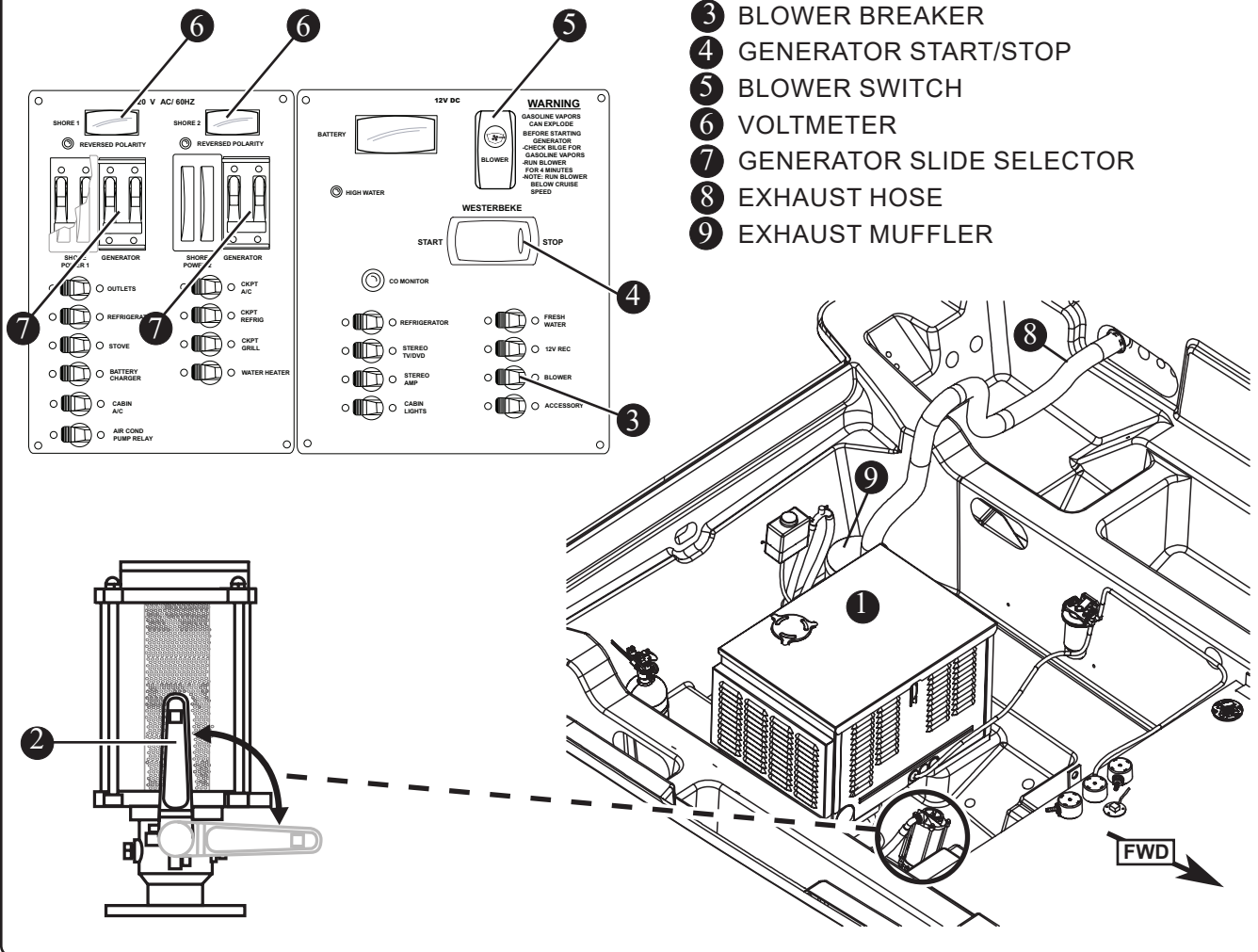

- 1 7.5KW GENERATOR
- 2 RAW WATER INTAKE SEACOCK W/ STRAINER
- 3 BLOWER BREAKER
- 4 GENERATOR START/STOP
- 5 BLOWER SWITCH
- 6 VOLTMETER
- 7 GENERATOR SLIDE SELECTOR
- 8 EXHAUST HOSE
- 9 EXHAUST MUFFLER

Fuel

The generator draws fuel from the main fuel tank and the fuel system is designed to run out of fuel with about 1/4 tank of fuel remaining, leaving a reserve of fuel for engine propulsion.

Do not run the generator set out of fuel because the fuel lines will draw in air and necessitate bleeding the system before restarting. The generator should be shut off before the fuel level reaches the 1/4 tank level. The exhaust from the generator passes through a high-efficiency, water-lift type, water-cooled muffler and is discharged by a flexible hose via a hull fitting. The generator has a housing that acts as a sound shield. It can be removed by pulling the latches located on the housing.

Starting the Generator

REFER TO OWNER'S PACKET FOR COMPLETE INSTRUCTIONS AND WARRANTY INFORMATION.

Start-up

- Refer to generator manual for pre-start checklist
- Operate generator blower for four minutes and manually check bilge for fuel or fuel vapor (see Figure 3.20.1). Also run blower when operating below cruising speed.
- Open generator seacock
- Generator breaker must be turned off
- Check for water in strainer
- Press *START* button until generator starts

Do not crank the generator for more than 20 seconds at a time. Allow for a 60-second cool down period between cranking attempts.

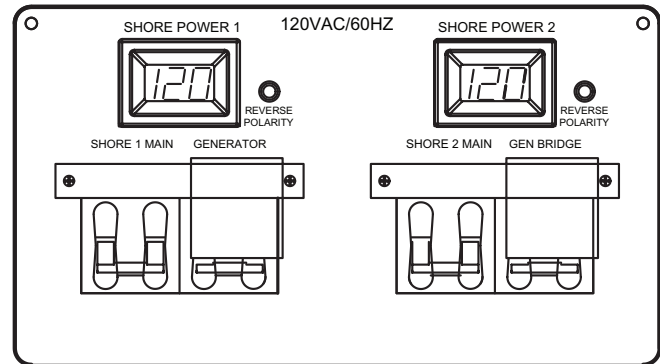

If the generator fails to start after the first attempt, close the seacock to prevent water from getting into the generator. Open the seacock when the start sequence is successful. If the unit fails to start after three attempts, contact an authorized dealer.

Stopping

- To stop generator press *STOP* button.
- Close seacock to prevent generator damage while underway.

Do not run the generator out of fuel because the fuel lines will draw in air and necessitate bleeding the system before restarting the unit. The operations manual included in the owners packet will have complete instructions on bleeding the fuel system should it be needed.

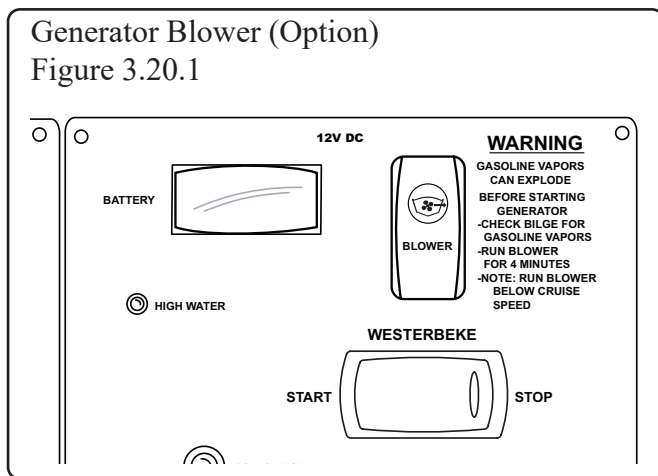

Generator Maintenance

WARNING

Accidental starting can cause severe injury or death. Disconnect the battery cables before working on the generator. Disconnect the negative, (-) cable first when removing and reconnect it last when replacing.

Maintenance work must be performed by appropriately skilled and suitably trained maintenance personnel familiar with generator set operation and service.

REFER TO OWNER'S PACKET FOR COMPLETE INSTRUCTIONS AND WARRANTY INFORMATION.

Operation in EU Member Countries

This generator set is specifically intended and approved for operation below the deck in the mechanical access hatch. Operation above the deck and/or outdoors would constitute a violation of European Union Directive 2000/14/EC noise emission standard.

Fire Suppression System (Option)

NOTICE

The fire extinguishant contained in this unit is chlorotetrafluorathane. None of the components in this material is listed by major health associations as a carcinogen. Toxic by-products are produced when this agent extinguishes fire. Avoid breathing these fumes.

This vessel has a USCG approved automatic fire suppression system that is installed with the generator option. The automatic fire suppression system is located in the starboard aft corner of the mechanical access hatch. The system will activate when the temperature in the enclosed area reaches 165°F (74°C).

DANGER

Do not handle the actuator. The fire suppression system is under pressure (195 psi). Accidental discharge may result in death or serious injury.

DANGER

Inhalation of high concentrates of the contents of the fire suppression tank may cause sudden death without warning.

Skin contact will require flushing of the area with water for at least 15 minutes. Seek immediate medical assistance.

When the fire suppression system is activated, there will be a loud, audible bang, followed by a rushing air sound. Once activated the engine and blower will shut down automatically.

In the Event of Discharge:

- Shut down all electrical systems, engines and extinguish all smoking materials.
- Allow the agent to soak the compartment for at least 15 minutes.
- Do not open the mechanical access hatch.
- Do not breathe the fumes or vapors caused by fire as they are hazardous and toxic.
- When opening the hatch, have a portable fire extinguisher at hand and ready for use.
- High concentrations of the agent may cause death without warning. The vapor reduces available oxygen for breathing.
- If possible, allow the compartment's vapor to dissipate before opening the hatch.

CAUTION

Never attempt to modify or disassemble any components of this system. If the system has been discharged, have a qualified technician replace it.

Manual Override System

The automatic fire extinguisher can be activated manually by pulling the manual fire extinguisher handle located behind the helm seat (see Figure 3.22.1). Early detection and use of the manual override system reduces fire damage by eliminating the time necessary for heat in the bilge to rise sufficiently to activate the automatic system. To operate:

1. Pull pin securing the handle.
2. Pull red *FIRE* handle quickly and briskly.

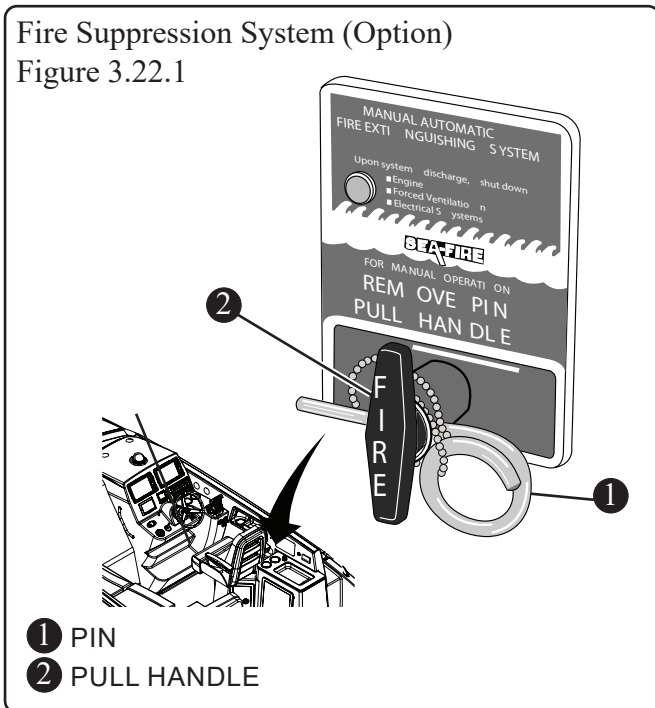

REFER TO OWNER'S PACKET FOR COMPLETE INSTRUCTIONS AND WARRANTY INFORMATION.

Galley

The standard galley in this vessel includes a galley sink with faucet and cutting board, Corian solid surface countertop, stove, microwave, refrigerator, and trash receptacle under cabin steps.

WARNING

Burn/scalding and/or fire hazard

- Do not use the stove while underway.
- Do not allow clothing or other flammable material to come in contact with stove or surrounding area.

REFER TO OWNER'S PACKET FOR COMPLETE INSTRUCTIONS AND WARRANTY INFORMATION.

Cruising Package (option)

The optional cruising package includes an electric, single-burner stove, dockside hook-up for water system, and a water heater to provide fresh hot water to the galley sink.

Cockpit Refrigerator/Freezer (option)

The AC/DC refrigerator/freezer is located on the front of the prep station. The *REFRIG* breaker located in the galley cabinets must be *ON* for the refrigerator/freezer to function. If not connected to shore power or optional generator, the refrigerator/freezer will default to battery power.

NOTICE

To avoid draining the batteries, the refrigerator and/or battery switch must be turned off.

REFER TO THE MANUFACTURER'S MANUAL IN YOUR OWNER'S PACKET FOR COMPLETE INSTRUCTIONS AND WARRANTY.

Foldaway Port Seat (option)

When the foldaway port seat is not in use it is folded under the gunwale. To use the seat, unhook two gunwale bungees and rotate the gunwale cushion up; fold down the seat.

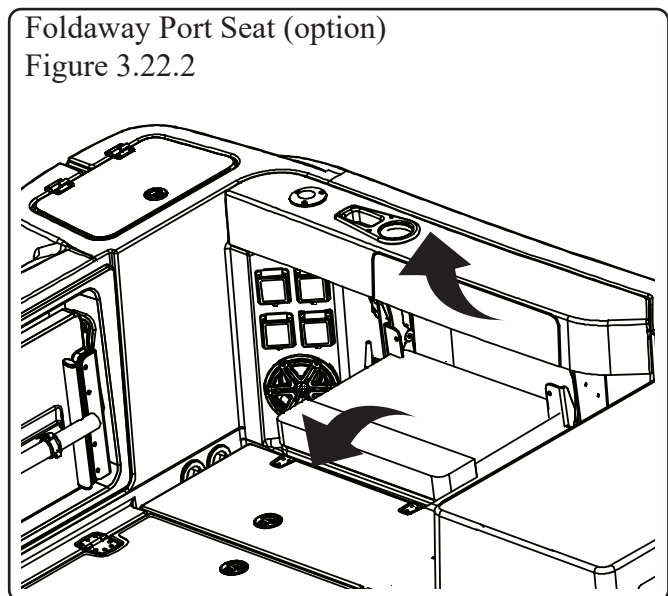

Convertible Lounge Seating

The convertible port seat and lounge combination offers multiple set-up configurations as shown in Figure 3.23.1 and Figure 3.24.1.

Conversion of the port seat exposes the lounge table, thus creating a dining or activity area. Or, by inserting the removable cushions on the unfolded table, the area becomes a lounge.

Before attempting to raise or lower the table, first make sure it is folded in half. To raise the table, loosen the two pedestal locks to unlock the table; the gas actuated pedestal rises with some assistance. Tighten the pedestal locks to lock the table at the desired height. To lower the table, release the pedestal locks and push down firmly in the center of the table; tighten the pedestal locks to lock the table in place.

Convertible Seating
Figure 3.23.1

- ① PORT SEAT BACK
- ② PORT-SEAT LEVER
- ③ LOUNGE SEAT BACK
- ④ LOUNGE GRAB RAIL
- ⑤ TABLE-SUPPORT LEDGE
- ⑥ LOUNGE TABLE
- ⑦ TABLE-TOP SUPPORTS
- ⑧ REMOVABLE CUSHION
- ⑨ FOOTREST GRAB RAIL
- ⑩ PEDESTAL LOCK

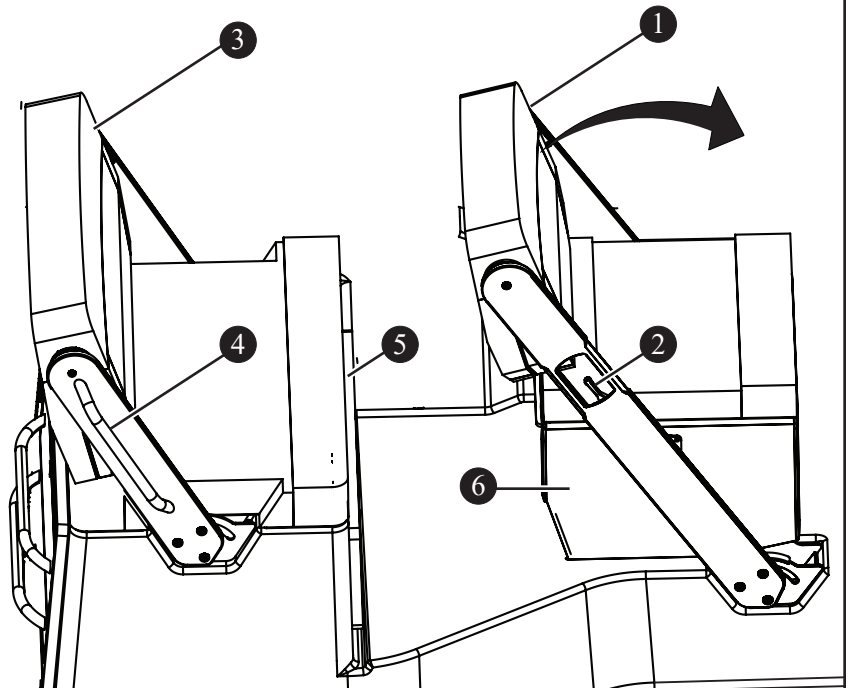

1. Start Position

Slide port seat lever/seat back forward until an audible click is heard; this exposes the table.

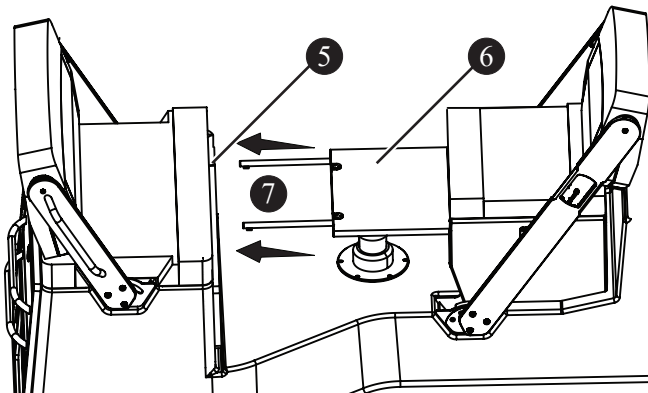

2. Support Table

From under table, fully extend table-top supports.

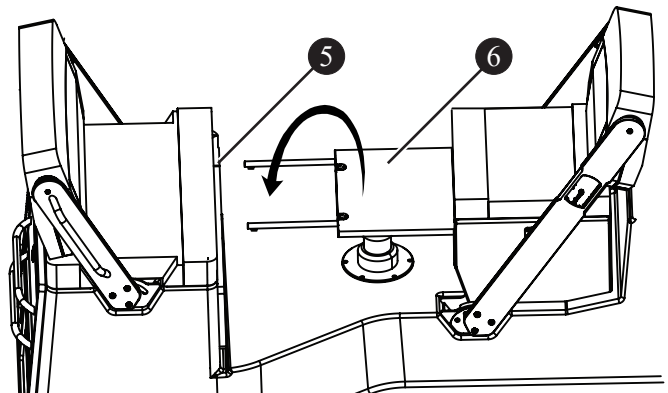

3. Unfold Table

Unfold table to rest on table-support ledge.

Convertible Lounge Seating (continued)

Figure 3.24.1

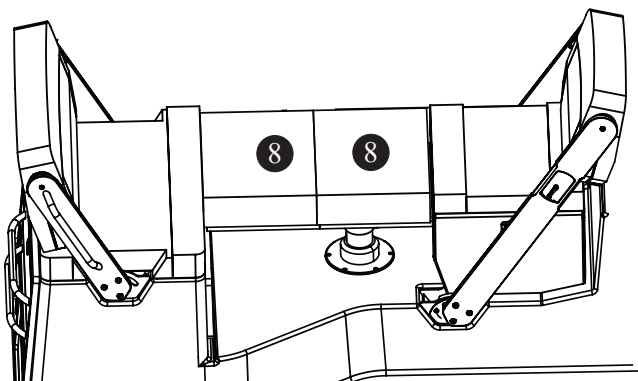

4. Place Cushions

Mate the Velcro sides of the removable cushions together and place onto unfolded table.

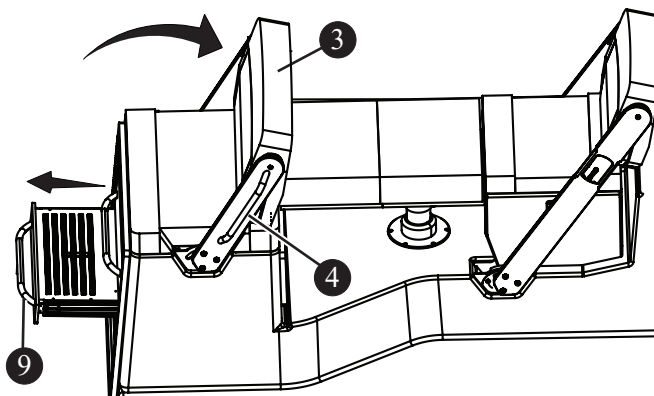

5. Rear-Facing Lounge w/ Footrest

Pull the lounge grab rail forward to move the lounge seat back to a rear-facing position. Pull out the footrest by using the footrest-drawer grab rail.

NOTICE

- Raise/lower table in unfolded position only.
- Keep table stowed when underway.

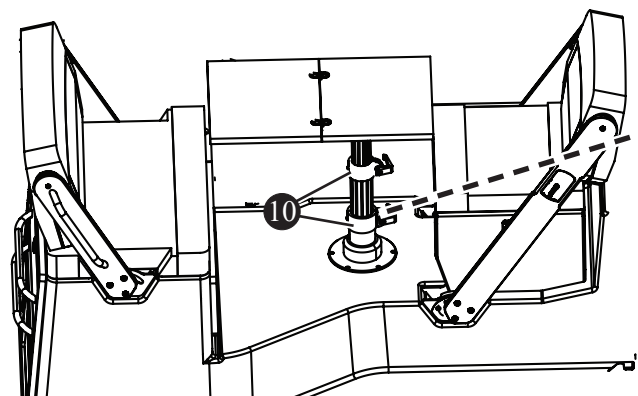

6. Raise/lower Table

With table in the folded position (see step 2), unlock pedestal locks and pull up to raise table to desired height. Relock table locks securely, slide out table supports, and unfold table.

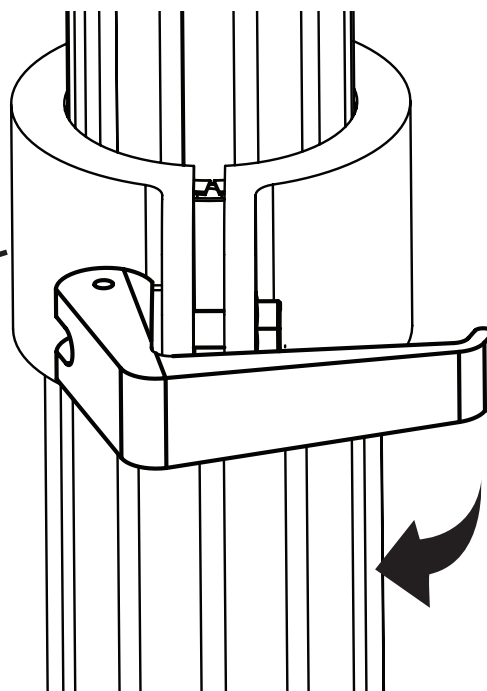

Dive Door

This vessel includes a starboard-side door for ease of transition to and from the water or dock (see Figure 3.25.1). The door has a swivel grab handle to assist persons entering or exiting the water. To use grab handle, lift up and swivel into place.

The stainless-steel deck bracket accommodates a removable ladder which is stowed in the base of the bench seat when not in use.

Dive Door
Figure 3.25.1

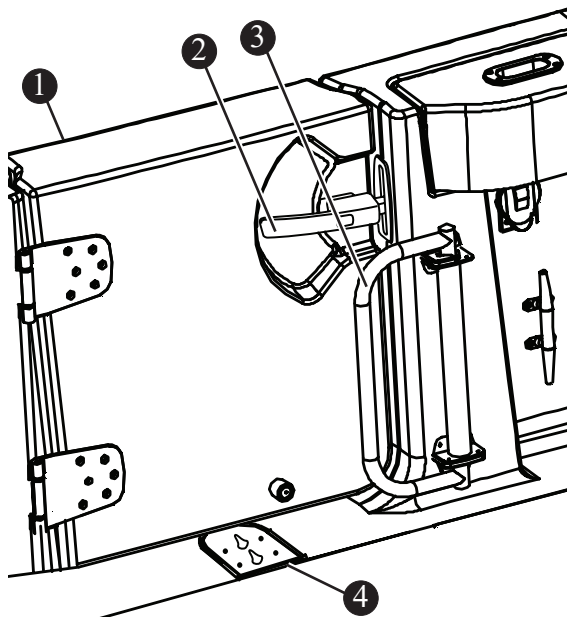

- ① DIVE DOOR
- ② DOOR LATCH
- ③ SWIVEL GRAB HANDLE
- ④ LADDER BRACKET

⚠ DANGER

Ensure that door is closed and securely latched when boat is underway.

Dive Ladder

⚠ DANGER

The dive ladder should never be deployed when boat is in motion or engines are running. To avoid risk of injury or death, shut off engines when using dive door to enter or exit the water.

Dive ladder installation:

- Remove ladder from its stowed position on the base of the bench seat.
- Rotate brace at top of ladder so it's perpendicular to the ladder shaft.
- Insert two pegs on brace into deck bracket.
- Secure ladder into place by pushing brace outboard until it seats firmly into bracket and locking pin snaps into place.

Dive Ladder Installation
Figure 3.25.2

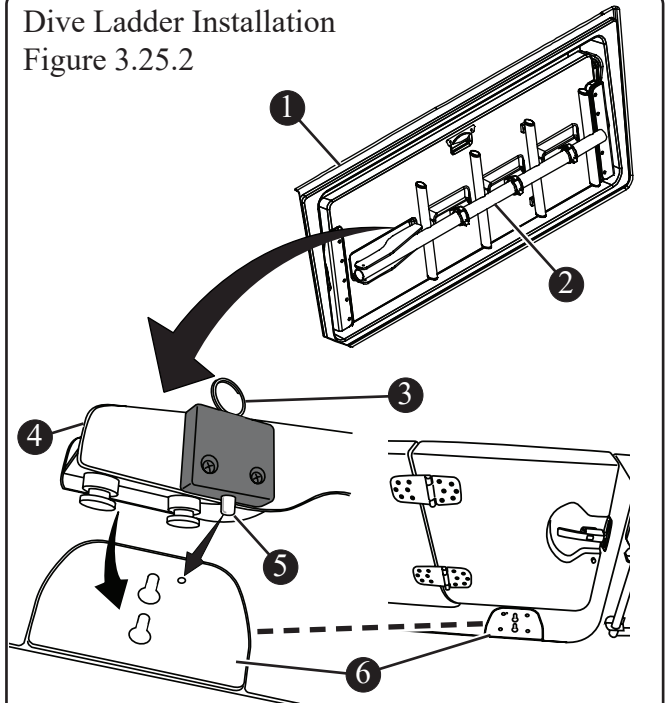

- ① BENCH SEAT
- ② DIVE LADDER
- ③ LOCKING PIN RELEASE RING
- ④ DIVE LADDER BRACE
- ⑤ LOCKING PIN
- ⑥ LADDER BRACKET

Dive ladder uninstall:

- Pull up and hold the locking pin release ring.
- Pull dive ladder brace inboard and lift up and out of the deck bracket.
- Using bungee straps, secure ladder into place on the base of the bench seat.

Reboarding Ladder

The reboarding ladder is located under the swim ladder cover on the aft starboard deck of the boat (see Figure 3.26.1). The ladder can be accessed without the cover raised. To deploy the reboarding ladder:

- Release cover's rubber locking strap
- Pull ladder out
- Rotate ladder unit downward
- Extend ladder rungs

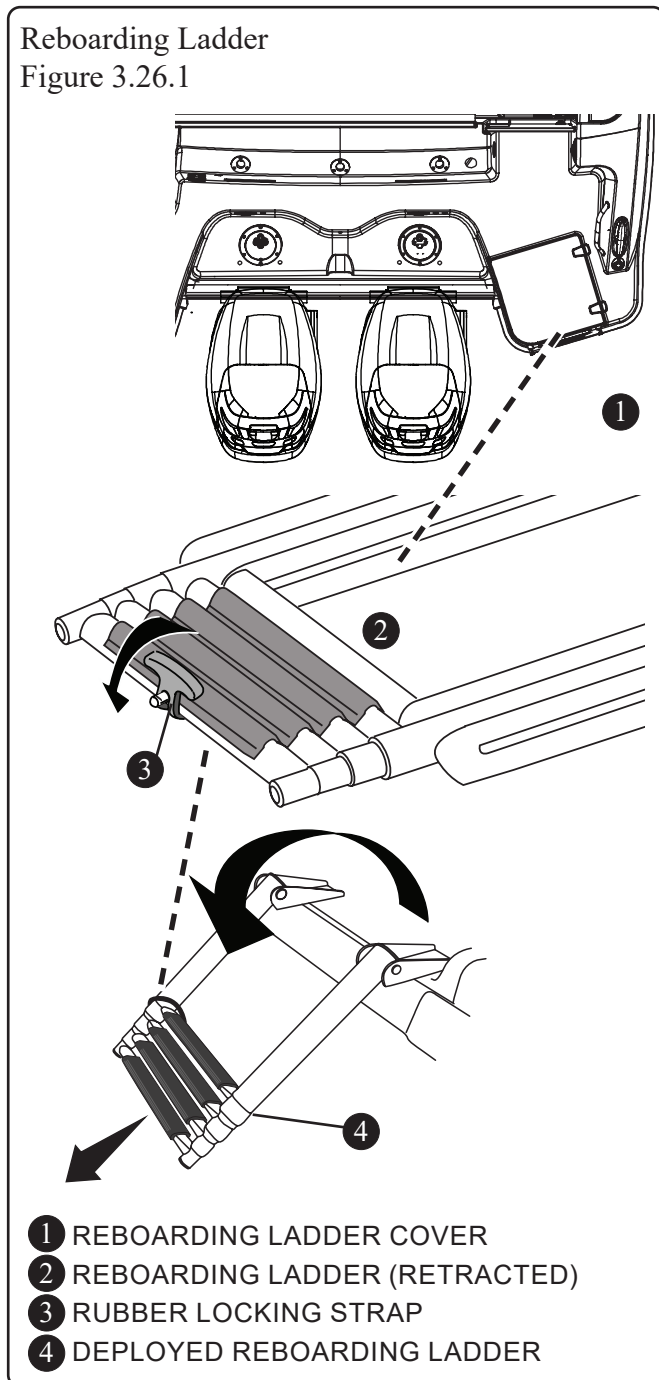

Entertainment System

The entertainment system consists of a stereo/radio with CD player, waterproof speakers, remote control pad and MP3 input. The stereo/CD player is in the forward upper cabinet of the galley. The stereo remote is located on the control station starboard of the helm. To use:

- Connect standard 3.5 mm (1/8") mini stereo cable (not included) between MP3 player and the MP3 input; turn stereo on.
- Press CD button at the top of the stereo unit to access MP3 source; turn MP3 player on
- Control volume and menu functions from MP3 unit, the remote or the stereo.

TV (Option)

If boat is equipped with the optional entertainment package, there is a flat screen TV in the cabin.

CD/DVD

The CD/DVD player has a hand-held remote for both TV and DVD operation.

Cockpit and Cabin Speaker Zones

Zone 1: Hardtop speakers

Zone 2: Cabin

Zone 3: Subwoofer (option)

Operation

- Press the hand-held remote *Menu* button to switch to the sound adjustment display.
- Use the *Rotary Encoder* to select the desired zones and select *ON*.

NOTE: *Zone 1* cannot be turned *OFF*.

- Select *Zone 1* then *Link Zone 1 + 2*. Select *ON* to activate. Linking zone one and two allows volume control over both zones simultaneously. The zone set up for zone one and two can be configured separately when in this mode.
- Select *Volume Limit* to set the desired output volume for each individual zone.
- Rotate the *Rotary Encoder* control clockwise to increase volume and counter clockwise to decrease volume.

Gyroscopic Stabilizer (Option)

The gyroscopic stabilizer, located aft of the cockpit (see Figure 3.27.1), reduces boat roll motion independent of boat speed, thus making it easier to move around the vessel - and help prevent motion sickness. The remote display is located in the hardtop (see Figure 3.27.2) but this information can also be accessed at the helm. Start the generator to use the gyroscopic stabilizer.

REFER TO OWNER'S PACKET FOR COMPLETE INSTRUCTIONS AND WARRANTY INFORMATION.

WARNING

Gyroscopic stabilizer cover prevents personnel or equipment from contacting unit while in operation; keep covered. Do not step on or place anything on cover. If contact is necessary while unit's flywheel is spinning, lock control at remote display to stop gyroscopic stabilizer from precessing (tilting). Maintenance should not be attempted unless gyroscopic stabilizer is locked and the flywheel has stopped spinning.

Gyroscopic Stabilizer Display (Option)
Figure 3.27.2

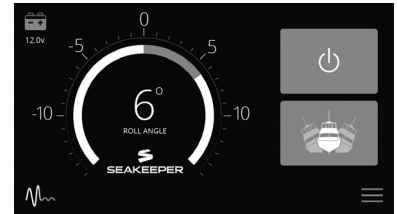

- Spool-up Time to Rated Speed - 50 minutes
- Spool-up Time to Stabilization - 35 minutes
- Full speed to zero RPM - approximately 2 hours

Gyroscopic Stabilizer (Option)
Figure 3.27.1

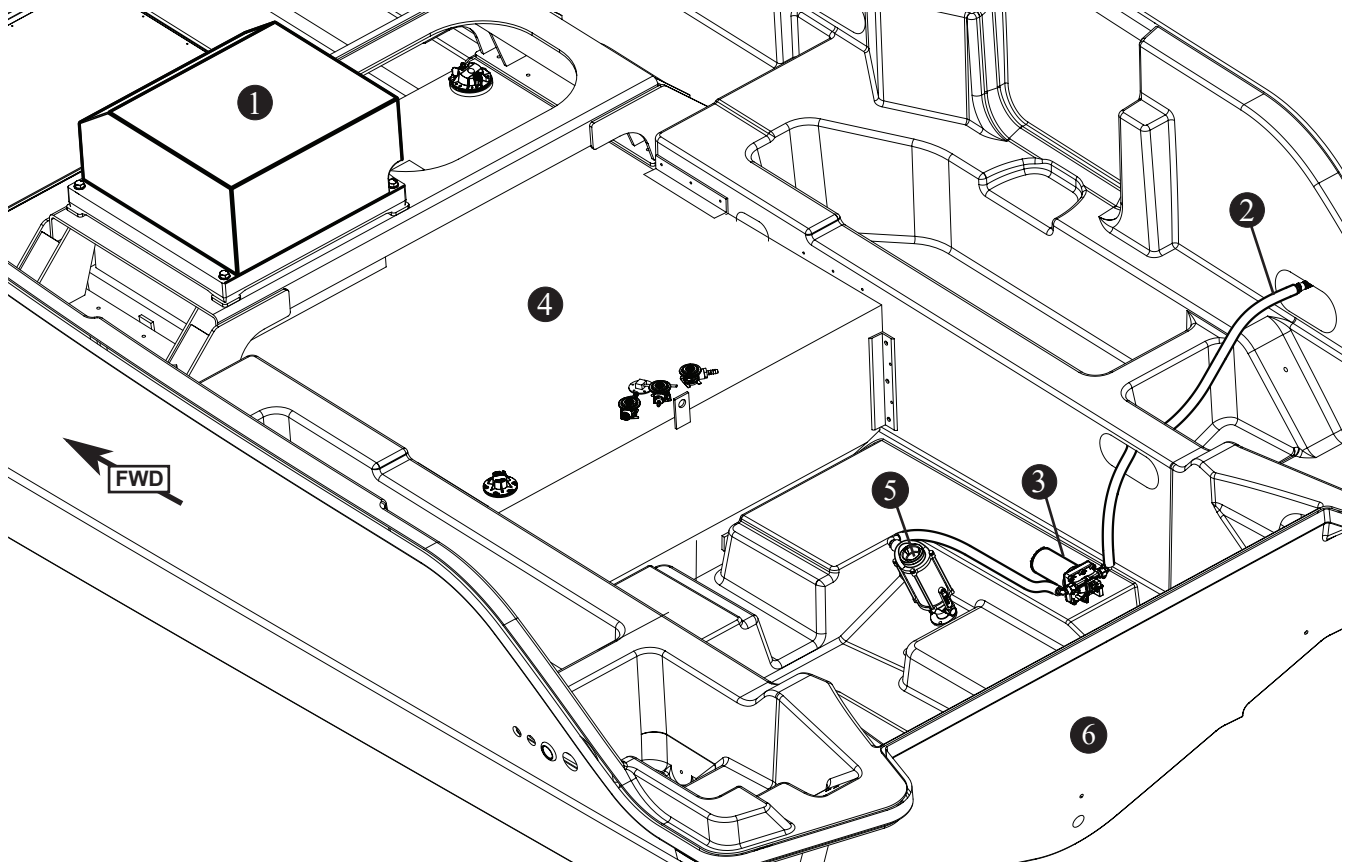

- 1 GYROSCOPIC STABILIZER
- 2 TO THRU HULL OUTLET
- 3 PUMP
- 4 FUEL TANK
- 5 RAW WATER SEACOCK
- 6 TRANSOM

Cockpit Drawers and Storage

The cockpit drawer options include a pull-out footrest, pull-out grill, and several other drawer/door configurations (see Figure 3.28.1 - Figure 3.28.3)

Pull-out Footrest

The pull-out footrest provides a place for occupants of the convertible lounge to place their feet when the seat is in the rear-facing position. To open:

- Pull out drawer handle.

NOTE: Use the step to ascend up to the footrest.

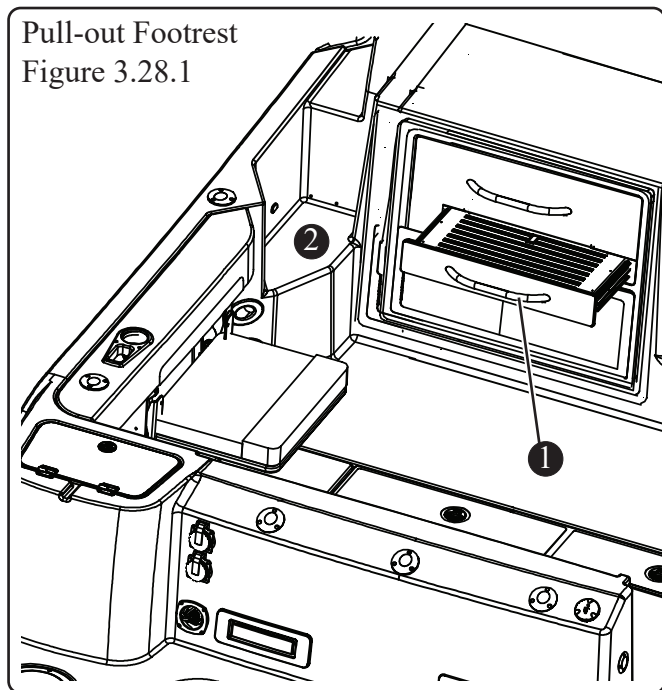

- ① FOOTREST DRAWER HANDLE
- ② STEP
- ③ GRILL DRAWER LATCH
- ④ GRILL DRAWER HANDLE
- ⑤ STORAGE AREAS
- ⑥ GRILL LID

Pull-out Grill

The pull-out grill provides onboard grilling. To open:

- Pull grill latch while pulling drawer handle
- Lift grill lid to vertical position
- Lower grill lid down until it seats firmly
- To close grill, pull latch and push drawer handle in

NOTICE

Keep grill closed while boat is underway.

REFER TO THE OWNER'S PACKET FOR COMPLETE INSTRUCTIONS AND WARRANTY INFORMATION.

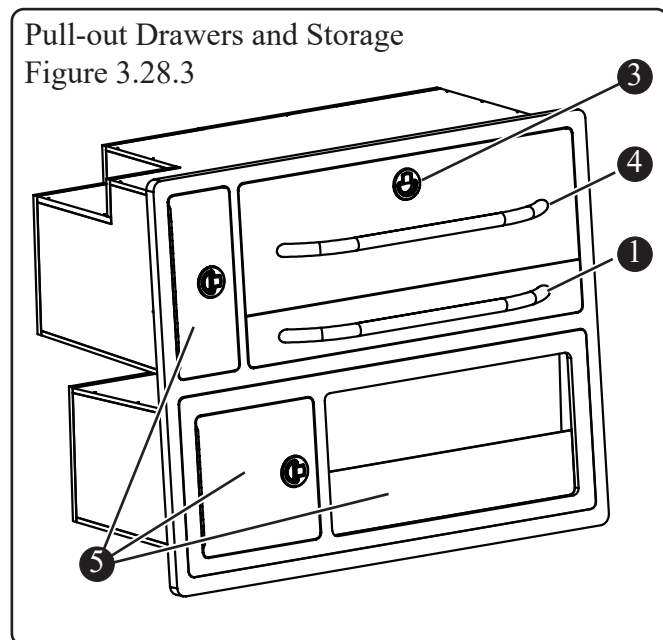
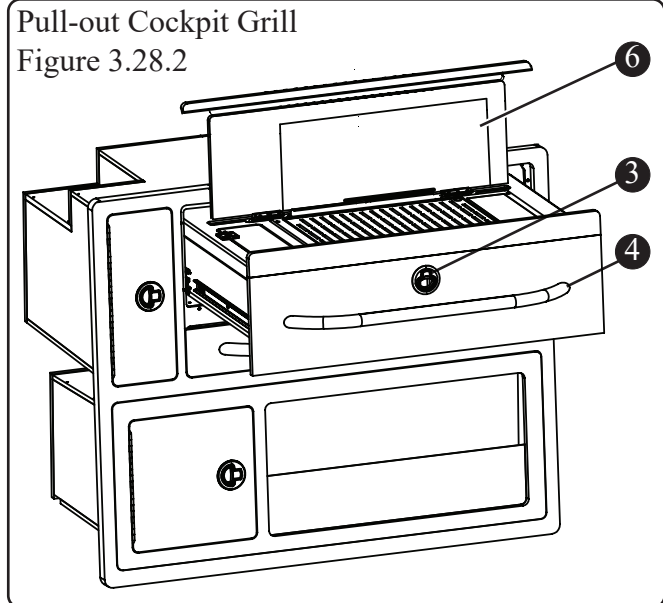

Anchoring

WARNING

SWAMPING HAZARD - Anchor from the bow if using one anchor. A small current can make a stern-anchored boat unsteady. A heavy current can drag a stern anchored boat underwater.

COLLISION HAZARD - Anchor only in areas where the boat will not disrupt other boats. Do not anchor in a channel or tie up to navigational aids as it is both dangerous and illegal.

WARNING

Keep hands, feet, hair and loose clothing clear of moving parts (anchor, rode, etc.). Entanglement may cause severe bodily injury (i.e. lose of fingers or toes).

CAUTION

Be careful trailing lines do not foul the .

CAUTION

To avoid property damage, engage gypsy lock and ensure anchor is secured with lanyard before getting underway.

NOTICE

Before using the anchor be sure the anchor line is securely attached to the eye in the bottom of the anchor locker and to the anchor itself.

NOTICE

Turn on the anchor light when at anchor or drifting (not under power) at night or in low visibility.

REFER TO THE OWNER'S PACKET FOR COMPLETE INSTRUCTIONS AND WARRANTY INFORMATION.

Anchoring Operation

To anchor, turn bow into the wind or current and put the engines in neutral. When the boat comes to a stop, lower the anchor from the bow (see Figure 3.30.1).

Proper anchoring requires knowledge of rode and scope and understanding the relationship between rode, scope and anchor performance.

Rode: The rode is the line connecting the anchor to the boat. Nylon line is ideal because it is light, strong and stretches, it also can be stored wet and is easy to handle. Add a length of chain between the anchor and the nylon line to help set the anchor more easily.

Scope: The scope is technically defined as the ratio of rode length to the vertical distance from the bow to the sea floor. Scope also depends on the type of anchor, tides, winds, sea conditions and type of sea floor the anchor is in. To determine how much rode to use when anchoring, use this common formula:

Rode length = (bow height + water depth) × scope

The minimum is 5:1 for calm conditions; normal is 7:1, and severe conditions may require 10:1.

Example:

$$\text{Rode length} = (3 \text{ feet} + 10 \text{ feet}) \times 7^*$$

$$\text{Rode length} = 13 \text{ feet} \times 7^*$$

$$\text{Rode length} = 91 \text{ feet}$$

* Scope may range from 5 to 10 or more. However, less than 5, the anchor will break out too easily.

Considerations

- Wind and sea conditions can affect the boat.
- Because the boat is not moving through the water, there is no control.
- Be sure that the anchor will hold under all circumstances if you are leaving the boat.
- Understand the principles of rode and scope and their effect on anchor performance.

Proper Anchoring
Figure 3.30.1

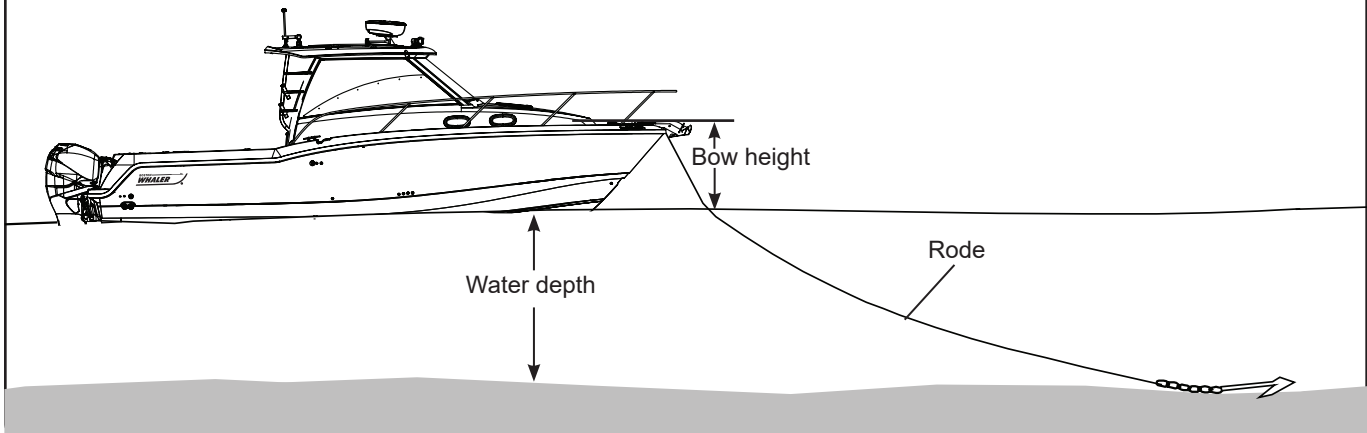

$$\text{Rode length} = (\text{bow height} + \text{water depth}) \times \text{scope}$$

Because there are a variety of anchors, for a variety of uses, discuss the types of anchors with your dealer to find the right anchor for this vessel.

Lowering the Anchor

- Be sure there is adequate rode.
- Secure rode to both the anchor and the boat.
- Stop completely before lowering the anchor.
- Keep feet clear of lines.

NOTE: If using the optional windlass, refer to the windlass operator's manual for anchoring instructions

Setting the Anchor

There is no best way to set an anchor. Experiment to see how it performs. One method is to turn the rode around a bitt or a cleat and slowly pay out as the boat backs from the anchor site. When the proper scope has been reached snub the rode quickly, causing the anchor to dig in to the sea bottom.

- Reverse the engine slowly to drive the anchor in and to prevent it from dragging
- Secure the rode to a bitt or cleat

Weighing the Anchor

To weigh or retrieve the anchor, start the boat and run slowly up to the anchor, taking up the rode as you go. The anchor will usually break out when the rode becomes vertical. Coil lines to let them dry before stowing. The bow storage compartment located in the starboard bow should be used to stow the anchor line.

Anchor Lanyard

Do not depend on the windlass to hold the anchor in place. Always secure the anchor with the anchor lanyard, a line attached to the anchor eye and fastened to the bow pulpit cleat when the anchor is stowed and the boat is underway (see Figure 3.31.1).

Anchor and Windlass
Figure 3.31.1

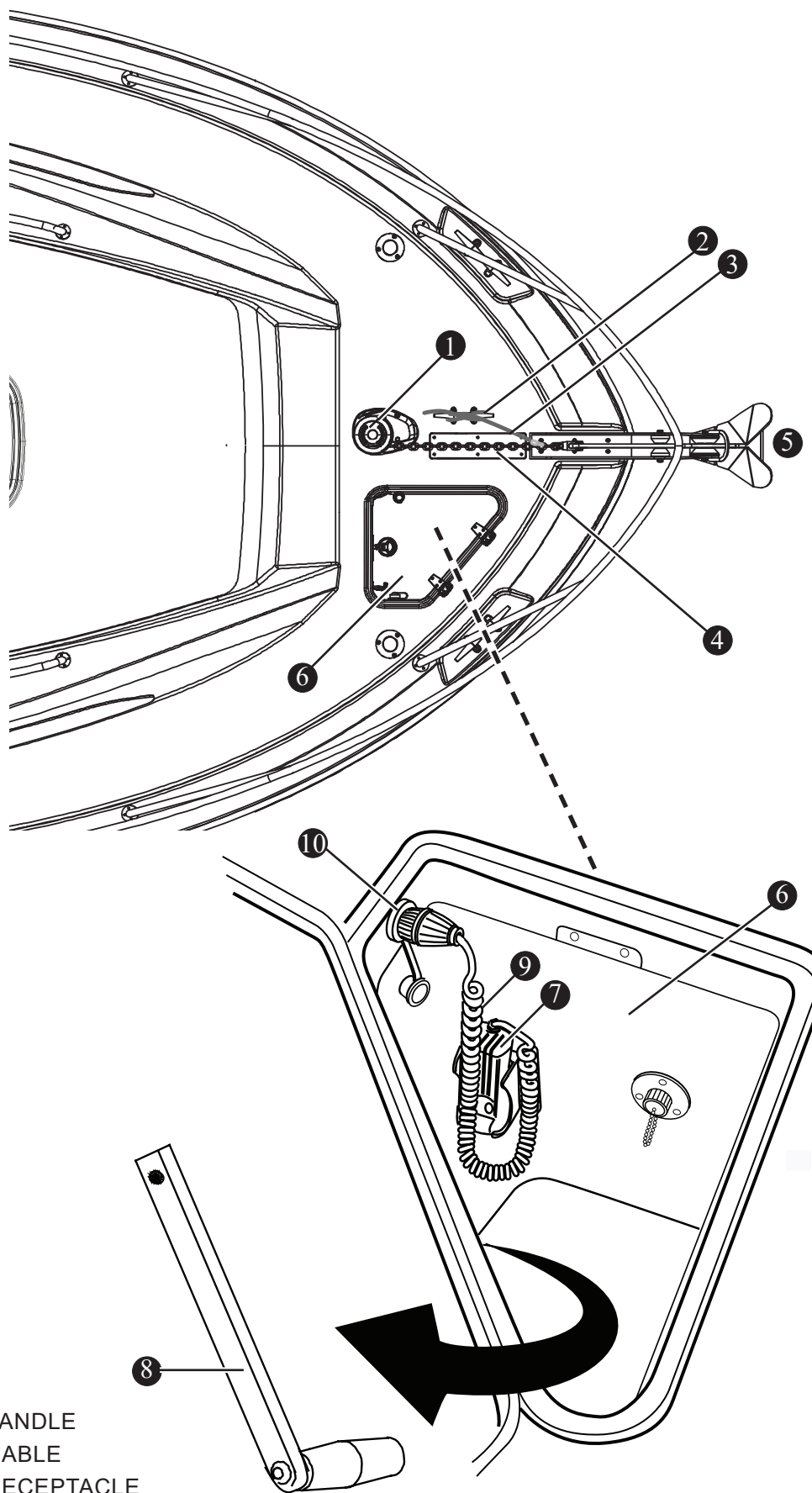

- ① WINDLASS
- ② CLEAT
- ③ ANCHOR LANYARD
- ④ CHAIN RODE
- ⑤ ANCHOR
- ⑥ ANCHOR LOCKER
- ⑦ WINDLASS REMOTE
- ⑧ WINDLASS MANUAL HANDLE
- ⑨ WINDLASS REMOTE CABLE
- ⑩ WINDLASS REMOTE RECEPTACLE

Anchor Windlass

NOTICE

Be sure to read and fully understand the anchor windlass instructions included in the owner's packet before operating the anchor windlass.

The anchor windlass located at the bow of this vessel facilitates the anchoring of this vessel by raising and lowering the anchor. The windlass can be operated from the helm, from the bow with remote control, or manually.

NOTE: To operate the windlass from the helm and with the use of the remote, the windless breaker on the battery switch panel must be turned on.

Helm Operation

The anchor windlass is controlled at the helm by two switches on the helm switch panel (see Figure 3.32.1). The *Windlass* switch powers the windlass on and off. The *Up/Down* switch is a momentary type switch, which means that there must be constant pressure applied to operate the anchor windlass and raise or lower the anchor.

Lowering the Anchor

Pushing the top part of the *Up/Down* switch powers the anchor windlass down. Make certain that the anchor lanyard is detached from the chain and is clear of any moving parts of the anchor windlass.

Raising the Anchor

Pushing the lower part of the switch *Up/Down* switch powers the anchor windlass up. Once the anchor and rode is secure in the up position, the anchor safety lanyard can be re-attached to the rode.

Manual Windlass

In the event that there is a loss of power to the windlass the anchor can be raised and/or lowered manually by using the manual handle located in the anchor locker (see Figure 3.30.1). To use, insert handle into windlass' center socket for manual deployment of the anchor. Turning the handle counterclockwise lowers the anchor, while turning it clockwise raises it. Be sure to attach the safety lanyard when the anchor is stowed in the anchor well.

Windlass Switches

Figure 3.32.1

- ① POWER SWITCH
- ② UP/DOWN SWITCH

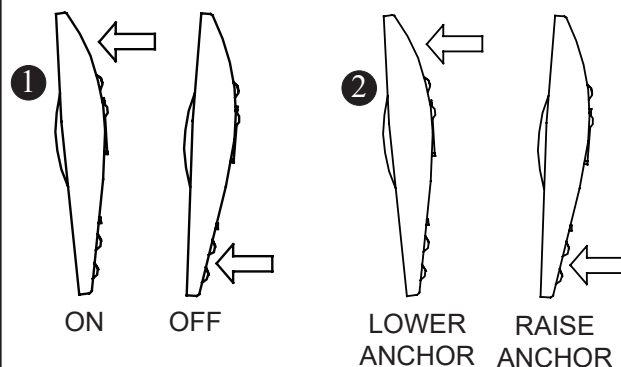
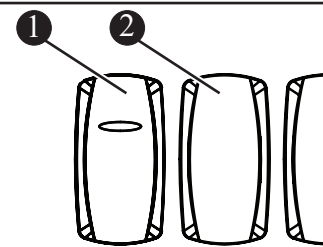

Operating the Windlass With Remote

⚠ DANGER

Use the anchor windlass switch on the helm when possible. Use care when operating the anchor windlass with the hand-held remote.

NOTICE

Before operating the windlass be sure that the safety lanyard is removed from the anchor chain and is clear of the rode as it plays out or is retrieved.

The anchor windlass can be operated from the bow with the use of the windlass remote which is stowed in the anchor locker (see Figure 3.31.1). To use:

- If not already plugged in, plug power cable into power receptacle in the anchor locker.
- Turn the forward portion of the plug clockwise to lock.
- To raise the anchor, press and hold on the *UP* button on the remote.
- To lower the anchor, press and hold on the *DOWN* button on the remote.

If there is a loss of power to the windlass, check the windlass circuit breaker located on the battery switch breaker panel. If the breaker is tripped, reset the breaker by pushing the lever up. If the breaker continues to trip, have the anchor windlass system checked by a qualified marine electrician.

Manual Windlass Operation
Figure 3.33.1

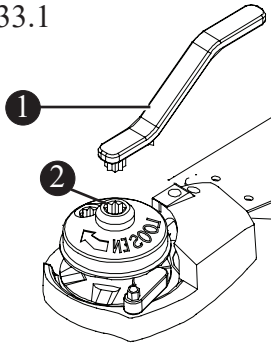

- ① MANUAL HANDLE
- ② CENTER SOCKET

Spotlight (option)

If equipped, the optional spotlight is mounted forward on the hardtop (see Figure 3.33.2).

Spotlight (option)
Figure 3.33.2

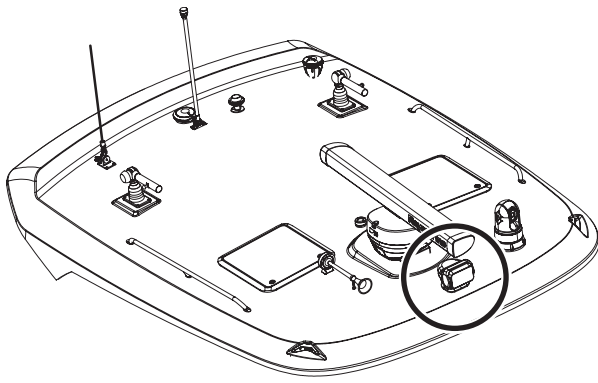

Operation

The two-speed spotlight is controlled by a remote toggle located at the helm (see Figure 3.33.3).

- Turn unit on by depressing power button
- Use toggle to aim spotlight
- Adjust the speed of the spotlight's rotation by depressing either the turtle (slow) button or the rabbit (rapid) button

Spotlight Controls (option)
Figure 3.33.3

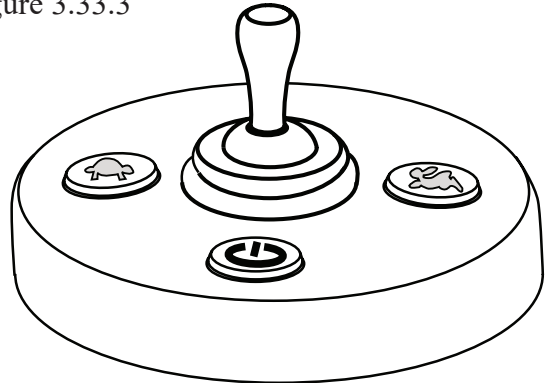

Bow Thruster (option)

! WARNING

Be sure to thoroughly understand bow thruster operation and safety requirements before using. Do not operate in close proximity to swimmers, as a powerful suction is created when in use.

If equipped, the electrically-driven bow thruster gives the operator extra maneuverability of the bow when docking or maneuvering the vessel in narrow channels or where space is at a premium. Boston Whaler uses a patent-pending design for installation of the bow thruster. The bow thruster motor can be accessed by lifting the cabin access hatch in the floor, forward of the table.

The battery switch is located port of the battery bank and can be accessed by lifting the mechanical access hatch. The bow thruster joystick (see Figure 3.34.1), located in the helm console, is used to operate the thruster and maneuver the bow of the boat.

▲ DANGER

Operating bow thruster out of water is very dangerous, even for a few seconds. The motor will overspeed by 300 percent, damaging the unit. In addition, the propeller will cause serious damage or injury to whatever comes in contact with it. This action voids the warranty.

⚠ CAUTION

Do not move the joystick port to starboard in quick succession as this could damage motor.

NOTICE

Refer to the bow thruster manufacturer's instructions in the owner's packet for bow thruster battery requirements.

Operation

- Turn battery switch to *ON* position.
- Depress power button (see Figure 3.34.1) for one second.
- Shift in desired direction (see Figure 3.34.2).
- When desired movement has been achieved return joystick to center position.

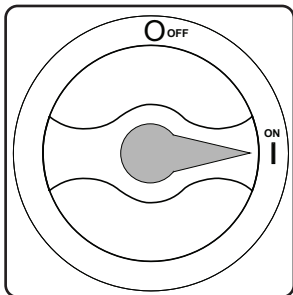

NOTE: The bow thruster motor is equipped with an internal, thermally-activated breaker to protect the motor from overheating. If the thermal breaker trips, power to controls is disabled. Allow the unit to cool down before continuing operation.

Bow Thruster Joystick
Figure 3.34.1

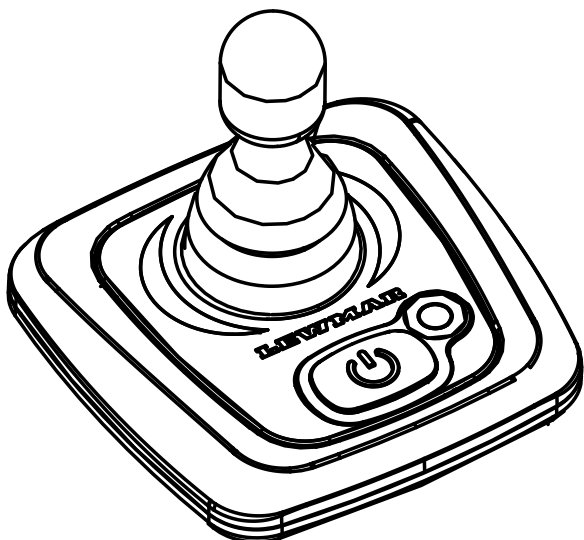

NOTICE

If bow thruster is in constant operation for three minutes it will power down and the panel will deactivate.

The system is designed to automatically power down after 20 minutes of no operation.

Bow Thruster Movement
Figure 3.34.2

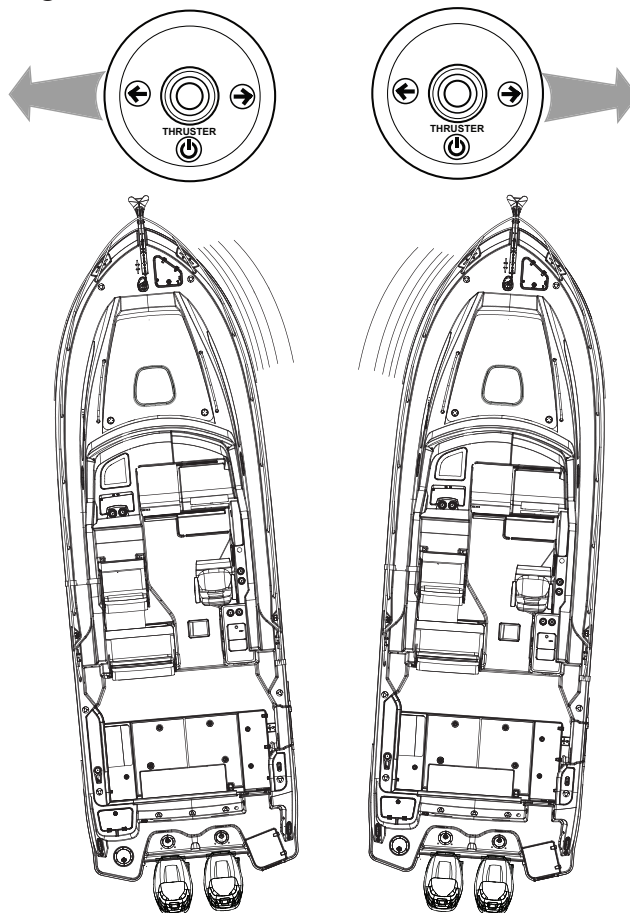

THIS PAGE INTENTIONALLY LEFT BLANK

Electrical

DC Electrical

This vessel's electrical system is powered by a series of batteries. The batteries are charged when the engines are running, by the generator or can be charged by shore power when the engines and generator are off.

A battery charger, located on the starboard wall of the bilge (shown later in this chapter), facilitates the charging of the batteries when using shore power. If this vessel has the optional gyroscopic stabilizer, an additional battery charger can be found under the prep station. See chapter 3, *Systems Overview and Operation* for shore power operation.

The electrical system utilizes selector switches to control the delivery of power to the following:

- Engine ignition
- Engine tilt trim system
- Helm switch panel and helm instrument panel
- Lighting/navigation systems
- Livewell system
- Add-on accessories and electronics

Batteries

⚠ DANGER

Batteries contain sulfuric acid which can cause serious injury. Avoid contact with skin, eyes and clothing. If contact occurs, immediately flush affected area with large quantities of water and obtain medical assistance.

NOTICE

Always store the batteries in the battery trays. Use the retaining lid and nylon lock nuts to keep the batteries secure while underway.

REFER TO ENGINE MANUFACTURER'S MANUAL IN OWNER'S PACKET FOR COMPLETE INSTRUCTIONS AND WARRANTY INFORMATION.

The following table is for reference purposes only. Use only AGM batteries with Verado engines.

Application	Group	Volts	MCA*	RC 25	Qty.**
USA (SAE)	31	12	800	135 min	4

*Marine cranking amps

**Gyroscopic stabilizer option includes additional fifth battery

Application	Group	Volts	CCA*	Reserve	Qty.**
Int'l (EN)	31	12	975	65Ah	4

*Cold Cranking Amps

**Gyroscopic stabilizer option includes additional fifth battery

NOTICE

Ensure batteries meet Mercury's AGM/CCA requirements.

Battery Trays

Four battery trays are located in the bilge. One can be found under the cockpit prep station if the gyro option is included. Batteries should always be secured in the battery trays provided and secured in place by the retaining brackets. The trays ensure that while underway the batteries do not move around, thus causing damage to components fitted in the same area.

The batteries can be removed from the trays by first removing the negative wires followed by the positive wires. Then remove the retaining lid on the battery tray.

Standard Battery Location Label

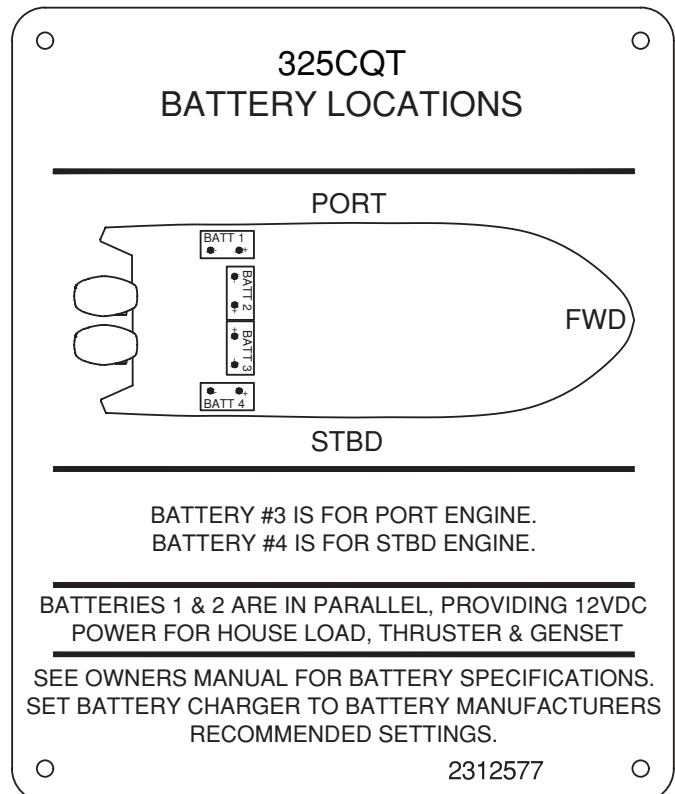

Gyroscopic Stabilizer Battery Location Label (option)

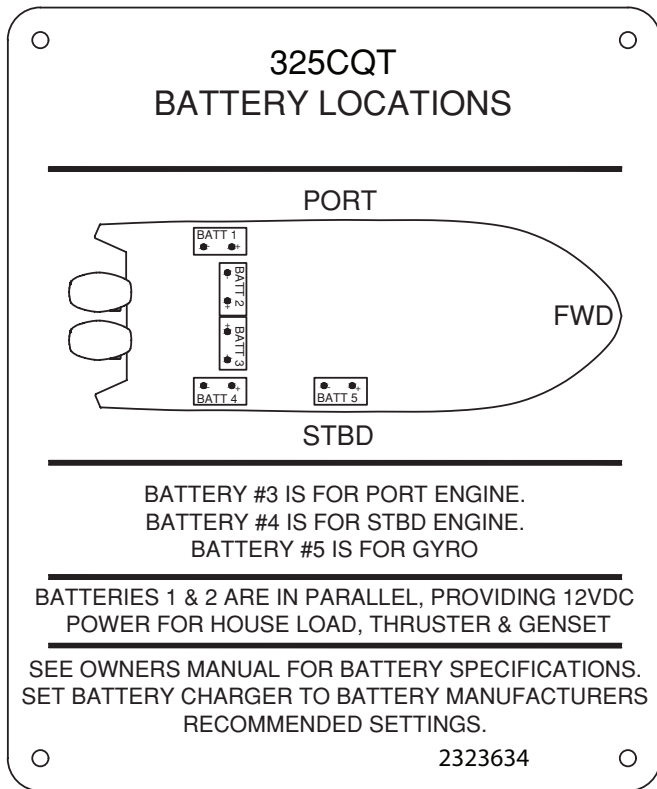

NOTICE

Even if the all switches are set to OFF. Certain features still draw power from the batteries. For example the Bilge pumps, NAUTIC-ON, and remote battery switching.

Remote Battery Switch Locations (FIGURE 4.2.2)

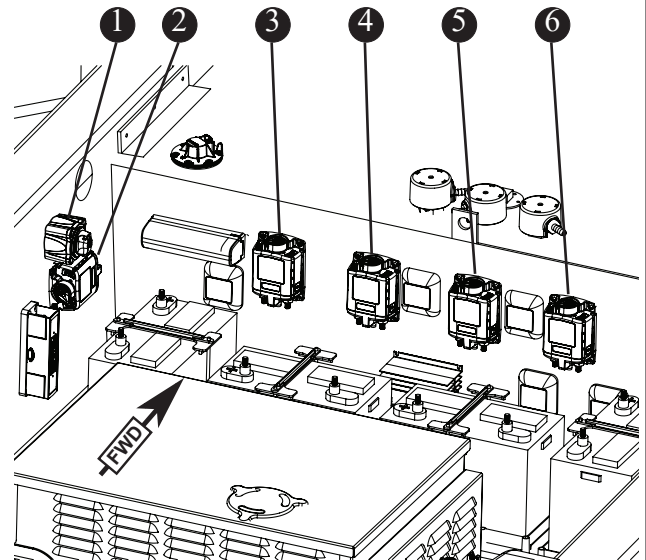

- 1 BOW THRUSTER BATTERY SWITCH
- 2 HOUSE REMOTE BATTERY SWITCH
- 3 PORT ENGINE AUTO CHARGING RELAY
- 4 PORT ENGINE REMOTE BATTERY SWITCH
- 5 STBD ENGINE AUTO CHARGING RELAY
- 6 STBD ENGINE REMOTE BATTERY SWITCH

Battery Trays (FIGURE 4.2.1)

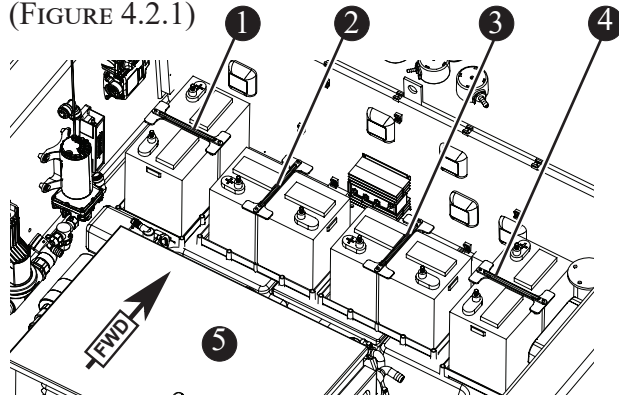

- 1 HOUSE BATTERY #1
- 2 HOUSE BATTERY #2
- 3 PORT ENGINE BATTERY
- 4 STARBOARD ENGINE BATTERY
- 5 GENERATOR

Remote Battery Switches (RBS)

! CAUTION

Stop engine(s) before moving battery switch(es) to off position.

This vessel uses remote battery switches (RBS), one for each engine and one for house power. These switches are used to control delivery of DC power from the batteries. These battery switches are advanced electric relay switches located on the forward bulkhead in the aft bilge area (see Figure 4.2.1). If the optional gyroscopic stabilizer is installed, there will be another RBS switch accessible under the prep station (Figure 4.3.1).

Each battery rocker switch on the DC distribution panel (see Figure 4.5.1) is wired to the its associated remote battery switch. When the engines are shut down or not providing a charge, the boats systems draw power from the house batteries. This allows you to run all the boats functions without affecting the engine's batteries.

Remote Battery Switch Locations
(FIGURE 4.3.1)

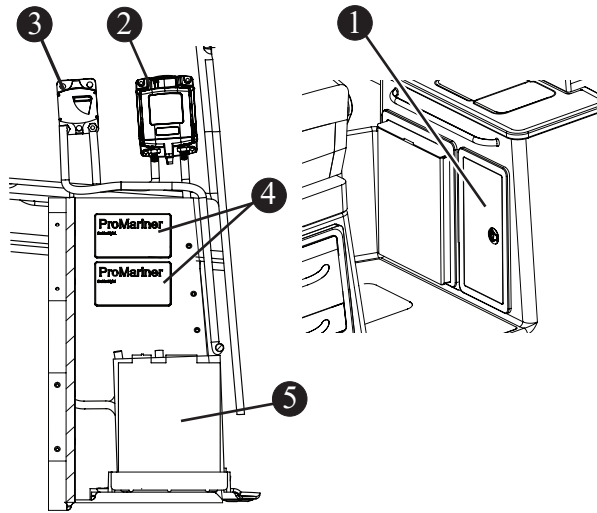

- ① GYRO* (OPTION) BATTERY COMPARTMENT
- ② GYRO* REMOTE BATTERY SWITCH
- ③ GYRO* 100 AMP BREAKER
- ④ GYRO* BATT CHARGER REMOTE DISPLAY
- ⑤ GYRO* BATTERY

*Gyroscopic stabilizer

Automatic Charging Relays (ACR)

Batteries are automatically connected in parallel through the use of automatic charging relays (ACR) when a sufficient charging source is present. The battery banks are automatically separated when the charging source falls below a certain voltage level for a predetermined amount of time.

The use of automatic charging relays eliminates the need for the operator to monitor battery voltage and decide whether or not to parallel the battery banks. It also eliminates the chance of a dead battery bank if a paralleling switch were left in the combined position without a sufficient charging source present. In an emergency, the operation of the automatic charging relays can be manually overridden by use of the knob on the top of the automatic charging relays.

Manual Control Override

Each of the remote battery switches and automatic charging relays have a manual override knob as an added level of safety that allows manual on/off control with or without power and provides lock off for servicing the electrical system.

Manual Control Override Knob Operation		
To combine battery banks	With Override Knob in (<i>REMOTE</i> position) push button until latched (push to latch on).	
To isolate battery banks that are connected	1. Rotate Override Knob to right to release button from latch on mode (button pops up). 2. Rotate Override Knob to left (<i>REMOTE</i> position).	
To prevent remote operation.	Rotate Override knob to right (<i>LOCK OFF</i> position).	
To secure for servicing.	With Override knob in (<i>LOCK OFF</i> position), pass cable tie through hole.	

REFER TO THE OWNER'S PACKET FOR COMPLETE INSTRUCTIONS AND WARRANTY INFORMATION.

Bow Thruster Switch

This vessel uses a battery switch for the bow thruster (if equipped) to control delivery of DC power from the batteries.

The battery switch is located on the port bulkhead inside the aft bilge compartment.

The bow thruster battery switch has two settings:

OFF - No power to bow thruster.

ON - Power to bow thruster

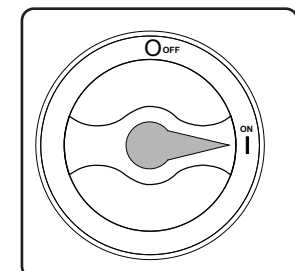
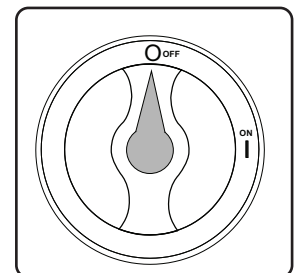
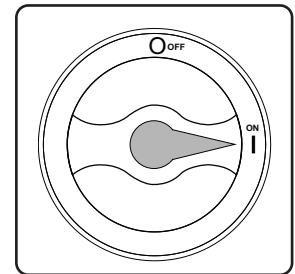

Battery Maintenance

DANGER

Batteries contain sulfuric acid which can cause serious injury. Avoid contact with skin, eyes and clothing. If contact occurs, immediately flush affected area with large quantities of water and obtain medical assistance.

CAUTION

- Never use an open flame in battery storage area.
- Avoid striking sparks near the battery.
- Battery will explode if flame or spark ignites free hydrogen given off during charging.
- Always disconnect battery before doing any work or maintenance on electrical system.
- Never turn off battery switches or disconnect battery cables while engines are running.

Before use, check each battery and the charging system for loose wiring connections. Normal maintenance should include:

- Coat terminals with dielectric grease
- Keep batteries dry
- If not using a sealed battery, check and maintain water level. Use distilled water only.
- Remove batteries from boat during cold weather or long term storage.

Draining a battery to zero before recharging can significantly reduce battery life. When a battery is totally discharged, the active material on both positive and negative plates converts to lead sulfate, causing the plates to become more alike in an electrical charge. The electricity conducting battery acid becomes weaker and the voltage drops. As the battery remains discharged, the process continues until recharging the battery becomes impossible.

Sometimes a battery may get left off a maintainer. It is paramount to give it a full charge before attempting to embark on a voyage. Most batteries will take 48-96 hours to fully charge depending on chemistry, technology, depth of discharge, capacity of maintainer, and general health of the battery. When preparing to restore batteries back to operation within the boat, it is paramount to test the batteries to ensure they are fully functional.

There are two primary aspects to consider - State of Charge (SOC) and State of Health (SOH). A good test device will determine if a “surface charge” is giving a false indication of a good charge state. SOH is not as common as SOC but does indicate remaining useful life of the battery. A test device measures the internal resistance over a frequency range to give you a SOH reading. While it would be prudent to replace a battery if SOH is less than 50 percent, do not put a battery into service that has less than 30 percent SOH. A battery load tester is a general indicator of a battery’s ability to provide a cranking current, but it is not as accurate as actual SOC and SOH readings.

Main DC Distribution Panel (including options)
(FIGURE 4.5.1)

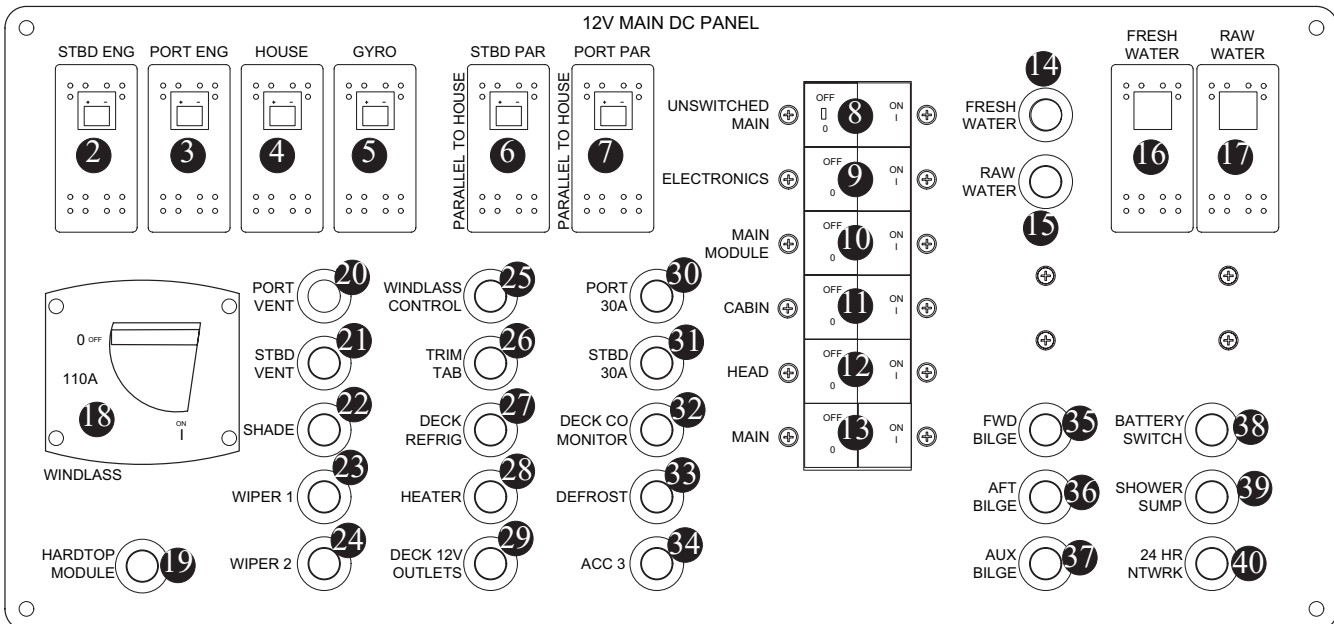
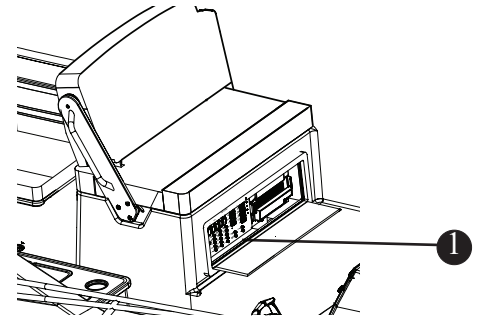

- | | |
|--|--|
| 1 MAIN DC DISTRIBUTION PANEL | 22 SHADE BREAKER (OPTION)5 AMP |
| 2 STARBOARD BATTERY SWITCH | 23 PORT WIPER BREAKER..... 10 AMP |
| 3 PORT BATTERY SWITCH | 24 STARBOARD WIPER BREAKER.. 10 AMP |
| 4 HOUSE SWITCH | 25 WINDLASS CONTROL BREAKER.. 10 AMP |
| 5 GYRO STABILIZER SWITCH (OPTION) | 26 TRIM TAB BREAKER 20 AMP |
| 6 STARBOARD PARALLEL SWITCH | 27 DECK FRIDGE BREAKER (OPTION). 15 AMP |
| 7 PORT PARALLEL SWITCH | 28 HEATER BREAKER (OPTION) 15 AMP |
| 8 UNSWITCHED MAIN BREAKER ..50 AMP | 29 DECK 12V OUTLET BREAKERS ... 10 AMP |
| 9 ELECTRONICS BREAKER 60 AMP | 30 PORT RECEPTACLES BREAKER
(OPTION)..... 30 AMP |
| 10 MAIN MODULE BREAKER..... 60 AMP | 31 STARBOARD RECEPTACLES BREAKER
(OPTION)..... 30 AMP |
| 11 CABIN BREAKER..... 60 AMP | 32 DECK CO MONITOR BRKR(OPTION) ... 2 AMP |
| 12 HEAD BREAKER 40 AMP | 33 DEFROSTER BREAKER 15 AMP |
| 13 MAIN BREAKER 150 AMP | 34 ACCESSORY 3 BREAKER..... 10 AMP |
| 14 FRESH WATER BREAKER 15 AMP | 35 FWD BILGE PUMP BREAKER..... 6 AMP |
| 15 RAW WATER BREAKER..... 15 AMP | 36 AFT BILGE PUMP BREAKER 12 AMP |
| 16 FRESH WATER SWITCH | 37 AUX BILGE PUMP BREAKER..... 12 AMP |
| 17 RAW WATER SWITCH | 38 BATTERY SWITCH BREAKER 15 AMP |
| 18 WINDLASS MAIN BREAKER 110 AMP | 39 SHOWER SUMP BREAKER..... 3 AMP |
| 19 HARDTOP MODULE BREAKER... 30 AMP | 40 24-HOUR NETWORK BREAKER.... 5 AMP |
| 20 PORT VENT BREAKER 10 AMP | |
| 21 STARBOARD VENT BREAKER 10 AMP | |

Battery Charger

The battery charger, mounted on the starboard side of the bilge (see Figure 4.6.1) automatically increases current output when there is a drop in battery voltage. When the batteries are charged, the unit maintains a small current flow to keep the batteries fully charged and ready for service without overcharging.

If your vessel is equipped with the gyroscopic stabilizer option there are two more battery chargers that can be accessed by removing the storage compartment under the grill. Gyroscopic stabilizer battery charger status can be viewed remotely inside the gyroscopic stabilizer battery compartment under the prep station (Figure 4.3.1).

Overload Protection

If an electrical short or overload occurs in the electrical system the charger will reduce its output voltage to avoid internal damage. When an electrical short occurs, the red LED on the front panel of the unit will be illuminated. The overload or short must be removed in order for the charger to resume charging characteristics.

Charge Rate

The battery charger has selectable profiles that affect the charge rate. The charge rate profile is pre-set at the factory to AGM to match the battery type installed on your vessel. Matching the charge rate to the battery type installed extends battery life and maximizes battery performance. Refer to your battery charger manual in the owner's packet for complete instructions and additional information.

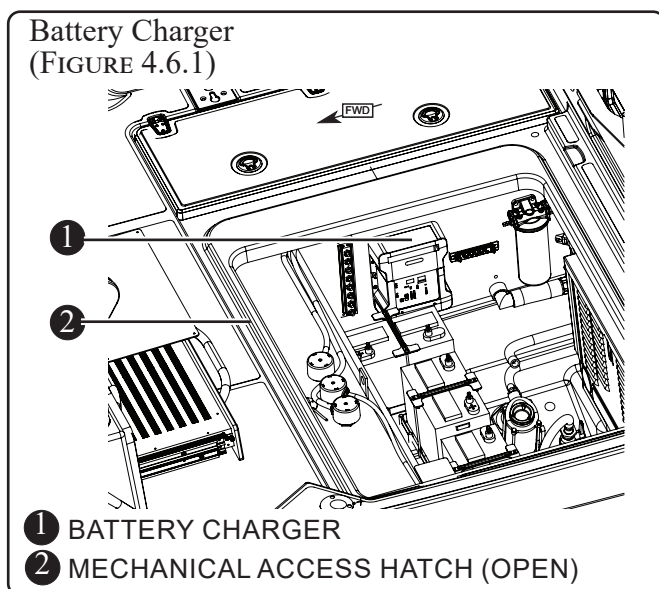

Maintenance

The charger is fully automatic and requires no maintenance. However, the battery terminals should be cleaned periodically with baking soda and all connections tightened to provide trouble free operation.

REFER TO THE OWNER'S PACKET FOR COMPLETE INSTRUCTIONS AND WARRANTY INFORMATION.

AC Electrical System

CAUTION

- It is imperative that the shore power receptacles are dry before plugging into the dockside power receptacle.
- Route and tie the power cord from the boat to the dockside power box to prevent people tripping over it and injuring themselves.
- The shore power cord should also be routed or secured to prevent falling into the water causing stress on the plugs and receptacles.
- The use of extension cords for shore power is not recommended. Extensions can cause a voltage drop and may prevent some electronic devices from operating correctly.

Shore Power

In addition to the primary DC electrical system, this vessel is equipped with shore power capabilities which can be used while docked to energize the systems on this vessel. This includes systems which require power beyond the capabilities of the batteries:

SHORE POWER 1	SHORE POWER 2
AFT BATTERY CHARGER	WATER HEATER (OPTION)
A/C PUMP (OPTION)	STOVE
CABIN A/C (OPTION)	DECK A/C (OPTION)
120 VOLT OUTLETS	GYRO CHARGER (OPTION)
CABIN REFRIGERATOR	DECK REFRIGERATOR (OPTION)
MICROWAVE	GRILL (OPTION)

A 50 ft (15.24 m) shore power cord (included) with weather tight plugs is used to connect to dockside power facilities.

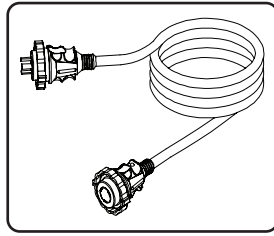

Shore Power
(FIGURE 4.7.1)

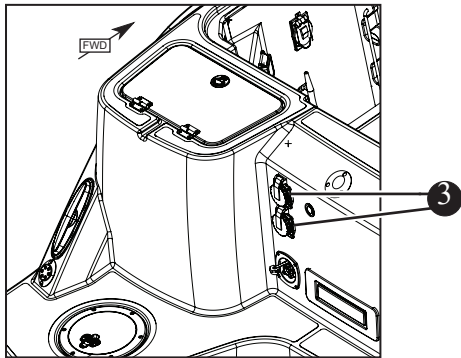
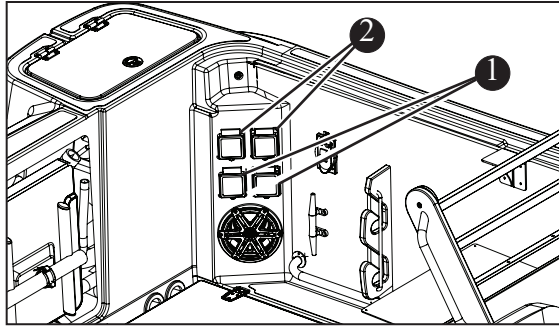

- ① SHORE POWER INTERMEDIATE BREAKER
- ② EQUIPT LEAKAGE CIRCUIT INTERRUPTER
- ③ SHORE POWER INLET

NOTICE

Be sure that the boat is securely moored before connecting to shore power.

Equipment Leakage Circuit Interrupter (ELCI)

⚠ DANGER

Receptacle will not protect against line-to-line or line-to-neutral faults, short circuits or overloads.

The shore power system on the boat includes an equipment leakage circuit interrupter located on starboard gunwale (see Figure 4.7.1). The equipment leakage circuit interrupter is designed to protect people from line-to-ground shock hazards which may

occur from defective, misused or neglected electrical equipment. The circuit interrupter will not prevent line-to-ground electric shock, but does limit the time of exposure to a period considered safe for normal healthy persons. If an imbalance of current is sensed, the circuit interrupter will trip when the ground fault exceeds 0.030 amps. This tripping action will occur within a fraction of a second to prevent serious injury.

Testing and Troubleshooting Test Before Each Use

Normal operating state - Sensing device green LED is on and circuit breaker is at on position.

1. Press test button. Green LED should go out and red LED should come on and circuit breaker should trigger to off position.
2. If sensing device LED or breaker does not trip or change state, do not use. Consult an electrician for assistance.
3. Press reset button. The red LED should turn off and the green LED should turn on.
4. Manually reset (switch) circuit breaker to on position to restore circuit power.

If above tests fail, do not use. Repair or replace shore power unit.

Connecting Shore Power

⚠ CAUTION

Never operate 120 volt shore power if the voltmeter registers less than 110 volts or more than 125 volts.

1. On the boat:

- Ensure *Shore Power Main* breaker and all equipment breakers on the AC main distribution panel are off.
- Ensure shore power intermediate breaker is off.
- Ensure that the inlet and plugs are dry. Spray a moisture repellent into the inlet and cord plugs.

- Plug power cord end into shore power inlet. Turn clockwise to thread locking ring and prevent accidental unplugging.

2. On the dock:

- Turn off dock breaker.
- Ensure the receptacle and plugs are dry. Spray moisture repellent into receptacle.
- Plug power cord end into dockside receptacle.
- Turn on dockside breaker.

3. On the boat:

- Turn on shore power intermediate breaker.
- Turn on the *Shore Power Main* breaker on the main DC distribution panel. Check the AC voltmeter for proper voltage.
- Turn on equipment breakers.

Disconnect Shore Power

1. On the boat:

- Turn off all equipment breakers on the AC main distribution panel.
- Turn off the *Shore Power Main* breaker on the main distribution panel.
- Turn off shore power intermediate breaker.

2. On the dock:

- Turn off the dockside breaker.
- Disconnect dockside end of power cord.

3. On the boat:

- Disconnect power cord from shore power inlet
- Clean power cord, spray plugs with moisture repellent, and store cord in a dry location on boat.

It is imperative that shore power cord and plug ends are kept clean and dry. This is especially important if this vessel is used in salt water. Always clean and spray your cord ends with moisture repellent before using and before storing the cord.

Galvanic Isolator

⚠ CAUTION

Under normal conditions the anodes on this vessel should last one season. If abnormal deterioration of the anodes occur a problem exists and should be corrected immediately.

This vessel is equipped with a galvanic isolator, which blocks low voltage DC on the shore power ground wire. The galvanic isolator prevents dockside electrolytic voltages from damaging the metal parts of this vessel which come in contact with the water. Additionally, the galvanic isolator will safely conduct high currents (above 1.5 volts) to ground in the event of a short circuit or power leakage on this vessel.

Maintenance

The galvanic isolator unit is highly reliable. It should, however, be tested once per season, and re-tested after a condition that may have influenced it, such as a lightning strike in the vicinity, or on-board electrical short that either caused a circuit breaker or fuse to blow.

REFER TO THE OWNER'S PACKET FOR COMPLETE INSTRUCTIONS AND WARRANTY INFORMATION.

Component Breakers

⚠ CAUTION

Never reset a breaker without first determining and correcting the cause of the trip. Should a circuit repeatedly trip, have a qualified electrician determine and correct the cause.

Component reset breakers are located on the main DC distribution panel located in an access door beneath (see Figure. 4.5.1). If a component breaker trips, determine and correct the problem

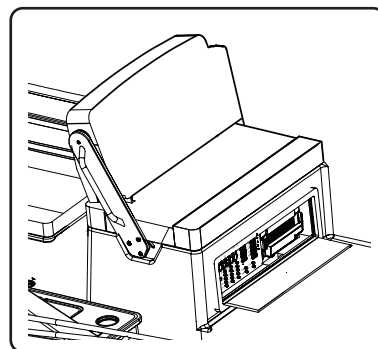

before resetting the breaker. Should a circuit breaker trip repeatedly, have a qualified electrician determine and correct the cause of the trip.

Fuse Block

WARNING

Use of higher amperage fuses or breakers is a fire hazard.

Use fuses and breakers having the same amperage rating as the original or as specified.

There are two electronics fuse blocks. One is located inside the bilge compartment. The other is located in the starboard cabin electronics compartment.

In the event you need to replace a fuse, use the same amperage as the original. It is recommended that you carry spare fuses.

If a fuse is replaced with one of lower amperage, it will not be sufficient to carry the electrical load of the equipment it is connected to and will cause nuisance fuse failure or breaker tripping.

If a fuse is replaced with one of higher amperage, it will not provide adequate protection against an electrical malfunction and will create a fire hazard.

Ground Fault Interrupter (GFI)

This vessel is equipped with a ground fault interrupter receptacle located inside the port cabin cabinet below the cabin DC panel. Please read and understand the following caution regarding GFI receptacles.

CAUTION

Persons with heart problems or other conditions which may make them susceptible to electric shock may still be injured by ground faults on circuits protected by a GFI receptacle. No safety devices yet designed will protect against all hazards or carelessly handled or misused electrical equipment or wiring.

The GFI receptacle is designed to protect people from the line-to-ground shock hazards which could occur from defective tools or appliances operating from the receptacle, or from down-line outlets protected by it.

The GFI will not prevent line-to-ground electric shock, but does limit the time of exposure to a period

considered safe for normal healthy persons. The receptacle will not protect people against line-to-line or line-to-neutral faults, short circuits or overloads.

International Option

All readily accessible 220V outlets are protected by a residual current circuit breaker (RCCB). This current breaker includes a test switch to verify proper operation. Its function is similar, but not identical to a GFI receptacle.

12 Volt Accessory Receptacles



NOTICE

Do not insert a cigarette lighter into receptacle. Damage to the unit and system could occur.

This vessel is equipped with two 12 volt accessory receptacles. One is located on the helm dash top. The other on the dash top in front of the companion seat. (see Figure 4.0.1). The 12 volt accessory circuit is protected by a 10 amp breaker located on the main DC distribution panel. Be sure to use accessories that when combined do not exceed the rated capacity of the circuit, (10 amps) or the breaker will trip.

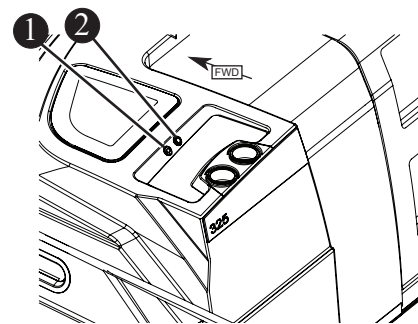
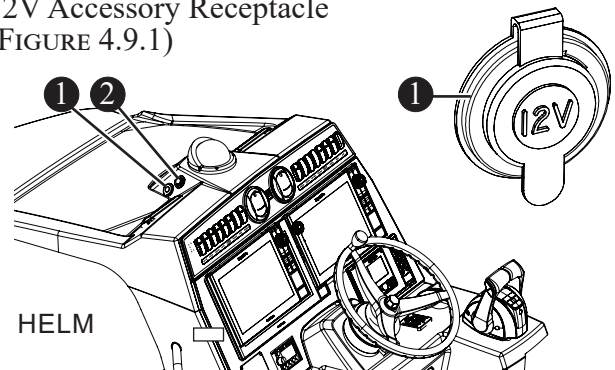
12V Accessory Receptacle
(FIGURE 4.9.1)



-  12V ACCESSORY RECEPTACLE
-  USB RECEPTACLE

Electric Downrigger Receptacles (Option)

If equipped, the two 12V DC electrical receptacles for powering electric downriggers, or any electrical equipment aptly rated, are located on the port and starboard gunwales (see Figure 4.10.1).

The receptacles are active when the battery switches are on. The receptacles are protected by a weatherproof cover.

REFER TO THE OWNER'S PACKET FOR COMPLETE INSTRUCTIONS AND WARRANTY INFORMATION.



CAUTION

The location for mounting of a downrigger base is important, refer to the reinforcement location diagram (see chapter 5, Care and Maintenance) for areas on the gunwales that may be able to withstand the stress generated by a downrigger.

There are a variety of downrigger mounting base plates that can be used, it is important that you consult with your dealer to find the mounting base that will best suit your application.

12V/DC Receptacle (option)
(FIGURE 4.10.1)

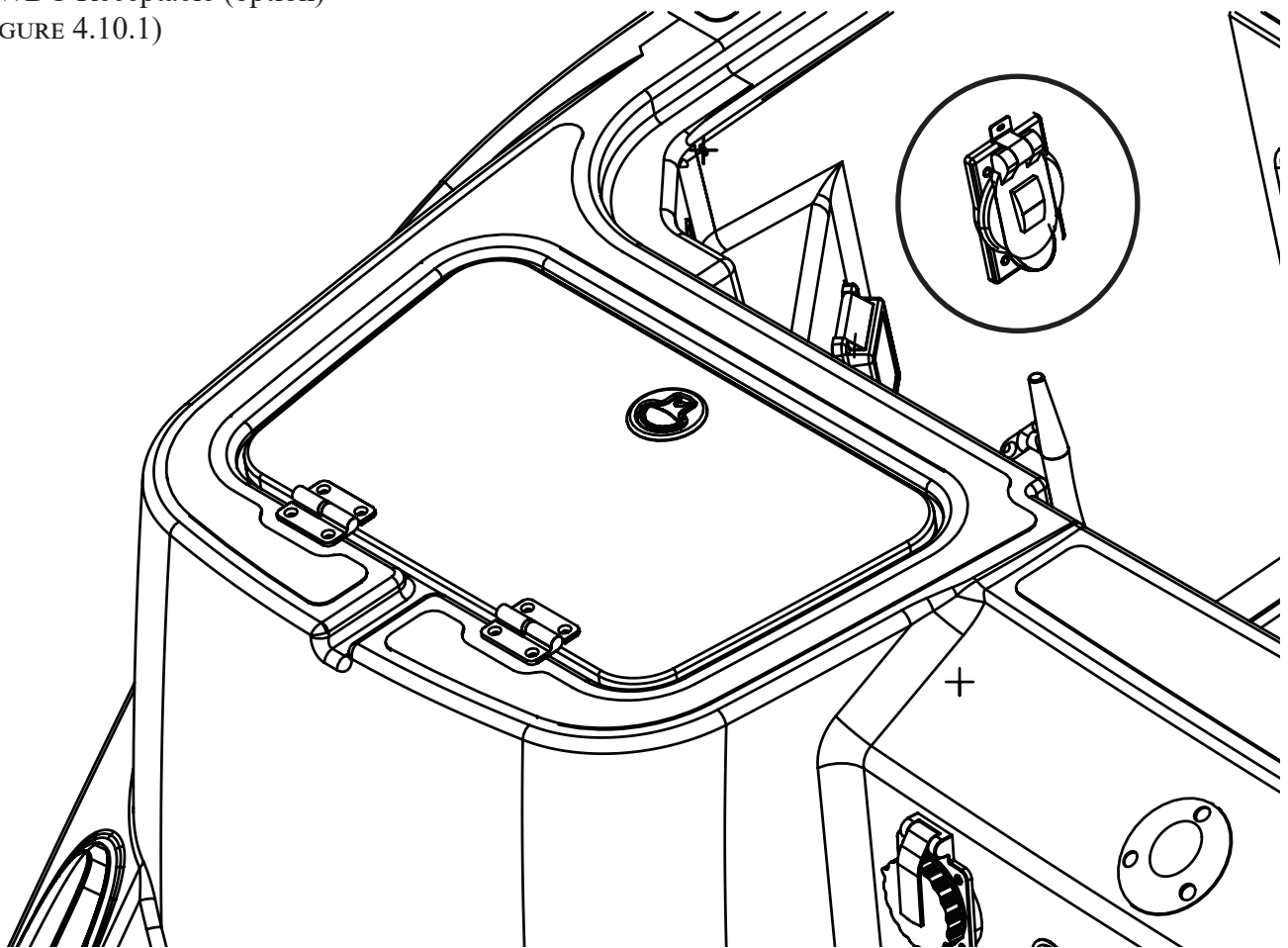

NOTE: Starboard side receptacle not shown

Distribution Panels

The DC and AC distribution panels are located in the port upper cabinet of the galley. These panels contain the main breaker switches.

CAUTION

Never reset a breaker without first correcting the cause of the trip. If a circuit repeatedly trips, have a qualified electrician determine and correct the cause.

120VAC/12V DC Distribution Panels (FIGURE 4.11.1)

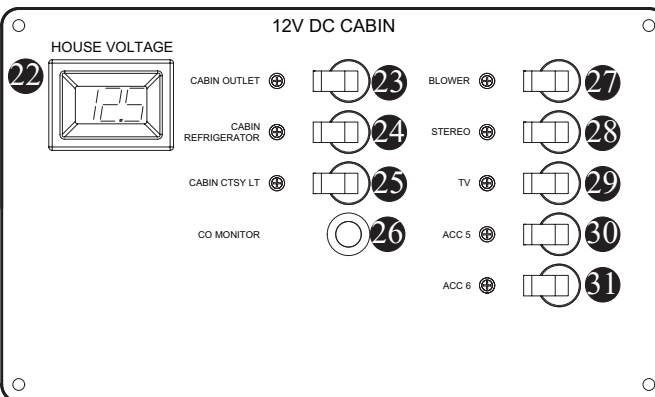
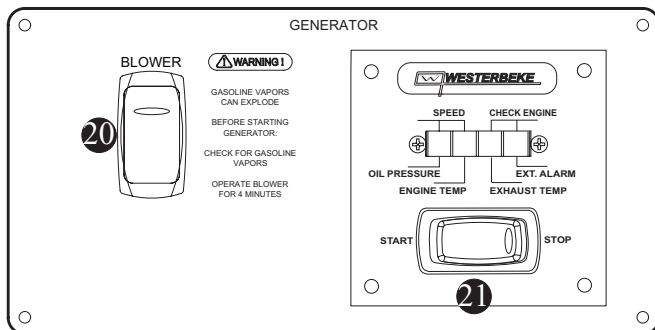
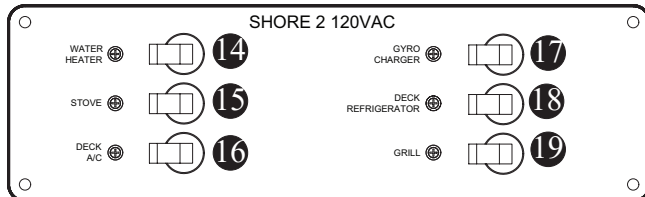
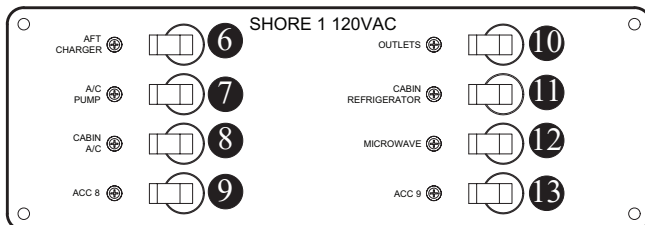
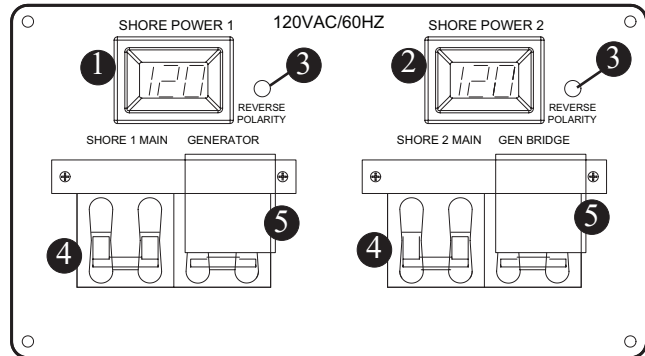

- 1 SHORE POWER 1 VOLTMETER
- 2 SHORE POWER 2 VOLTMETER
- 3 REVERSE POLARITY INDICATOR LIGHT
- 4 SHORE POWER MAIN (30 AMP)
- 5 GENERATOR MAIN (70 AMP)
- 6 AFT CHARGER (15 AMP)
- 7 A/C PUMP (2 AMP)
- 8 CABIN A/C (20 AMP)
- 9 ACCESSORY 8 (10 AMP)
- 10 120V OUTLETS (10 AMP)
- 11 CABIN REFRIGERATOR (15 AMP)
- 12 MICROWAVE (10 AMP)
- 13 ACCESSORY 9 (10 AMP)
- 14 WATER HEATER (12 AMP)
- 15 STOVE (10 AMP)
- 16 DECK A/C (25 AMP)
- 17 GYROSCOPIC STABILIZER CHARGER (30 AMP)
- 18 DECK REFRIGERATOR (12 AMP)
- 19 GRILL (12 AMP)
- 20 BLOWER SWITCH
- 21 GENERATOR SWITCH
- 22 HOUSE VOLTMETER
- 23 CABIN OUTLET (10 AMP)
- 24 CABIN REFRIGERATOR (15 AMP)
- 25 CABIN COURTESY LIGHT BRKR (8 AMP)
- 26 CO MONITOR (2 AMP)
- 27 BLOWER (7 AMP)
- 28 STEREO (10 AMP)
- 29 TV (10 AMP)
- 30 ACC 5 (10 AMP)
- 31 ACC 6 (10 AMP)

230VAC and 12VDC Distribution Panels (FIGURE 4.12.1)

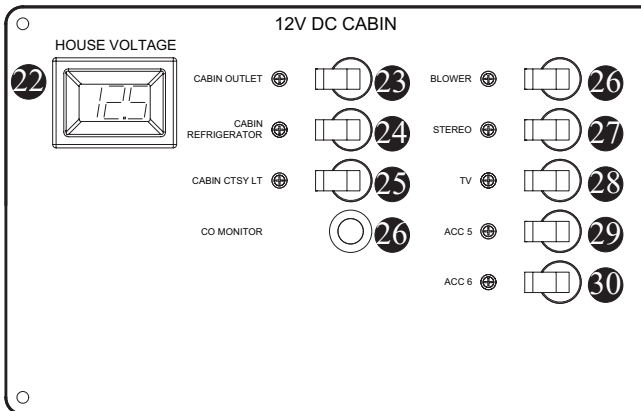
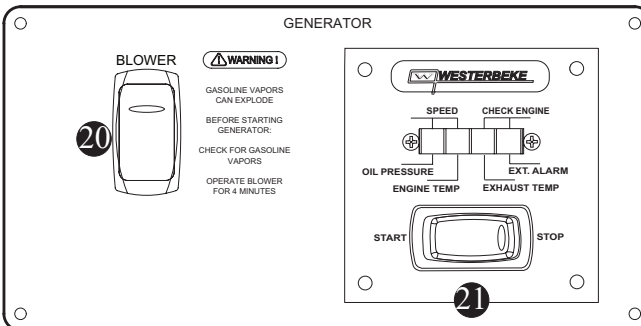
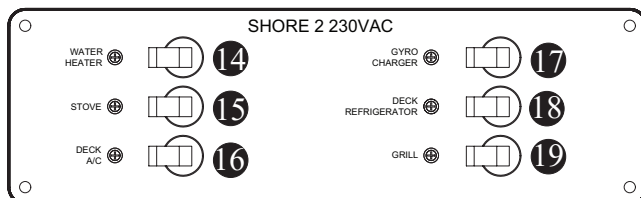
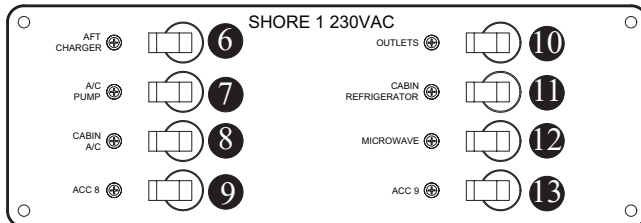
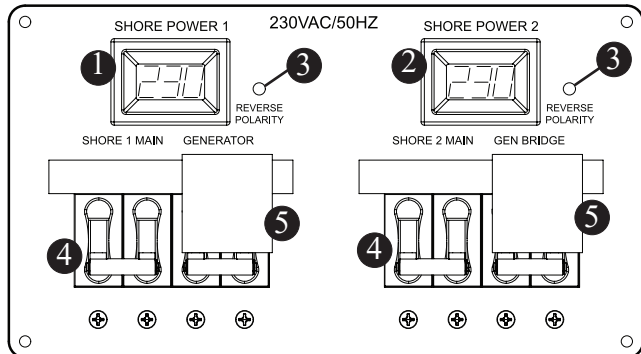

- 1 SHORE POWER 1 VOLTMETER
- 2 SHORE POWER 2 VOLTMETER
- 3 REVERSE POLARITY INDICATOR LIGHT
- 4 SHORE POWER MAIN (15 AMP)
- 5 GENERATOR MAIN (35 AMP)
- 6 AFT CHARGER (8 AMP)
- 7 A/C PUMP (2 AMP)
- 8 CABIN A/C (10 AMP)
- 9 ACCESSORY 8 (5 AMP)
- 10 120V OUTLETS (8 AMP)
- 11 CABIN REFRIGERATOR (5 AMP)
- 12 MICROWAVE (5 AMP)
- 13 ACCESSORY 9 (8 AMP)
- 14 WATER HEATER (6 AMP)
- 15 STOVE (5 AMP)
- 16 DECK A/C (13 AMP)
- 17 GYROSCOPIC STABILIZER CHARGER (15 AMP)
- 18 DECK REFRIGERATOR (6 AMP)
- 19 GRILL (6 AMP)
- 20 BLOWER SWITCH
- 21 GENERATOR SWITCH
- 22 HOUSE VOLTMETER
- 23 CABIN OUTLET (10 AMP)
- 24 CABIN REFRIGERATOR (15 AMP)
- 25 CABIN COURTESY LIGHT BRKR (8 AMP)
- 26 CO MONITOR (2AMP)
- 27 BLOWER (7AMP)
- 28 STEREO (10 AMP)
- 29 TV (10 AMP)
- 30 ACC 5 (10 AMP)
- 31 ACC 6 (10 AMP)

Rigging

Factory-installed rigging pulls are provided to facilitate running new wiring (see Figure 4.13.1). This vessel is equipped with three rigging pulls that have been bundled and tied at either end of three rigging tubes. The first two pulls are located port and starboard of the mechanical access hatch, inside rigging troughs under the deck. The third pull is in the starboard hardtop frame, with one end inside the prep station and the other terminating in the hardtop behind the starboard speaker enclosure. In preparation for potential future use of the rigging tubes, be sure to attach and pull a cord through with each run of new wiring.

Rigging
(FIGURE 4.13.1)

- ① RIGGING TUBE
- ② AFT PULL CORD
- ③ FORWARD PULL CORD
- ④ RIGGING TUBE
- ⑤ AFT PULL CORD
- ⑥ FORWARD PULL CORD
- ⑦ LOWER PULL CORD
- ⑧ UPPER PULL CORD
- ⑨ HARDTOP

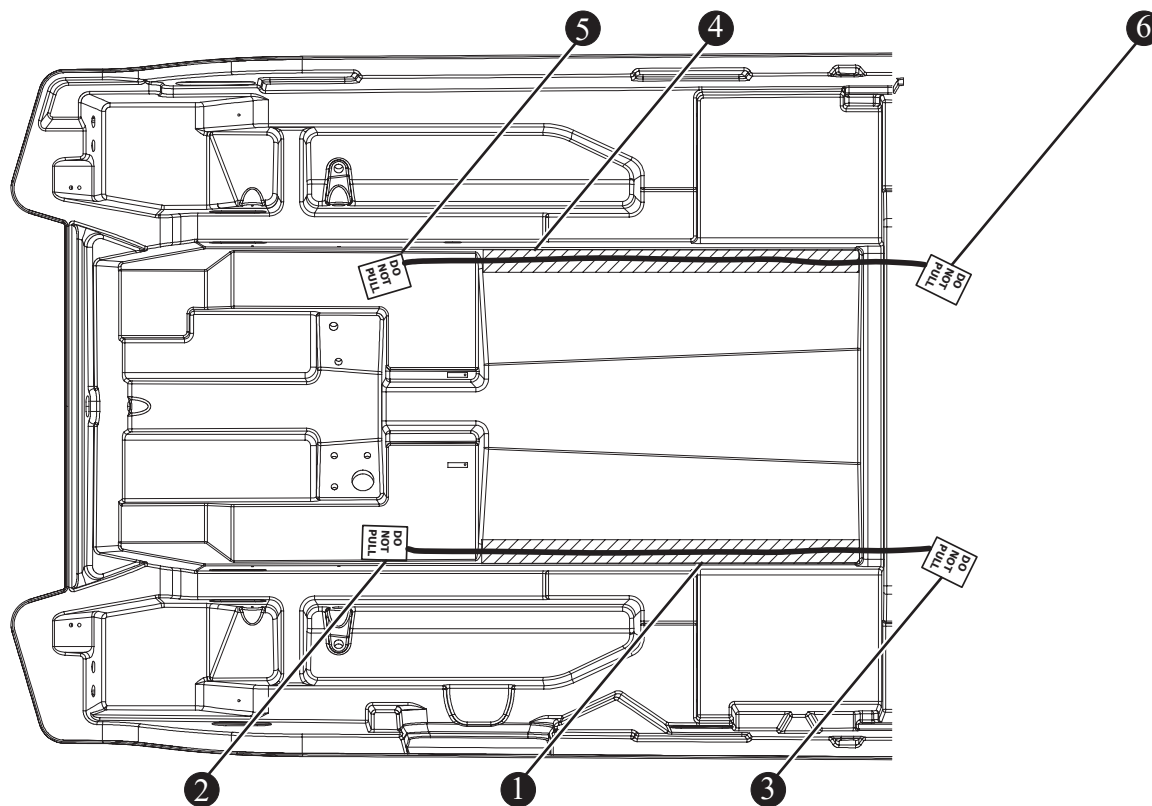
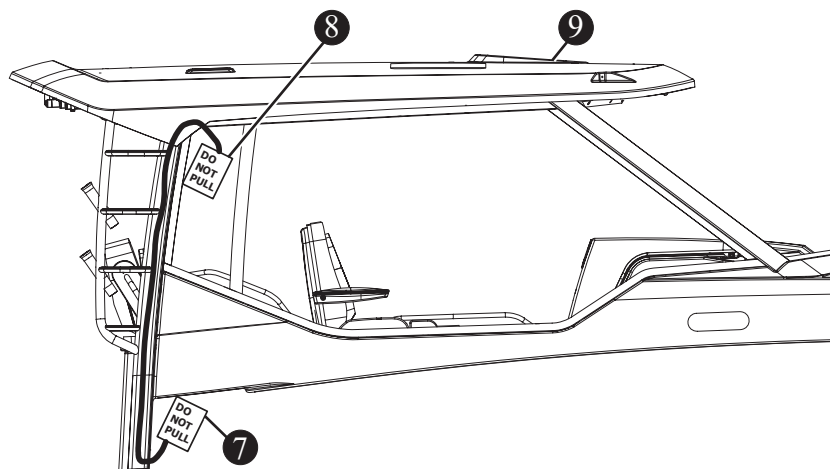

NAUTIC-ON™ Remote Connectivity* (option)

- 24/7 access to your boat's information using the NAUTIC-ON app
- Monitor house and engine battery state and bilge pump activity
- Review live engine data and diagnostics
- Track location with smart bread crumbing and geofence
- View weather conditions at the boat

*A limited subscription is included and thereafter the service is subscription based.

REFER TO THE OWNER'S PACKET FOR COMPLETE INSTRUCTIONS AND WARRANTY INFORMATION.

Transducer

The transducer, located in the mechanical access hatch, acts as an antenna for the sonar system, sending sound waves through the water, bouncing off objects, and returning a signal (see figure 4.14.1).

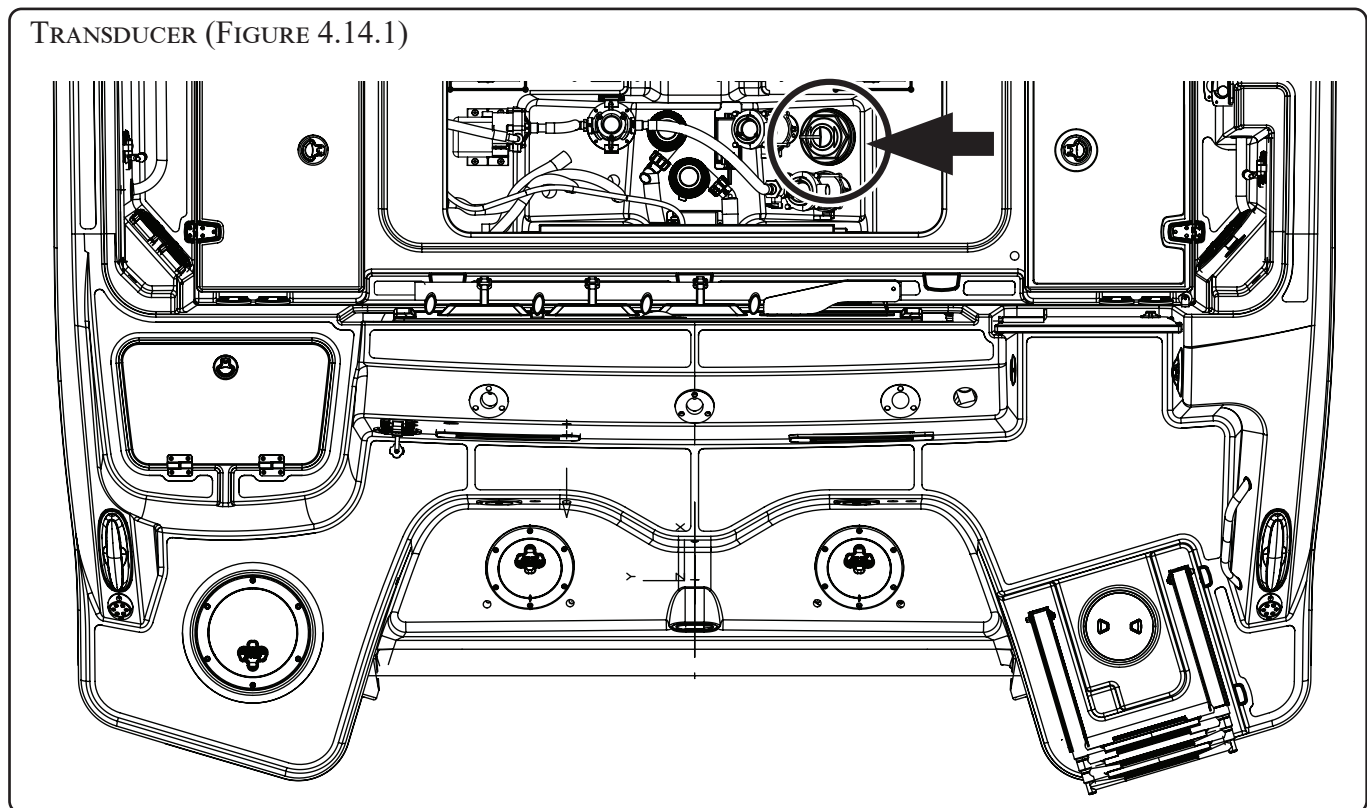

C-Zone™ Digital Switching

C-Zone is a networked digital switching interface that provides electrical system monitoring and control using the multi-function displays. Centralized breaker panels are replaced by a series of power modules strategically located throughout the boat that can be customized as needed. These modules are connected via a bus system to screens and switches for control and monitoring of the electrical system via the Raymarine navigational monitor and/or the VesselView display. See figures 4.15.1 through 4.20.1.

C-Zone Control 1 Module
(FIGURE 4.15.1)

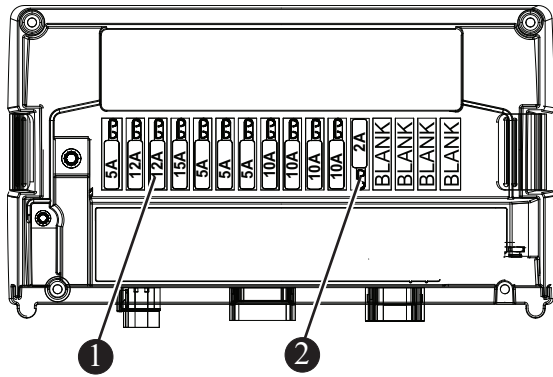

- 1 FUSE (NORMAL POSITION)
- 2 FUSE (BYPASS POSITION)

C-Zone Output Interface Module
(FIGURE 4.15.2)

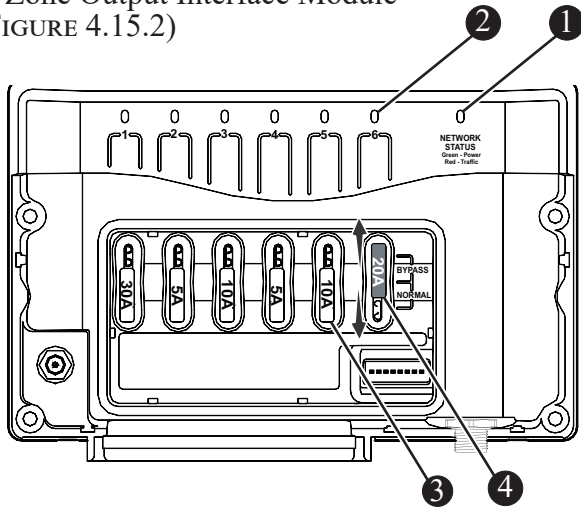

- 1 POWER/CURRENT INDICATOR (LED)
- 2 CHANNEL CURRENT INDICATOR (LED)
- 3 FUSE (NORMAL POSITION)
- 4 FUSE (BYPASS POSITION)

C-Zone Modules

The control one modules and output interface (OI) provide the control and fusing for circuits throughout the boat. In the event of a system failure or to test the output channels manually, the channels can be easily placed into manual override position.

There is a label on the inside of the output interface cover which shows the LED codes and manual bypass instructions (Figure 4.15.3).

LED Flash Code Label
(FIGURE 4.15.3)

LED Flash Codes: Fault Description		manual Bypass: Remove fuse from "normal" (lower) position and place into "bypass" (upper position). Ignition Danger! Ensure area is free of explosive gases before removing or replacing fuse!
Channel Status LED Indicator		
Gn solid on	Channel on	
Gn slow flash	Channel in timer mode	
1x RED	Channel not configured	
2x RED	Configuration conflict	
3x RED	Dip switch conflict	
4x RED	Memory comms failure	
5x RED	No modules detected	
6x RED	Low Run Current	
7x RED	Over current	
8x RED	Short circuit	
9x RED	Missing commander	
10x RED	Reverse current	
11x RED	Current calibration	

Circuit Bypass
(FIGURE 4.15.4)

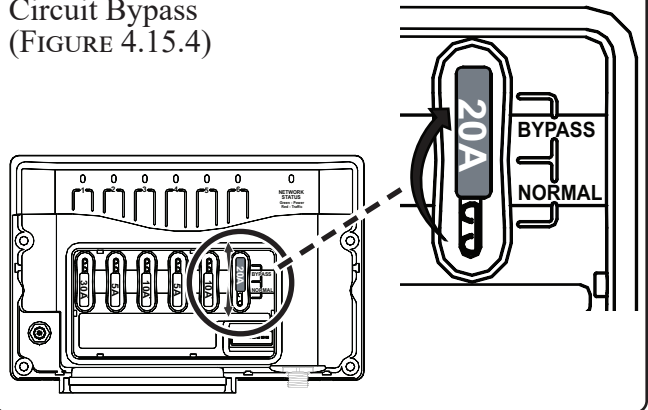

To Bypass or Test Circuit

CAUTION

Bypassing can cause a potential ignition source. Ensure surrounding area is free of flammable/explosive gases and vapors.

- Remove the output interface module cover.
- Locate the channel to bypass.
- Remove fuse from *NORMAL* position.
- Place fuse in *BYPASS* position (Figure 4.15.4).

All internal electronics and software control has now been bypassed providing complete mechanical bypass.

NOTICE

Contact your dealer if it becomes necessary to use the *BYPASS* position for continuous operation of a circuit.

C-Zone™ Wireless Remote

The C-Zone wireless remote control key fob provides wireless ability to operate four circuits from a distance of up to 250 ft. (80 m). To activate a selected circuit simply push the appropriate button.

C-Zone Wireless Remote Key Fob
(FIGURE 4.16.1)

- ① HOUSE BATTERY SWITCH ON
- ② INTERIOR LIGHTS ON/OFF
- ③ WHITE COURTESY LIGHTS ON
- ④ WHITE COURTESY LIGHTS OFF

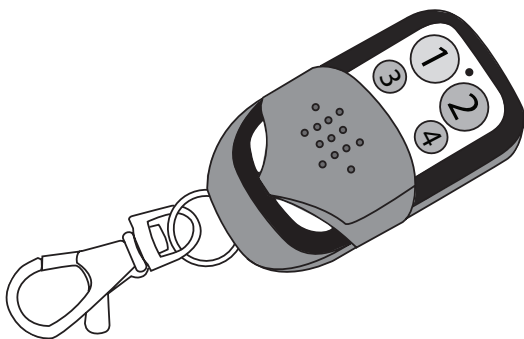

C-Zone/Raymarine Interface

! CAUTION

Do not update software, on either the Raymarine Navigation System or the Vessel View unit without first contacting your dealer or Boston Whaler. To do so will negatively impact your ability to access Digital Switching.

The control modules for the C-Zone and Raymarine are located on the port wall of the electronics bay and can be accessed through a panel behind the port cabin lounge. Press the *DASHBOARD* icon to launch the C-Zone switching interface screen. Use the pan arrow on the right side of the screen to pan to the first of two screens which enable you to monitor and, in some cases, interface with various systems on this vessel.

REFER TO THE OWNER'S PACKET FOR COMPLETE INSTRUCTIONS AND WARRANTY INFORMATION.

C-Zone Interface (FIGURE 4.16.2)

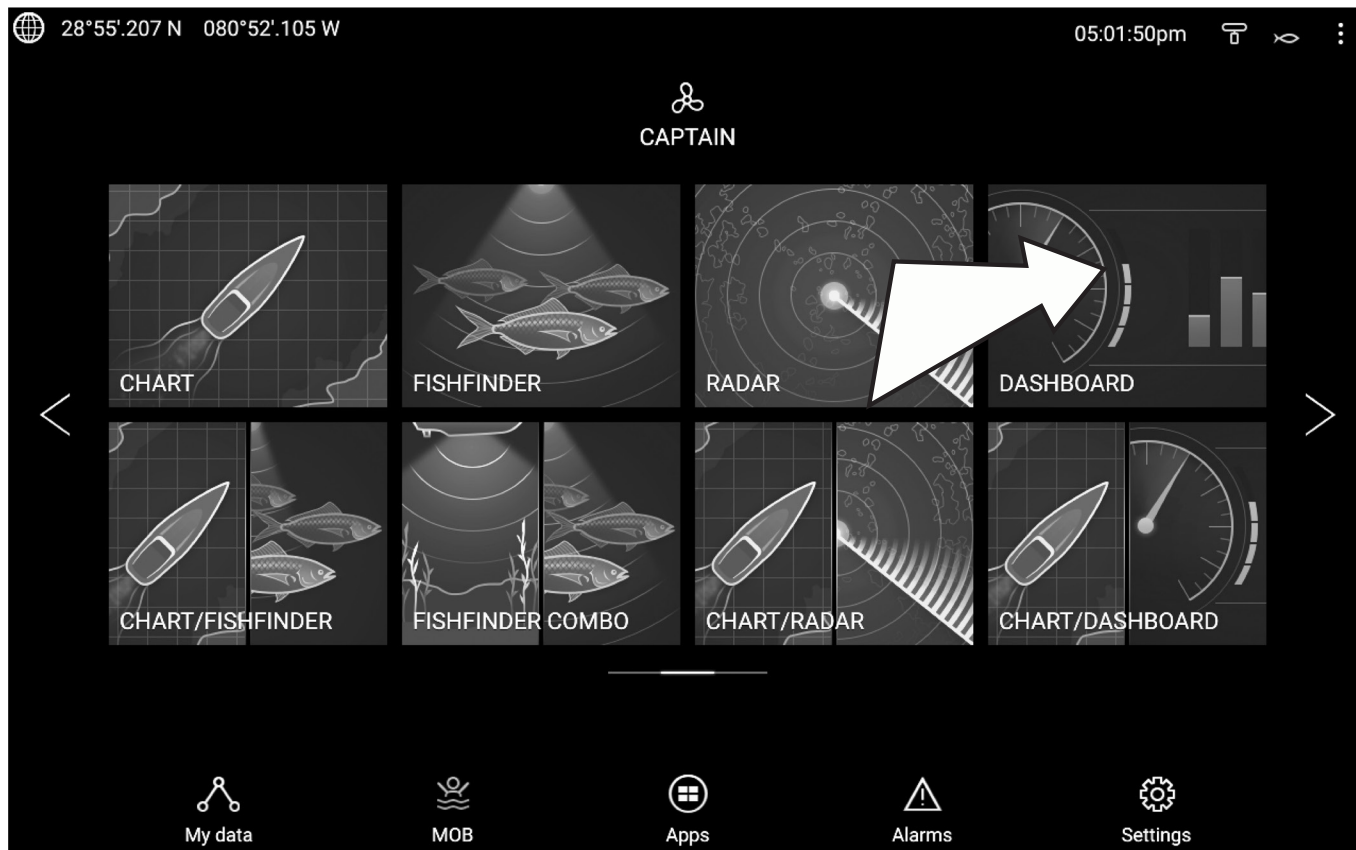

Chapter 4 • Electrical

C-Zone/Raymarine Digital Switching Interface (FIGURE 4.17.1)

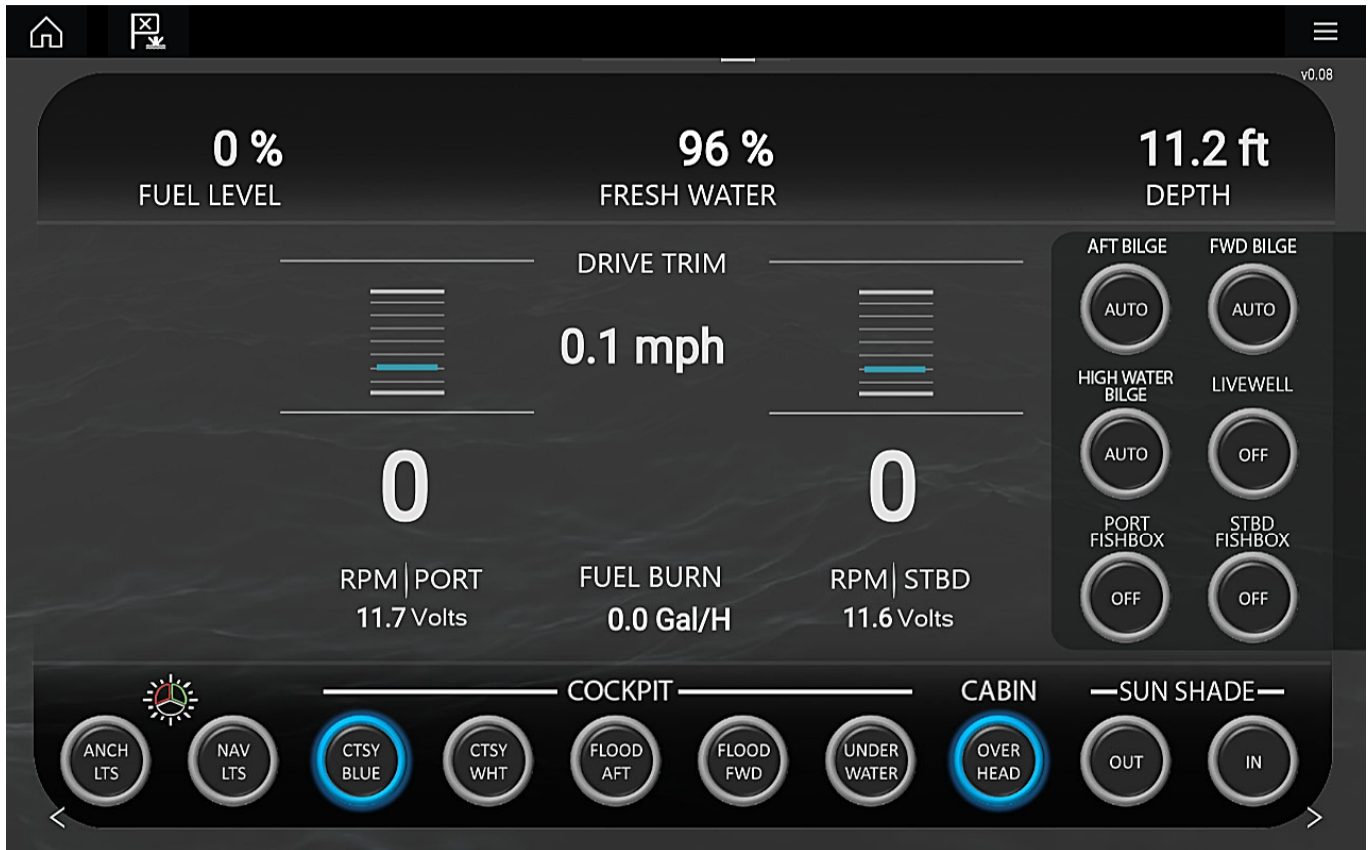

C-Zone/Raymarine Digital Switching Interface (FIGURE 4.17.2)

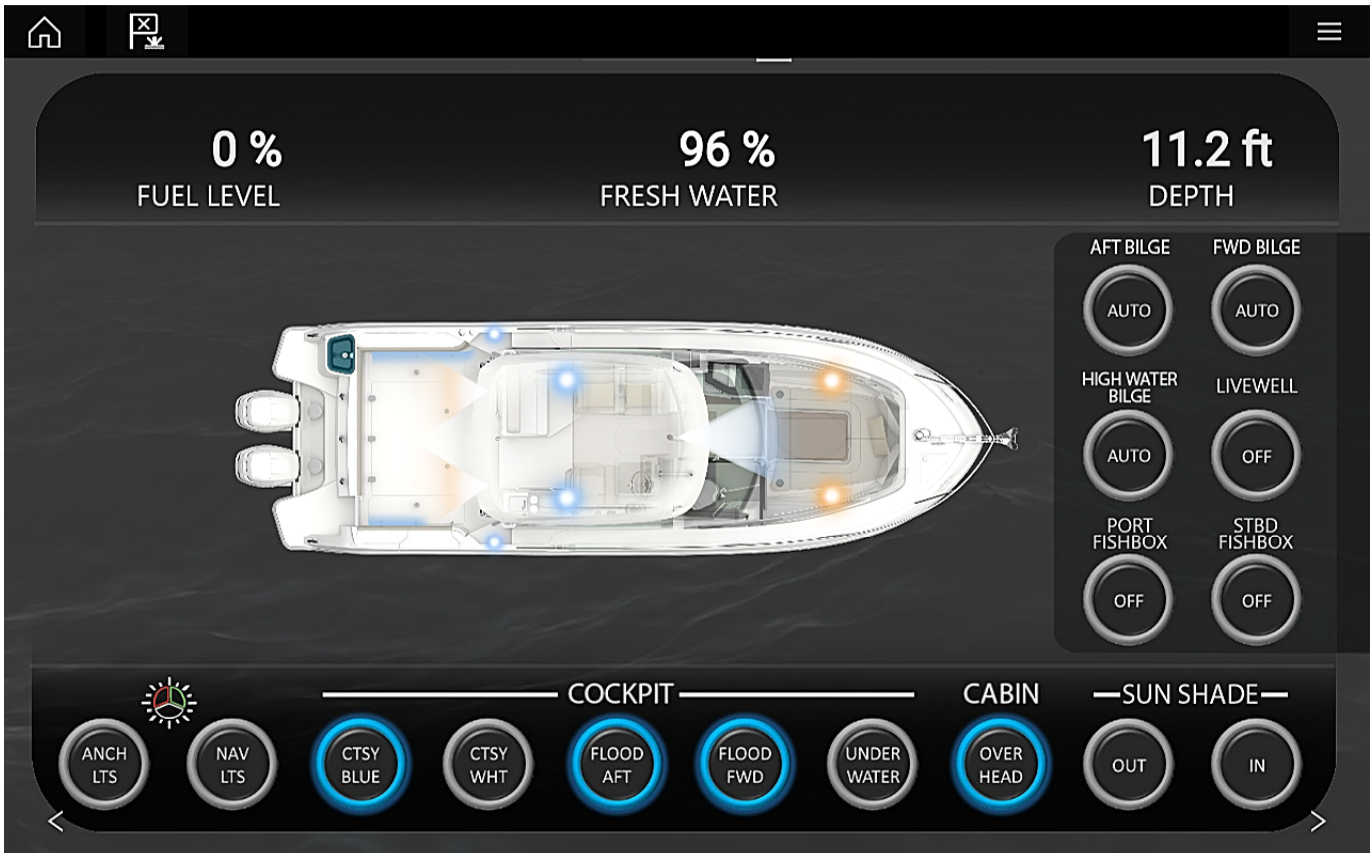

C-ZONE Control 1 Module Channels

	Ch.No.	Input/output	Channel Name	Signal Type
E1	1	OUTPUT	Forward bilge pump	12 VDC
	2	OUTPUT	Aft bilge pump	12 VDC
	3	OUTPUT	High water bilge pump	12 VDC
	4	OUTPUT	Livewell pump	12 VDC
E2	1	OUTPUT	Deck courtesy light (white)	12 VDC
	2	OUTPUT	Deck courtesy light (blue)	12 VDC
	3	OUTPUT	Overhead cabin light	12 VDC
	4	OUTPUT	Underwater light	12 VDC
	5	OUTPUT	Underwater light	12 VDC
	6	OUTPUT	Port fishbox pump	12 VDC
	7	OUTPUT	Starboard fishbox pump	12 VDC
	8	OUTPUT	Livewell light (blue/red)	12 VDC
	9	OUTPUT	N/A	12 VDC
	10	OUTPUT	N/A	12 VDC
	11	OUTPUT	N/A	12 VDC
	12	OUTPUT	N/A	12 VDC
E3	1	INPUT	Livewell light switch	12 VDC
	2	INPUT	Cabin light switch	12 VDC
	3	INPUT	Horn switch	12 VDC
	4	INPUT	Fuel sender	12 VDC
	5	INPUT	Water sender	12 VDC
	6	INPUT	Key fob 1	12 VDC
	7	INPUT	Key fob 2	12 VDC
	8	INPUT	Key fob 3	12 VDC

C-ZONE OI Module Channels

Ch.No.	Input/output	Channel Name	Signal Type
1	OUTPUT	Navigation light	12 VDC
2	OUTPUT	Anchor light	12 VDC
3	OUTPUT	Map light	12 VDC
4	OUTPUT	Forward flood light	12 VDC
6	OUTPUT	Aft flood light	12 VDC

VesselView Interface

To access C-Zone system from VesselView display:

- Turn on engine battery switches and ignition keys
- The C-Zone digital switching interface screen turns on automatically.
- Press the *Control, Monitor* icon on the lower center of the screen.

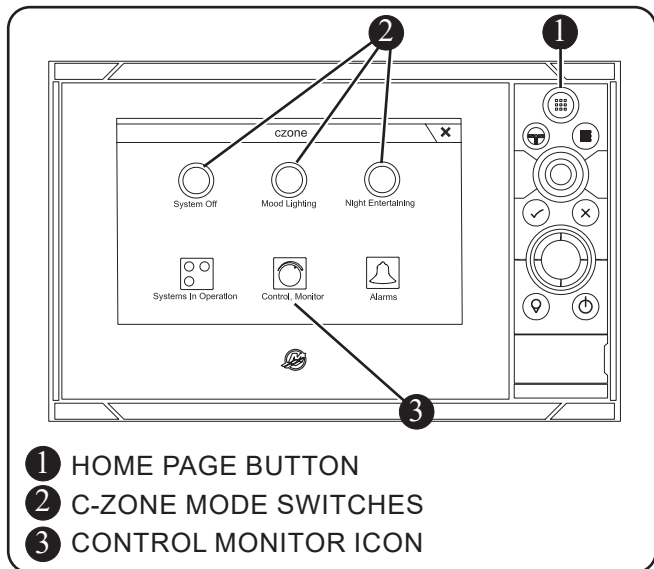

- To navigate back to the C-Zone interface, press the home page button at the top of VesselView control pad.
- Press the *C-Zone* tab in the sidebar to access the interface (see figure 4.20.1).

(FIGURE 4.20.1)



C-Zone Mode Switches:

There are three mode switches at the top of the VesselView interface screen including system off, mood lights, and night entertainment. To interface with systems on this vessel:

Select the system to monitor by touching the appropriate box.

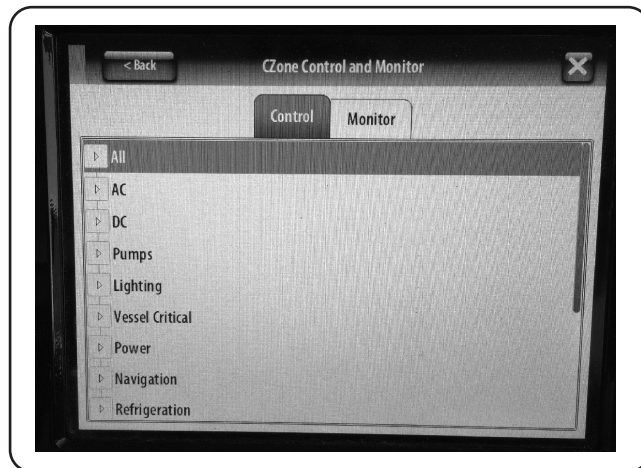

When the system is highlighted you are able to monitor and/or interface with the component. When on, the item is highlighted in green. When off, the item is highlighted in red.

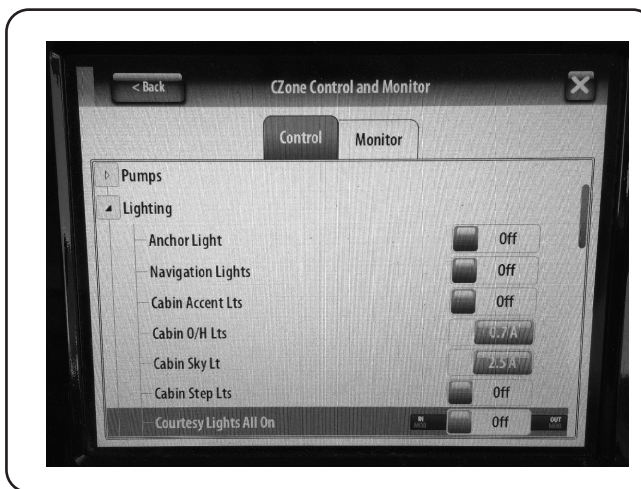

CAUTION

Do not update software on either the Raymarine Navigation System or the VesselView unit without first contacting your dealer or Boston Whaler. To do so will negatively impact your ability to access C-Zone Digital Switching.

Chapter 4 • Electrical

Wiring Identification Chart

Boston Whaler adheres to electrical wiring requirements that meet ABYC E-11 standards. The following table outlines the gauge, color and function of wiring used.

Wire Color Chart for DC and Special Circuit

COLOR	FUNCTION	COLOR	FUNCTION
RED	MAIN FEEDS/PORT 30 AMP RECEPTACLE, +12V MAIN, 12V RECEPTACLE	BRN/WHT	MACERATOR
BRN/BLK	STARBOARD FISHBOX PUMP	BRN/YEL	LIVEWELL PUMP
BRN/VIO	FORWARD FISHBOX PUMP	GRY	RUNNING LIGHTS
BRN/YEL	LIVEWELL PUMP (HIGH CURRENT)	GRY/BLK	ACC 1
BRN/BLU	PORT FISHBOX PUMP	GRY/BLU	ACC 2
BLK	GROUND	GRY/GRN	ACC 3
BLK/YEL	STOP CIRCUIT	GRY/RED	AFT MAST/ACC 4
BLK/WHT	GEN SHUTDOWN	GRY/WHT	ALL ROUND/FWD MAST LIGHT
BLU	COMPASS	GRN	GROUNDING/BONDING
BLU/BLK	DOME LIGHT	ORN	REFRIGERATOR or CENTER WIPER, STARBOARD 30 AMP RECEPTACLE
BLU/GRN	SPREADER LIGHT	ORN/BLU	HORN
BLU/ORN	LIVEWELL LIGHT	ORN/BRN	STARBOARD WIPER PARK
BLU/RED	COURTESY LIGHTS	ORN/GRN	STARBOARD WIPER
BLU/VIO	CABIN LIGHTS	ORN/RED	PORT WIPER
BRN	BILGE PUMP (SWITCHED)	ORN/VIO	VACUUM PUMP
BRN/BLK	STARBOARD FISHBOX PUMP	ORN/WHT	CENTER WIPER
BRN/BLU	PORT FISHBOX PUMP	PINK	FUEL SENDER
BRN/GRY	RAW WATER	VIO	IGNITION
BRN/GRN	FRESH WATER	WHT	CO MONITOR/ELECTRIC TRIM TAB (SWITCHED)
BRN/ORN	SUMP PUMP	YLW	BLOWER/STEREO MEMORY
BRN/RED	BILGE PUMP (UNSWITCHED)	YLW/RED	START
BRN/VIO	FORWARD FISHBOX PUMP		

Electrical Schematics

The harnesses and schematics on the following pages are for reference and to be used by Boston Whaler service technicians. Boston Whaler reserves the right to change or update the electrical system on any model at any time without notice. In addition, Boston Whaler is not obligated to make any updates to units built prior to a change.

Battery Harness
(FIGURE 4.22.1)

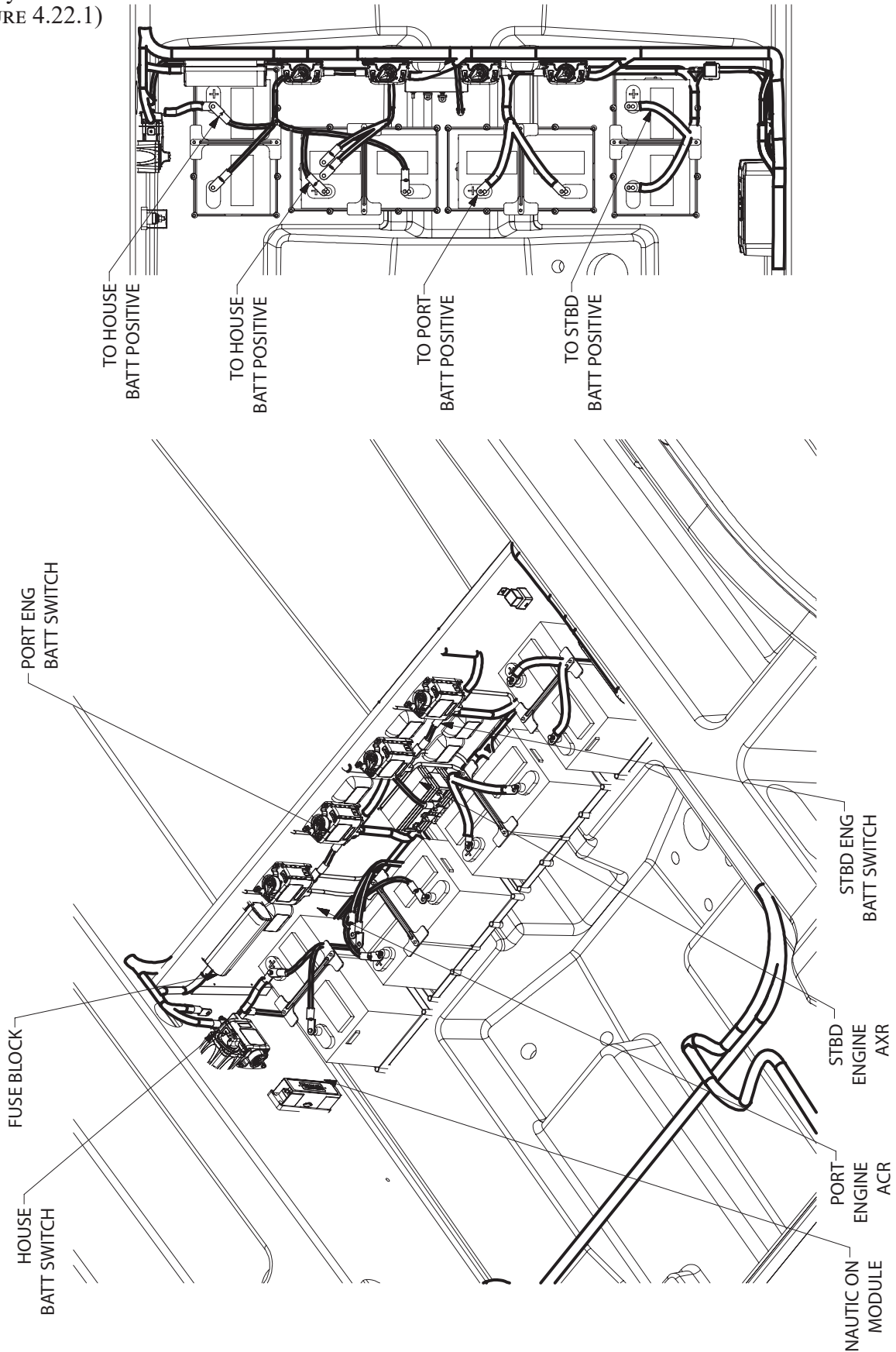

Bow Thruster Harness
(FIGURE 4.23.1)

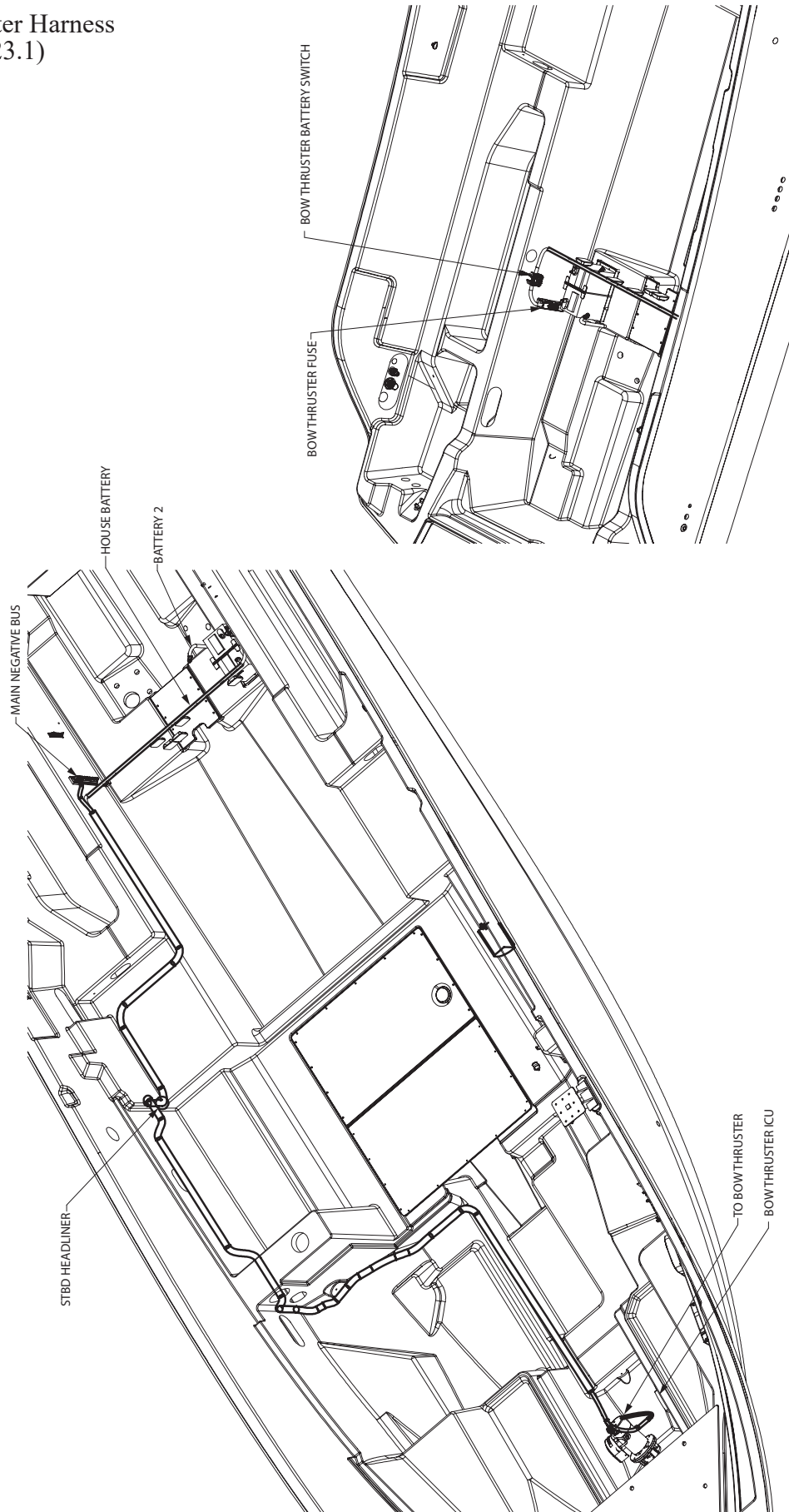

Hardtop Harness
(FIGURE 4.24.1)

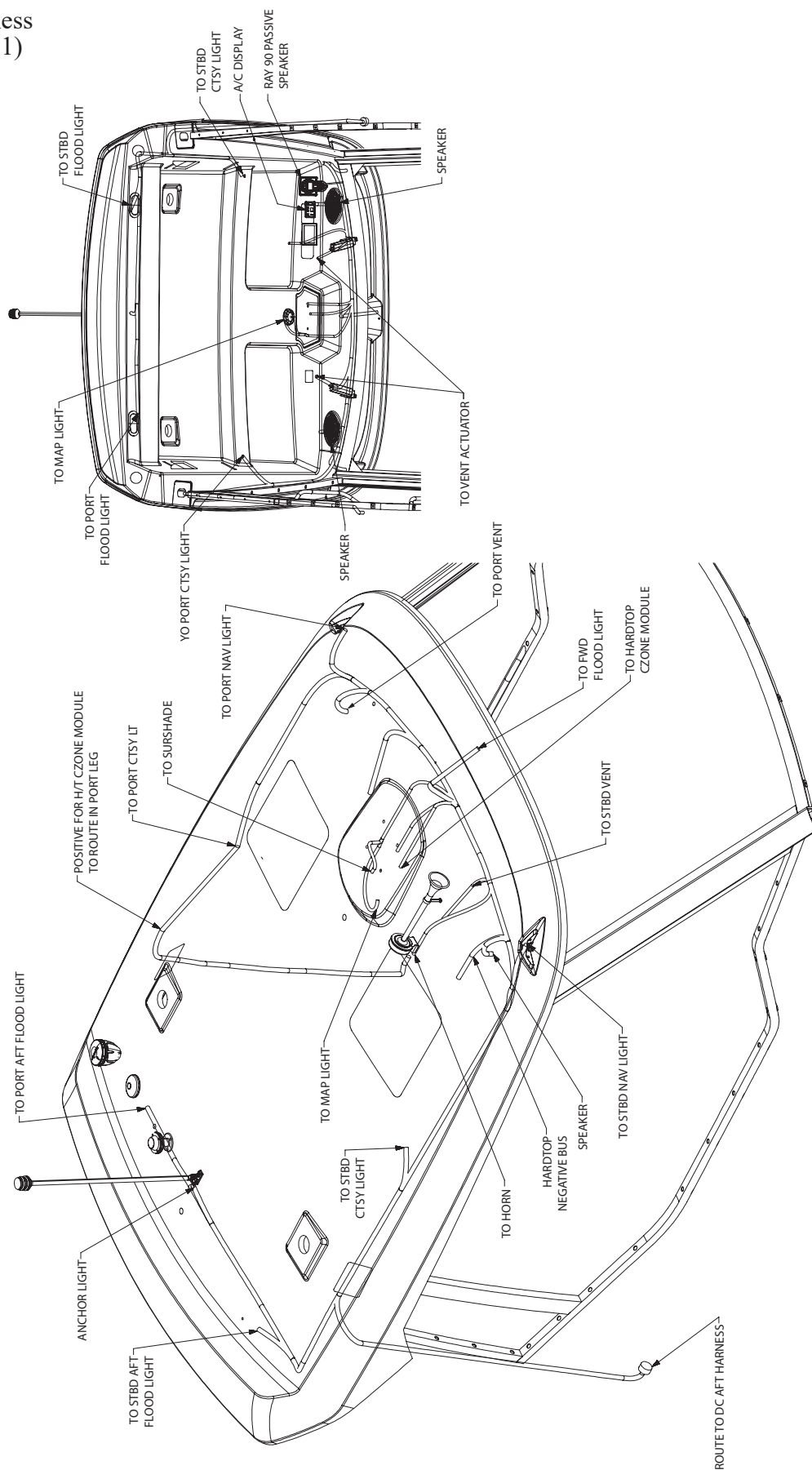

Headliner Harness
(FIGURE 4.25.1)

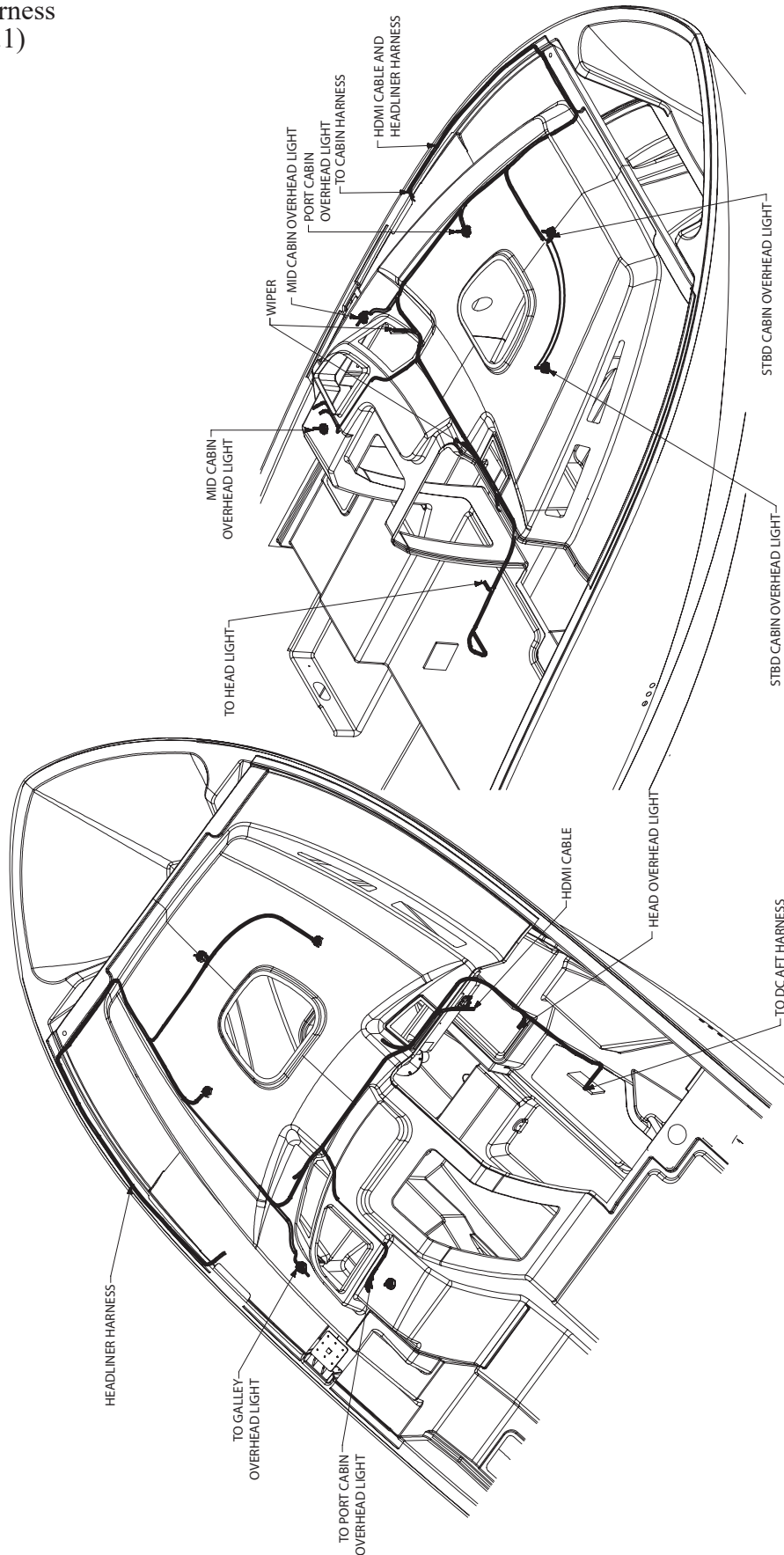

Port Side AC and DC Harness
(FIGURE 4.26.1)

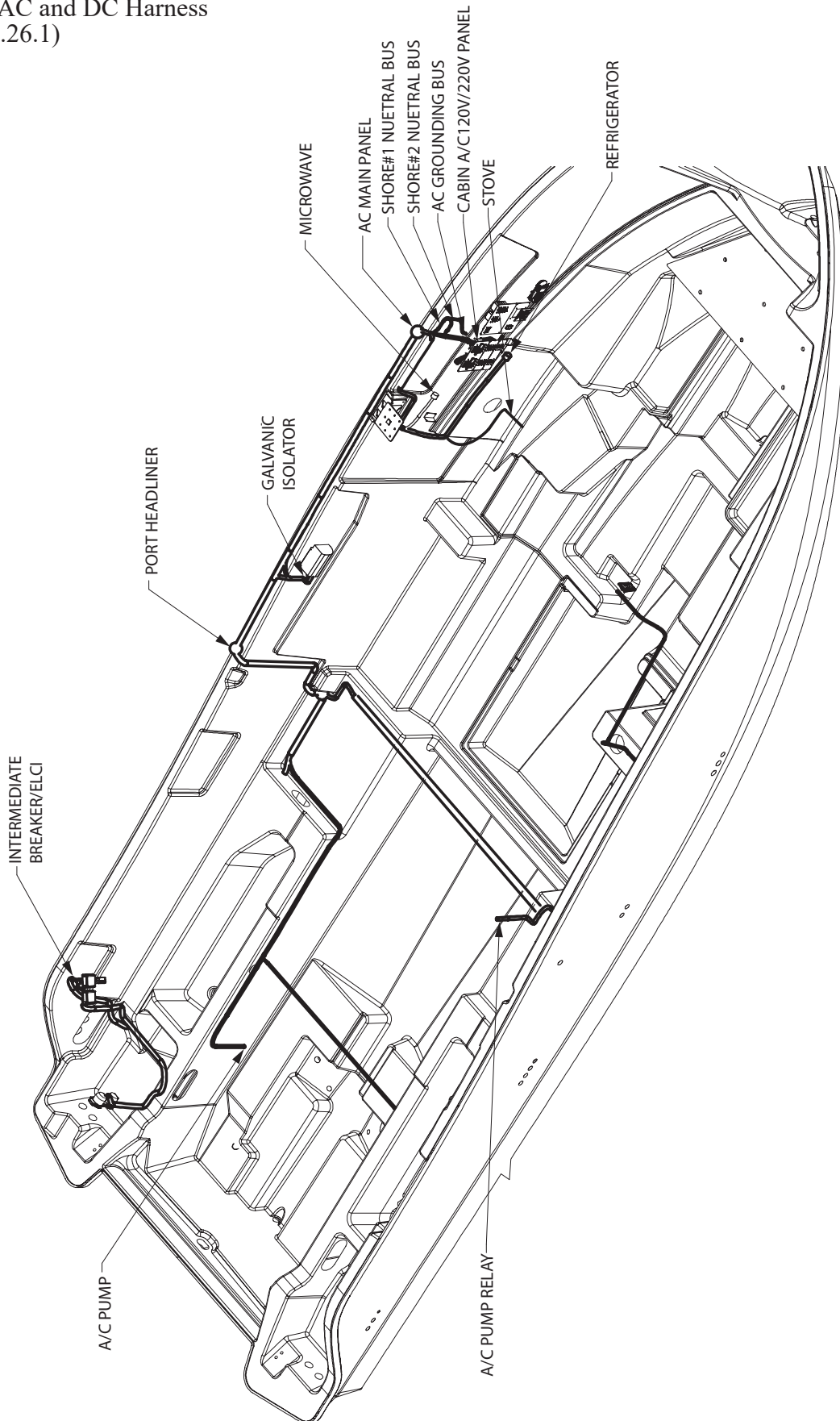

Starboard Side DC and AC Harness
(FIGURE 4.27.1)

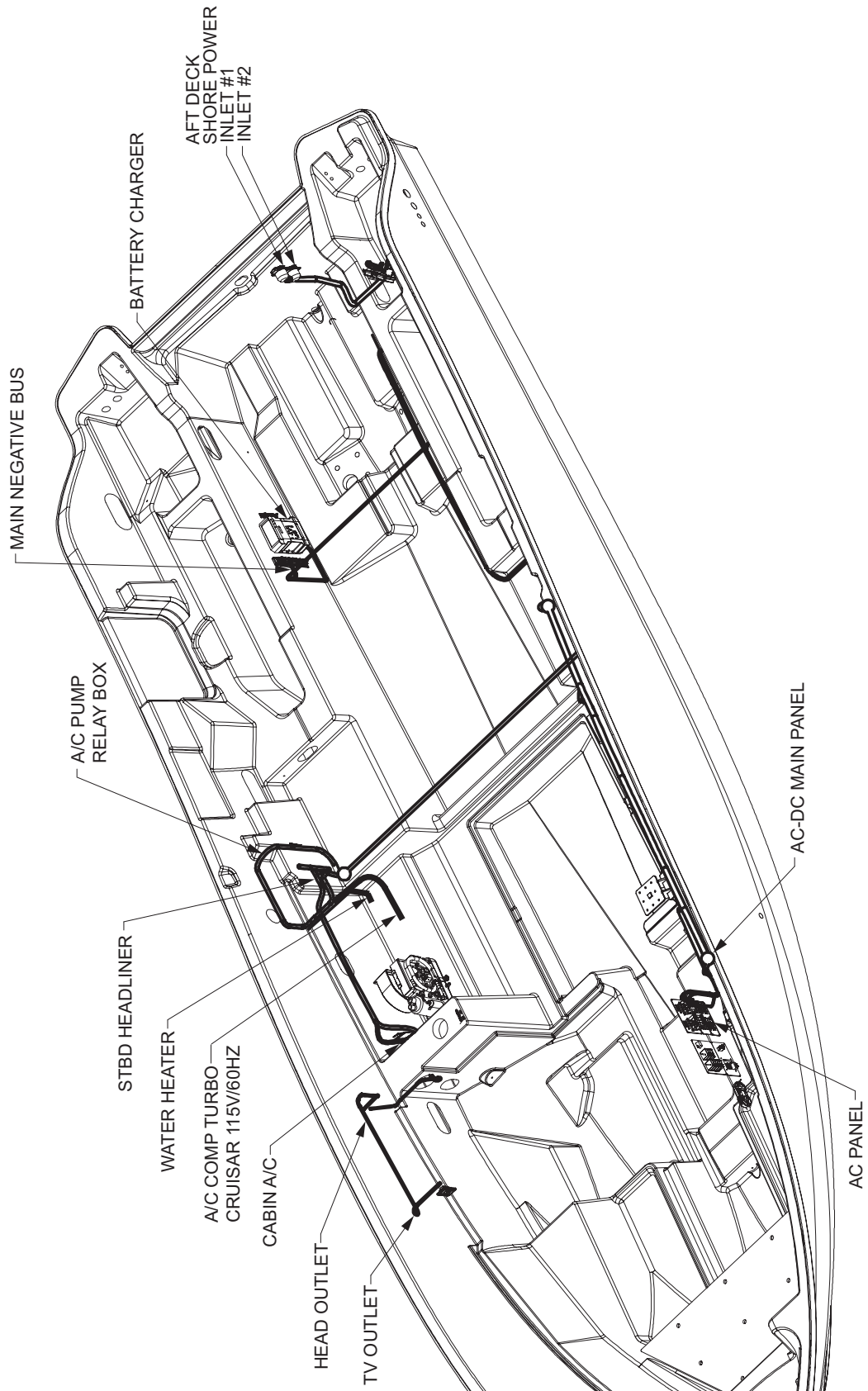

DC Aft Harness (page 1 of 4)
(FIGURE 4.28.1)

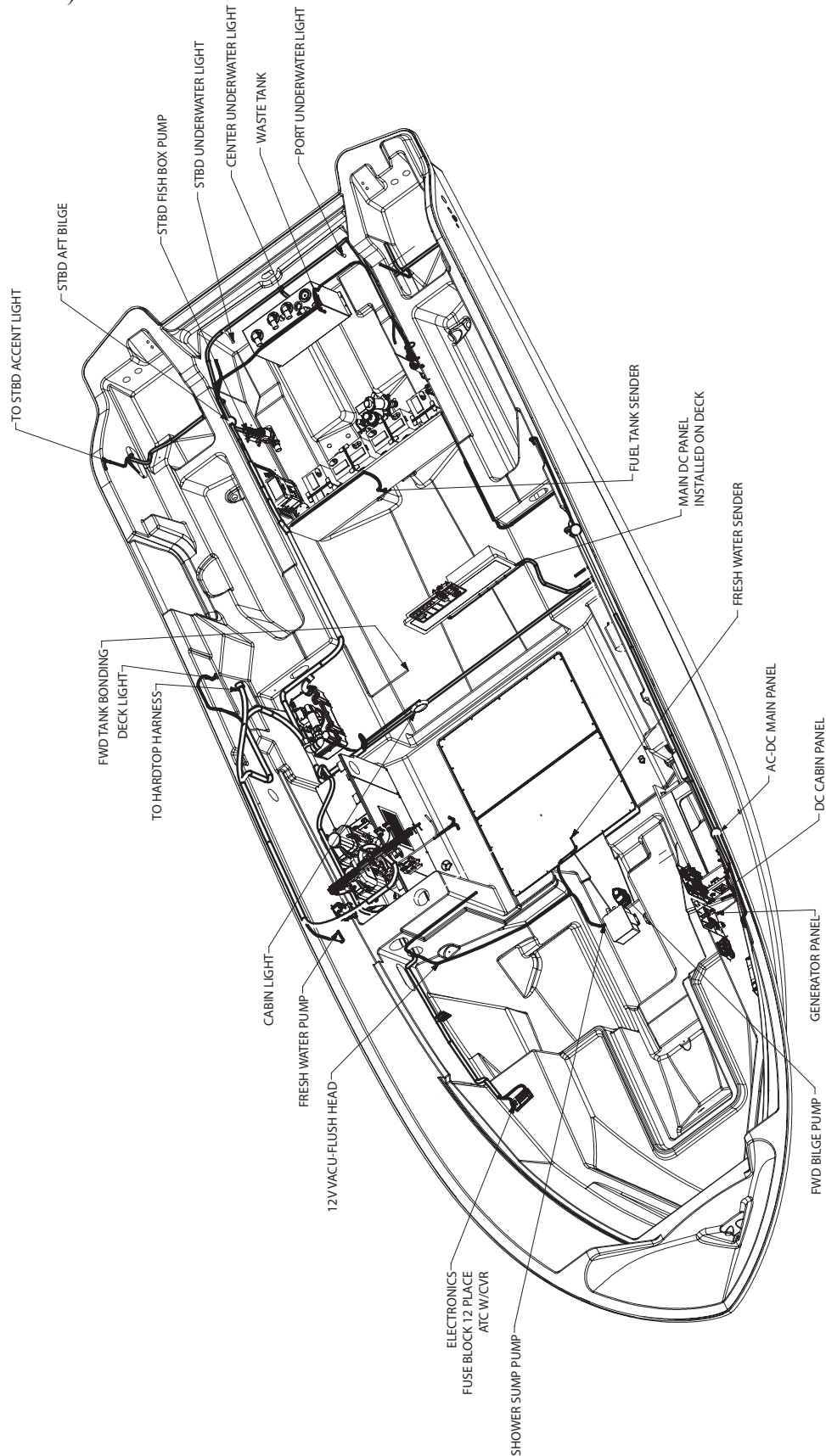

DC Aft Harness (page 2 of 4)
(FIGURE 4.29.1)

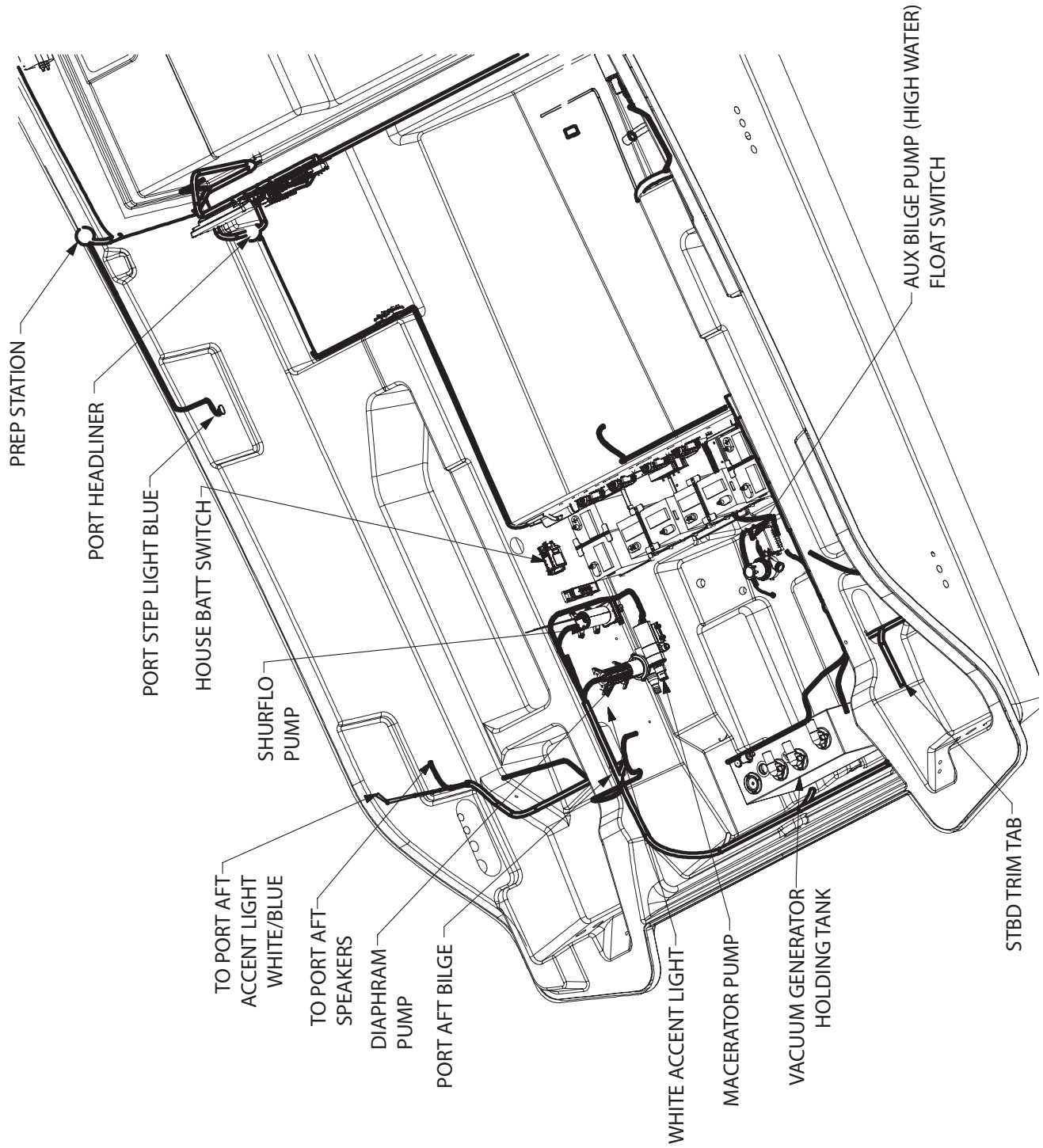

DC Aft Harness (page 3 of 4)
(FIGURE 4.30.1)

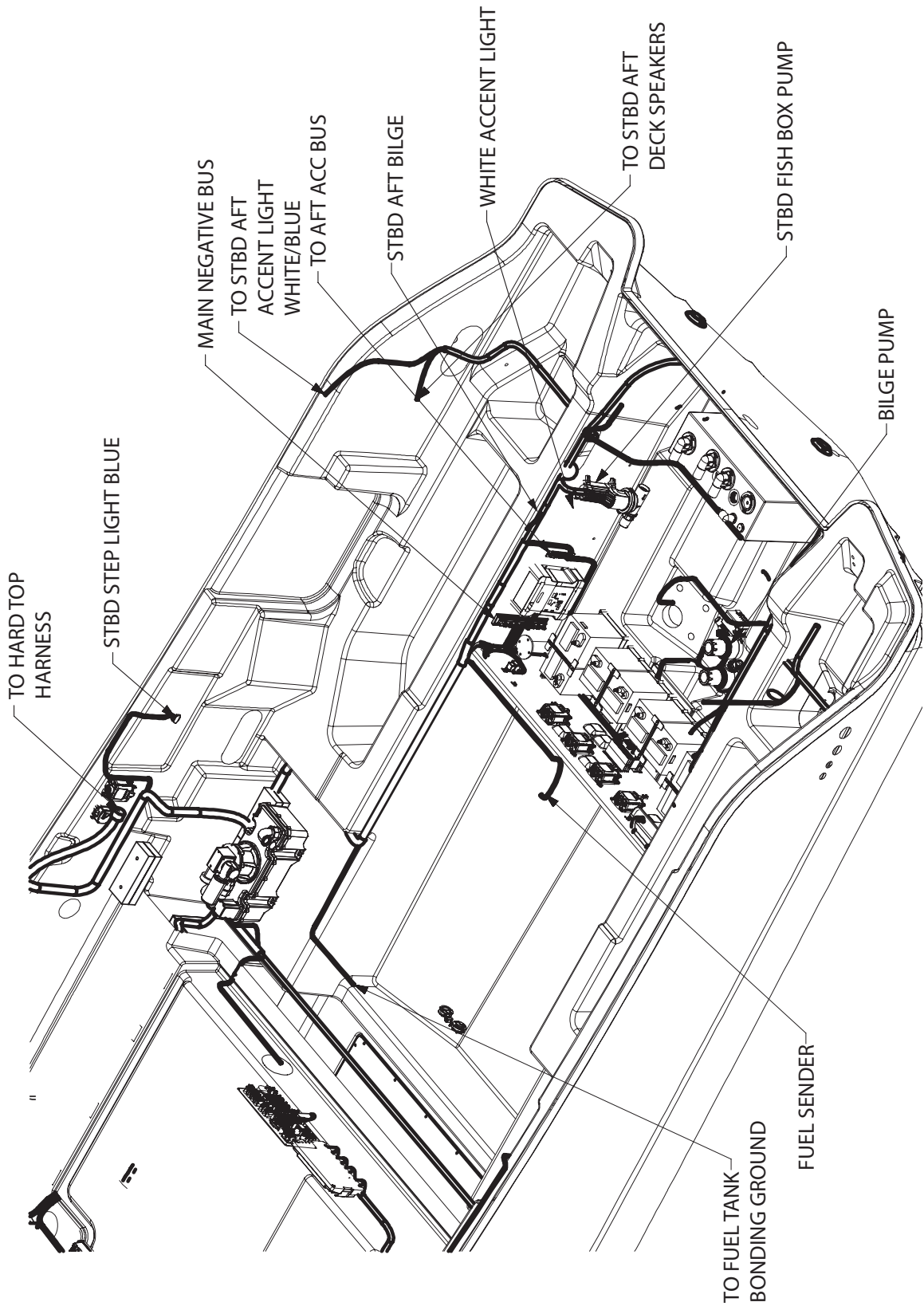

Chapter 4 • Electrical

DC Aft Harness (page 4 of 4)
(FIGURE 4.31.1)

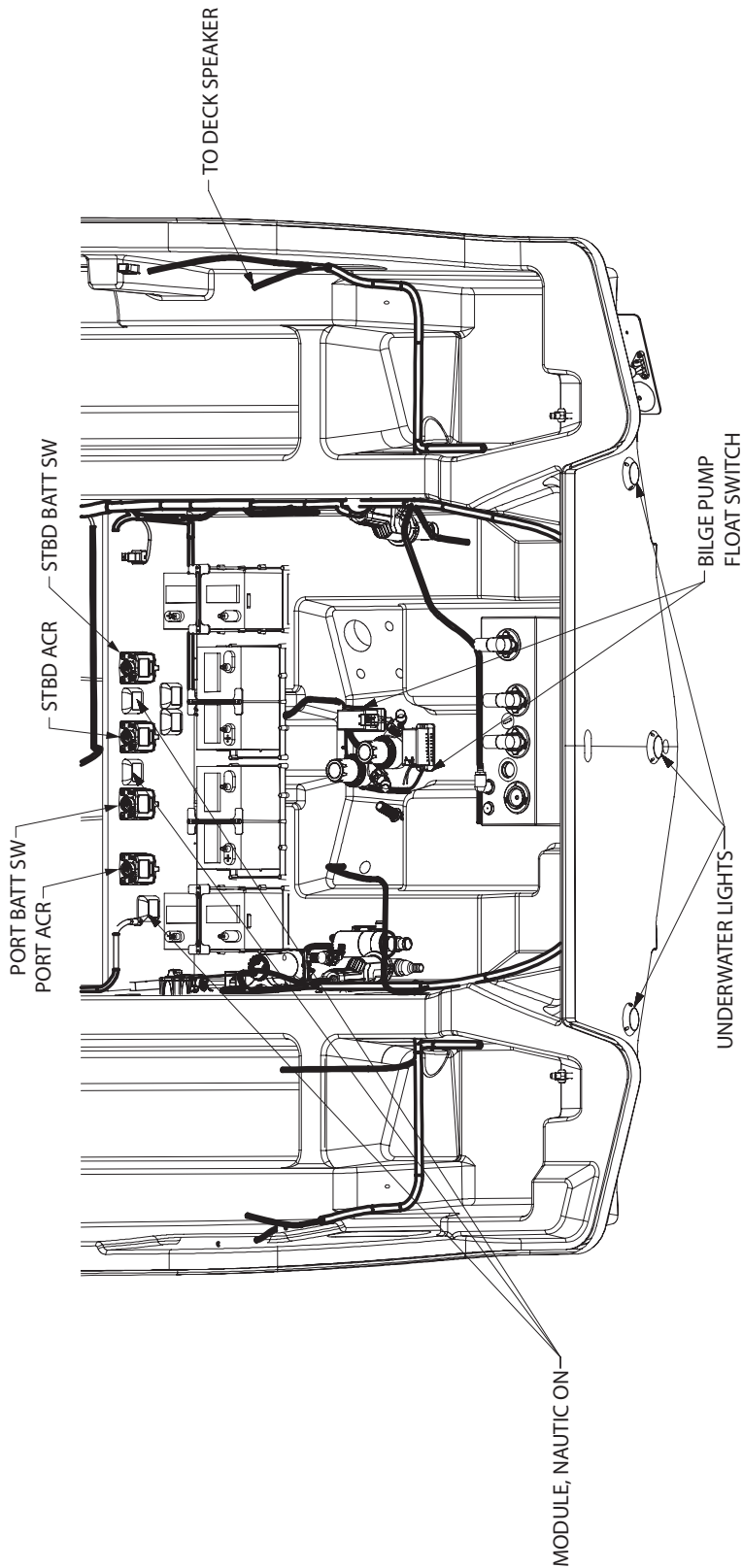

Windlass Harness (page 1 of 2)
(FIGURE 4.32.1)

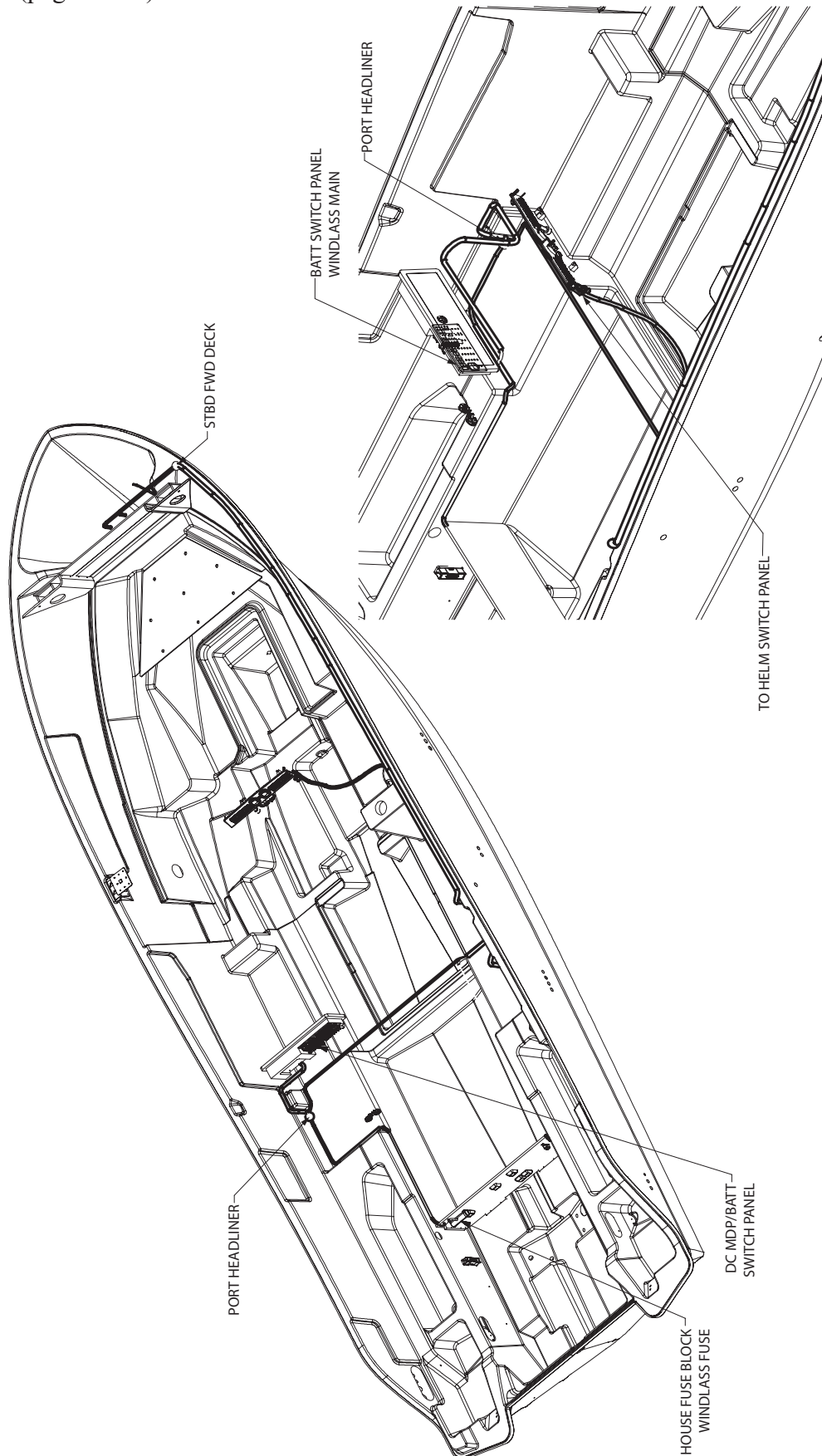

Windlass Harness (page 2 of 2)
(FIGURE 4.33.1)

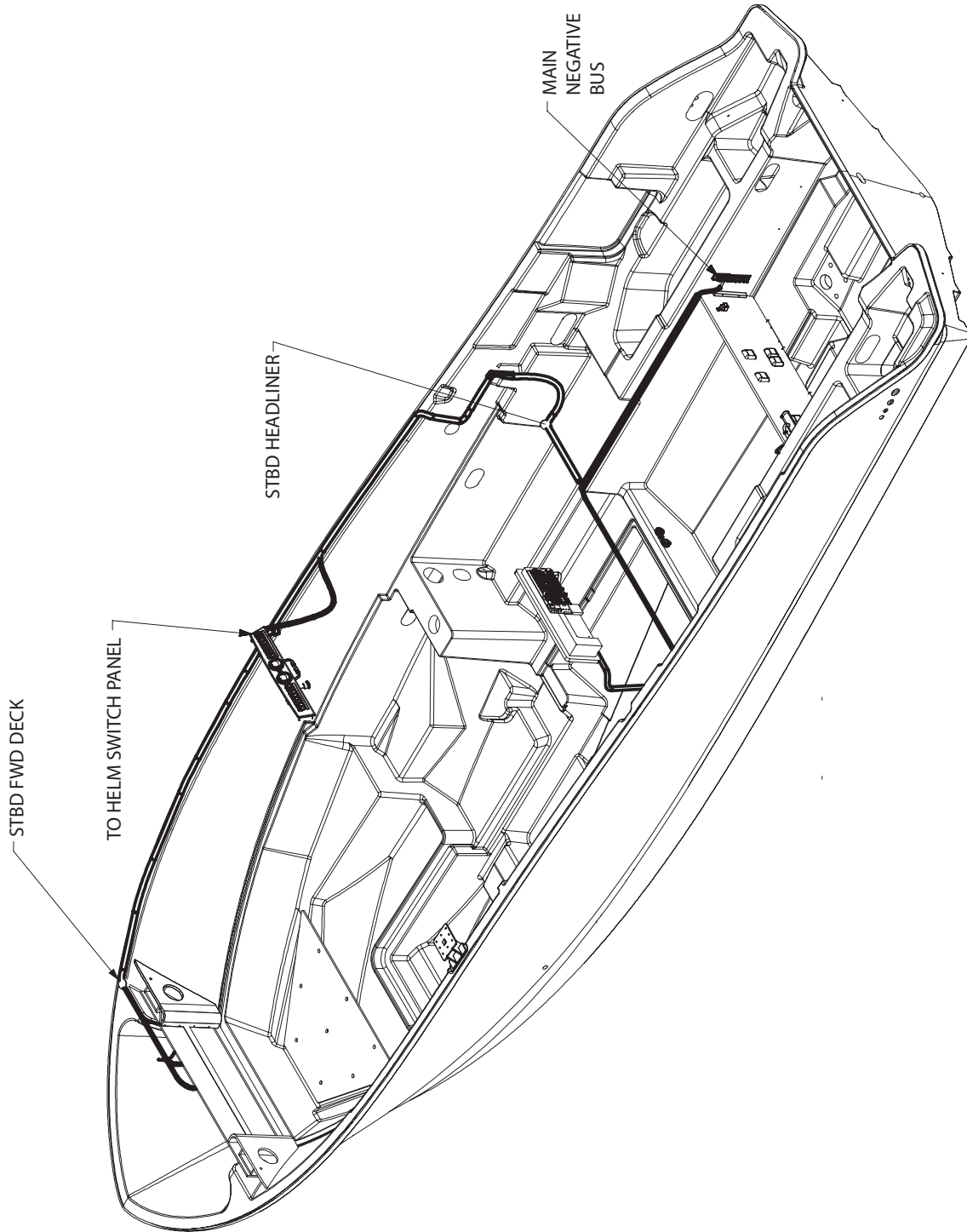

30 Amp Receptacles' Harness
(FIGURE 4.34.1)

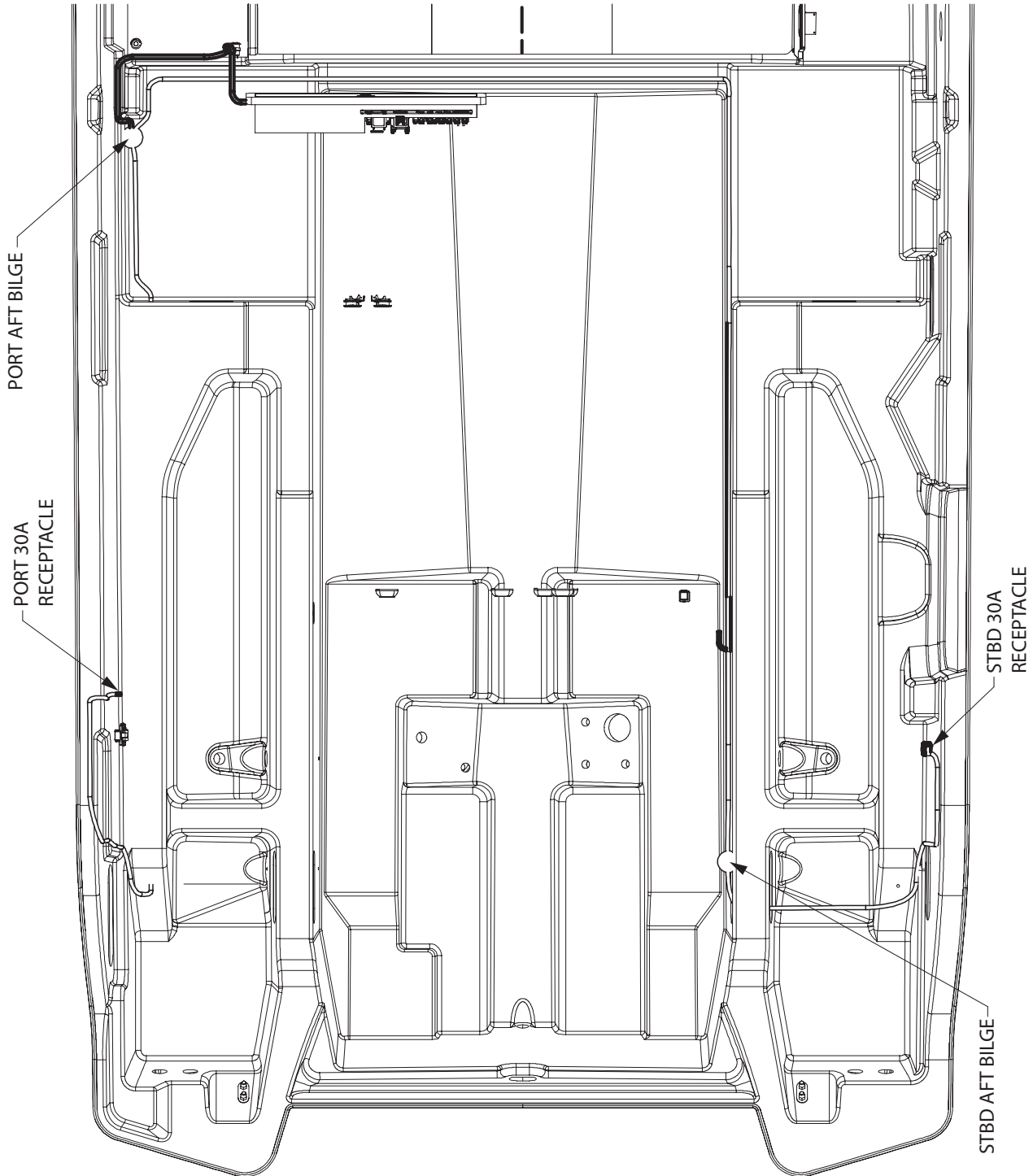

Chapter 4 • Electrical

Cabin Harness
(FIGURE 4.35.1)

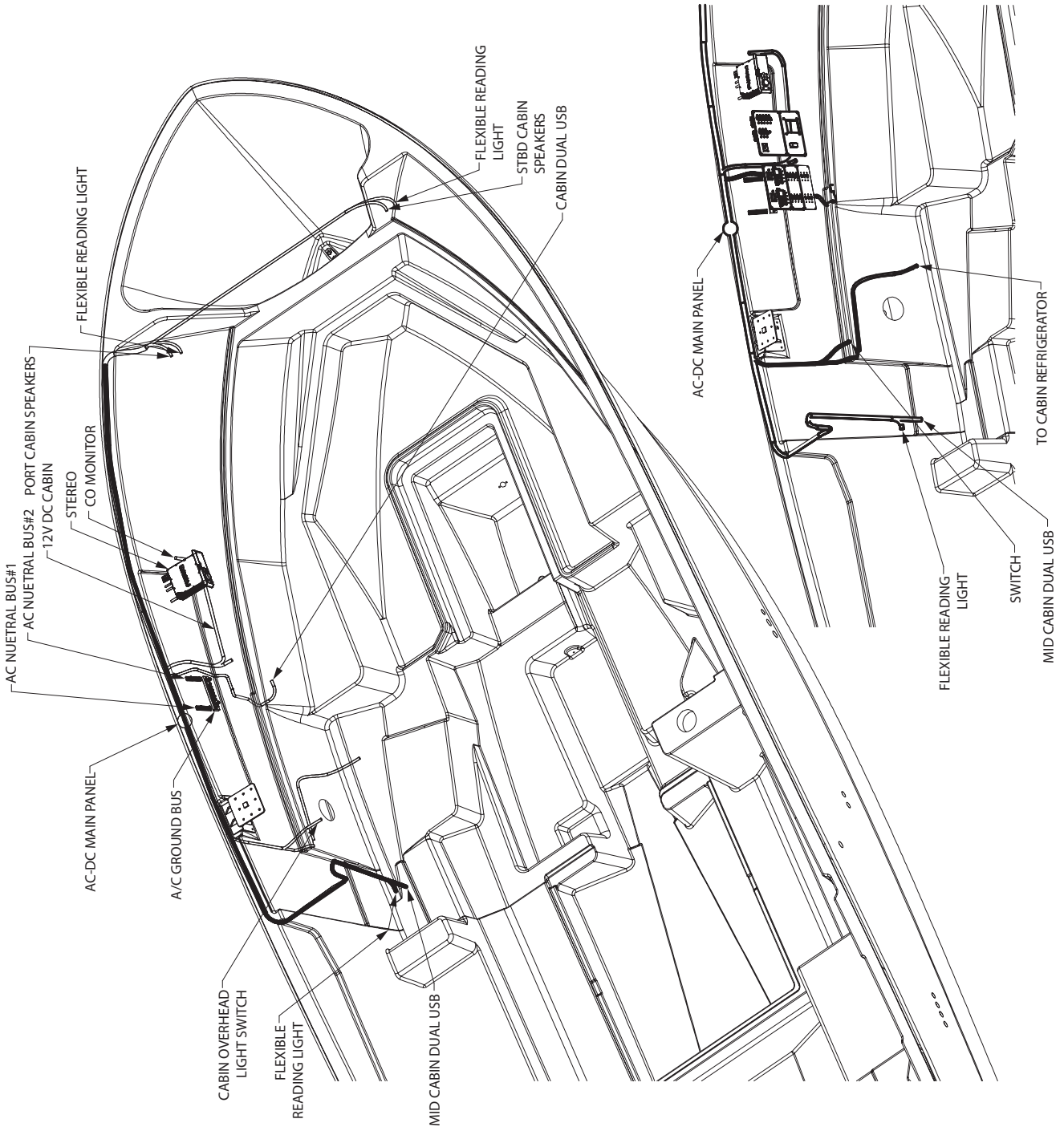

Grill Harness (page 1 of 2)
(FIGURE 4.36.1)

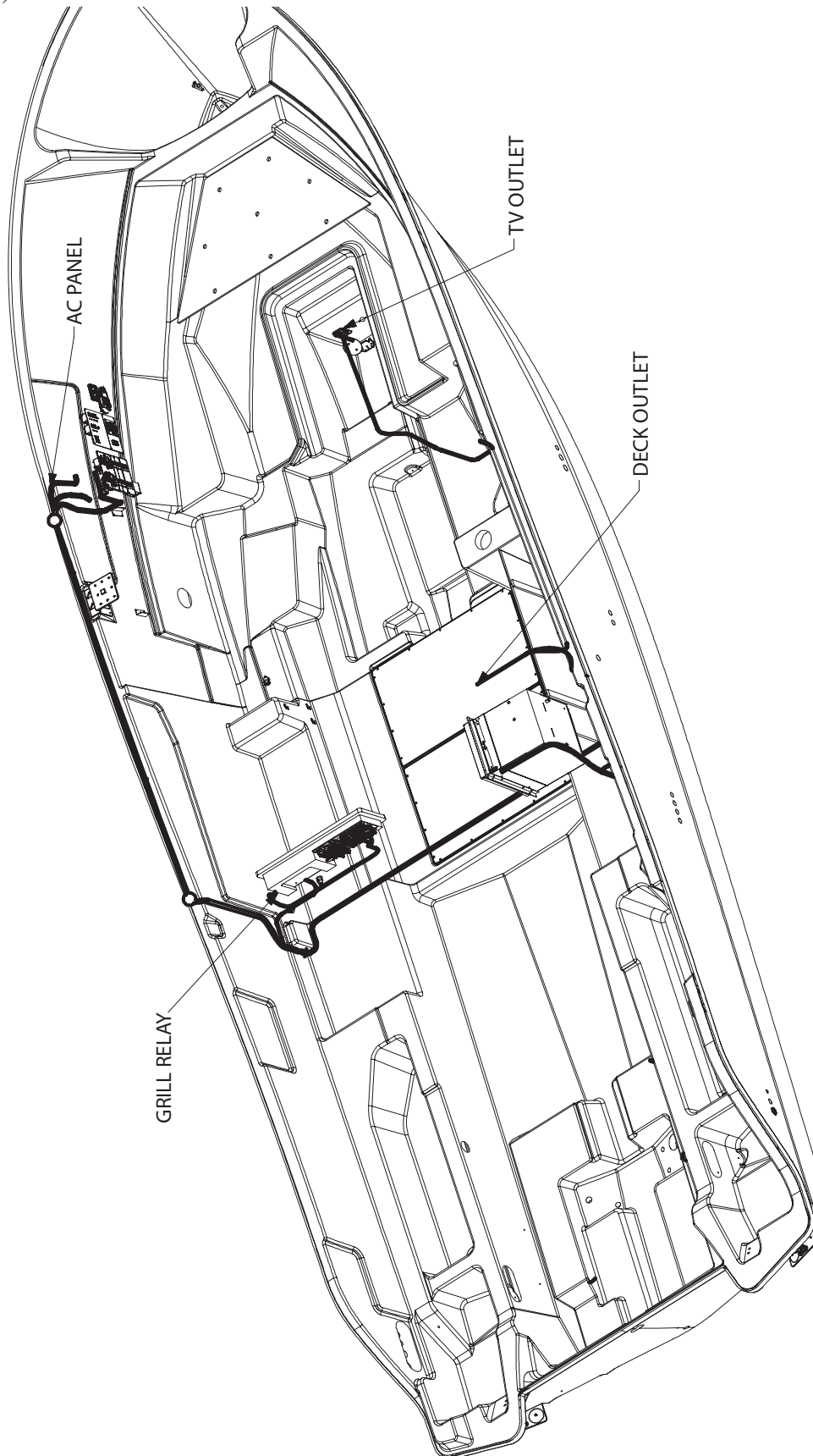

Chapter 4 • Electrical

Grill Harness (page 2 of 2)
(FIGURE 4.37.1)

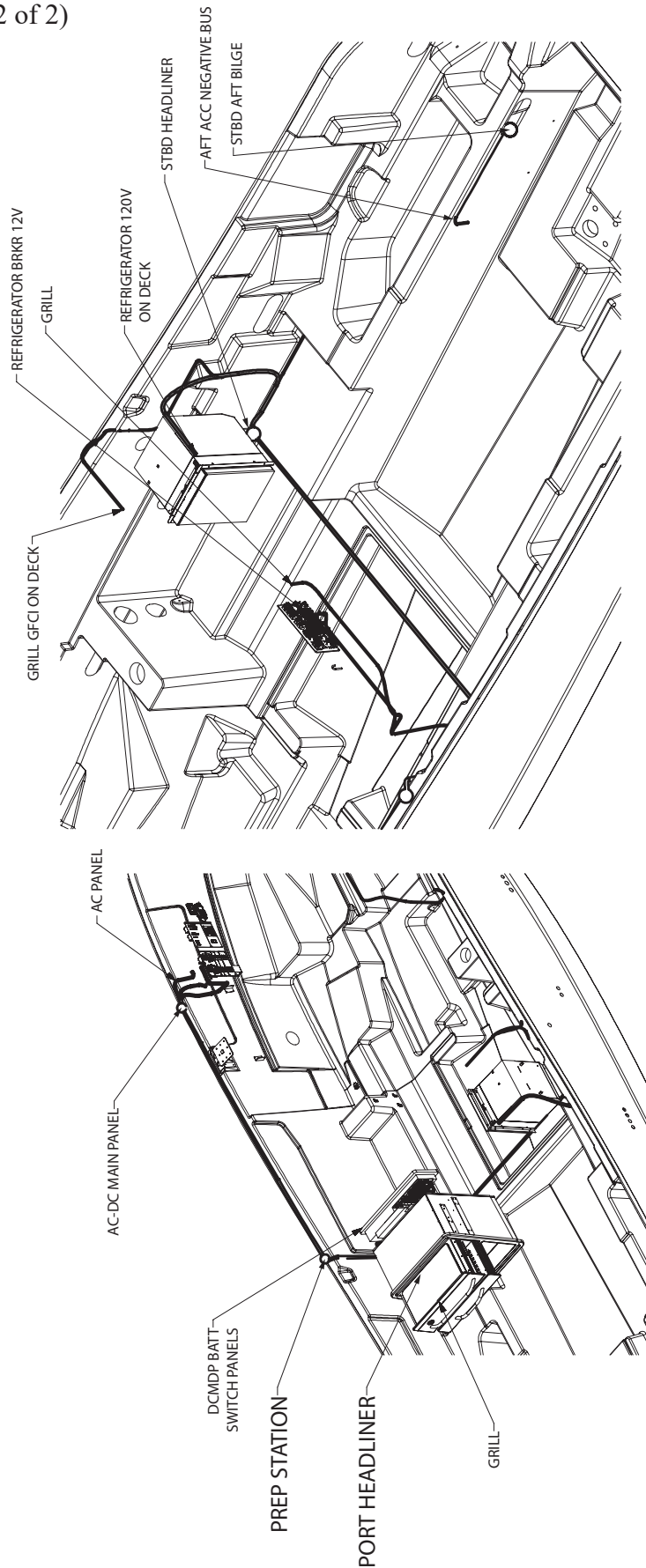

Generator Harness
(FIGURE 4.38.1)

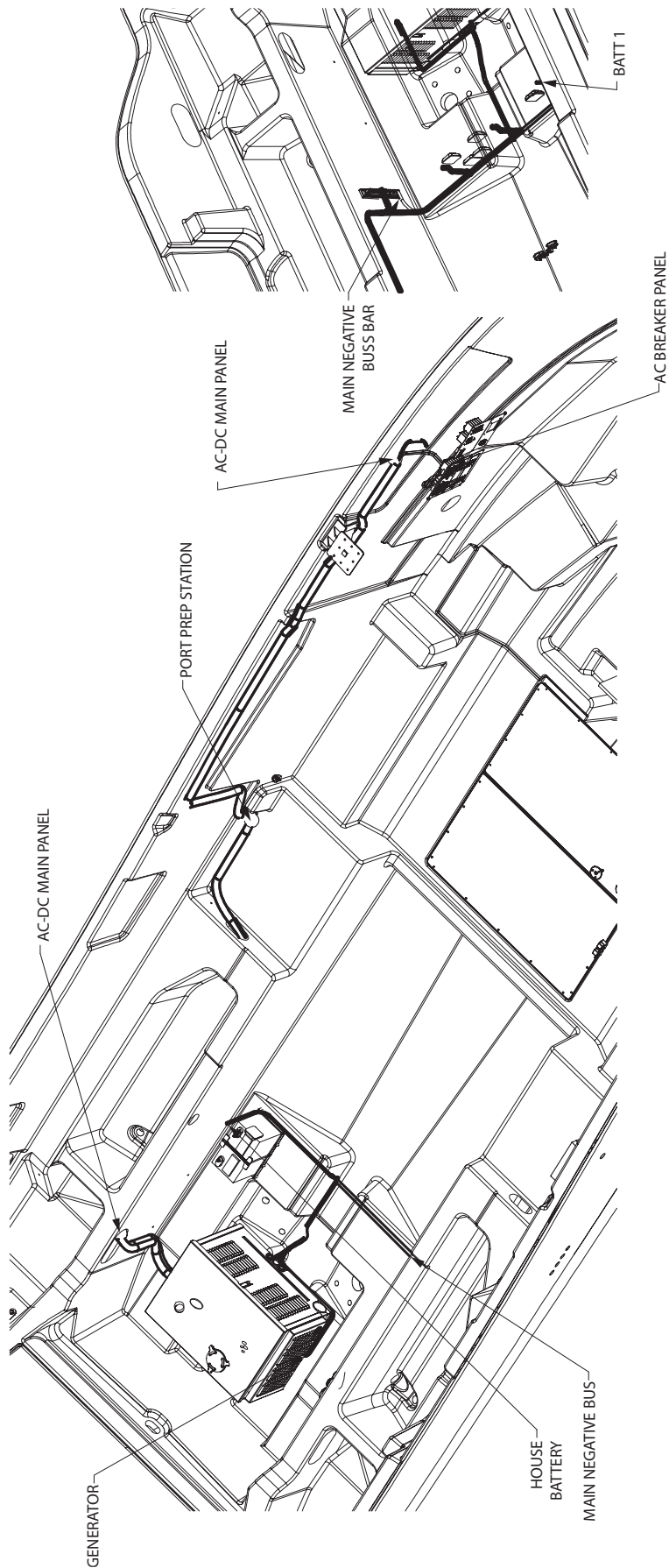

Gyroscopic Stabilizer Harness
(FIGURE 4.39.1)

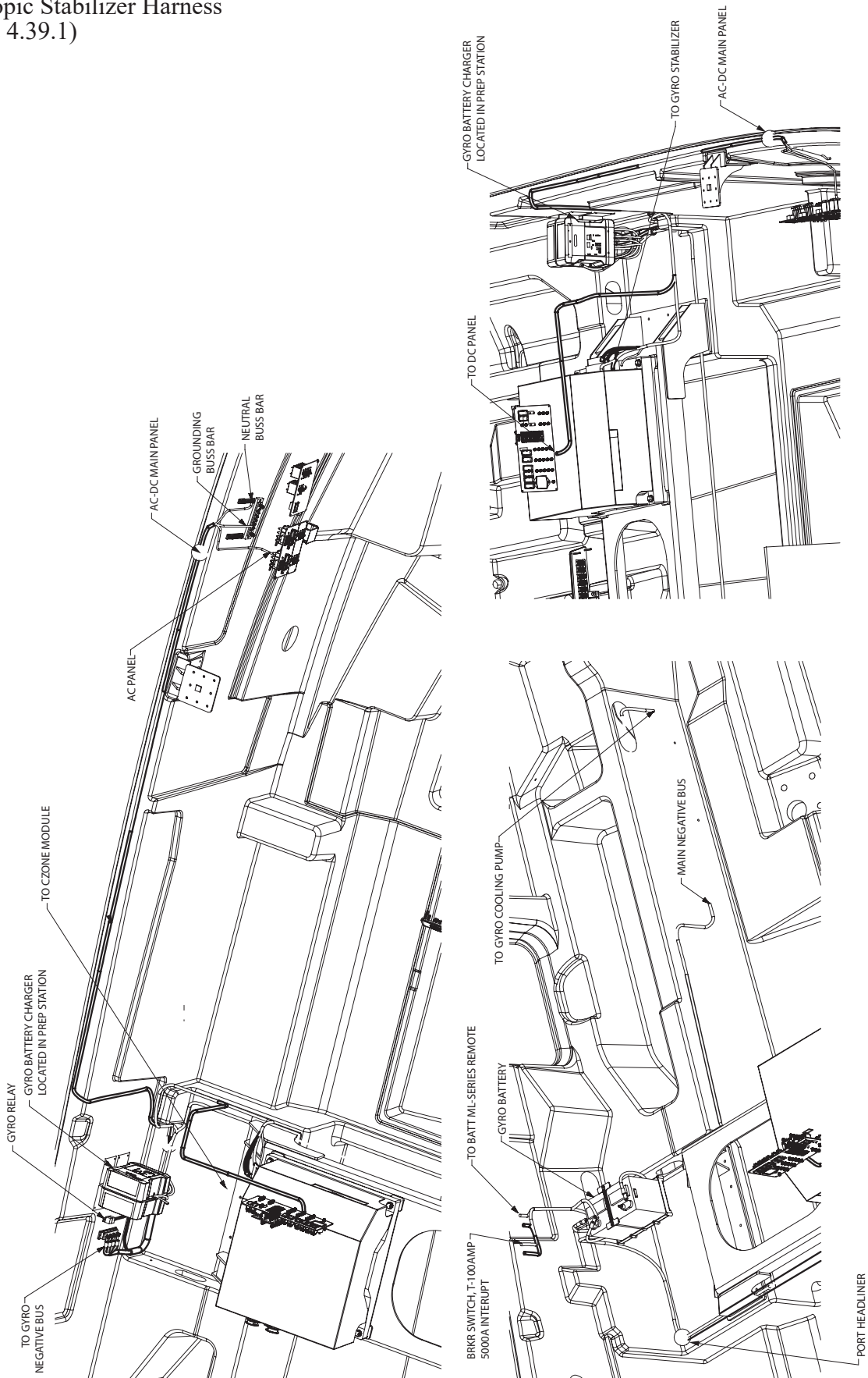

Main DC Battery RBS DC (joystick)
(FIGURE 4.40.1)

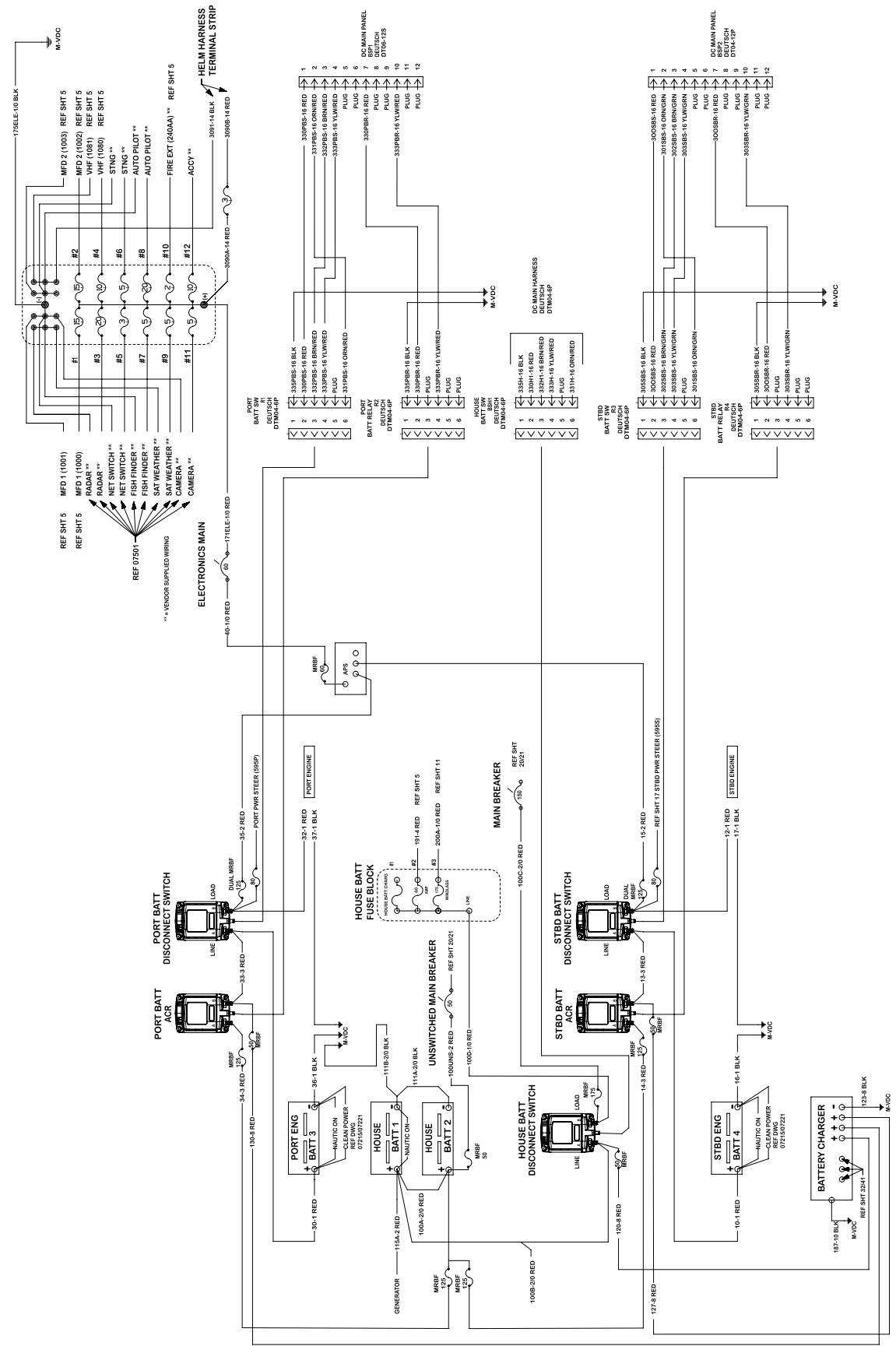

Main DC Battery RBS DC (standard)
(FIGURE 4.41.1)

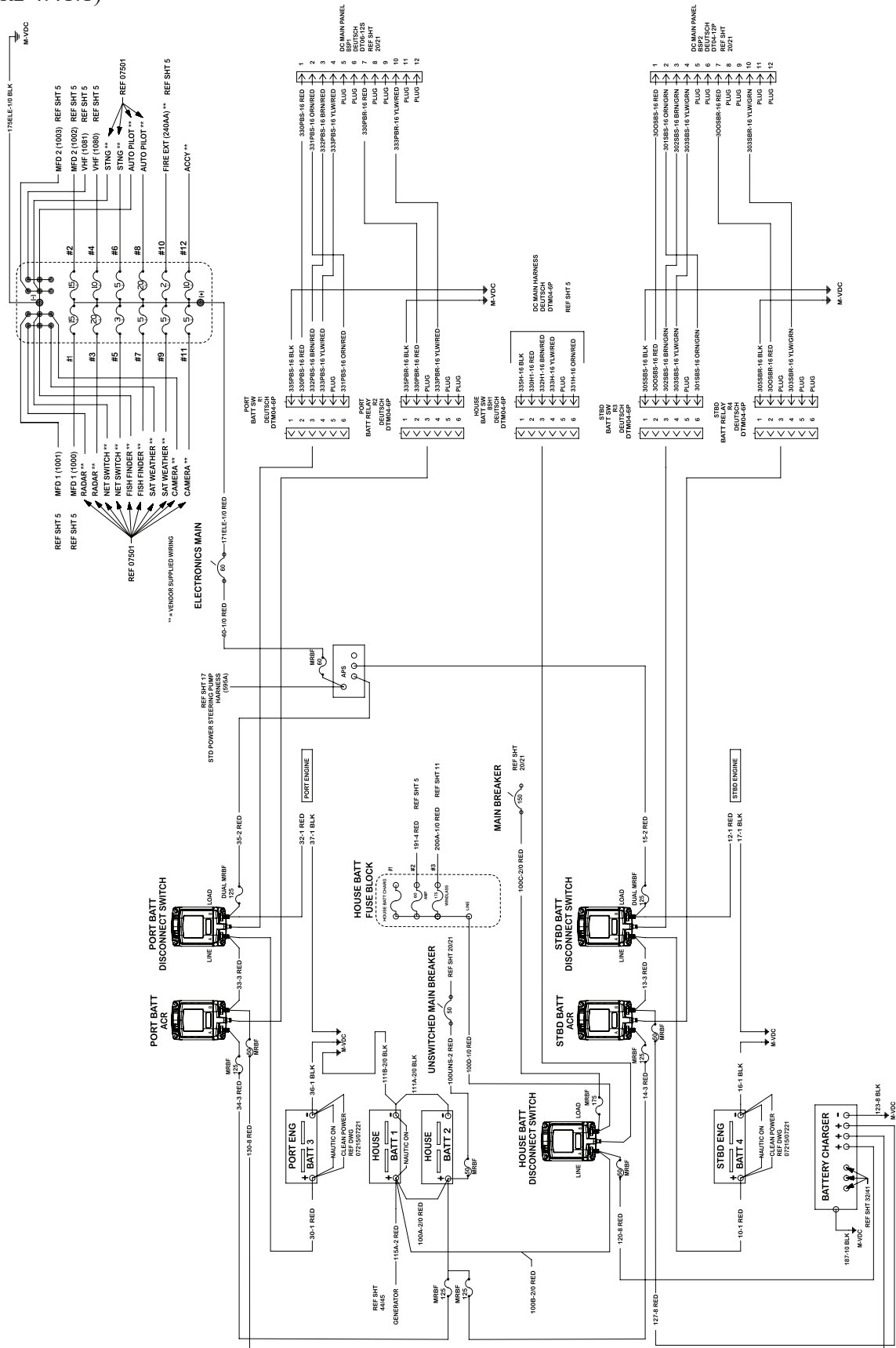

30A Receptacle and Spotlight Power Jumper
(FIGURE 4.42.1)

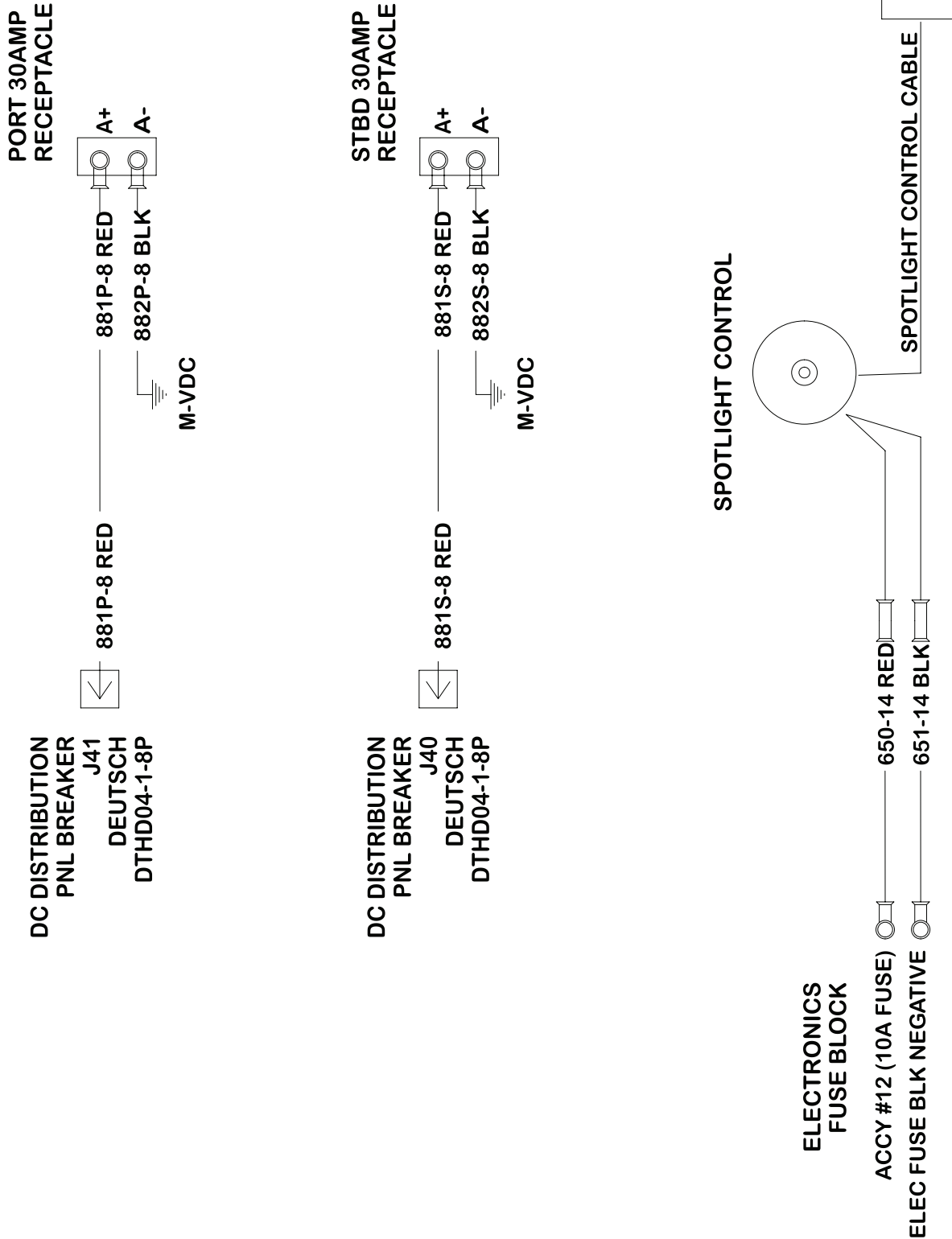

Bow Thruster DC
(FIGURE 4.43.1)

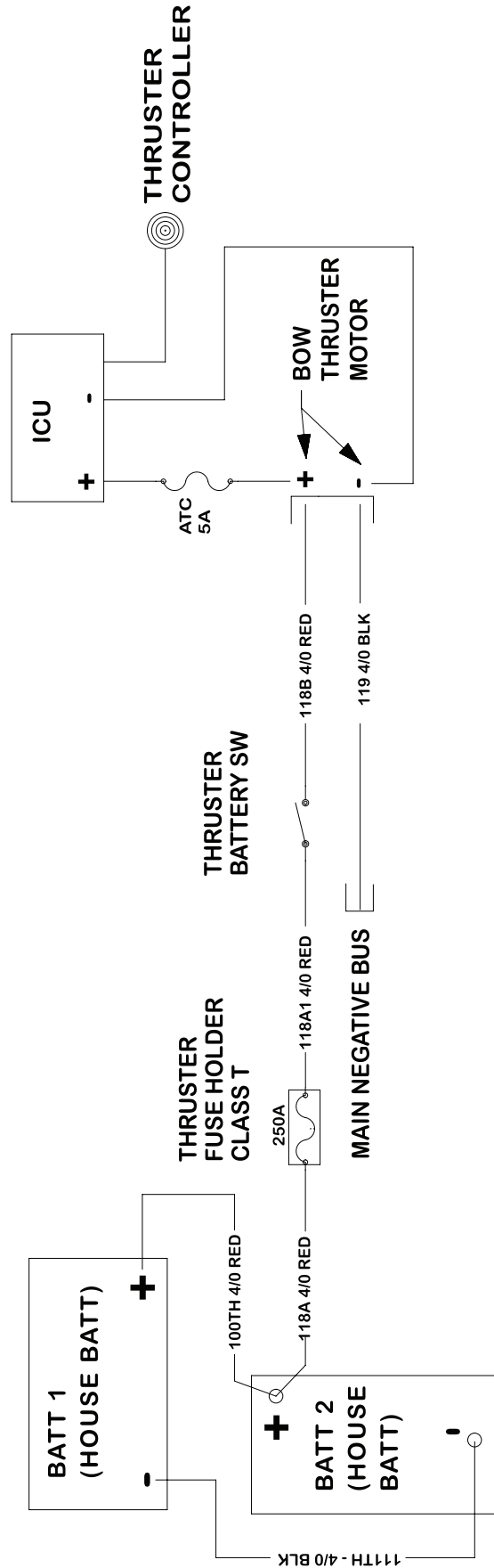

Main DC
(FIGURE 4.44.1)

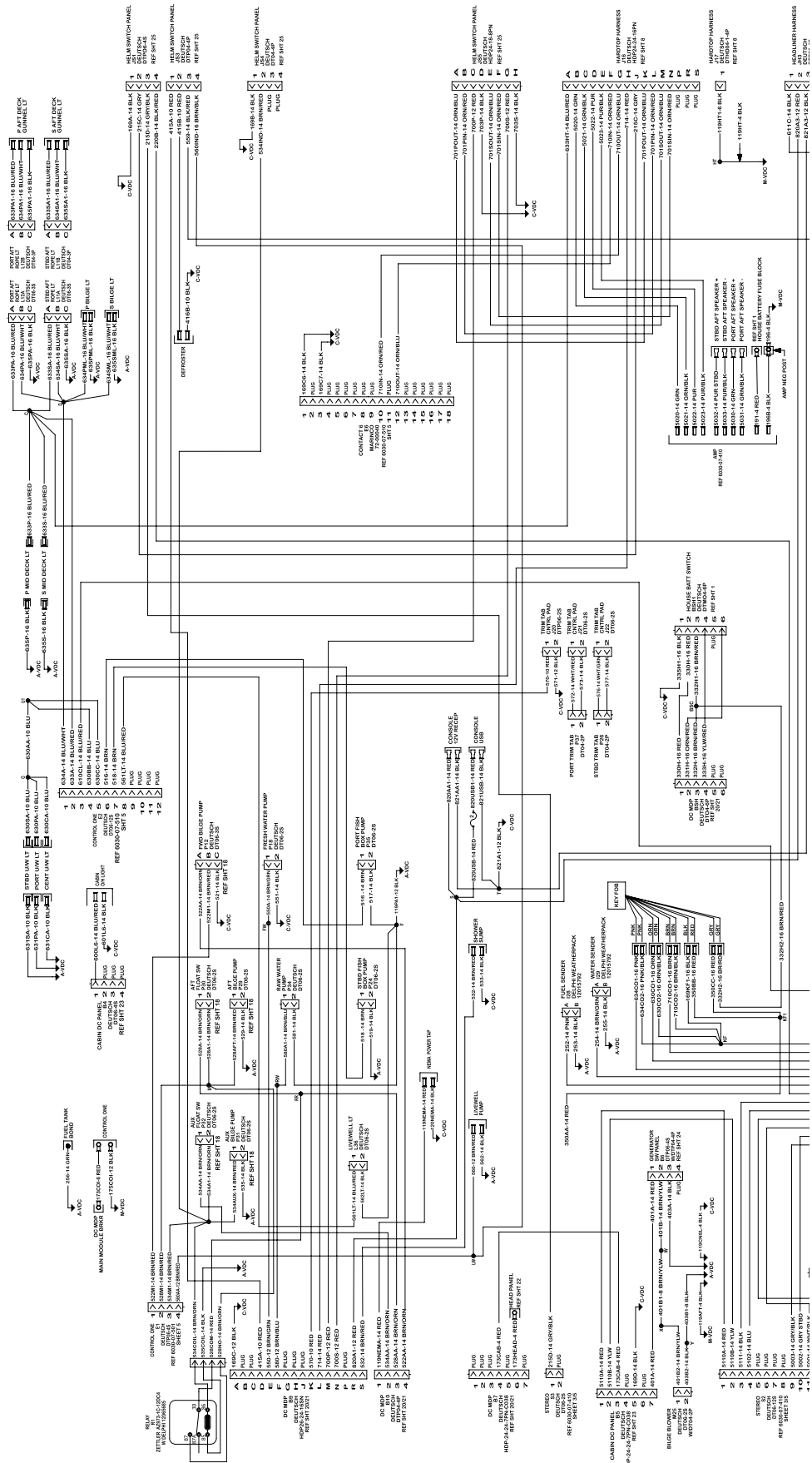

DC Battery Layout
(FIGURE 4.45.1)

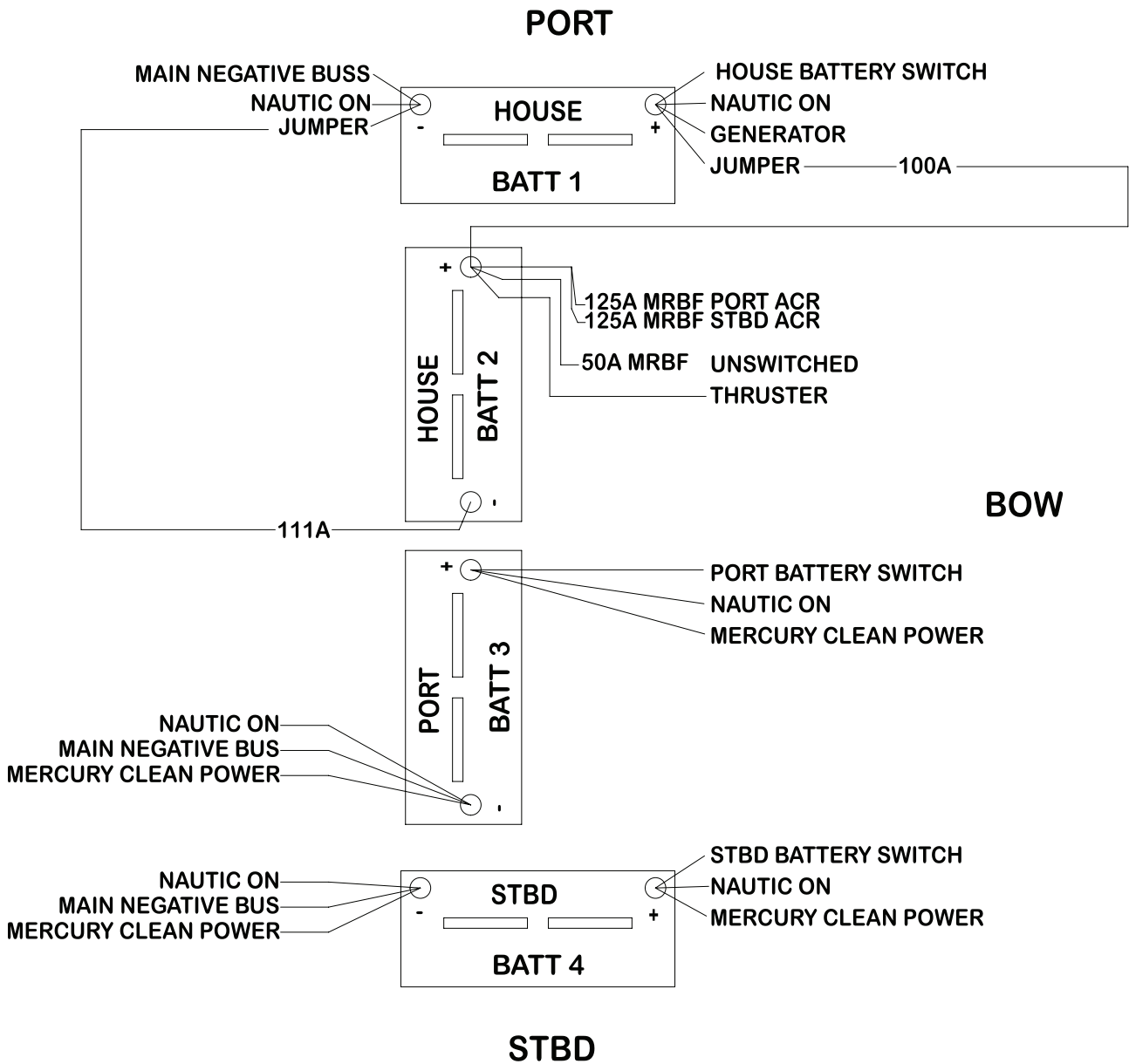

Headliner DC
(FIGURE 4.46.1)

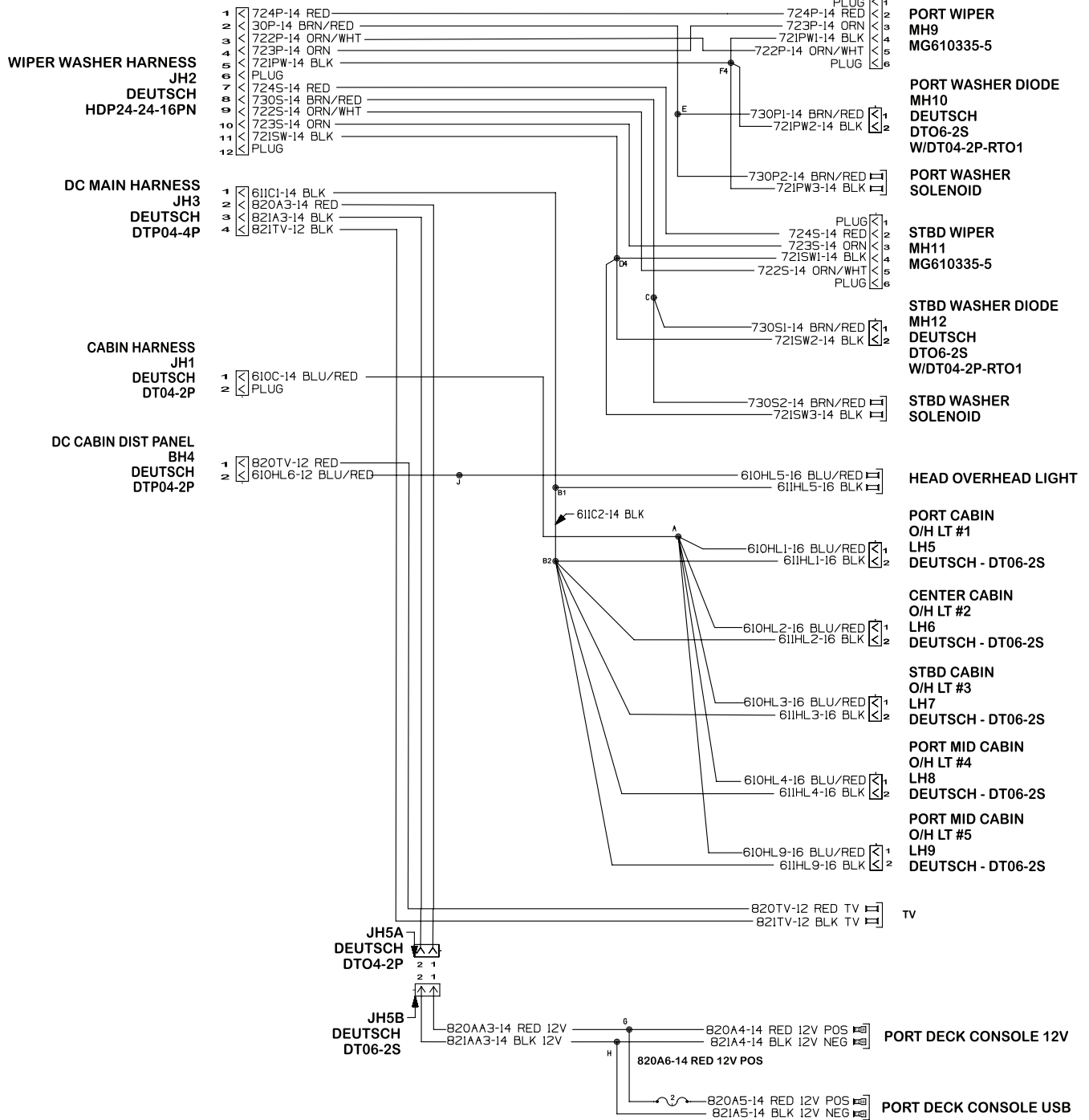

Hardtop DC
(FIGURE 4.47.1)

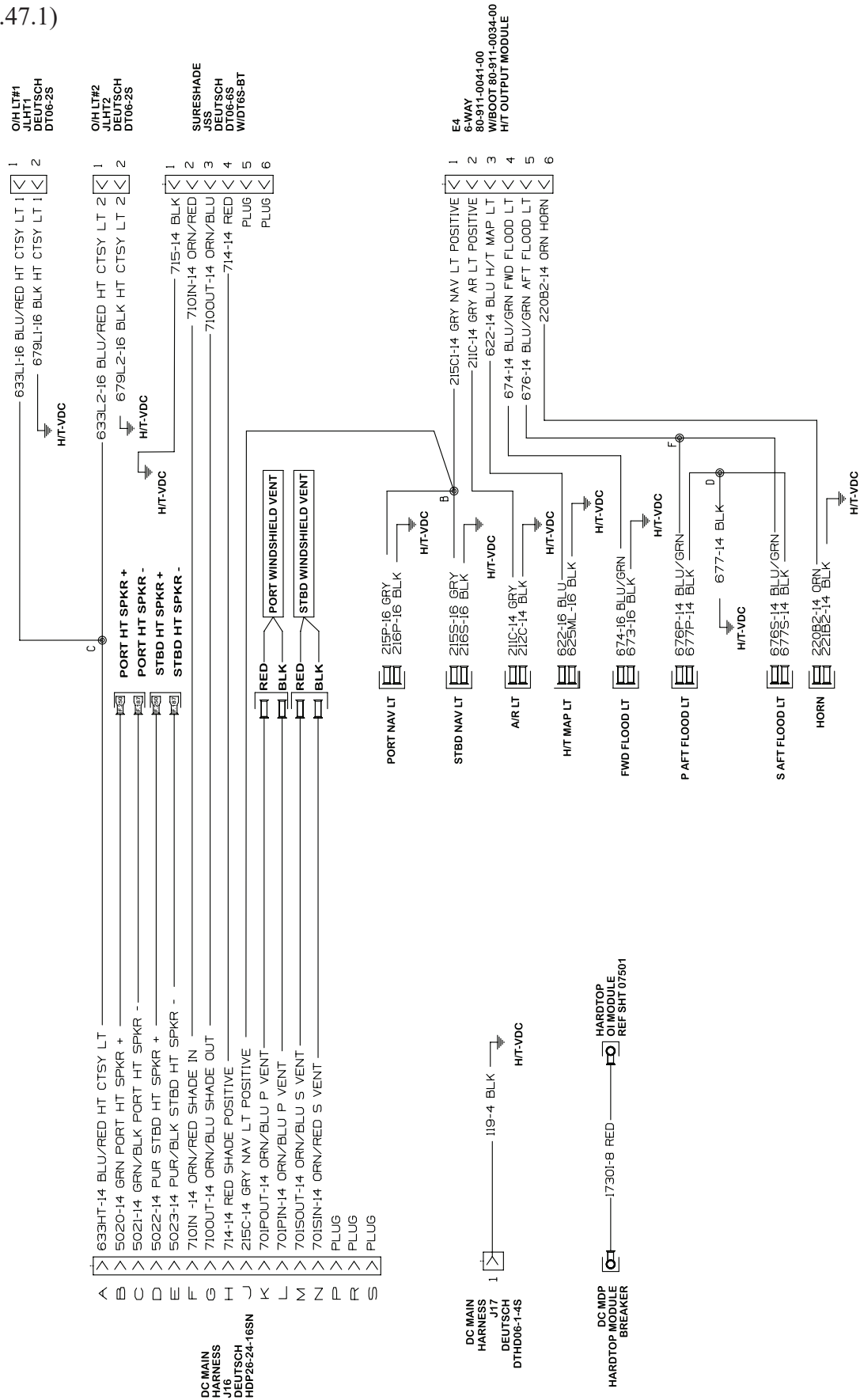

Cabin DC
(FIGURE 4.48.1)

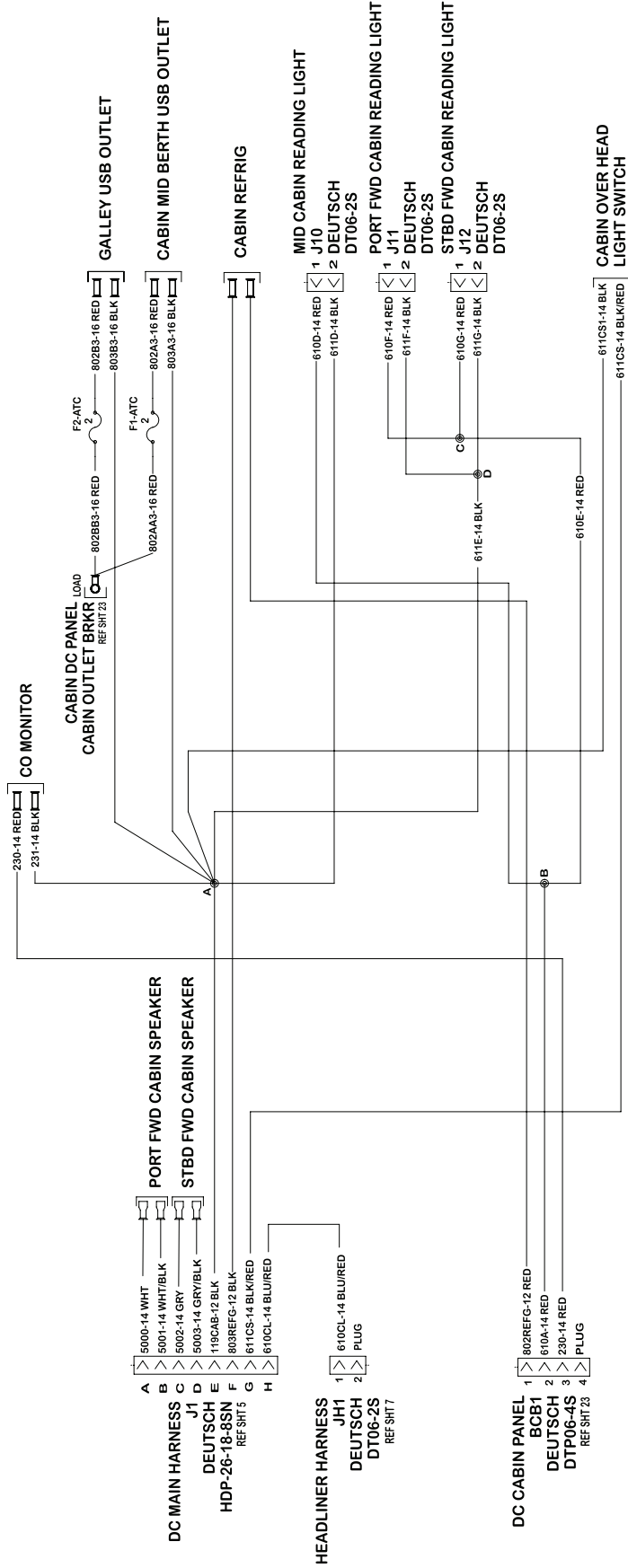

Stereo Amplifier DC
(FIGURE 4.49.1)

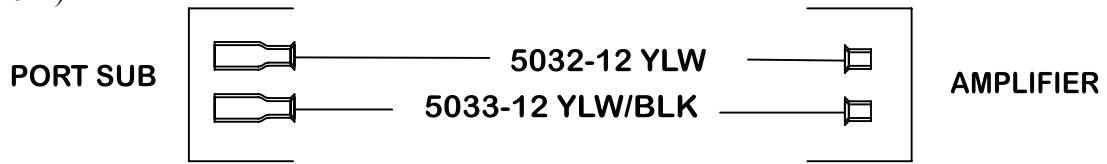

Windlass DC
(FIGURE 4.49.2)

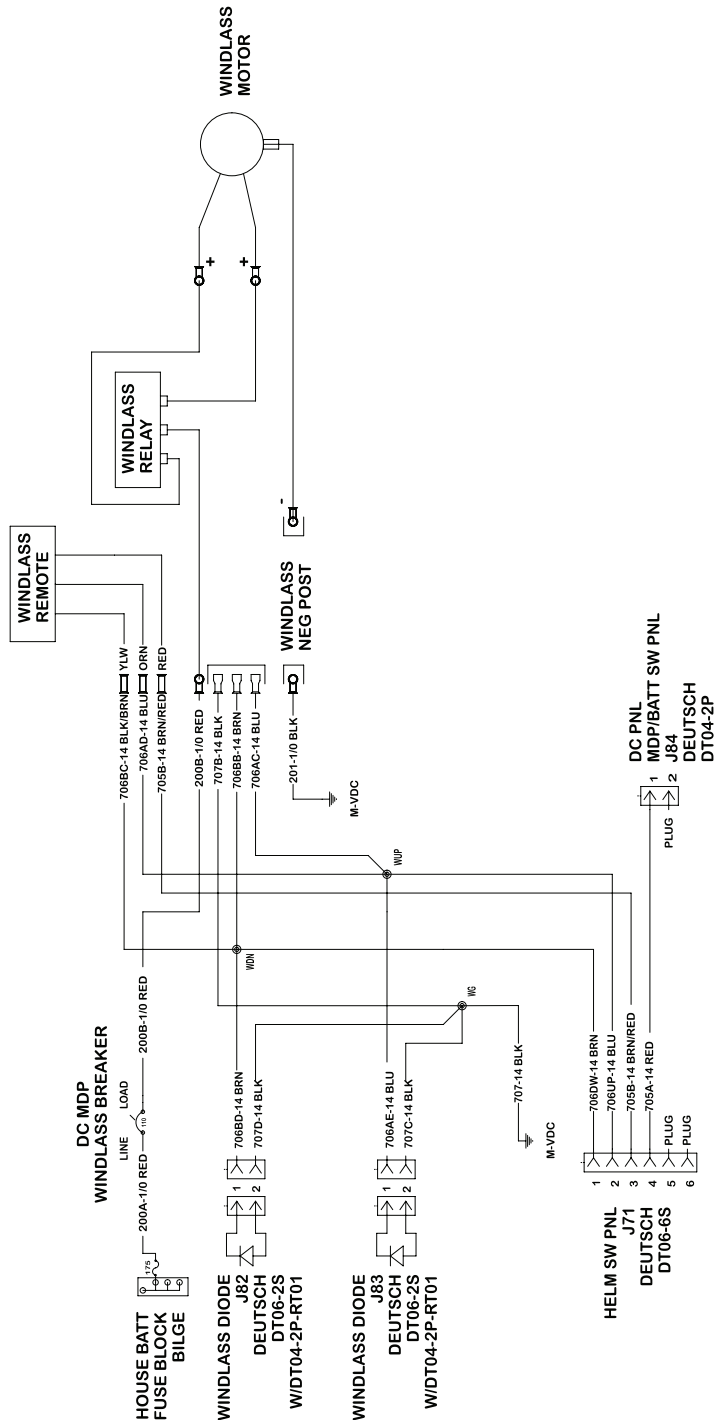

Windshield Washer/Wiper DC
(FIGURE 4.50.1)

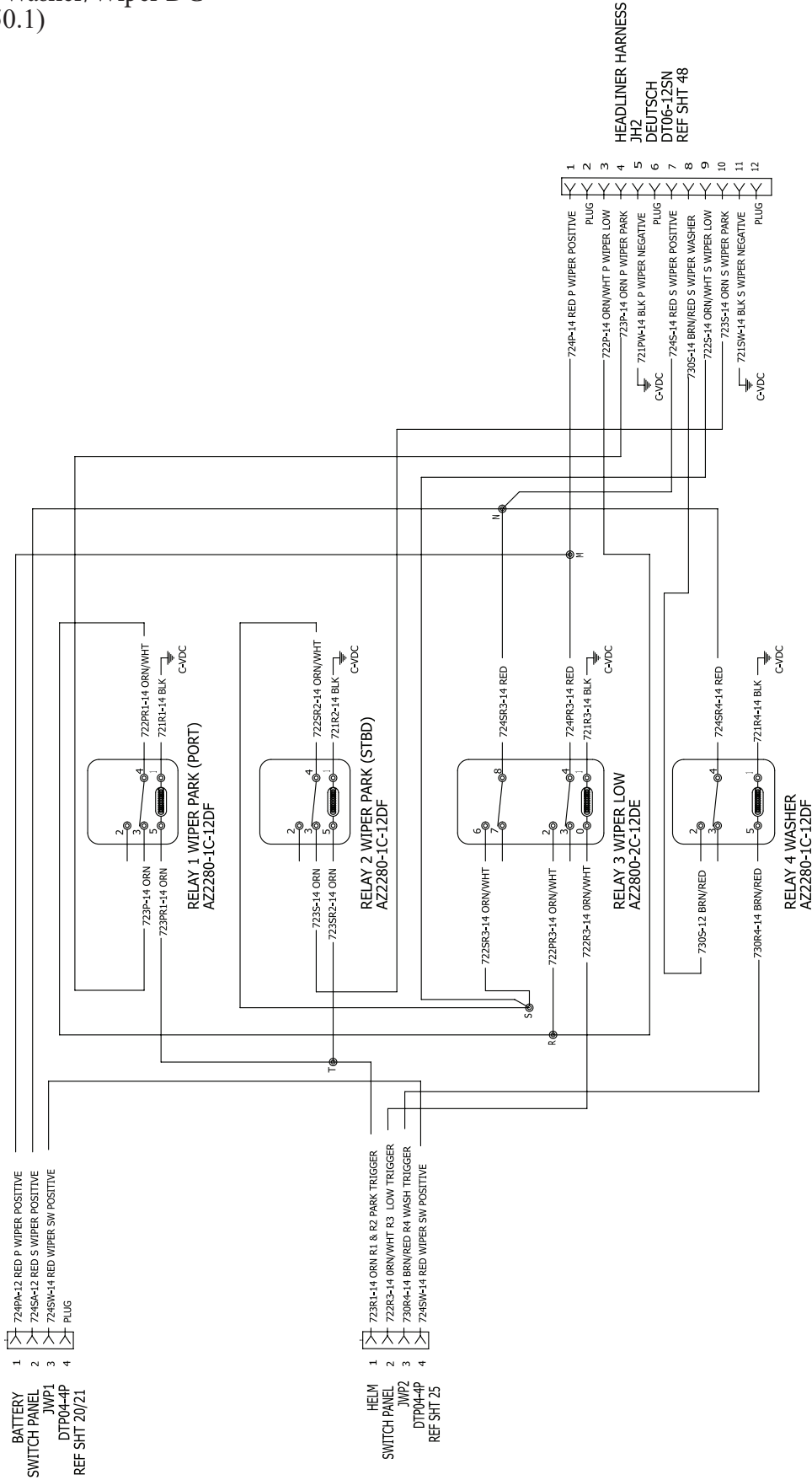

Autopilot DC
(FIGURE 4.51.1)

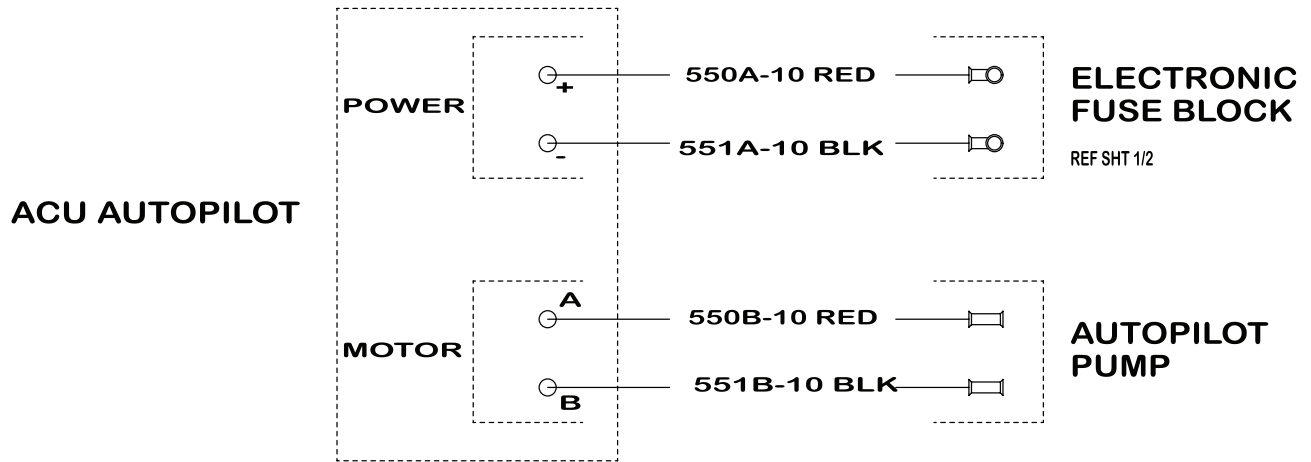

Joystick Moving Prop Alert DC
(FIGURE 4.51.2)

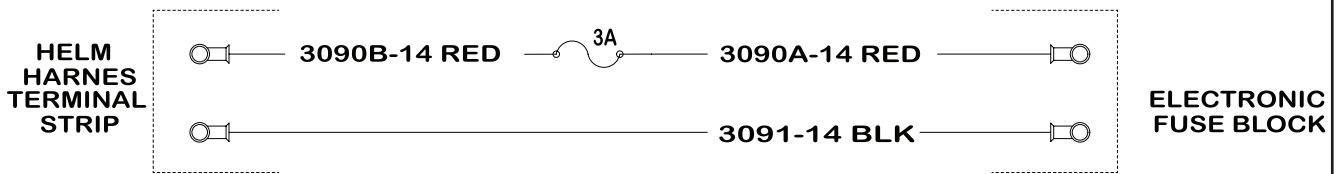

VHF Radio Power DC
(FIGURE 4.51.3)

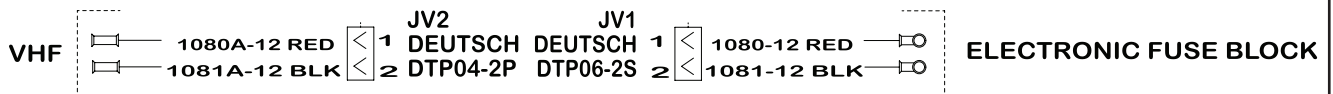

Heater DC
(FIGURE 4.51.4)

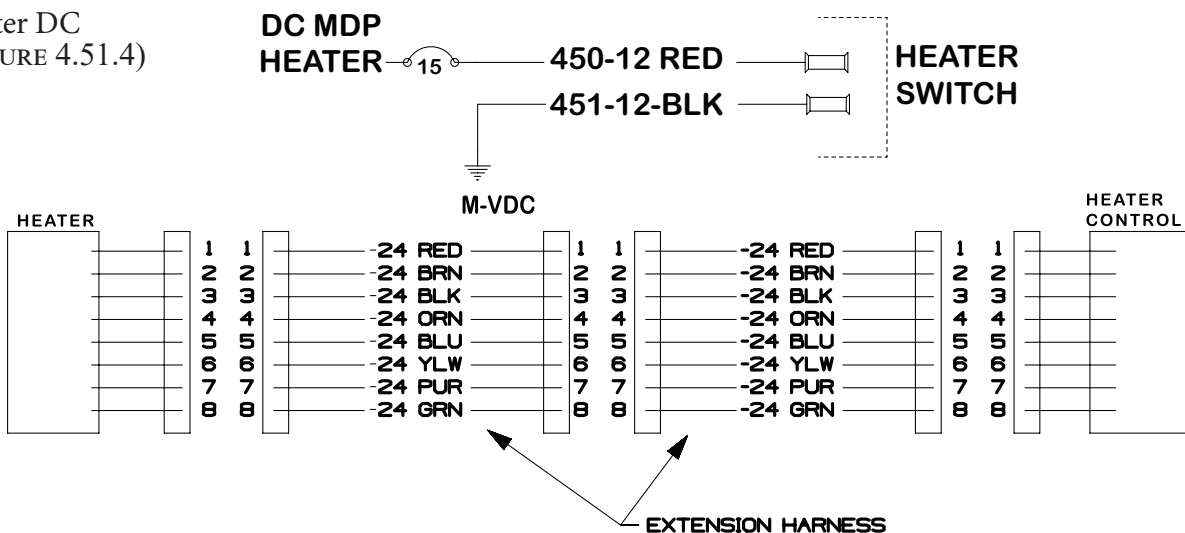

Power Steering DC
(FIGURE 4.52.1)

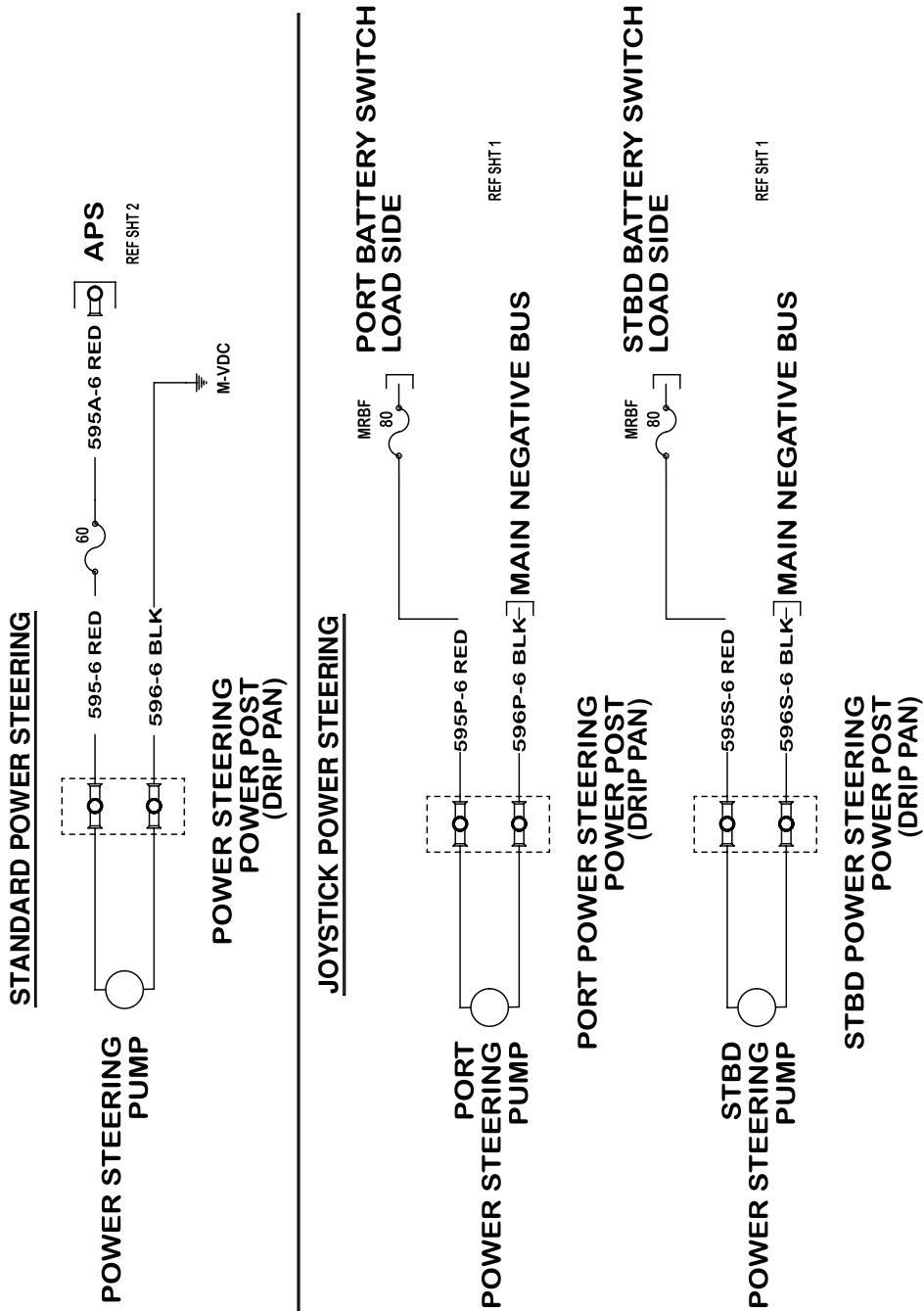

NAUTIC-ON Bilge Pump Two Position Adaptor DC
(FIGURE 4.53.1)

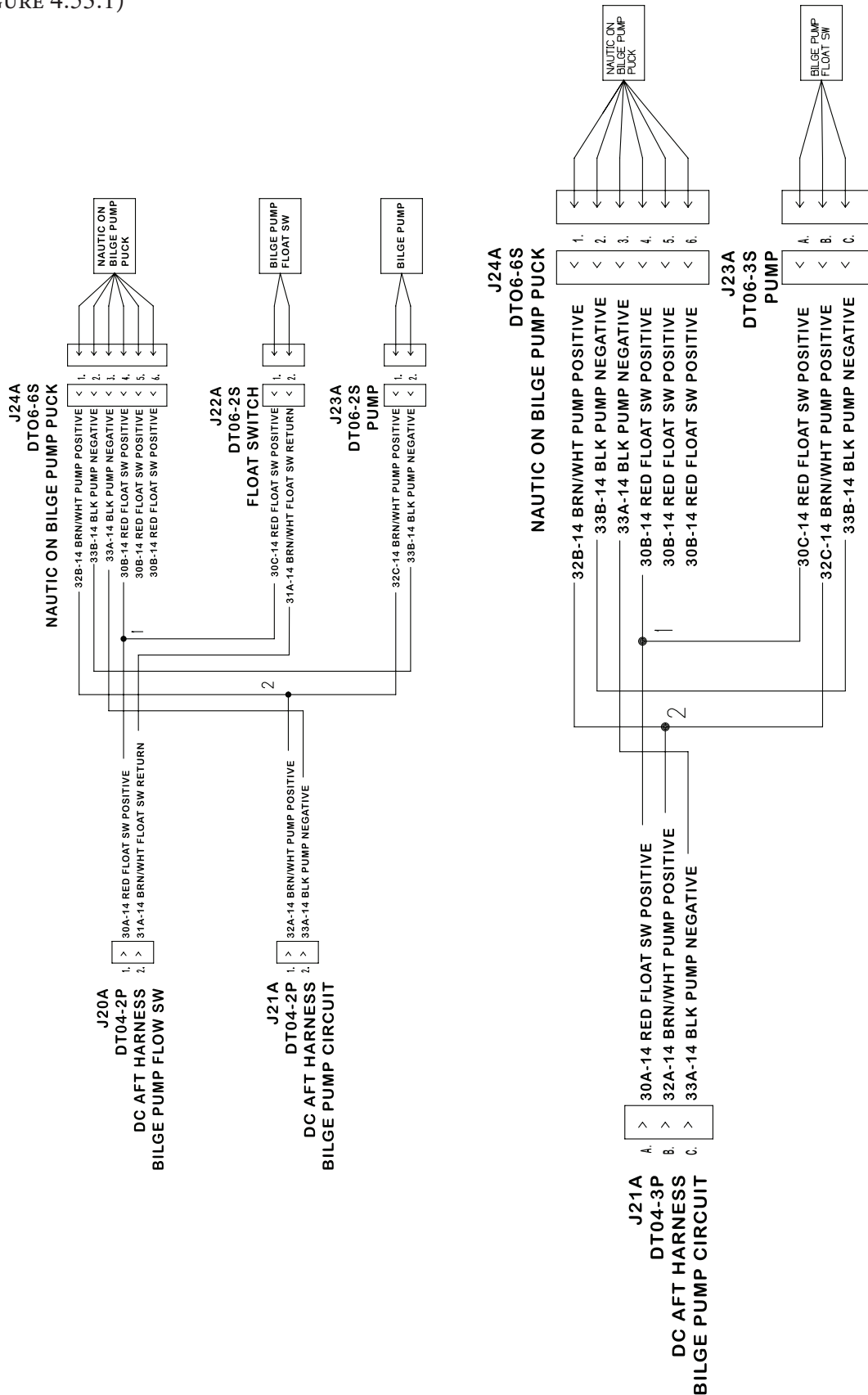

NAUTIC-ON Bilge Pump Three Position Adaptor DC
(FIGURE 4.54.1)

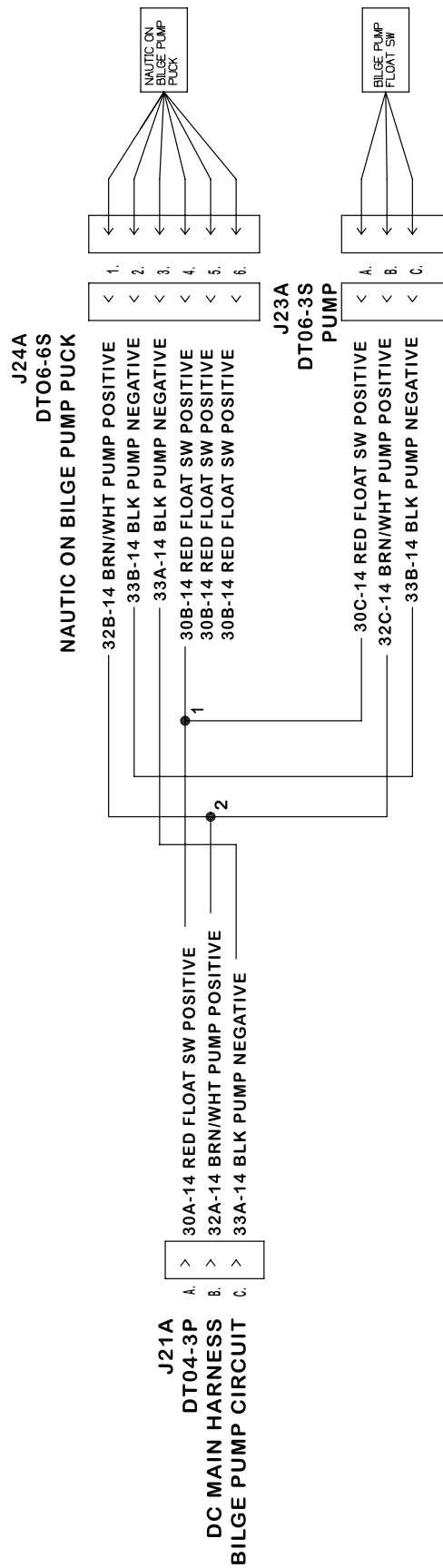

Battery Switch Panel with Gyroscopic Stabilizer DC (FIGURE 4.55.1)

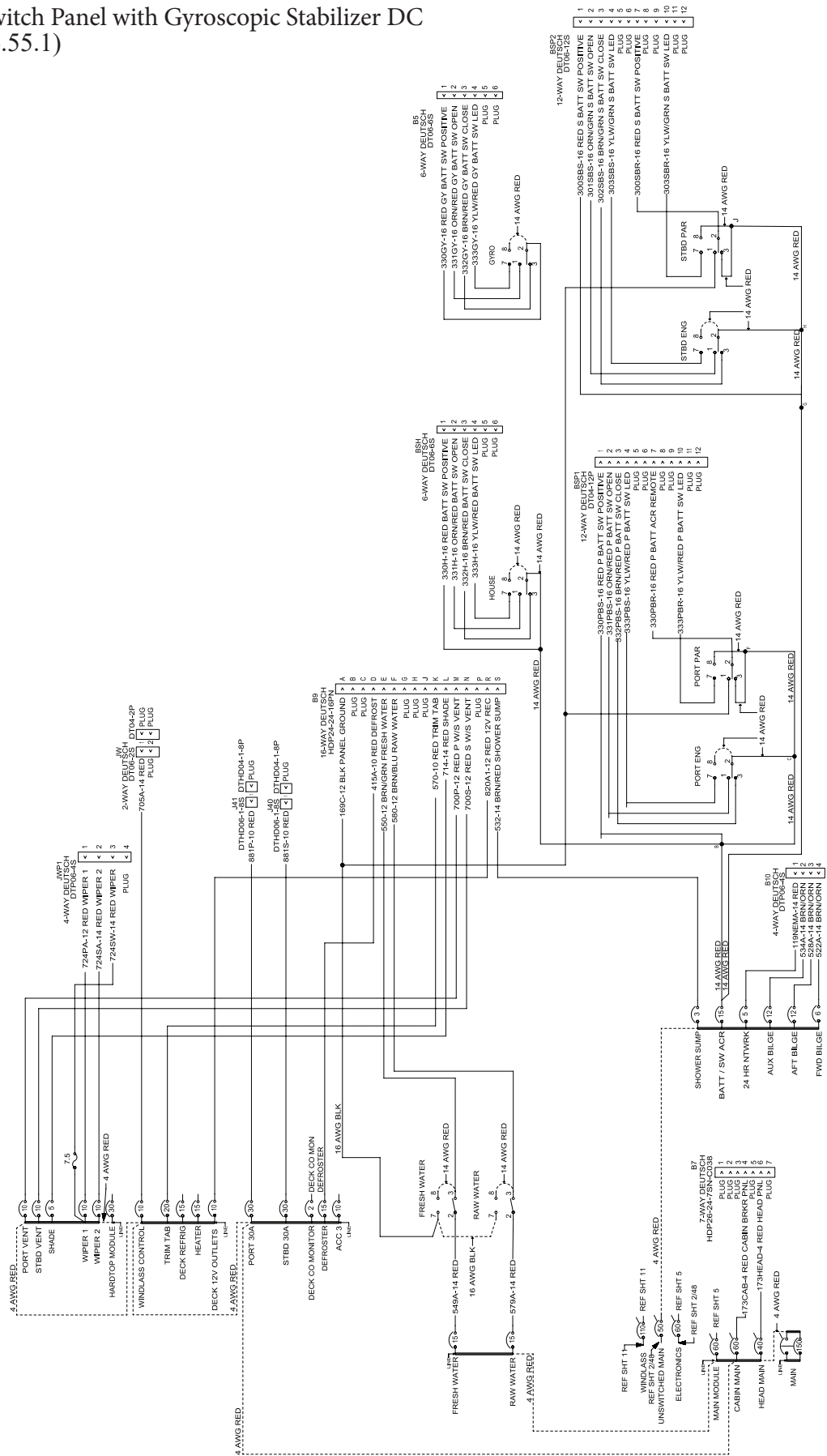

Battery Switch Panel (no gyroscopic stabilizer DC)
(FIGURE 4.56.1)

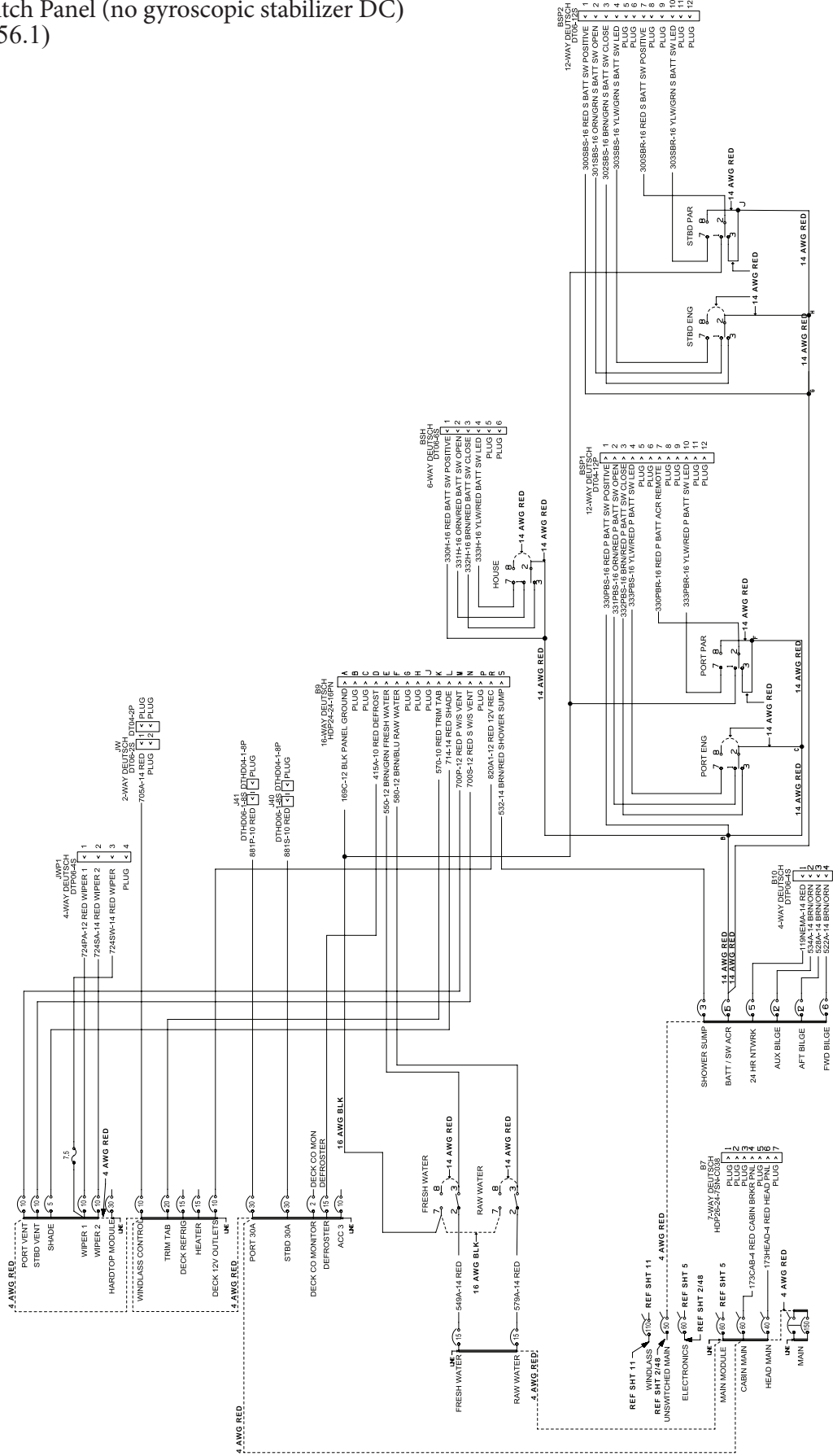

Head Switch Panel DC
(FIGURE 4.57.1)

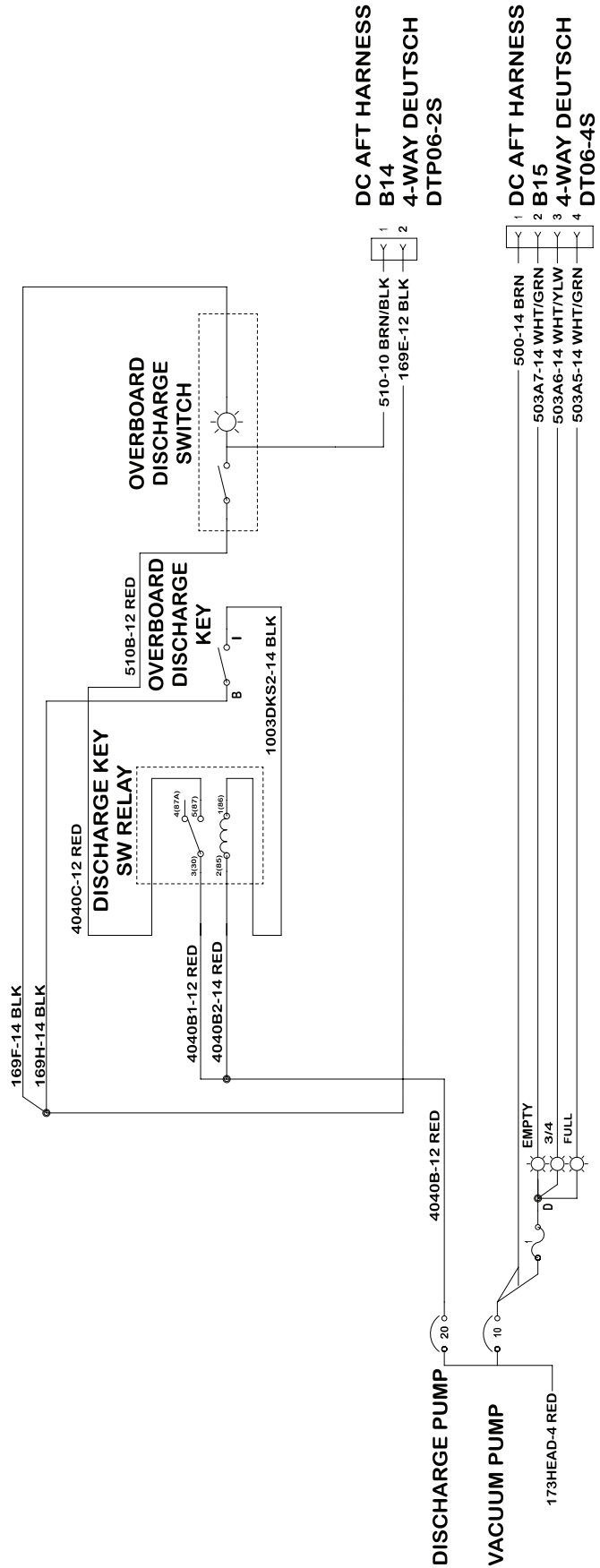

Cabin Breaker Panel DC
(FIGURE 4.58.1)

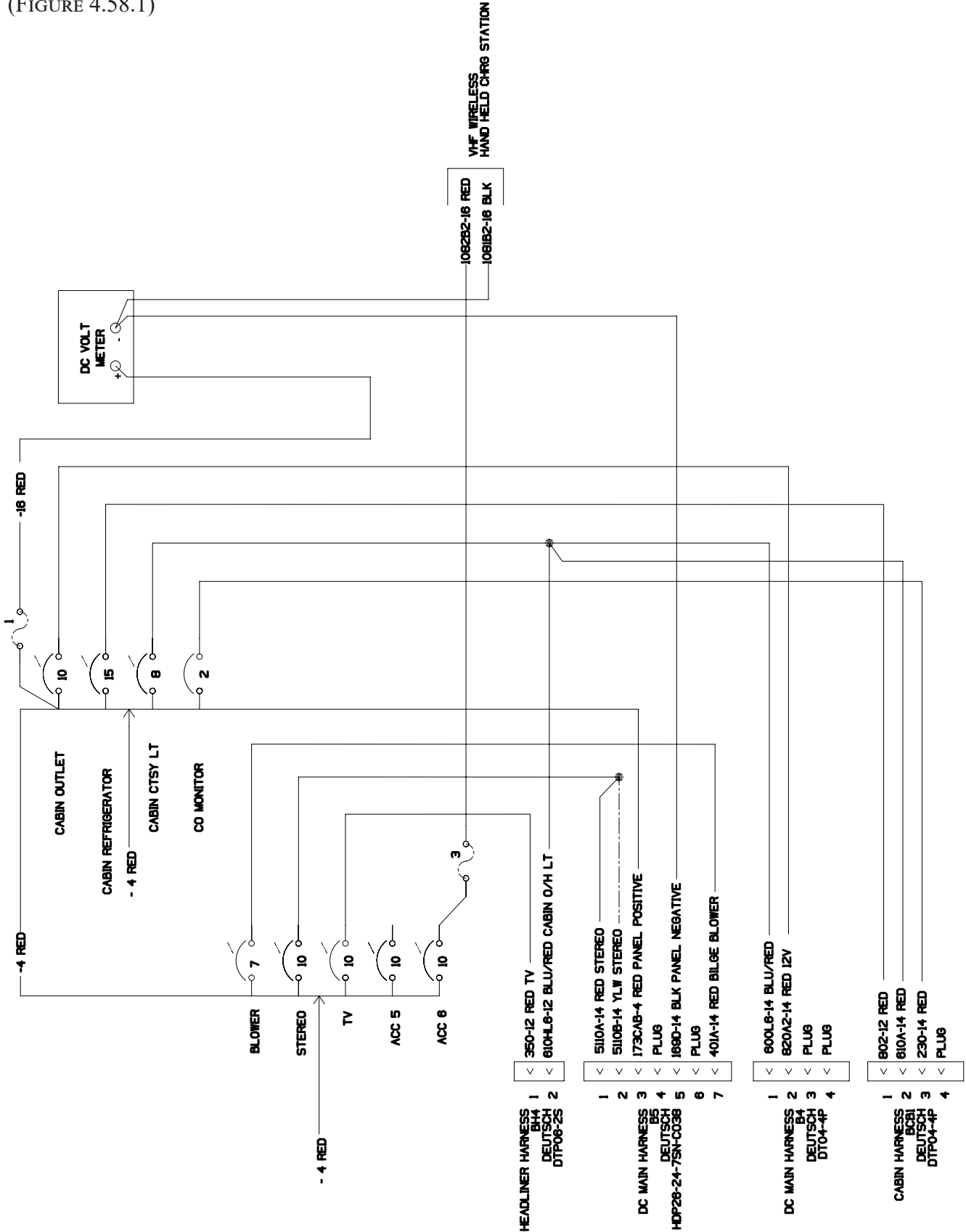

Pilothouse CO Monitor DC
(FIGURE 4.59.1)

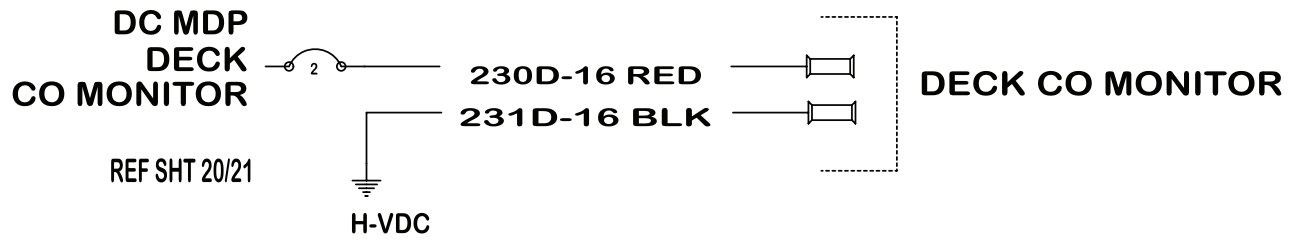

Generator Switch Panel DC
(FIGURE 4.59.2)

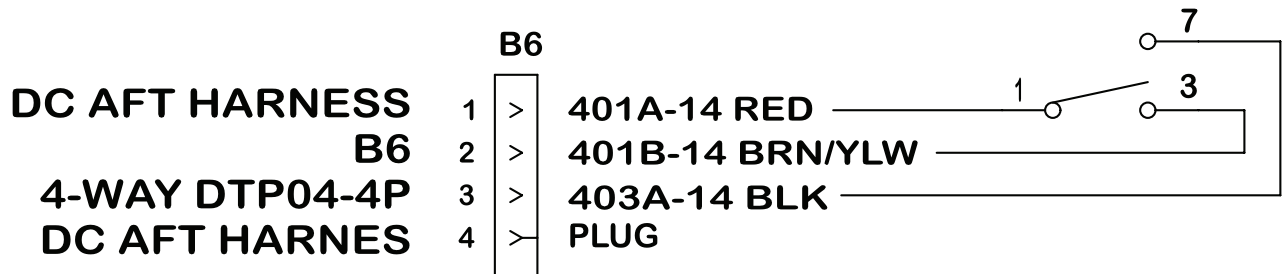

Helm Switch Panel DC (FIGURE 4.60.1)

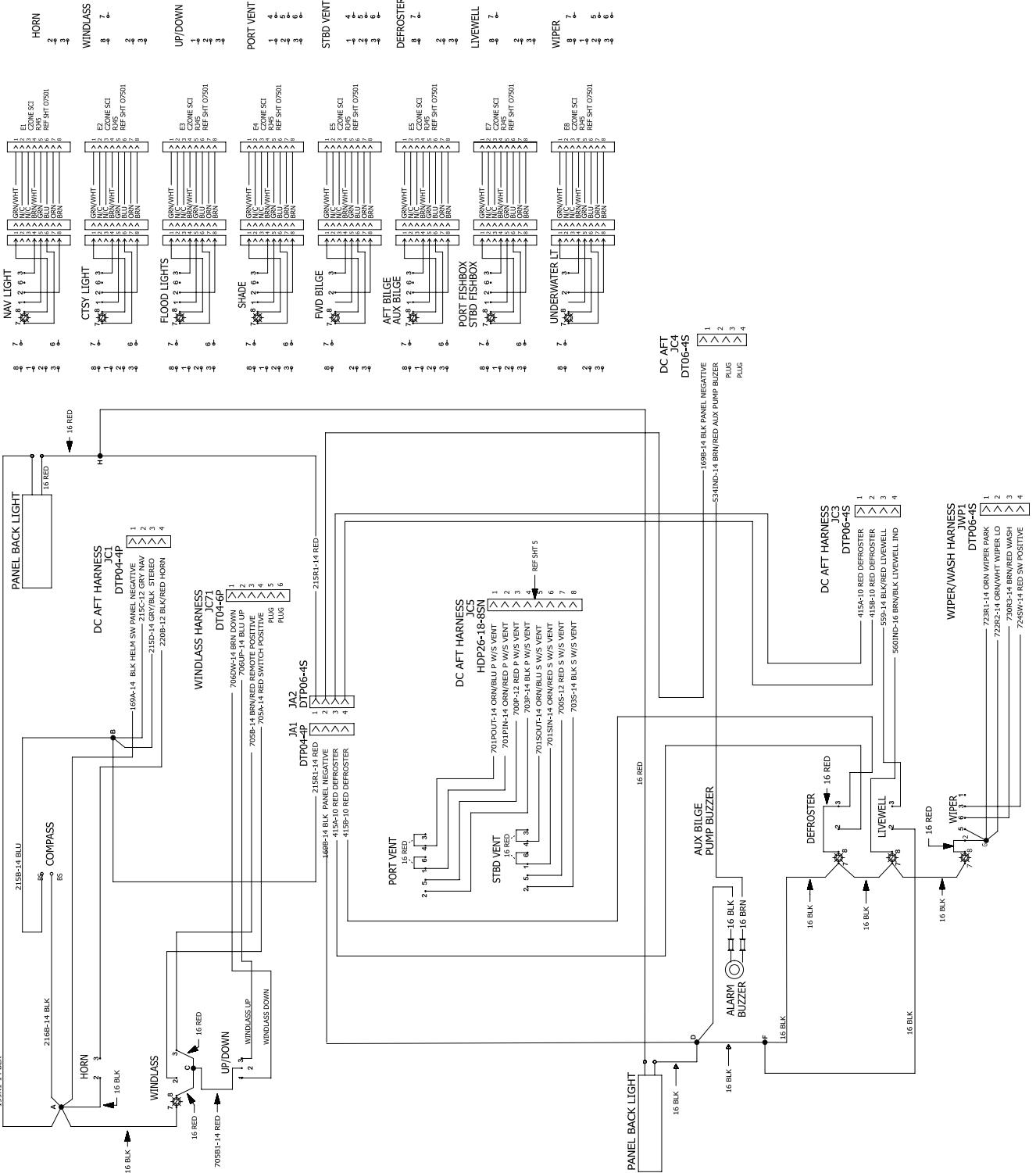

Shore Power 1 and 2 with Generator 120V/60Hz AC
(FIGURE 4.61.1)

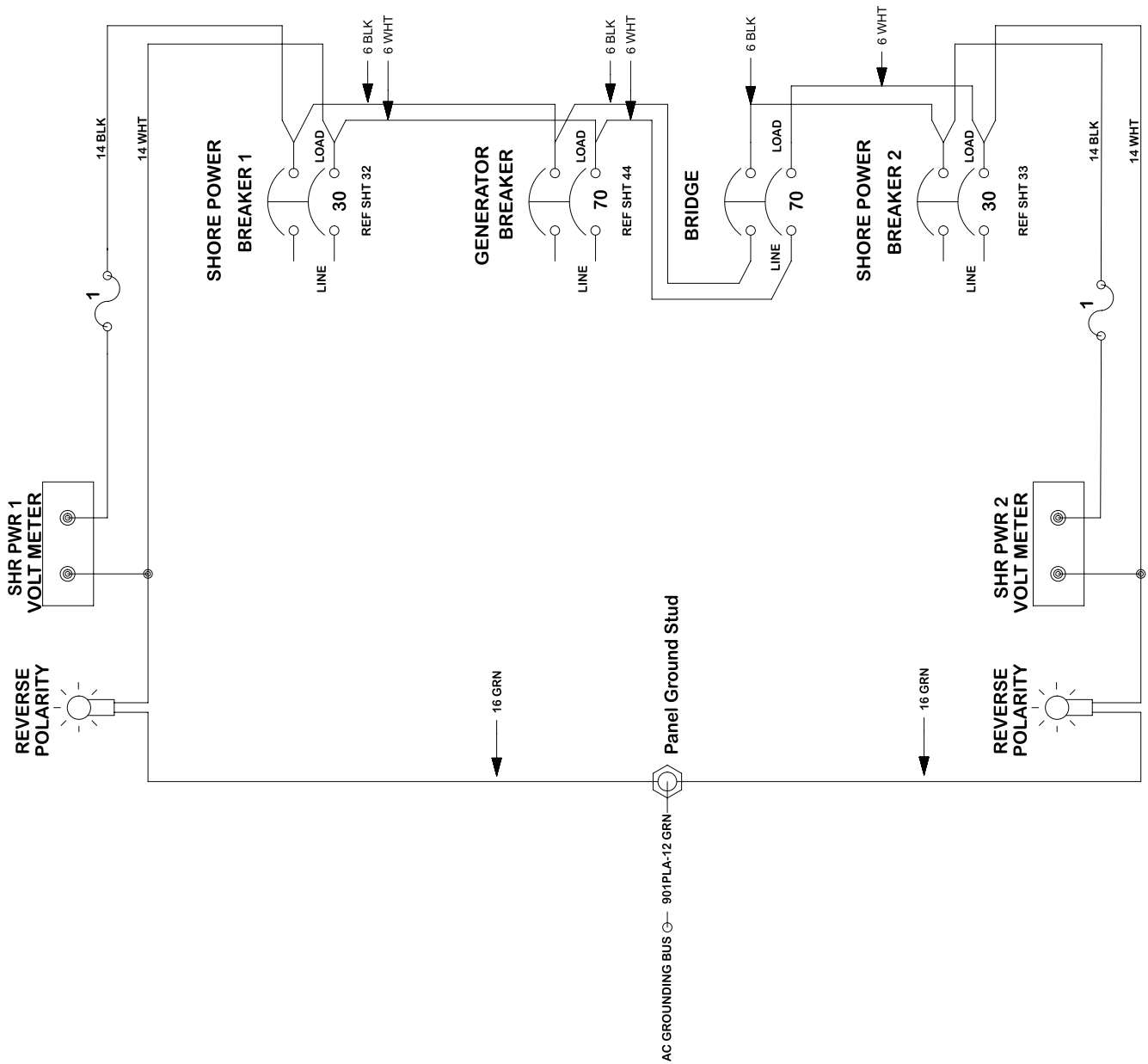

Shore Power 1 and 2 no Generator 120V/60Hz AC
(FIGURE 4.62.1)

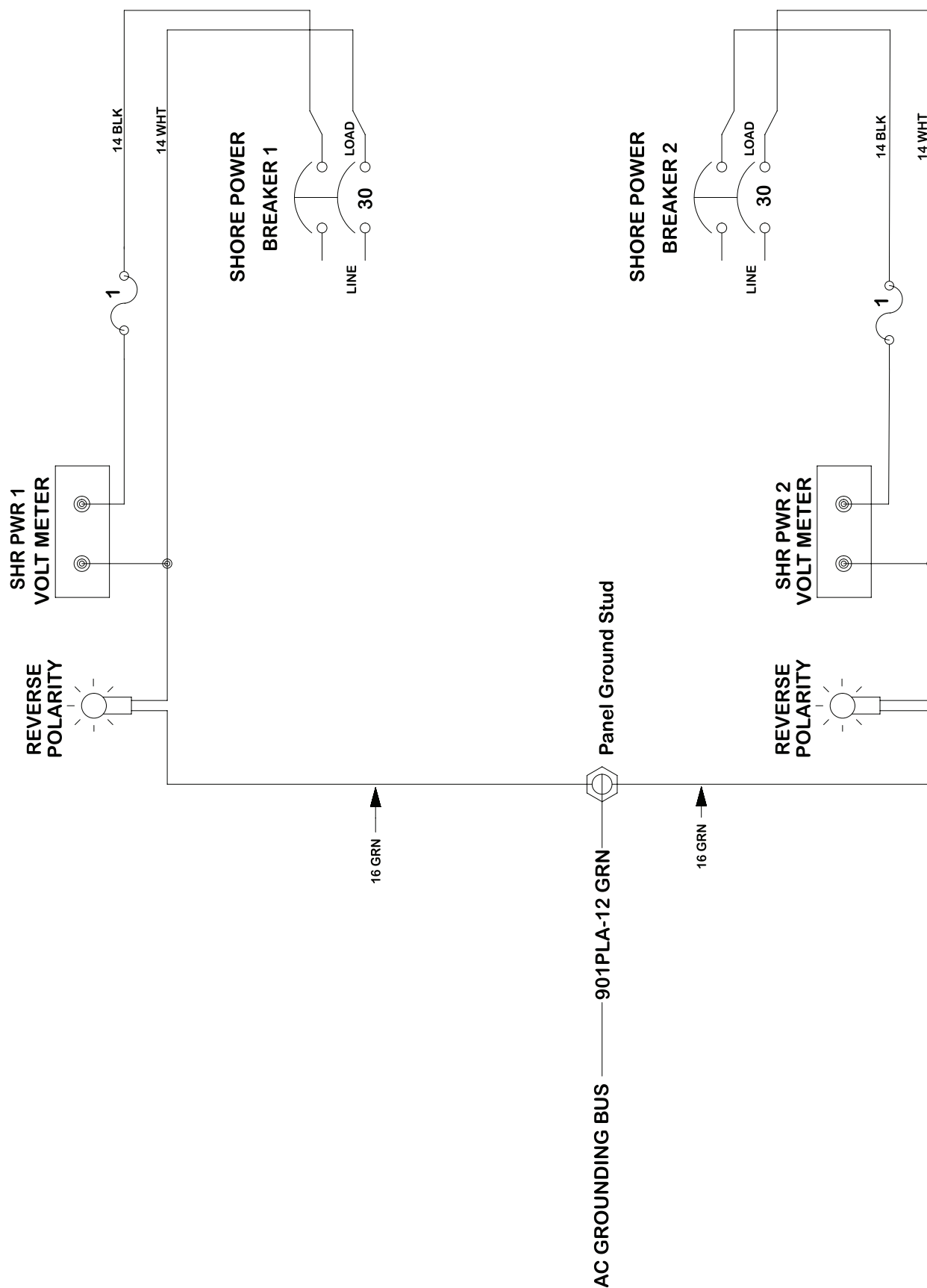

Shore Power with Generator 120V/60Hz AC
(FIGURE 4.63.1)

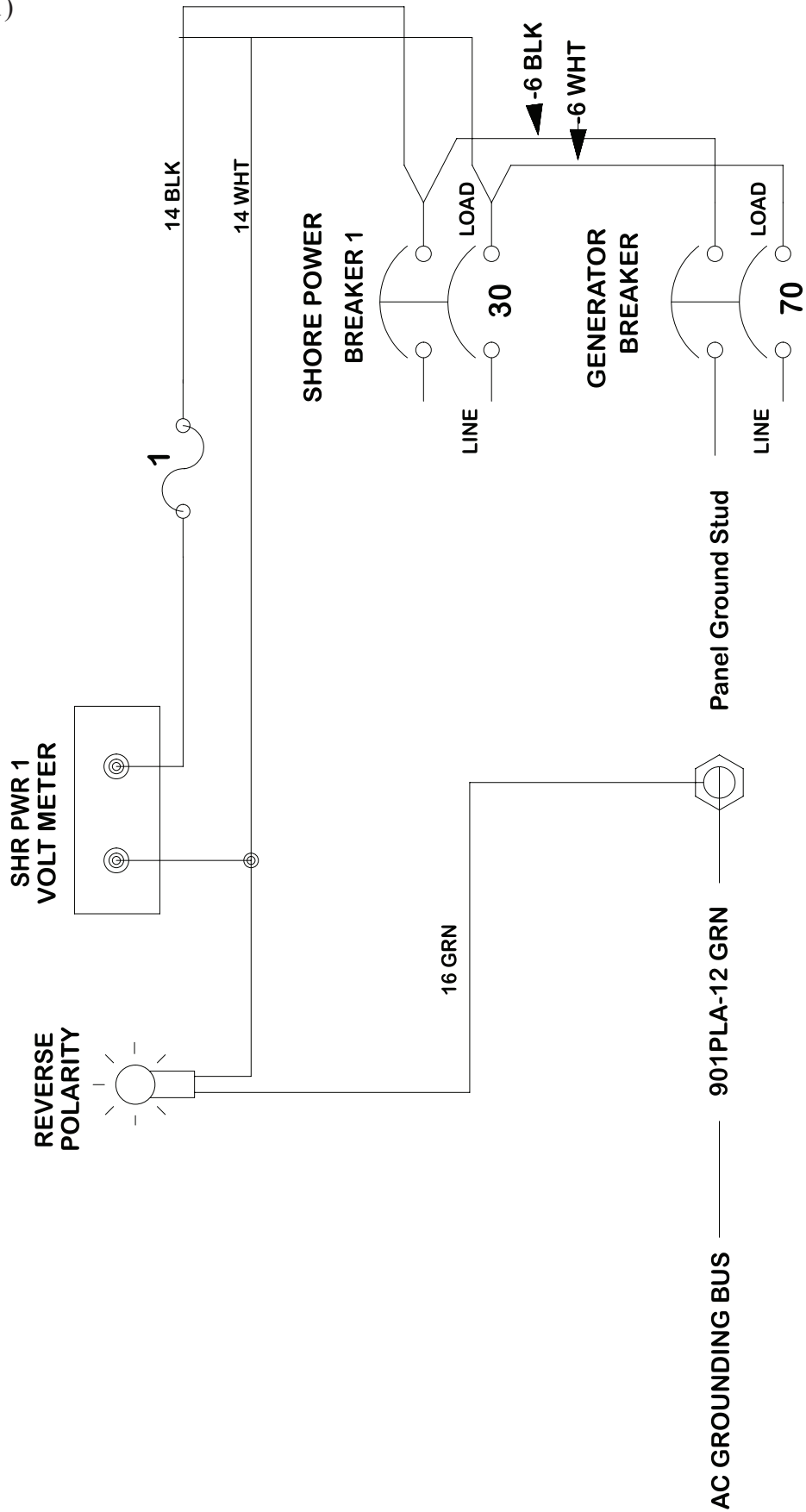

Shore Power no Generator 120V/60Hz AC
(FIGURE 4.64.1)

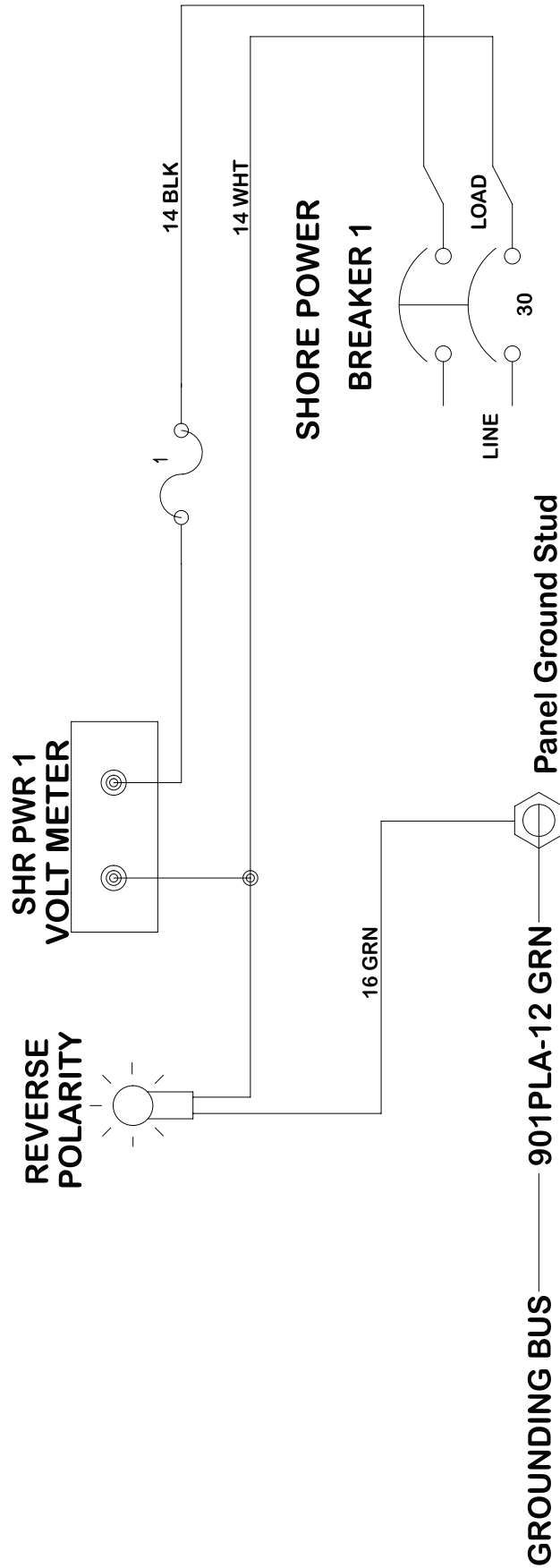

Shore Power 1 Breaker Panel 120V/60Hz AC
(FIGURE 4.65.1)

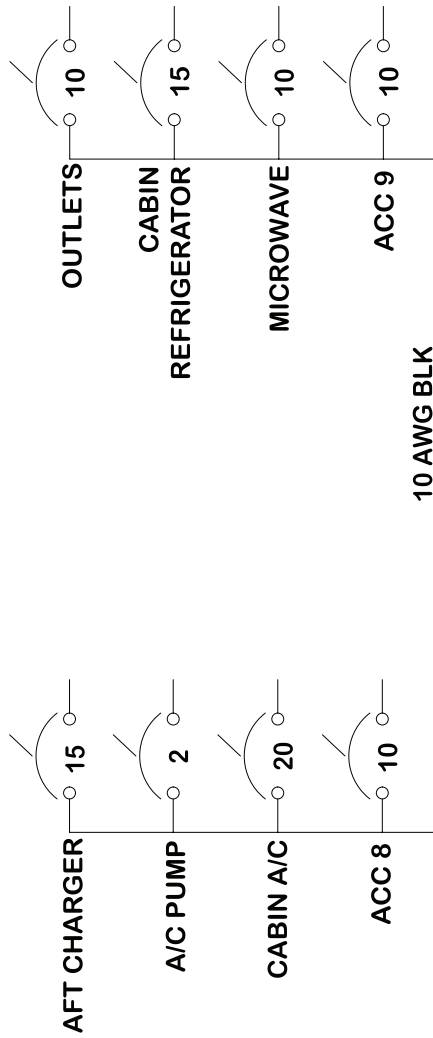

Shore Power 2 Breaker Panel 120V/60Hz AC
(FIGURE 4.66.1)

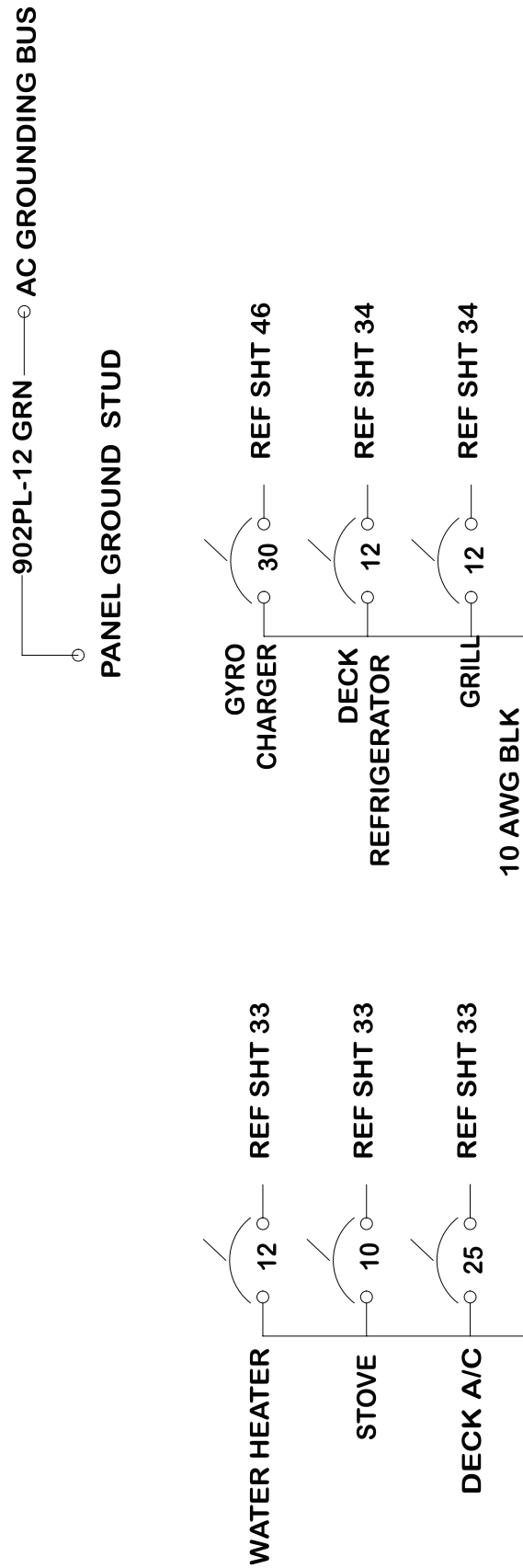

Shore Power 1 AC System 120V/60Hz
(FIGURE 4.67.1)

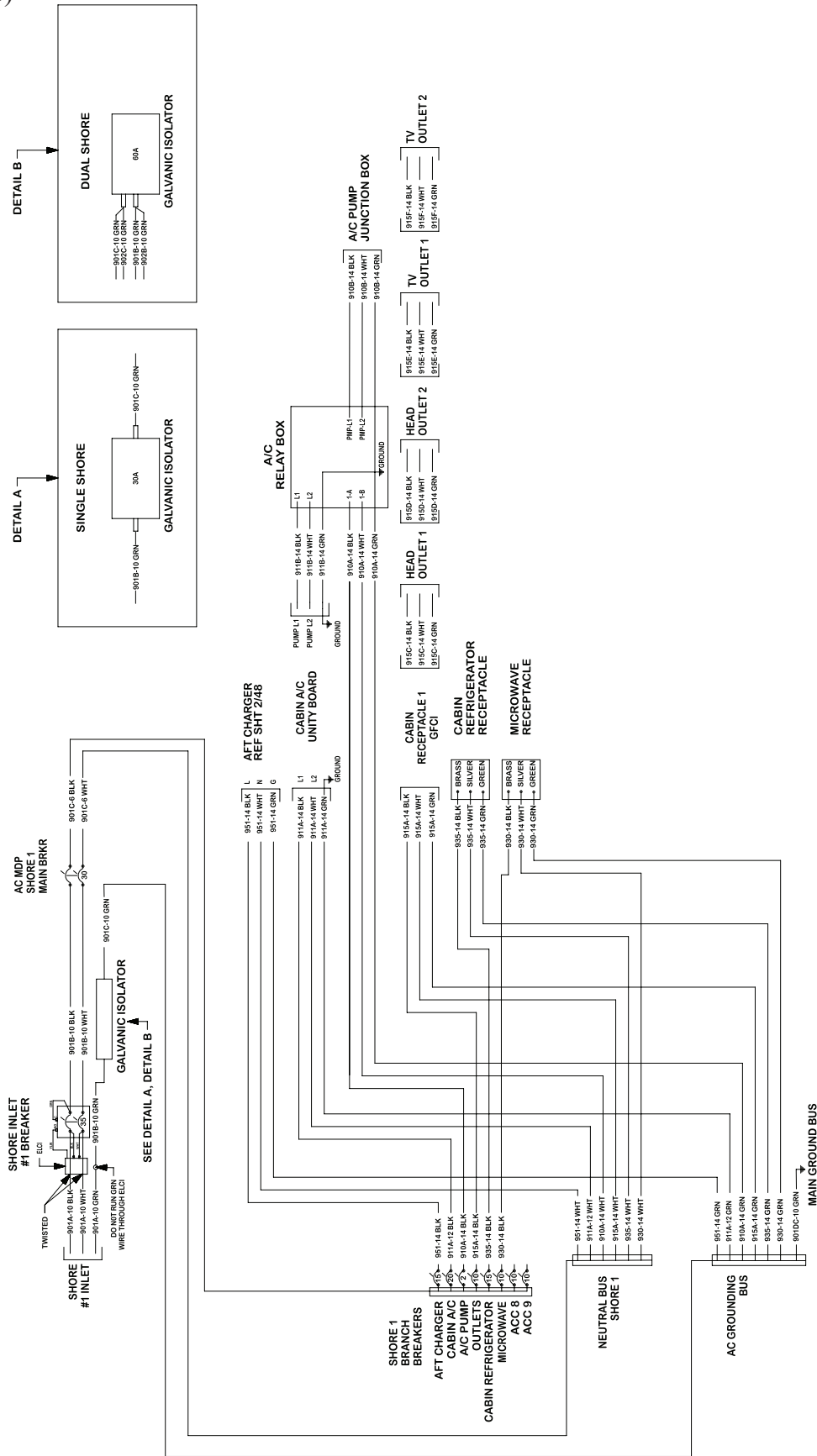

Shore Power 2 AC System 120V/60Hz
(FIGURE 4.68.1)

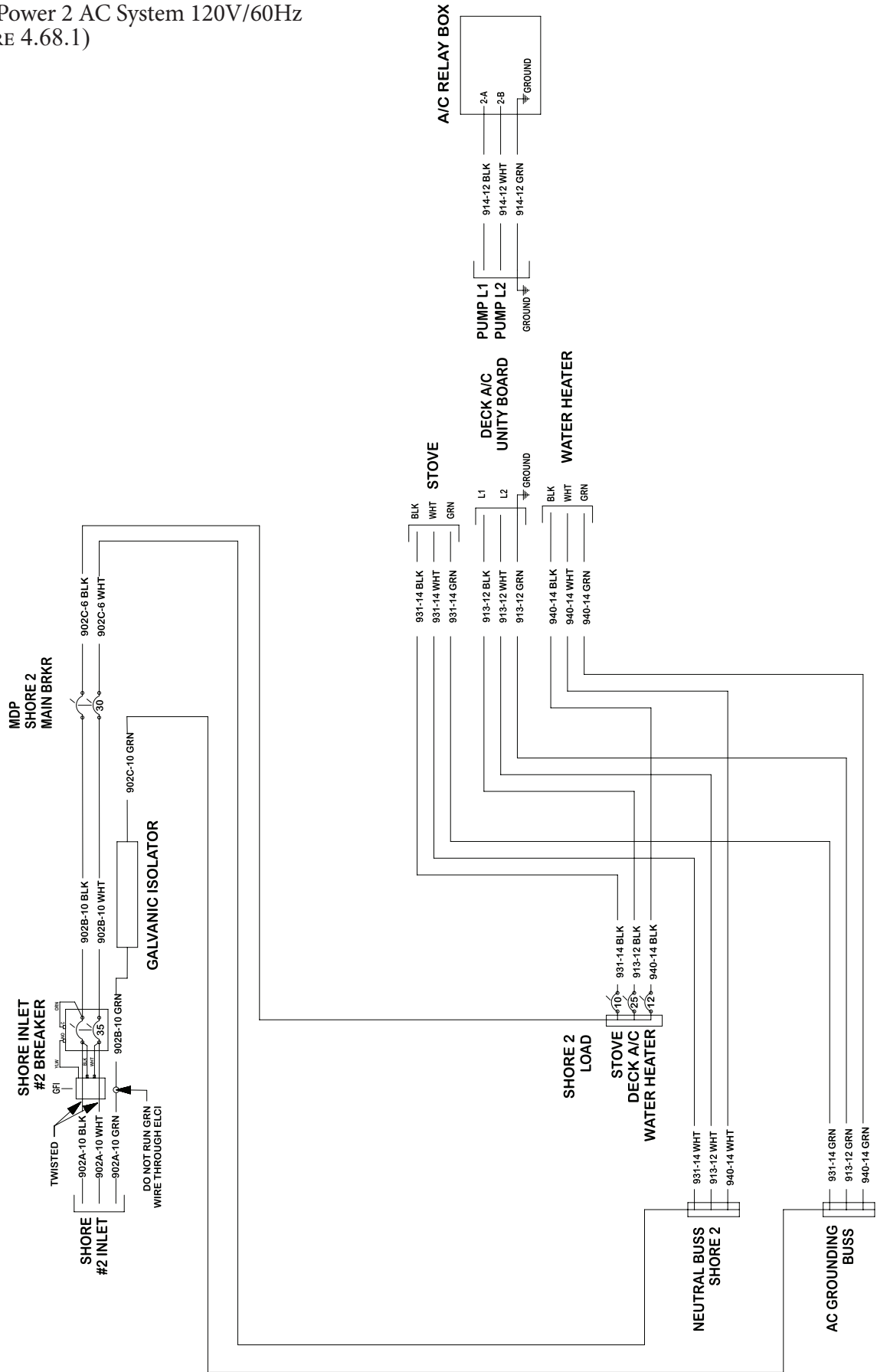

Grill 120VAC and Fridge 12VDC
(FIGURE 4.69.1)

120VAC

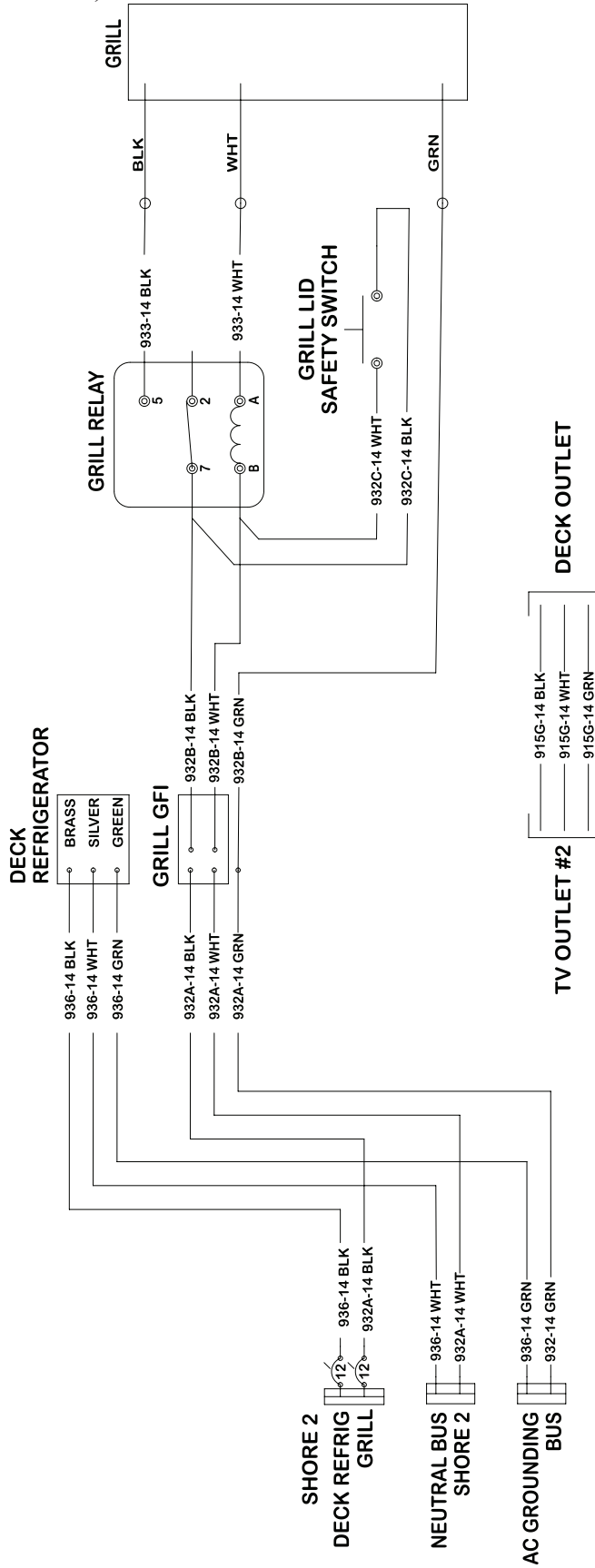

12VDC

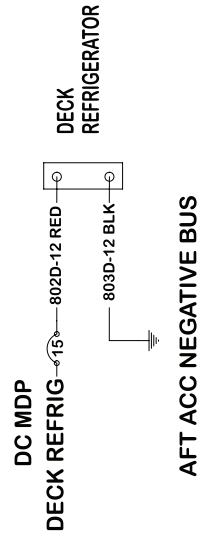

Shore Power 1 and 2 with Generator 230V/50Hz AC
(FIGURE 4.70.1)

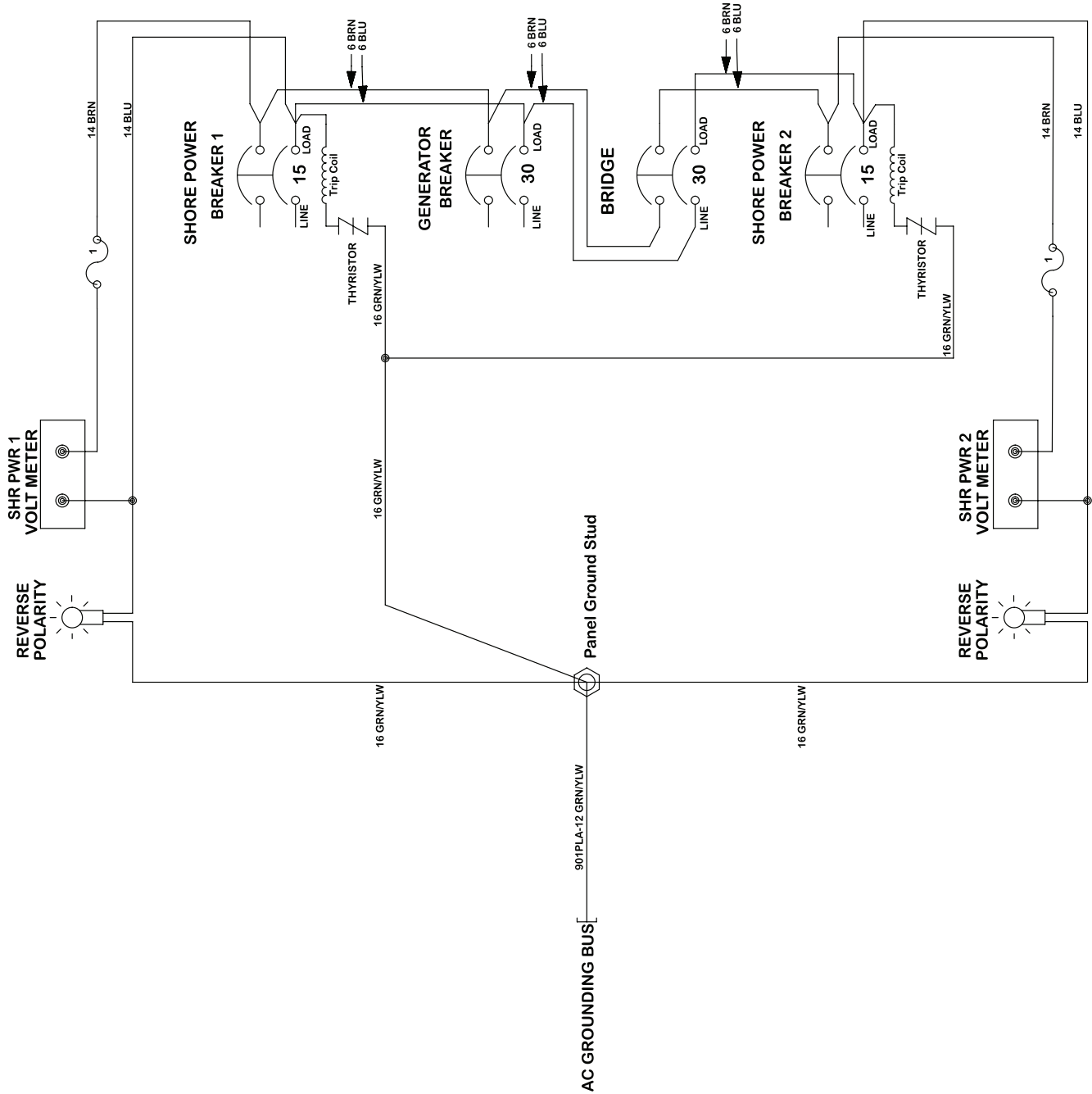

Shore Power 1 and 2 no Generator 230V/50Hz AC
(FIGURE 4.71.1)

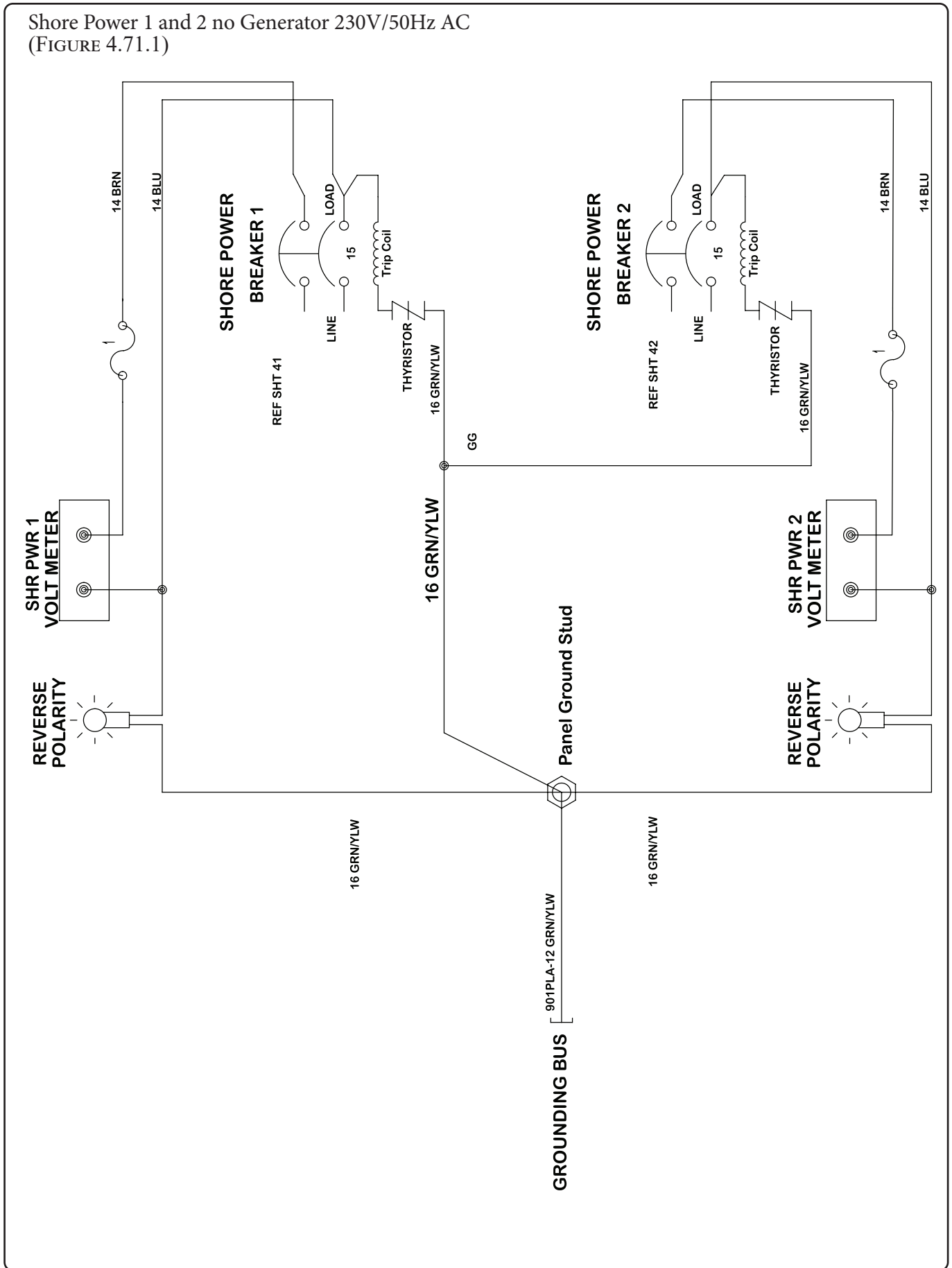

Shore Power with Generator 230V/50Hz AC
(FIGURE 4.72.1)

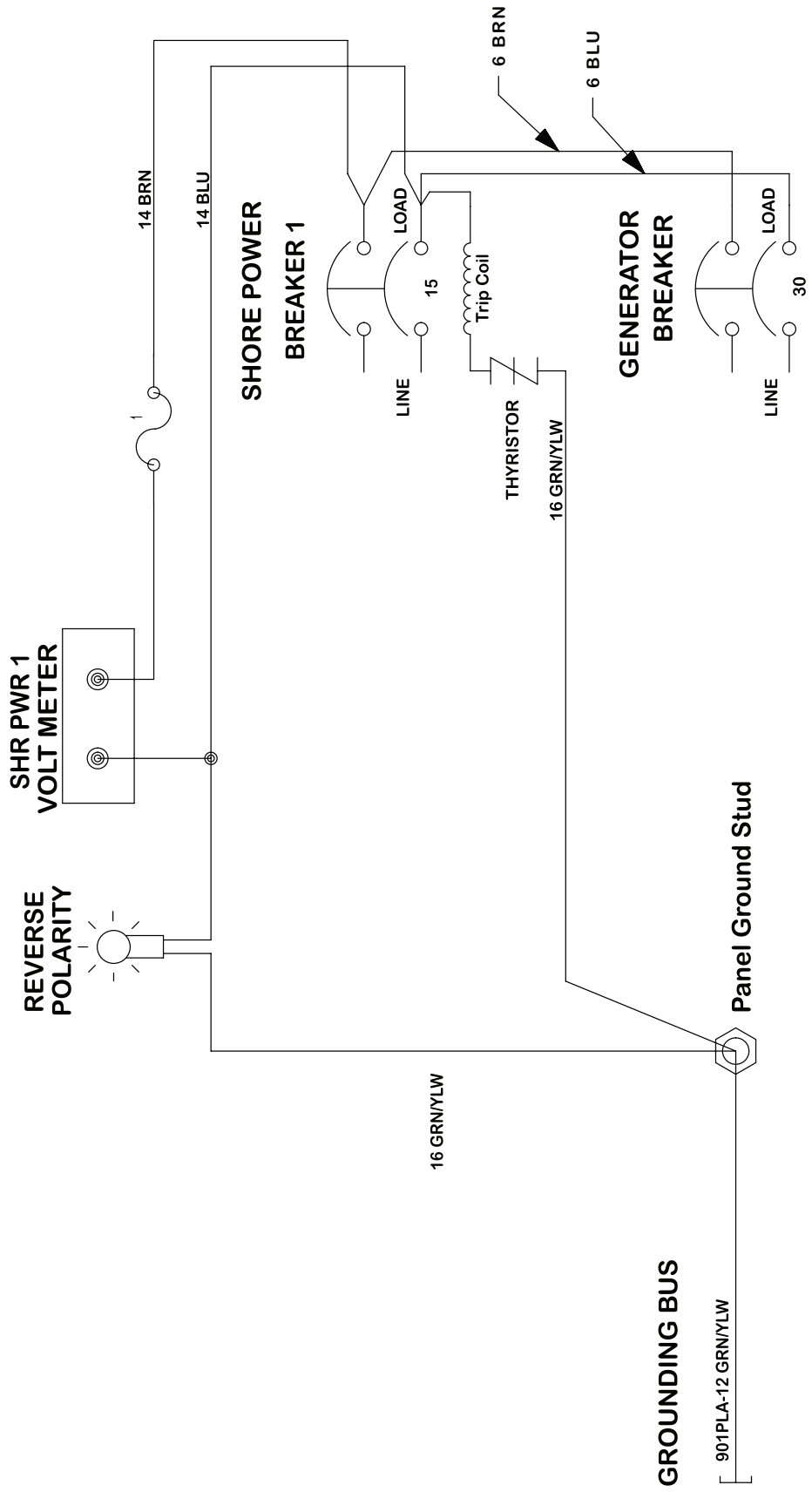

Shore Power no Generator 230V/50Hz AC
(FIGURE 4.73.1)

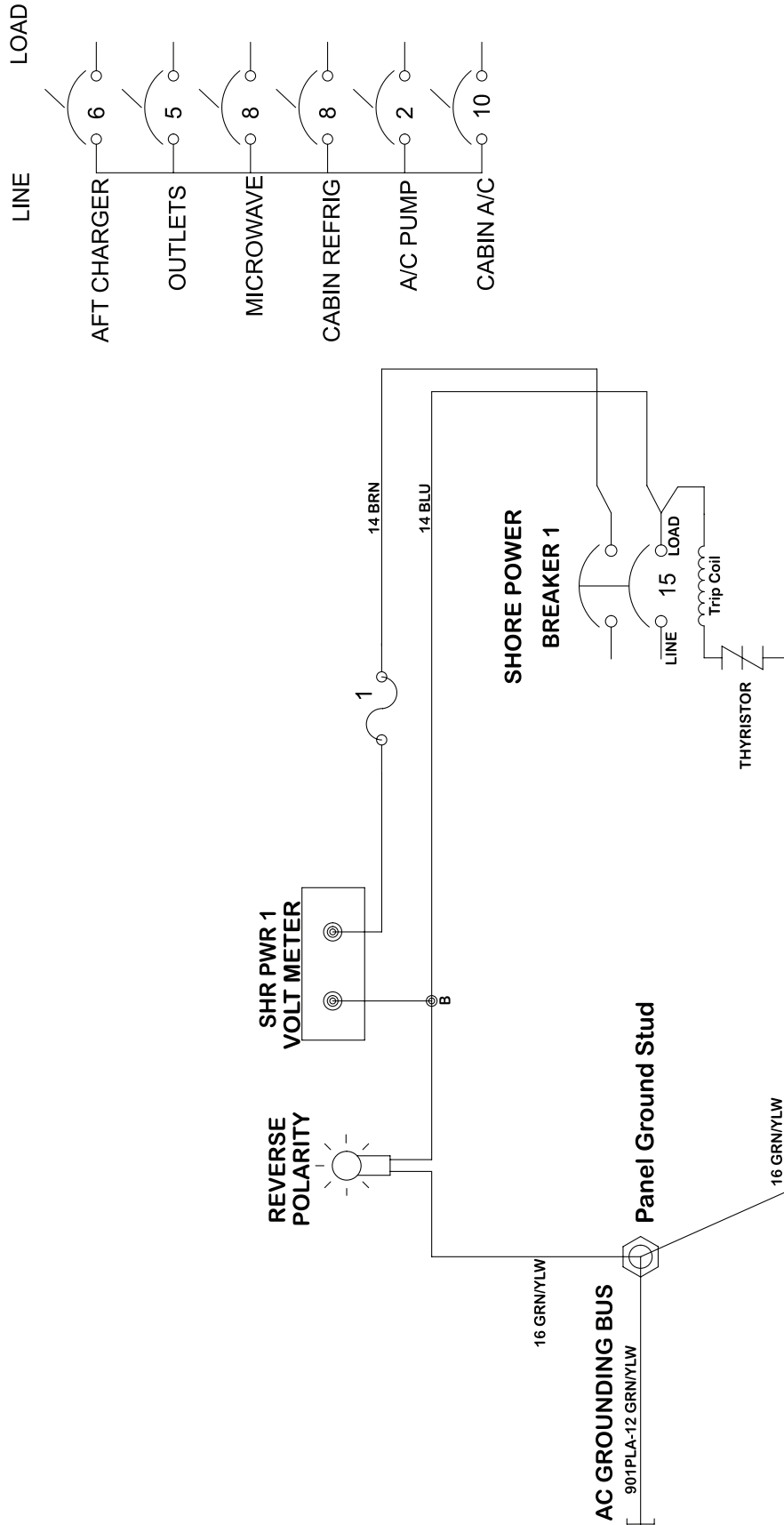

Shore Power 1 Breaker Panel 230V/50Hz AC
(FIGURE 4.74.1)

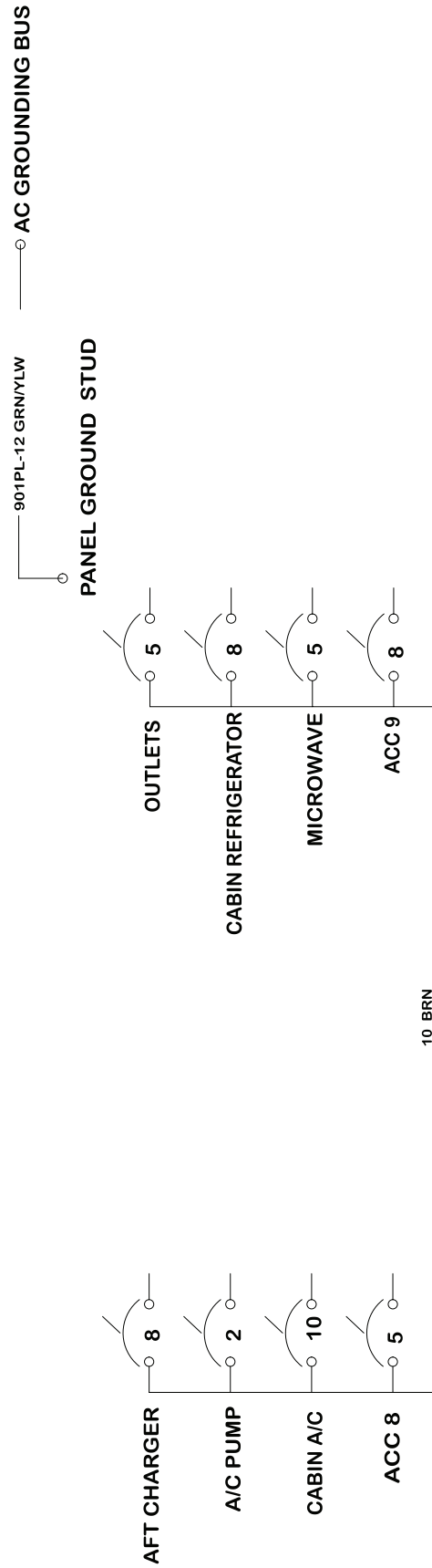

Chapter 4 • Electrical

Shore Power 2 Breaker Panel 230V/50Hz AC
(FIGURE 4.75.1)

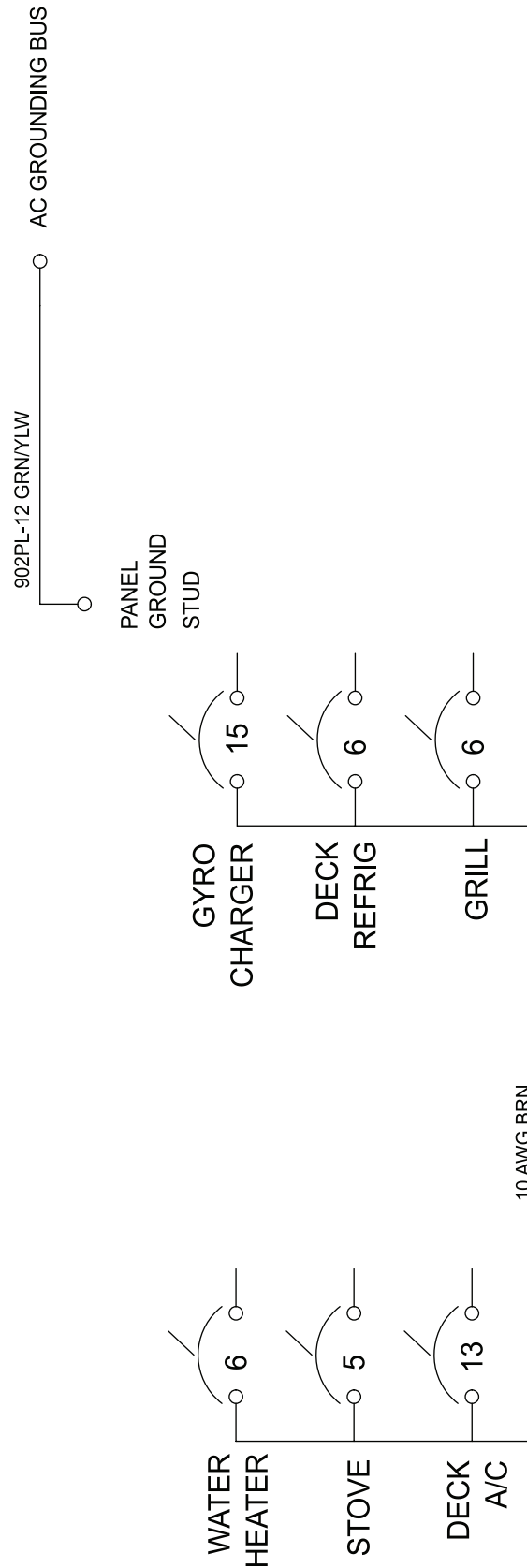

Shore Power 1 AC System 230V/50Hz
(FIGURE 4.76.1)

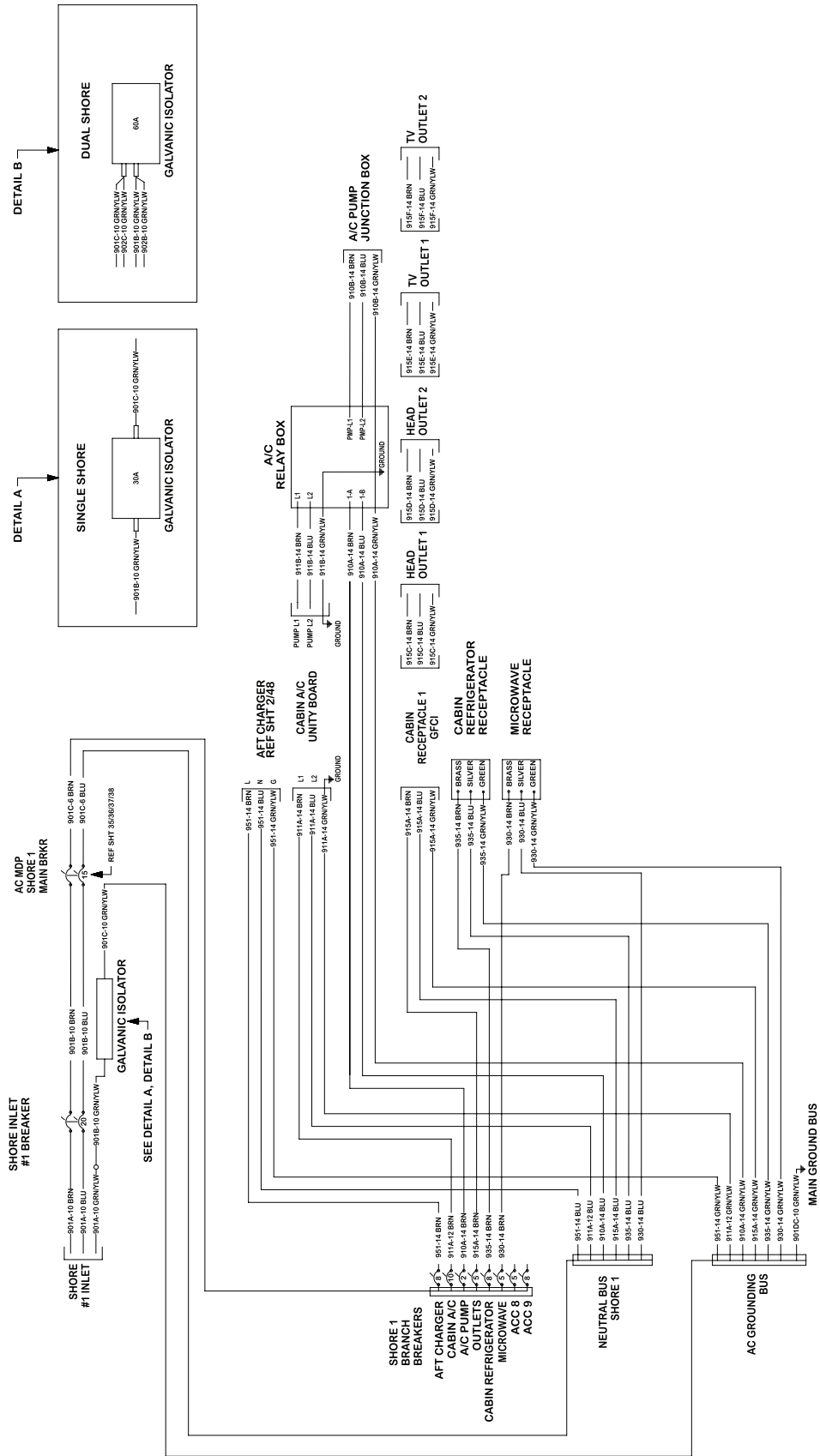

Shore Power 2 AC System 230V/50Hz
(FIGURE 4.77.1)

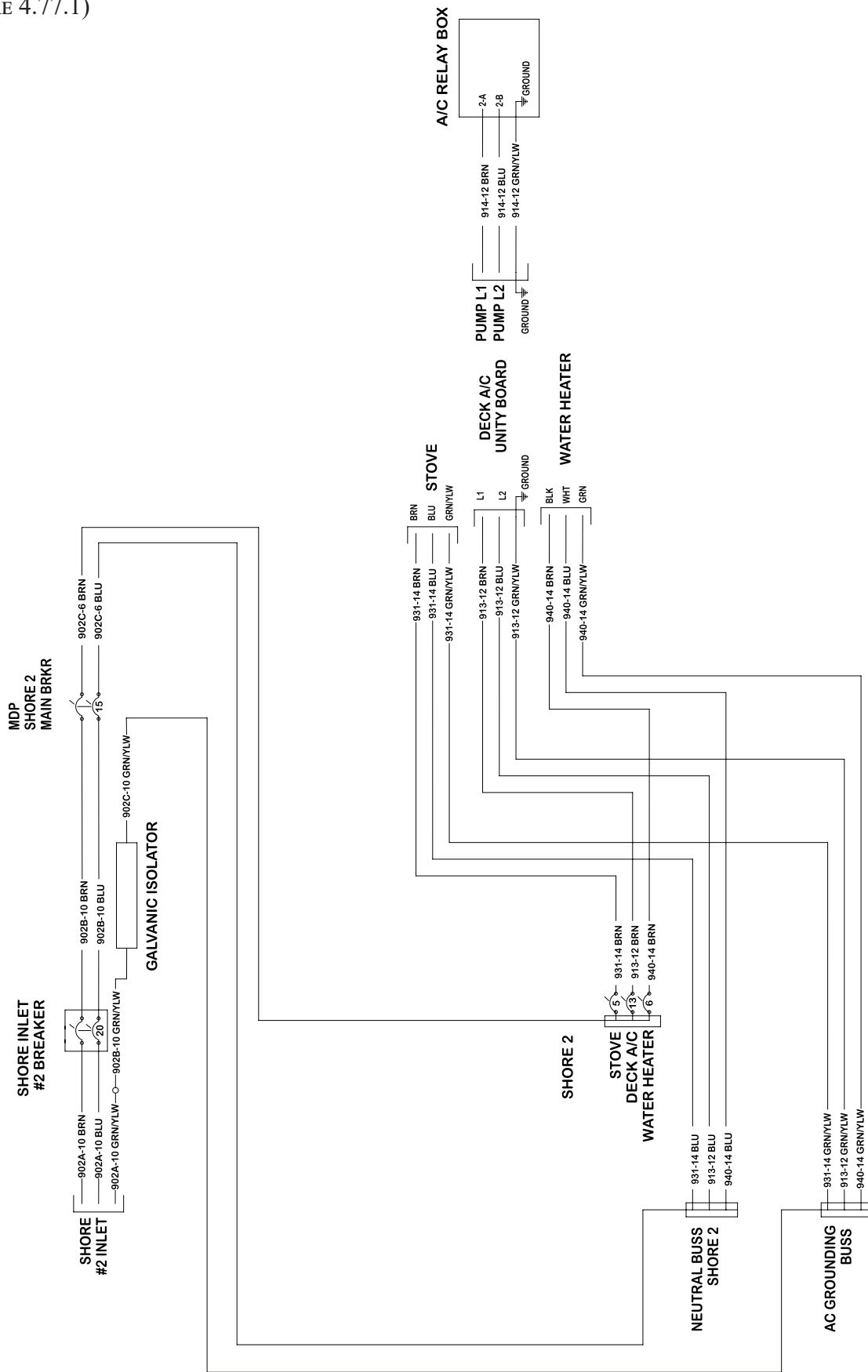

Grill 230VAC and Fridge 12VDC
(FIGURE 4.78.1)

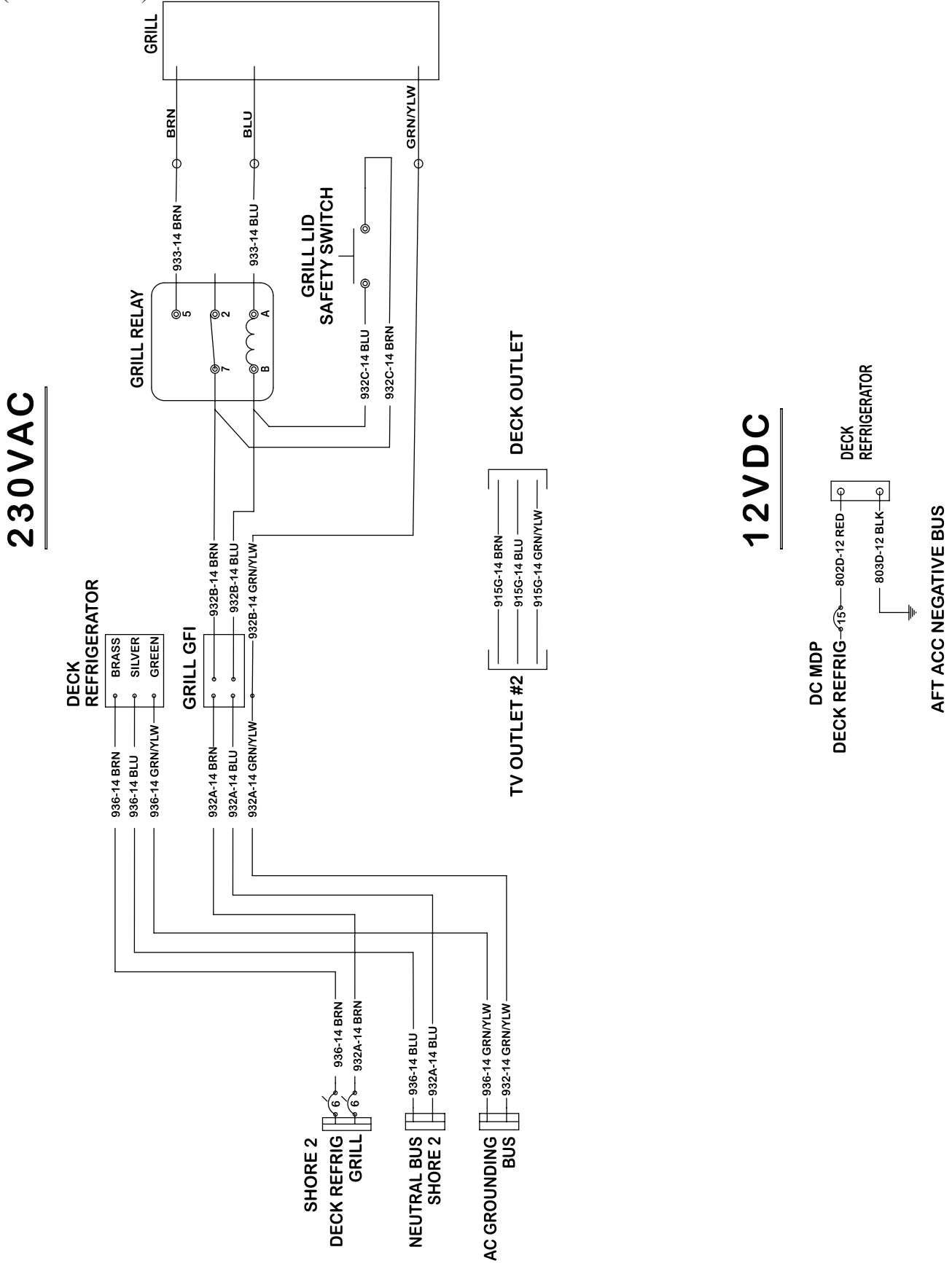

Generator 120V/60Hz AC
(FIGURE 4.79.1)

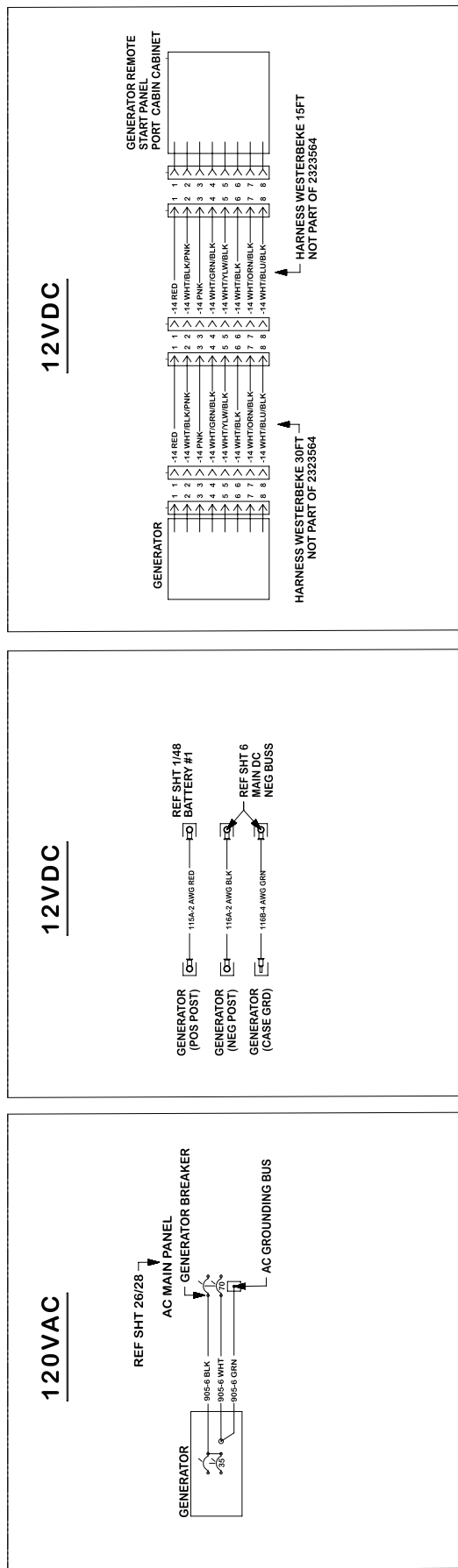

Generator 230V/50Hz AC
(FIGURE 4.80.1)

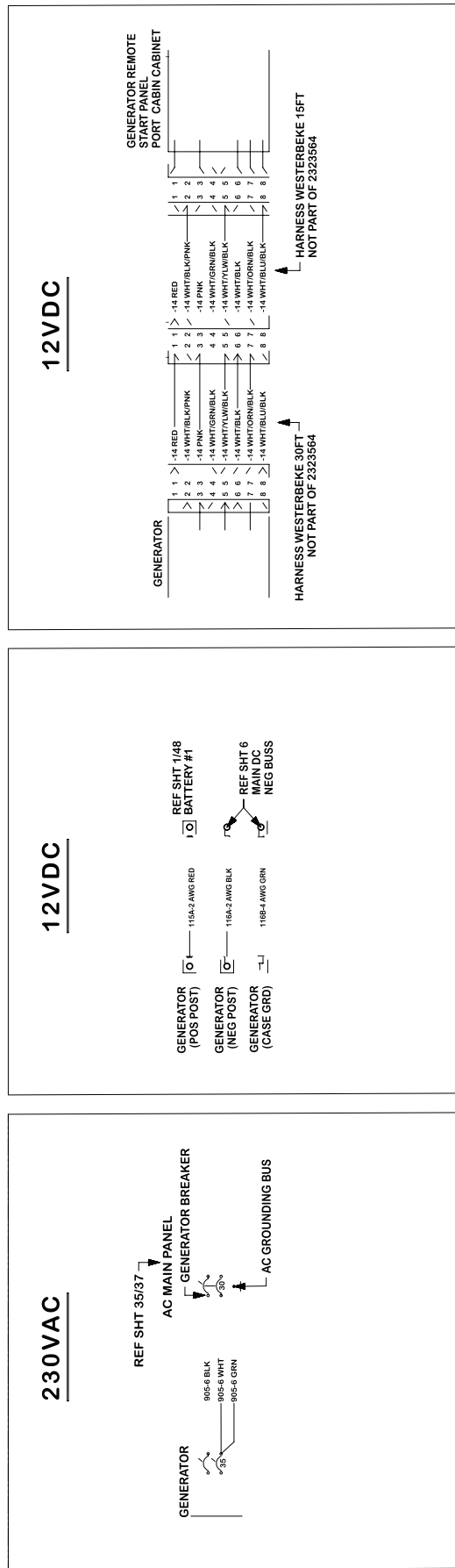

Gyroscopic Stabilizer 120V/60Hz AC
(FIGURE 4.81.1)

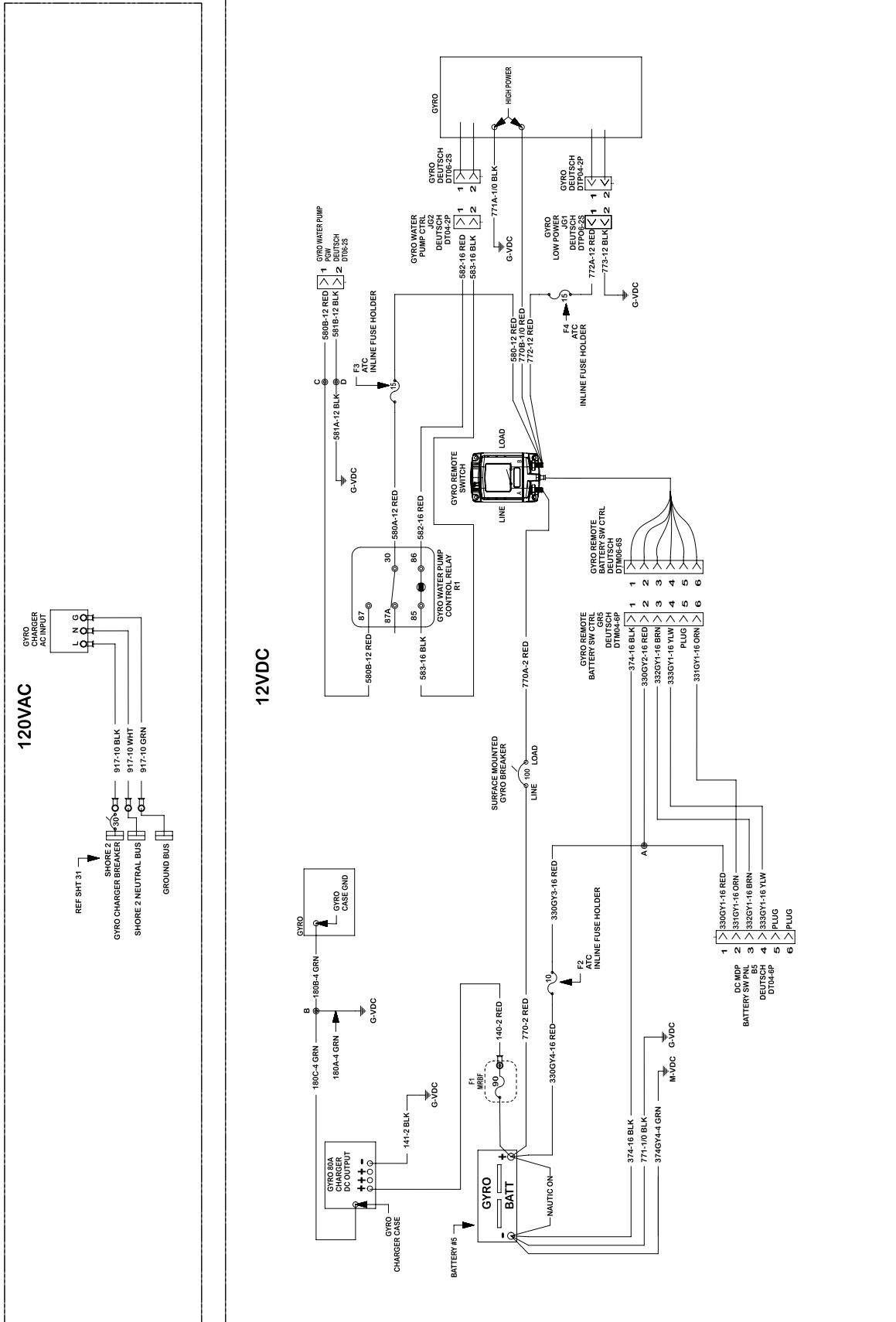

Gyroscopic Stabilizer 230V/50Hz AC (FIGURE 4.82.1)

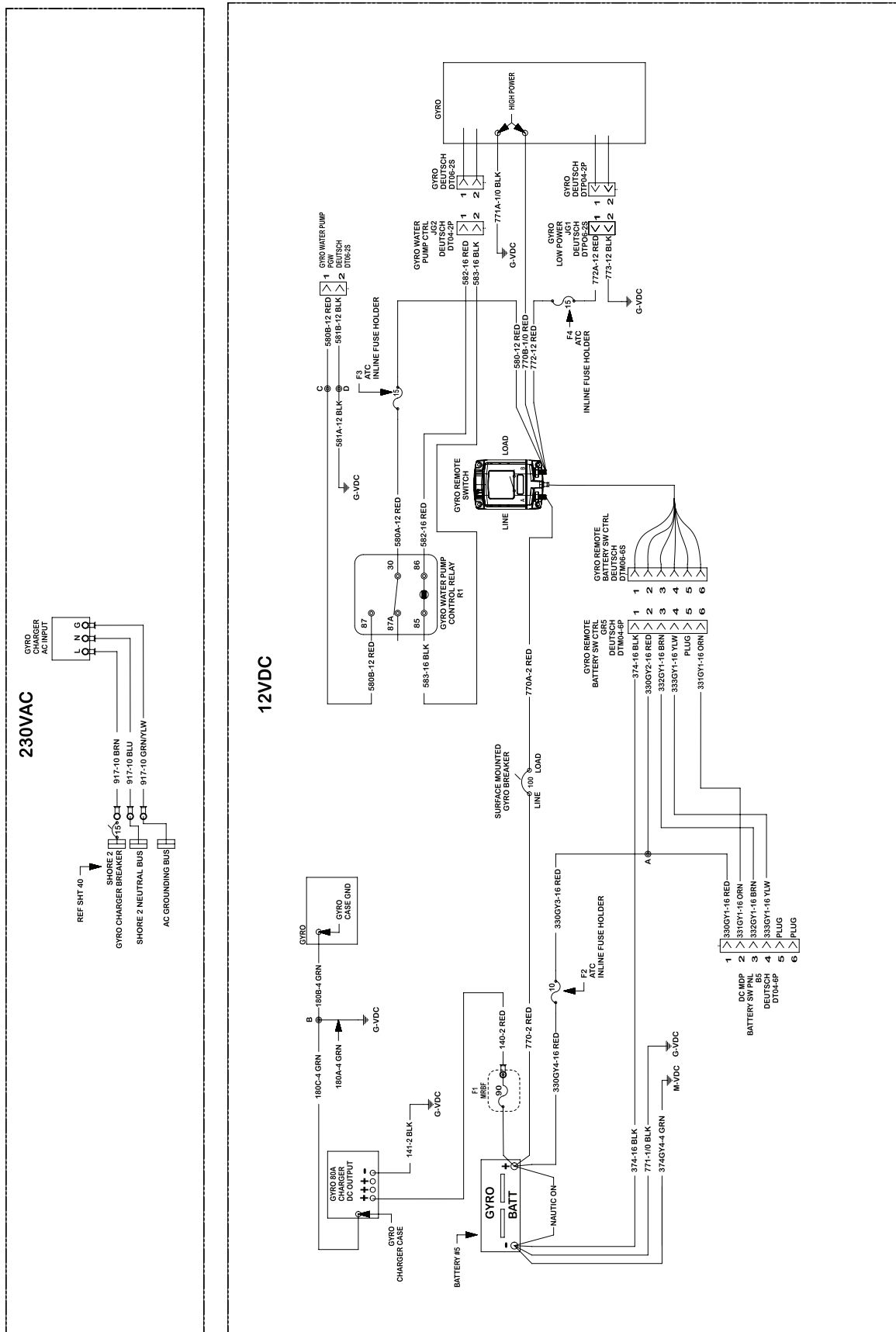

Routine Care and Maintenance

NOTICE

Refer to the individual manufacturers' manuals for important information regarding service, care, and maintenance of this vessel's equipment and components. Failure to do so may in some cases void the warranty.

REFER TO THE OWNER'S PACKET FOR COMPLETE INSTRUCTIONS AND WARRANTY INFORMATION.

⚠ DANGER

When using solvents read all information from the solvent manufacturer regarding safe handling of the material.

Wear proper protective equipment to ensure your personal safety.

Only use solvents in a well-ventilated area and keep all solvents away from open flame and any other forms of ignition.

Routine inspection, service, and maintenance of this vessel, systems, and components are vital to assure your safety, as well as prolonging the life of this vessel. Develop regular routines for inspecting and servicing this vessel.

⚠ WARNING IMPORTANT

Regularly inspect and test hardware, fittings, windshields, hatches, seams, etc., for proper seal. Reseal and/or readjust/tighten as needed.

The interval between necessary service or maintenance is highly variable, depending on the environment where the vessel is used. For example, corrosion of boat parts and components occurs more rapidly in a salt water environment than in fresh water.

This chapter provides only general guidelines for the care and cleaning of this vessel. It is your responsibility to determine whether maintenance and care intervals need to be accelerated due to boat usage and/or operating environment.

Hull

Fresh water, saltwater, and water temperature can all affect the types of growth on this vessel's hull.

Any growth affects the boat's performance and overall look. If it has been a while between inspections you might notice algae or slime growth on the hull. This can be cleaned with a coarse towel or soft bristle brush. The growth should be cleaned immediately after the boat has been removed from the water. If the growth is allowed to dry it will be much harder to remove.

Compounding may be necessary to remove more stubborn stains and chalking from the boat's surface. If compounding is necessary it must be done after a thorough washing and prior to waxing.

If the growth is more severe, you may need to enlist the services of a professional hull-cleaning company.

Check with a Boston Whaler® dealer for recommendations on a compatible rubbing compound for this vessel or a professional hull cleaning company in your area.

Waxing Gel Coat Surfaces

Waxing is necessary to provide added protection to the gel coat. A periodic good cleaning and waxing will also ensure that this vessel will be protected and look good longer.

NOTICE

Waxing of the exterior surfaces is recommended to be done at least twice a year to protect the gel coat of this vessel.

Do not wax over dirt. Make sure the surface of this vessel has received a thorough washing and rinsing and is clean before waxing. If a rubbing compound has been necessary, make sure that any minor scratches or surface pitting are free of compound residue. Use a good quality carnauba wax or a high-quality wax designed for marine gel coat. Apply several coats.

Hull Maintenance

If using a pressure washer to clean the hull and deck surfaces of this vessel it is important to use the wide fan nozzle only and move the spray head in a continuous motion. Do not concentrate the high pressure on a small area of the boat surface and never use the fine pinpoint nozzle as the concentrated stream can cause damage.

Do not pressure wash the console as this may compromise the integrity of the electronics and gauges as well as other equipment installed on this vessel. Also avoid pressure washing all caulk seams.

When staining from build-up does occur, use only cleaning agents recommended for marine gel coat. Never use an abrasive cleaner to wash this vessel's hull. Never use an abrasive pad to attempt to remove stubborn stains. Never use strong solvents to clean. Never apply tape or any other type of adhesives directly to the painted surfaces on this vessel.

Use care when covering this vessel's painted surfaces as tarps and other such covers can trap dirt and cause chafing. It is best to use a frame of either aluminum or wood to keep the cover up and allow air to circulate.

Hull Blistering

Due to the quality of the materials used in the hull, blistering is rarely ever seen. Blistering is caused by water soluble materials in the hull laminate. The fiberglass and resin structure of this vessel is porous. However, intrusion of water into the gel coat will take some time. The effect of osmotic pressure allows water to impregnate below the gel coat and substrate thus forming a blister.

There have been extensive university studies funded by the United States Coast Guard regarding the cause and effect of blistering in the gel coat of fiberglass boats. Fiberglass blisters can form anywhere from near-surface layers of the gel coat to very deep into the fiberglass structure. Damage can range from cosmetic to catastrophic, although the latter is very rare. Studies seem to point to long-term immersion of the hull in warm water as a primary cause of hull blisters. Stress cracks on the hull below the waterline also contribute to the formation of hull blisters.

Prevention

There are a variety of ways to prevent the formation of hull blistering. Epoxy coatings can be applied to hulls, followed by hull painting. An alkyd-urethane-silicone marine paint can also be used to aid in the prevention of hull blisters.

Reducing the amount of time that this vessel stays in the water also helps prevent hull blisters from forming. Use of a trailer or boat lift reduces the likelihood of hull blisters forming. Be sure to use a bunk type lift or trailer for storage of the boat out of water. Contact your Boston Whaler dealer for more information on the prevention and treatment of hull blisters.

Anodes

Sacrificial anodes are installed on this vessel's trim tabs and engines to protect metallic parts from corrosion damage.

Anodes must be replaced regularly. Inspect your anodes often and replace when the anode is approximately 50 percent deteriorated. If an increase in anode consumption is noticed, there may be an electrical issue that needs to be addressed on your vessel or a neighboring boat. Contact a qualified marine electrician.



CAUTION

Do not paint over sacrificial anodes. This action renders them useless and leads to deterioration of the underwater metal parts of this vessel.

Deck

Clean up any oil spills on the deck with soap, hot water, and a stiff brush.

Bottom Painting

DANGER

There are risks and dangers inherent with the use of paints and solvents. Dispose properly of all rags, rollers, and trays used for painting. Follow all the precautions and regulations listed by the manufacturer before and after painting this vessel's hull.

NOTICE

If blisters are present in the hull, they need to be properly cleaned and dried out before any barrier protection can be applied.

CAUTION

Some bottom paints contain metals that can cause corrosion of outboard engines. Leave a minimum of 3/4" unpainted surface around all engine parts. Use only paints specifically designed for aluminum engines as anti-fouling protection.

If this vessel will spend most of its time in the water, painting the bottom of this vessel's hull is a good way to slow the formation of hull blisters and to keep bottom growth (fouling) under control. Conversely, if you will be trailering the boat to and from the water, you might want to forgo the painting.

The following is an abbreviated section on painting the hull bottom. Your Boston Whaler dealer should have information on properly painting this vessel's hull or recommendations on businesses that specialize in this area.

Bare Hull Painting

Proper preparation is the key to successful hull painting. Begin by scrubbing the surface thoroughly with a stiff brush using an all-purpose marine soap and water to remove loose dirt and contamination. Flush with fresh water to remove all soap residue.

The gelcoat must be dewaxed of mold-release wax before sanding can begin, otherwise wax will be deposited in the scratches and reduce the adhesion properties of the paint.

WARNING

Proper ventilation and capture of the dust created by sanding is essential. The dust created by sanding is toxic and should not be inhaled. A proper fitting respirator must be used. Do not use a paper filter mask.

Remove any mold-release wax that may be present using fiberglass surface prep solvent and a scrub pad. Scrub only a few square feet at a time. Flush with fresh water. If the water beads up or separates, continue scrubbing the surface. When the water sheets off, the wax contaminate has been removed.

After the dewaxing is complete, application of a primer coat is recommended. Pay close attention to scratches, nicks and dings in the surface. If necessary, fill any repair areas with a watertite-epoxy filler. After filler is cured, sand with 80 grit paper until smooth. Remove the sanding residue using a fiberglass solvent wash. Paint can be applied after sanding and cleaning is complete. Follow the paint manufacturer's recommendations for application.

Bottom Painting a Pre-Painted Hull

WARNING

Bottom paint is designed to resist algae growth which means it has chemicals embedded in the paint that are harmful if ingested. Take all necessary precautions required before painting or repainting this vessel's hull.

If the hull bottom is already painted, test the paint's adhesion to the painted surface. If the paints are incompatible, the new paint will not adhere to the hull bottom or the paint will lift the old paint. Never apply paint without first preparing the old painted surface. Follow the paint manufacturer's recommendations. Thin layers are better than one thick layer.

NOTICE

Painting this vessel's hull will adversely affect the boat's speed and performance and may require re-propping if the maximum engine RPMs drop below the engine model/manufacturer recommended operating range.

Humidity and weather play a role in how and when paint should be applied. To determine the waterline, place the boat in water with a full load of fuel and gear. Mark the waterline and measure above the marked line 1” to 3” for placement of the tape line. Make sure that there is enough paint left to cover areas that were not accessible (slings, jack stands etc.) and paint accordingly. Follow the paint manufacturer’s recommendation for do’s and don’ts after painting is complete.

NOTICE

The use of masking tape is not recommended for hull-bottom paints.

Rubrail Care

The rubrail on this vessel is constructed of an injected high density PVC vinyl material which laboratory tests have proven to be highly resistant to staining, fading and cracking. As resilient as this material is, you still need to follow some basic maintenance precautions. General maintenance requires a thorough cleaning with mild soap and water. Do not use any cleaning agents which contain chemicals.

Although the outer shell is tough and durable, there is a chance that it can be breached. Use care when docking or exposing the rubrail to conditions which may cause damage such as docking against heavily barnacle-encrusted pilings. Some tears (cleanly sliced) can be repaired with a super glue-type product. Thoroughly clean and dry the affected area. Apply glue and hold the surfaces together. Areas which have been torn or are affected by heavy abrasion must have the damaged section replaced. Please see a Boston Whaler dealer for this type of repair.

Cleaning Fiberglass and Non-Skid

To protect your deck and non-skid areas from the deteriorating affects of the sun, oxidation, water spots, and pollution, use a good quality fiberglass and non-skid deck wax every two to three months. When applied to deck and non-skid areas the wax forms a protective non-slick surface which keeps debris from sticking. Dirt, soot, bird droppings, and fish blood rinse right off. Follow the wax manufacturer’s detailed instructions.

NOTICE

Never use abrasive cleaners, detergents or soft scrub type cleaners to wash this vessels surfaces.

Never use abrasive pads, brushes or sponges to attempt to remove stubborn stains.

Never use strong solvents or detergents which contain chlorine.

Stainless Steel Care

NOTICE

Never use abrasive cleaners, detergents or soft-scrub type cleaners to wash boat surfaces.

Never use abrasive pads, brushes or sponges to remove stubborn stains.

Never use strong solvents or detergents which contain chlorine.

Never use silver cleaners.

The cleaner your stainless trim and fittings can be kept, the greater the assurance of optimum corrosion resistance. Without proper care even the best stainless steel will corrode.

Stainless steel is strong and corrosion resistant, but still requires maintenance to keep its appearance. Frequent routine cleaning of stainless steel with a mild soap and water solution - and coating with a quality cleaning wax - helps maintain the finish.

- Wash with mild soap and cold water.
- Dry thoroughly.
- Apply cleaning wax with a soft, dry cloth.
- Allow wax to dry, then polish and buff.

Even the finest cleaning powders can scratch or burnish a mill-rolled surface. On polished finishes, rubbing or wiping should be done in the direction of the polish lines, Not across them.

Crevice corrosion, a brownish coloring which occurs where two pieces of stainless hardware meet, is caused by impurities in water and air. It can be easily cleaned with a marine-grade polish using a

sponge, cloth or small bristled brush for the nooks and crannies.

Teak Maintenance

The teak on this vessel requires some maintenance. Boston Whaler uses both natural teak and coated teak (pre-lacquered). Do not use a steel brush, steel wool, or a pressure washer on the wood. Do not use strong solvents or harsh cleaners on the caulking as these can damage or dissolve the caulk. Depending on the options selected for this vessel, different maintenance options apply:

Let It be (Natural Teak)

Left alone with the elements, teak changes to a silver-grey patina. To maintain, occasionally wash with soap and water. A light sanding every few years keeps the surface smooth; always sand with the wood grain.

Oiling

To retain or increase the darkness of the wood, apply a teak oil. There are numerous products on the market that provide a variety of different characteristics. Refer to the manufacturer's instructions for proper application.

Lacquering

Applying lacquer to teak may decrease the amount of maintenance required and reduces the risk of mold. Lacquers can be tinted to change the color of the finish and can be mixed with paint thinner to reduce shine. Wood will likely darken when clear lacquer is applied. Carefully research product information to ensure it's suitable for both teak and caulk. Refer to the manufacturer's instructions for proper application.

Coated Teak (Pre-lacquered)

If this vessel has a coated (pre-lacquered) table(s), keep covered when not in use. Be sure to allow for air flow between the table and the cover by inserting a non-marring object between the two. Refer to the manufacturer's instructions for proper care.

Seats (Mechanical Parts)

Always wash metallic parts with soap and water and rinse thoroughly with fresh water. Once dry, apply a light coating of lubricant to protect moving parts.

Check for loose or damaged hardware and tighten or

replace as necessary.

Aluminum Care

Preventative maintenance is essential to life of the metals on this vessel. The presence of salt particles and moisture is the major cause of white spots, pitting and corrosion.

The use of harsh chemicals can also cause deterioration. Manufacturers and applicators of protective coatings will not warranty protective coatings on metals in the marine environment. Proper owner maintenance is required to reduce deterioration which results in most cases by failure to wash down and wipe dry after each use and/or the use of abrasive, acidic or other improper cleaners.

Wash completely using a soft cloth and mild detergent to remove salt particles. Hosing alone will not dislodge all particles. Do not allow soap to dry as it may cause stains on coated surfaces. Make sure to wash and dry the full circumference of aluminum parts.

Apply an aluminum protectant at least twice each year - more frequently as conditions warrant. Neglect will cause pitting of the surface which cannot be reversed.

Inspect and repair or replace all damaged nylon bushings, washers or other hardware designed to prevent contact with dissimilar metals.

Whenever electrical or electronic changes are made to the boat, a qualified-marine technician should check aluminum parts for stray currents. Make sure all electronic equipment is properly grounded with adequately-sized wire.

Cushions

Saltwater, salt residue, dirt and ultra-violet rays will take their toll on vinyl products causing them to lose their luster and texture. To clean cushions:

- Remove ordinary dirt and smudges with a mild soap and water solution. Dry with a soft, lint-free cloth or towel.
- More difficult stains can be cleaned using rubbing alcohol. Rinse cleaned area with fresh water and dry with a clean, soft, lint-free cloth or towel.
- Seemingly permanent stains like ballpoint ink can be cleaned with active solvents such as nail polish remover when applied with a soft cloth or damp sponge and rubbed. Rinse cleaned area with fresh water and dry with a clean, soft, lint-free cloth or towel.

The vinyl material and superior finish of cushions has been tested to resist heavy abrasion. Read all information provided by the cushion manufacturer regarding the proper cleaning and maintenance.

REFER TO THE OWNER'S PACKET FOR COMPLETE INSTRUCTIONS AND WARRANTY INFORMATION.

Boat cushions are not waterproof. They are constructed of open-cell foam and will absorb and hold water. Do not leave the cushions in standing water or exposed to heavy, prolonged rain. If cushions become waterlogged, remove the foam from the cushion, press out as much water as possible from the foam and allow to air dry.

To prevent mildew, keep the vinyl dry and make sure that moisture does not accumulate between the cushions.



CAUTION

Wear rubber gloves when using any solvents. Use caution when cleaning around buttons, stitching, and wooden or decorative trim as solvents could seriously damage such areas.

Cleaning Instrument Gauges

When gauges are exposed to a saltwater environment, salt crystals may form on the bezel and plastic covers. Remove salt crystals with a soft damp cloth. Clean with a mild household detergent or plastic cleaner. Never use abrasive solvents or dirty rags to clean plastic parts. A mild household detergent or plastic cleaner should be used. Wipe clean with a damp chamois. For more information, contact Mercury Marine customer service at 920-929-5040.

Canvas Care and Maintenance

NOTICE

Do not use detergents, bleach or solvents to clean your canvas.

To keep canvas in good condition it should be cleaned regularly before dirt, pollen, etc. are allowed to accumulate on and become embedded in the fabric. Canvas can be cleaned without being removed. Chafing, fiber wear from dirt and grit and deterioration from ultraviolet light can cause your canvas to degrade over time.

Maintaining Appearance

After each use, especially if used in salt water areas, rinse the canvas completely with fresh cold water.

To maintain canvas:

- Brush off any loose dirt, pollen, etc.
- Hose down with fresh cold water and clean with a mild solution of a natural soap in lukewarm water (maximum 100°F / 38°C).
- Allow canvas to soak. Do not allow soap to dry.
- Rinse thoroughly with fresh water.
- Let canvas dry completely. Do not store canvas while wet.

The effects of ultraviolet light can sometimes be reduced by chemical treatment of canvas items. Consult a Boston Whaler dealer or check the canvas manufacturer's instructions before using any chemical treatment on canvas.

REFER TO THE OWNER'S PACKET FOR COMPLETE INSTRUCTIONS AND WARRANTY INFORMATION.

Stubborn Canvas Stains

Soak fabric for approximately twenty minutes in a mild solution consisting of no more than 1/2 cup of bleach and 1/4 cup of natural soap per gallon of lukewarm water (not to exceed 100° F / 38° C). Rinse thoroughly in cold water several times. Allow the fabric to air dry completely.

NOTICE

Failure to remove all of the soap solution can cause deterioration of seams and prevent fabric from proper retreating.

Retreat the fabric using an air-curing product such as *303 High Tech Fabric Guard* to ensure water and stain repellency. All canvas should be stored flat or rolled in a clean, dry space.

Canvas Zippers and Hardware

Lubricate zippers and fasteners periodically with a clear silicone spray. A wax candle can also be used to lubricate the zipper track. Replace any missing or corroded fasteners.

NOTICE

Do not use petroleum based products, such as petroleum jelly, on the zippers or fasteners.

Vinyl Windows

The canvas on this vessel may incorporate Eisenglass or Makrolon® polycarbonate windows. Regular cleaning, utilizing compatible cleaners, coupled with proper maintenance improves the vinyl's service life.

NOTICE

- **Never use window cleaners, detergents, abrasives, petroleum-based products, or alcohol to clean vinyl windows.**
- **Do not handle vinyl with sunscreen on your hands. Sunscreen permanently clouds vinyl where handled.**
- **Do not fold vinyl. Store flat or rolled with smooth paper or soft cloth (like a bed sheet) between layers when dry.**

- Rinse vinyl thoroughly with fresh water to remove any dust, dirt particles, salt water or environmental agents before applying cleaning products. This should be done frequently to avoid build up of salt water, dirt and other environmental contaminants.
- Using a soft non-abrasive cloth, wash windows inside and out with a mild soap and water solution. Rinse completely with cool water.
- Do not use detergents.
- Use separate clean, soft cloths or sponges for application of cleaners and polishes. Use a small amount of cleaner or streaking may occur. If streaking or a film occurs, follow up application with a water rinse.

REFER TO THE OWNER'S PACKET FOR COMPLETE INSTRUCTIONS AND WARRANTY INFORMATION.

Cleaning Tempered Glass Windshield

NOTICE

Do not use abrasives, harsh chemicals or metal scrapers on glass.

Use commercially available glass cleaners or a mixture of fresh water and vinegar to clean glass windows, windshield or port lights. Dry with a soft terry cloth towel or chamois.

Long-term Storage and Winterization

Long periods of storage, winter lay-up and/or non-use, common to boats, create unique problems. When preparing to store a boat for extended periods of two months or more it is best to make sure that the boat and its systems are properly conditioned for such extended periods of non-usage. Follow the guidelines on winterizing this vessel and the boat's systems. If inexperienced with the process of winterization it is best to hire the services of a professional.

REFER TO THE OWNER'S PACKET FOR COMPLETE INSTRUCTIONS AND WARRANTY INFORMATION.

Engine

CAUTION

Never start or run an outboard (even momentarily) without having water circulating through the water-intake holes in the gear case. This will prevent damage to the water pump (running dry) or overheating of the engine.

Protecting your engine's vital moving parts from corrosion caused by freezing of trapped water or excessive condensation due to climatic changes is very important. Freezing water in the engine can cause extensive damage to the internal moving parts. Internal engine parts can also be affected by rust due to lack of proper lubrication. To maintain:

- Replace engine oil and filter, running the engine to drain as much old oil as possible.
- Flush engine with fresh water using flush mufflers or similar device attached to raw water pickup.
- Let all water drain from engine.
- Fog engine while running. Spray until it stalls.
- Run fuel which has been treated with conditioner and stabilizer through engine.
- Replace lower unit gear oil. Check for moisture in old oil, a sign of deteriorating seals.
- Remove prop and grease shaft and threads.
- Treat all grease fittings with manufacturer-recommended lubricant.
- Lightly lubricate exterior of engine or polish with a good wax.
- Check engine mount bolts. Ensure they are torqued to 55 ft/lbs.
- Fill tank to capacity; add fuel stabilizer/conditioner.

REFER TO THE OWNER'S PACKET FOR COMPLETE INSTRUCTIONS AND WARRANTY INFORMATION.

Fuel System

Treat tank(s), hoses, and fuel pumps to help prevent the formation of varnish and gum. Temperature extremes will cause condensation to accumulate in an empty or partially-filled fuel tank leading to fuel contamination and/or premature wear of your system.

Inspect your fuel system annually for leaks. You should check the fuel-tank area below the floor for liquid fuel, or a strong odor of gasoline before each outing, but at least once a year you should open each access port to any of the fuel-system components to inspect for leakage. If any leakage or seeping of fuel around any fuel-system fitting is found, or there is a strong odor of gasoline, do not turn on or off any electrical appliances or attempt to start this vessel; open all hatches to allow the compartment to ventilate, and call a qualified service/repair person for inspection and repair of the leak before using this vessel.

Fresh Water System

If the water system won't be used for an extended amount of time it is recommended that it be drained. To drain:

- Press *Freshwater* pump switch on main distribution panel (under companion lounge seating) to start pump.
- Open all faucets, sprayers, and wash-down connections.
- Run system until tank is completely empty.
- Press *Freshwater* pump switch again to stop pump.
- Add a non-toxic antifreeze to freshwater tank per manufacturer's recommendations.
- Press *Freshwater* pump switch again to start pump.
- Run system until antifreeze is seen running out of all faucets, sprayers, and wash-down connections.
- Close all faucets, wash-down connections and sprayers.
- Press *Freshwater* pump switch again to stop pump.

If a water heater is a part of the system, isolate the tank by disconnecting the in and out hoses and connecting them together. Make sure that the tank contains a sufficient amount of non-toxic antifreeze to avoid freezing and causing damage. Do not run the water heater without water in the unit.

Freshwater System Disinfection

After initial installation of the freshwater system, system component replacement, or long-term storage, it is vital that it be properly disinfected. To disinfect:

- Flush entire system thoroughly by allowing potable water to flow through it.
- Drain system completely.
- Fill entire system with a chlorine solution strength of at least 100 parts per million. Allow to stand for one hour
- Drain entire system.
- Flush system thoroughly with potable water.
- Fill with potable water.

Head System

- Pump out holding tank at an approved facility.
- Add fresh water to bowl and flush several times while holding tank is being pumped.
- Use cleaning/sanitizing crystals or liquid, following manufacturer's recommendations, and let soak for a few minutes.
- Add fresh water and flush several times while pumping out holding tank again.
- Add antifreeze and flush/fill entire system.

Electrical System

- Check all connections and tighten if necessary.
- Spray connections with an anti-corrosion spray.

Battery

NOTICE

Follow the manufacturer's recommendations for long term storage of your battery(s).

Engine and house electrical systems are reliant on a good source of power. The house source of power typically comes from a battery bank comprised of two or three batteries in parallel. The charging source for the batteries while away from the dock is the engines; or if equipped a generator. And when the

generator is on, the battery chargers. Keep in mind the following battery recommendations.

Mixing Fresh/New and Used/Dead Batteries

The fresh battery will deliver current into a dead battery which has high resistance. This results in excessive heat in the used/dead battery, which can cause further damage, leakage, or rupture. A used battery will drain energy from the new one, reducing the total amount of battery power available.

Mixing Battery Types

Different battery types are designed for different purposes. Mixing an AGM battery with a lead-acid battery will not improve performance and instead may result in reduced performance, damaged equipment, or battery leakage or rupture.

Mixing Battery Brands

Different battery brands may not have the same specifications like marine cranking amps (MCA) or cold cranking amps (CCA). This results in excessive heat, which may cause damage, leakage or battery rupture. Use the same type of batteries throughout the boat.

Long-term Battery Storage

NOTICE

Remove battery from boat and store in a cool, dry location. Periodically check the battery during long term storage.

- Disconnect battery cables (negative first).
- Remove battery from boat.
- Clean terminal ends of cables and battery terminals with a solution of baking soda and water. Rinse thoroughly with clean water.
- Apply a coat of dielectric grease on terminal ends of cables and battery terminals.
- Store battery in a cool, dry area.
- Use a trickle charger to keep battery charged or charge battery every 30-60 days.

Drainage

It is important to raise the bow of the boat enough to allow for proper drainage of water from the deck and bilge area. Make sure all the drainage fittings are clear and free of debris and plugs are removed. Store the engine in an upright position to promote adequate drainage of water.

Avoid Loss

Remove any valuables or anything that can be easily removed from the boat such as electronics, lines, PFDs, fenders, cushions, etc., and store at home.

Cover

When covering this vessel it is best to use a frame of either aluminum or wood to keep the cover up. This allows air to circulate and discourages water from pooling on the cover. Vents along the entire length of the cover will allow condensation to escape. Placing a series of foam pads between the hull and cover will also aid in air circulation and reduce condensation.

To help keep this vessel dry and mildew free, consider placing commercial odor and moisture absorbing products in the boat under the cover.

NOTICE

Do not use a bimini top in lieu of a cover. Damage and aging will occur while providing no protection for this vessel.

Trailer Storage

Repeatedly immersing the trailer in water during boat launching can cause a variety of problems. Water seeping into the wheel hubs will cause the grease to emulsify and can prematurely corrode the bearings. Check with the trailer manufacturer for scheduled maintenance of your trailer.

REFER TO THE OWNER'S PACKET FOR COMPLETE INSTRUCTIONS AND WARRANTY INFORMATION.

Environment

Antifreeze and other winterizing fluids can be toxic to aquatic life and cause harmful effects to plant life. Improper disposal of, or spillage of antifreeze and/or any winterization fluids can cause environmental

problems when allowed to empty into waterways or on the ground. Furthermore, it is illegal, punishable at minimum by fines. Used antifreeze or any winterization fluids, should not be disposed of into sanitary sewers or publicly owned treatment plants.

Questions regarding recycling antifreeze or other toxic fluids should be directed to your state's EPA office.

Reinforcement Locations

This vessel has been manufactured with reinforcement in various locations throughout the deck (see Figures 5.11.1 and 5.12.1). In the event you wish to add equipment to this vessel which requires you to penetrate the deck with fasteners, the diagram above illustrates the size, location and type of the reinforcement available. The chart below provides a description of the material and recommended fasteners to secure your equipment.

CAUTION

Do not attempt to secure equipment in any location other than those illustrated.

Chapter 5 • Care and Maintenance

Reinforcement Material and Locations

Figure 5.11.1

Reinforcement	Construction	Equipment weight	Fastener Type*
Plywood	Standard boat-building material	Light	Self-tapping screws
Trevira	Thick spunbound-polyester fabric	Light	Sheet Metal screws
Sparalloy	High-density plastic	Medium	Self-tapping screws
Phenolic**	Reinforced-composite board	Heavy	Drill & Tap

* In all cases it is recommended to drill and countersink a pilot hole to prevent damage to the gelcoat surface.

**Also known as Whaleboard

Reinforcement Location Dimensions (see Figure 5.12.1)

1	1/2" phenolic 2" × 7"	20	1/2" phenolic 2" × 4"	39	1/2" plywood 3" × 11"
2	1/2" phenolic 3.125" × 16.625"	21	1/2" plywood 5" × 8"	40	1/2" plywood 6.75" × 11"
3	1/2" phenolic 8.625" × 9.125"	22	1/2" plywood 8" × 13"	41	1/2" plywood 3.375" × 11"
4	3/8" phenolic 2" × 12"	23	1/2" plywood 7.5" × 13.75"	42	1/2" plywood 2.25" × 4.75"
5	1/2" plywood 4.5" × 8"	24	1/2" plywood 6" × 8"	43	1/2" plywood 2.25" × 7.125"
6	1/2" plywood 5" × 6"	25	3/8" phenolic 2" × 3"	44	1/2" phenolic 8" × 8"
7	3/8" phenolic 2.5" × 5.25"	26	1/2" plywood 2" × 5"	45	1/2" phenolic 3.5" × 3"
8	3/8" plywood 1.25" × 10.375"	27	1/2" plywood 3.25" × 4.5"	46	1/2" phenolic 2" × 5"
9	3/8" phenolic 1" × 3"	28	1/2" phenolic 12.5" × 12.5"	47	3/8" phenolic 3" × 6"
10	3/8" phenolic 5" × 5"	29	1/4" plywood 3.875" × 10.25"	48	1/4" plywood 1.25" × 20.5"
11	1/2" plywood 2" × 3"	30	1/2" plywood 3.25" × 4"	49	1/2" plywood 1.625" × 19.125"
12	3/8" phenolic 14" × 15.25"	31	1/2" plywood 4" × 8"	50	1/2" plywood 2.25" × 23.25"
13	1/2" phenolic 14.125" × 19"	32	1/2" plywood 1.25" × 3"	51	3/8" phenolic 1.5" × 10"
14	1/2" plywood 3" × 6"	33	1/2" plywood 5" × 8"	52	1/2" phenolic 1.75" × 1.875"
15	1/2" plywood 3" × 3"	34	1/2" phenolic 4" × 21.375"	53	1/2" plywood 8.125" × 8.625"
16	1/2" plywood 3.5" × 3.5"	35	1/2" phenolic 6.5" × 21.375"	54	3/4" plywood 4" × 7"
17	1/2" phenolic 2" × 3"	36	1/2" phenolic 3" × 7.75"	55	1/2" phenolic 4.5" × 5"
18	1/2" plywood 1" × 20"	37	1/2" phenolic 3" × 5.5"	56	1/2" phenolic 4" × 5"
19	1/2" phenolic 3" × 5"	38	1/2" phenolic 3" × 7"		

Reinforcement Locations
Figure 5.12.1

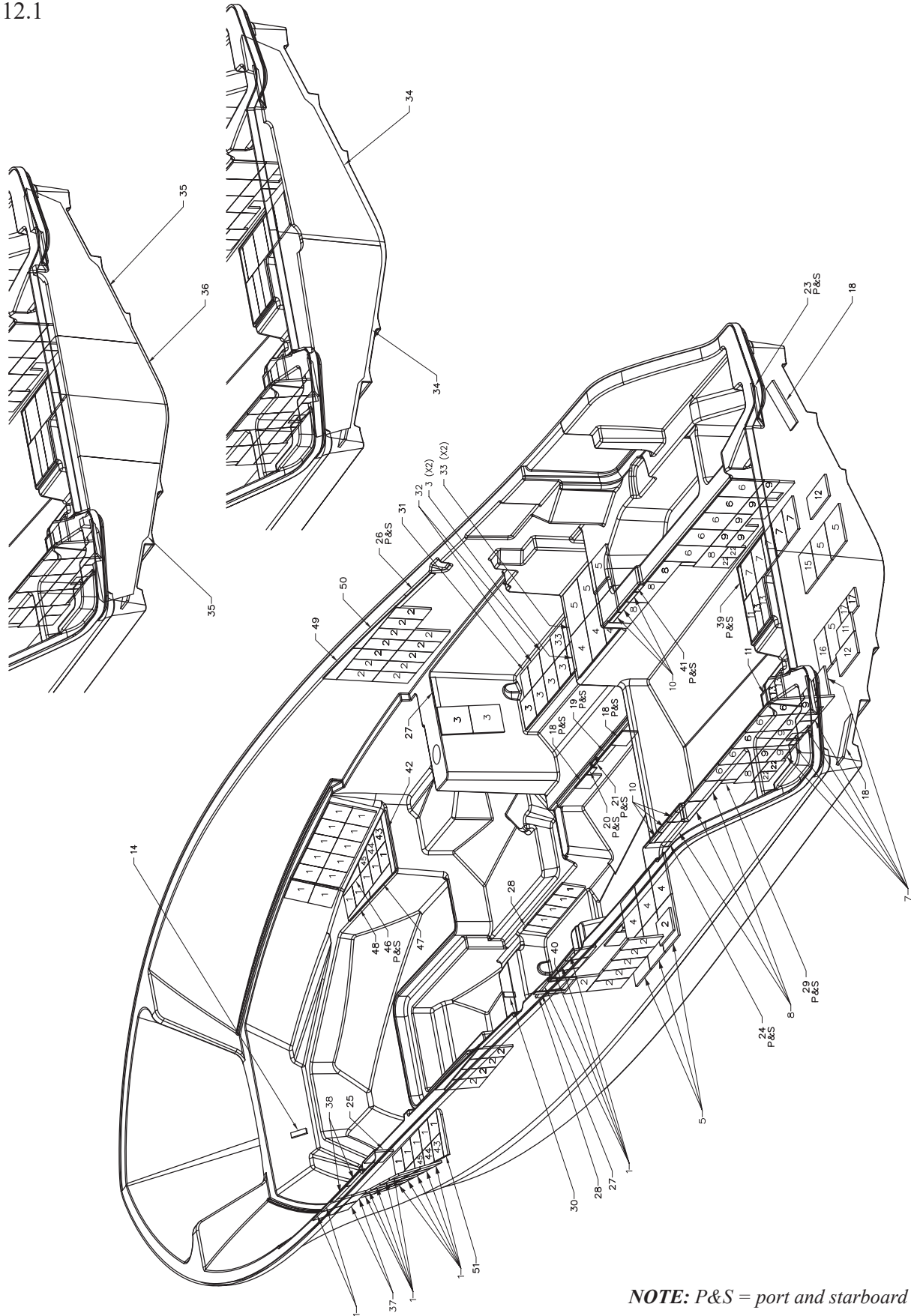

NOTE: P&S = port and starboard