

# 250 Dauntless

*Owner's Manual*



THE UNSINKABLE LEGEND

# ***250 Dauntless***



**The mission of Boston Whaler® is to provide consumers with the safest, highest quality, most durable boats in the world.**

 **WARNING**

Operating, servicing and maintaining a recreational marine vessel can expose you to chemicals including engine exhaust, carbon monoxide, phthalates, and lead, which are known to the State of California to cause cancer and birth defects or other reproductive harm. To minimize exposure, avoid breathing exhaust, service your vessel in a well-ventilated area and wear gloves or wash your hands frequently when servicing this vessel. For more information go to [www.P65warnings.ca.gov/marine](http://www.P65warnings.ca.gov/marine).

# Introduction

---



T H E U N S I N K A B L E L E G E N D™

Welcome to the Boston Whaler® family and congratulations on your purchase!

For over six decades, Boston Whaler has engineered the most reliable and forward-thinking boats on the water. Every chapter of our history starts with a belief in pushing the limits of what's possible, and this heritage is cause for both reflection and celebration.

Standing behind every Whaler is an extremely qualified network of dealers to provide you with a truly exceptional boating experience. Information and assistance is also available at [bostonwhaler.com](http://bostonwhaler.com), where you'll find customer resources including how-to videos, maintenance tips, and other technical content. While there, don't forget to sign up to receive Boston Whaler's lifestyle magazine, Whaler.

Since Boston Whaler's inception in 1958, we are committed to providing customers with the safest, highest-quality, most-durable boats in the world. We are confident that as a Whaler owner you will love the quality and pride that is built into every boat.

From all of us here at Whaler, thank you for selecting one of our a legendary and innovative boats. May that choice bring you a lifetime of boating enjoyment.

# Introduction

---

## HISTORY

Since our founding more than 60 years ago, Boston Whaler® has conceived and built peerless designs that meet boaters' diverse and changing needs. It all began in Braintree, Massachusetts with founder Richard Fisher's inspired new construction method featuring two significant innovations: first, a twin sponson hull design that resulted in superior stability and a remarkably dry ride, and second, a unique foam core construction that made the boat not only durable, but unsinkable as well. So for people whose livelihood and lives depend on their boat, Boston Whaler is the right choice because of our seaworthiness, dependability, and the inherent safety of a hull that won't sink even if severely damaged. Plain and simple, Boston Whaler boats are built to last.

In 1961, Fisher's demonstration of that unsinkability was captured by *Life* magazine in photos showing a Whaler® boat being sawed in half and Fisher then motoring away in the remaining half. True to Fisher's vision, Boston Whaler's world class team has consistently pushed the envelope, furthering advances in manufacturing, design, navigation, and propulsion technologies.

In 1996, Richard Fisher was posthumously inducted into the National Marine Manufacturer's Association (NMMA) hall of fame for accomplishments made in marine engineering and construction.



*In 1958, the legend is born as company founder Dick Fisher demonstrates a Boston Whaler's total unsinkability.*

## Table of Contents

### Introduction

Welcome Letter .....	Intro-1
History .....	Intro-2
Preface.....	Intro-5
Limited Warranty (US and Canada).....	Intro-6
Limited Warranty (Non-US or Canada) ...	Intro-11
CARB Warranty Statement .....	Intro-15
Privacy Statement .....	Intro-16
Owner's Manual .....	Intro-17
Contact Us.....	Intro-17
Boating Information .....	Intro-17

### Chapter 1 • Safety

Safety Labels .....	1-1
Safe Boating Means.....	1-2
Maintaining Control .....	1-3
Boarding.....	1-3
Impaired Operation .....	1-3
Operator's Responsibilities .....	1-4
Legally Mandated Equipment .....	1-4
Personal Flotation Devices (PFD's) .....	1-5
Fire Extinguisher.....	1-5
Sound Producing Devices .....	1-5
Visual Distress Signal .....	1-5
Carbon Monoxide (CO) .....	1-5
Lifesaving Equipment.....	1-7
Emergency Situations .....	1-7
Fire .....	1-8
Flooding, Swamping and Capsizing .....	1-9
Propulsion, Control or Steering Failure ....	1-10
Grounding .....	1-10
Distress Signals.....	1-10
Radio Communications .....	1-11
Weather .....	1-11
Swimming, Diving and Water Skiing.....	1-12
Engine Emergency Stop Switch .....	1-14
1st Mate Safety and Security System .....	1-15
Chart Course.....	1-15
Environmental Considerations .....	1-16
Homeland Security Restrictions .....	1-16
America's Waterway Watch .....	1-16
Safety Label Locations .....	1-16
Symbols Key .....	1-20

### Chapter 2 • General Information

Construction Standards.....	2-1
Hull Construction.....	2-1
Hull Identification Number.....	2-1
Vessel Servicing .....	2-1
Manufacturer's Certification.....	2-1
Certification Plates.....	2-2
Certification Design Category .....	2-4
Power Capacity .....	2-4
Specifications and Dimensions.....	2-5
Deck Occupancy.....	2-7
Recommended Occupant Locations.....	2-8
Navigation Lighting.....	2-9
Location of Thru-hull Fittings.....	2-10
Features .....	2-11
Deck.....	2-11
Lounge/ Console Area.....	2-12
Helm .....	2-13
Helm Switches.....	2-14
Console Storage .....	2-15
T-top Features (Option) .....	2-16
Hardtop Features (Option) .....	2-17
Deluxe Leaning Post (Option) .....	2-18
Competition Leaning Post (Option).....	2-19
Canvas (Option) .....	2-20
Storage .....	2-21

### Chapter 3 • Systems Overview and Operation

Boat Start-Up.....	3-1
Boat Shut-Down.....	3-2
Engine Trim .....	3-2
Active Trim .....	3-2
Throttle and Shift Control.....	3-3
Gauges.....	3-4
VesselView.....	3-4
VesselView Mobile (Option).....	3-4
Trim Tabs.....	3-5
Bilge Pump .....	3-6
Power Steering.....	3-7
Fuel System .....	3-8
Navigation Lighting.....	3-11
Freshwater System (Option).....	3-12
Raw Water Washdown (Option).....	3-12

# Introduction

Livewell .....	3-14	Stainless Steel.....	5-4
Head with Optional Deck Pumpout .....	3-16	Teak.....	5-5
Helm Seat with Livewell (Option).....	3-17	Seats.....	5-5
Bow Table (Option) .....	3-18	Aluminum .....	5-5
36V Trolling Motor Panel with 12V Outlet (Option).....	3-19	Standard Vinyl Cushions .....	5-6
Trolling Motor (Option) .....	3-20	Cool Technology Vinyl Cushions (Option)...	5-6
Shallow Water Anchor (Option) .....	3-21	Water Exposure.....	5-6
Jack Plate (Option).....	3-22	Instrumentation Cleaning.....	5-6
Reboarding Ladder .....	3-23	Canvas .....	5-6
Watersports Tow Point (Option).....	3-23	Acrylic Windscreen .....	5-7
All Activity Tower (Option) .....	3-24	Powder Coating Touch-up .....	5-8
Seating.....	3-25	Long-term Storage and Winterization.....	5-8
Seat Conversion to Fishing Platform.....	3-26	Engine.....	5-9
Pedestal Fishing Seats (Option) .....	3-28	Fuel System .....	5-9
Entertainment System (Option) .....	3-29	Electrical System .....	5-9
Anchoring .....	3-29	Batteries.....	5-10
Anchor Roller (Option).....	3-31	Drainage.....	5-10
Bow Shade (Option).....	3-32	Cover .....	5-10
Towing, Docking, Lifting and Trailering ....	3-32	Trailer Storage .....	5-10
Bow Tow Eye (Option) .....	3-33	Environment .....	5-10
Securing Boat to Trailer .....	3-35	Reinforcement Locations.....	5-11
Securing Trailer to Tow Vehicle .....	3-35		

## Chapter 4 • Electrical

DC Electrical System.....	4-1
Batteries.....	4-1
Battery Trays.....	4-1
Battery Switch.....	4-2
Automatic Charging Relays.....	4-3
Dockside Battery Charging (Option) .....	4-4
Fuse Block .....	4-5
Main DC Circuit Breaker .....	4-6
Transducer.....	4-7
Rigging Pulls.....	4-8
Wiring Identification Chart .....	4-9
Electrical Schematics .....	4-9

## Chapter 5 • Maintenance

Routine Care and Maintenance.....	5-1
Hull .....	5-1
Aquatic Invasive Species (AIS) .....	5-1
Waxing Gel Coat Surfaces .....	5-2
Hull Maintenance.....	5-2
Hull Blistering .....	5-2
Bottom Painting .....	5-3
Rubrails .....	5-4
Fiberglass and Non-Skid.....	5-4

# Introduction

---

## Preface

**READ AND RETAIN this manual. If the boat is sold, ensure all documentation is transferred to the new owner.**

Information in this publication is based on the latest product specifications available at the time of printing. Boston Whaler reserves the right to make changes at any time without prior notice. Boston Whaler is not responsible for specification changes to parts or accessories manufactured by other companies.

*NOTE: Equipment may vary depending on options selected.*

If needed in connection with selling your boat, service history or warranty records on vessels should be requested from the original selling dealer, the servicing dealer and/or the previous owner (where applicable). Information regarding open safety recalls is maintained by the United States Coast Guard, and can be obtained by visiting [uscgboating.org](http://uscgboating.org).

Brunswick Corporation registered trademarks: Mercury Marine, Mercury Racing, Optimax, Nautic-On, Skyhook, SmartCraft, Verado, Vantage, VesselView, VesselView Mobile.

Boston Whaler, Inc. registered trademarks: Boston Whaler, Boston Whaler with harpoon and hull logo, Conquest, Dauntless, Montauk, Outrage, Realm, Unibond, Whaler.

All other trademarks listed in this publication are the property of their respective owners.

**BOSTON WHALER® • A BRUNSWICK COMPANY**

© December 2020 Brunswick Corporation





## **BOSTON WHALER LIMITED MANUFACTURER WARRANTY (US AND CANADA)**

Boston Whaler, Inc. (“Boston Whaler”) provides the following Limited Manufacturer Warranty to the original retail owner of its 2023 model year Boats, if purchased from an authorized Boston Whaler Dealer and operated under normal, non-commercial use, subject to the remedies, exclusions, and limitations set out below.

1. **Ten-Year Structural Hull Limited Warranty:** Any Structural Hull Defect in material or workmanship which is reported within ten (10) years from the date of sale to the original retail owner will be repaired or replaced at Boston Whaler’s sole discretion. The “Hull” shall mean the single fiberglass molded shell and integral structural components. A Structural Hull Defect shall mean a substantial defect in the Boat’s Hull which causes the Boat to be unfit or unsafe for general use as a pleasure craft under normal operating conditions.

2. **Three-Year Limited Warranty on Components Manufactured or Installed By Boston Whaler:** (not applicable to 13 Super Sport or 16 Super Sport models): Boston Whaler will repair or replace, at its sole discretion, any components manufactured or installed by Boston Whaler that are defective in factory materials and/or workmanship, which are reported within three (3) years from the date of sale to the original retail owner, and are not addressed in the specific warranties listed in paragraphs 1 or 4 or set out in the Exclusions paragraph below.

3. **One-Year Limited Warranty on Accessory Components for the 13 Super Sport and 16 Super Sport Models:** Boston Whaler provides the following Limited Warranty to the original retail owner of any factory-authorized accessory for the 2023 model year 13 Super Sport and 16 Super Sport, if purchased from an authorized Boston Whaler Dealer, authorized Boston Whaler website or any Boston Whaler affiliate and utilized under normal, non-commercial use (“Accessory”), subject to the remedies, exclusions, and limitations set out below. Boston Whaler will repair or replace, at its sole discretion, any Accessory that is defective in material or workmanship, which is reported within one (1) year from the date of sale to the original retail owner. Boston Whaler is not responsible for any defect and/or damage to the Accessory and/or the Boat caused by improper installation, whether performed by the retail owner, dealer or any other third party.

4. **One-Year Limited Warranty on Upholstered Items, Canvas, Teak, and Powder Coating:** Boston Whaler will repair or replace, at its sole discretion, any upholstered items, canvas, teak, and powder coating manufactured or installed by Boston Whaler that are defective in factory materials and/or workmanship and are reported within one (1) year from the date of sale to the original retail owner.

5. **Limited Engine Warranty:** Retail owners will be entitled to the limited engine warranty as provided in the warranty manual from the engine manufacturer that was delivered to the retail owner with his or her Boston Whaler Boat.

### **EXCLUSIONS**

This Limited Manufacturer Warranty does not apply to any Boat which has been salvaged or declared a total loss or constructive total loss for any reason not covered in this limited warranty. This Warranty also does not apply to the following items:

- 1) Expenses for hauling out or transportation to and from the dealer or the Boston Whaler factory for warranty service.
- 2) Equipment or accessories which are not installed by Boston Whaler or which carry their own individual warranties, including but not limited to engines, engine components, batteries, propellers, controls, steering mechanisms, and electronics.

- 3) Damage, deterioration, discoloration or mold of cushions or cosmetic surface finishes, including scratches, gouges, chips, chalking, blistering, cracking, crazing, fading or oxidation of gel coat, stress lines, plated or painted metal and stainless steel finishes, plastics or acrylic materials, or anti-fouling bottom paint.
- 4) Windshield breakage and leakage.
- 5) Damage resulting from abuse, misuse, improper rigging and installation by an owner or any other person or entity that is not an authorized dealer, accidents, or overloading or powering in excess of the recommended maximum horsepower.
- 7) Failure of the owner to use, maintain, or store the Boat as specified in the Boston Whaler owner's manual; and any other failure to provide reasonable care and maintenance. Normal wear and tear maintenance items are excluded from warranty coverage including but not limited to filters, bulbs, batteries, bungees, wiper blades, anchor rope, trailer finishes, tires, brakes, bearings, and lights.
- 8) Any Boston Whaler Boat which has been altered or modified from Boston Whaler factory specifications, including penetration of the hull by anyone other than Boston Whaler factory personnel or Boston Whaler authorized dealer service personnel following factory specified procedures.
- 9) Damages resulting from use of improper trailer, improperly placed supporting bunks or slings, incorrect bunks placement, or improper boat lift or sling.
- 10) Damages due to failure to properly tow the Boat. For those Boats for which Boston Whaler offers a yacht tender package, damages due to towing when the package has not been installed.
- 11) Any Boston Whaler Boat used for commercial purposes, which includes, but is not limited to, any for-profit or other revenue-generating uses.
- 12) Any representation or implication relating to speed, range, fuel consumption or estimated performance characteristics.
- 13) Any failure or defect caused by an act of nature resulting in damage, cost, or expense.
- 14) Any failure or defect arising from a previous repair made by a non-authorized service provider.
- 15) Any item exceeding the expressed coverage limits specified in any Boston Whaler Limited Manufacturer Warranty.
- 16) Failure of the owner to use, maintain, or store an Accessory in reasonable fashion; and any other failure to provide reasonable care and maintenance.
- 17) Any accessory which has been altered or modified from Boston Whaler factory specifications.
- 18) Any accessory not purchased from an authorized Boston Whaler Dealer, authorized Boston Whaler website, or authorized Boston Whaler affiliate. For a list of Boston Whaler's affiliates, please refer to [www.brunswick.com](http://www.brunswick.com).
- 19) Any accessory used for commercial purposes, which includes but is not limited to, any for-profit or other revenue generating uses.
- 20) Any defect or repair requiring redesign of the Boat, except pursuant to the recall provisions of the United States Federal Boat Safety Act of 1971 or the recall laws of any other foreign jurisdiction.

#### **SOLE REMEDY**

THE REMEDY OF REPAIR OR REPLACEMENT OF PARTS OR MATERIALS THAT ARE FOUND TO BE DEFECTIVE IN FACTORY MATERIALS OR WORKMANSHIP COVERED BY THIS LIMITED MANUFACTURER WARRANTY SHALL CONSTITUTE THE OWNER'S SOLE AND EXCLUSIVE REMEDY AGAINST BOSTON WHALER FOR ANY CLAIMS WHATSOEVER OF ECONOMIC LOSS

RESULTING FROM PRODUCT FAILURE.

### **ENVIRONMENTAL POLICIES**

In keeping with environmental policies and practices, Boston Whaler reserves the right to utilize reconditioned, refurbished, repaired or remanufactured products or parts in the warranty repair or replacement process. Such products and parts will be comparable in function and performance to an original product or part and warranted for the remainder of the original warranty period. In no event shall any repair or replacement under this Limited Manufacturer Warranty exceed the fair market value of the product as of the date of the owner's claim. Acceptance of any product returned or any refund provided by Boston Whaler shall not be deemed an admission that the product is defective. Products that are replaced become the property of Boston Whaler.

### **OTHER LIMITATIONS**

EXCEPT AS SET FORTH HEREIN, THERE ARE NO OTHER WARRANTIES, EITHER EXPRESS OR IMPLIED, PROVIDED BY BOSTON WHALER ON THIS BOAT. ALL OTHER WARRANTIES, EXPRESS OR IMPLIED, INCLUDING IMPLIED WARRANTIES OF FITNESS AND MERCHANTABILITY, ARE EXPRESSLY EXCLUDED. BOSTON WHALER FURTHER DISCLAIMS ANY LIABILITY FOR ECONOMIC LOSS ARISING FROM CLAIMS OF PRODUCT FAILURE, NEGLIGENCE, DEFECTIVE DESIGN, MANUFACTURING DEFECT, FAILURE TO WARN AND/OR INSTRUCT, LACK OF SEAWORTHINESS, AND ANY OTHER THEORY OF LIABILITY NOT EXPRESSLY COVERED UNDER THE TERMS OF THIS LIMITED MANUFACTURER WARRANTY.

ANY IMPLIED WARRANTY OF MERCHANTABILITY OR FITNESS FOR A PARTICULAR PURPOSE IS DISCLAIMED. TO THE EXTENT THE IMPLIED WARRANTY CANNOT BE DISCLAIMED, IT IS LIMITED TO THE SHORTER OF ONE YEAR FROM THE DATE OF DELIVERY TO THE FIRST RETAIL OWNER OR THE DURATION OF THE RESPECTIVE EXPRESS LIMITED WARRANTIES STATED HEREIN. TO THE EXTENT ALLOWED BY LAW, NEITHER BOSTON WHALER, NOR THE SELLING DEALER, SHALL HAVE ANY RESPONSIBILITY FOR LOSS OF THE BOAT, LOSS OF TIME, INCONVENIENCE, COMMERCIAL LOSS OR CONSEQUENTIAL DAMAGES. SOME STATES DO NOT ALLOW LIMITATIONS ON HOW LONG AN IMPLIED WARRANTY LASTS, SO THE ABOVE LIMITATION MAY NOT BE APPLICABLE. SOME STATES DO NOT ALLOW THE EXCLUSION OR LIMITATION OF INCIDENTAL OR CONSEQUENTIAL DAMAGES, SO THE ABOVE LIMITATIONS OR EXCLUSIONS MAY NOT BE APPLICABLE. THIS WARRANTY GIVES THE OWNER SPECIFIC LEGAL RIGHTS, AND THE OWNER MAY ALSO HAVE OTHER RIGHTS WHICH VARY FROM STATE TO STATE OR COUNTRY TO COUNTRY.

### **STATUTE OF LIMITATIONS**

Any action for rescission or revocation against Boston Whaler shall be barred unless it is commenced within one (1) year from the date of accrual of such cause of action. This provision does not grant any consumer a right of rescission or revocation against Boston Whaler, where such right does not otherwise exist under applicable law. Some states may not allow the applicable statute of limitations for rescission or revocation to be reduced, so this provision may not apply to each retail owner.

### **OWNER'S OBLIGATIONS**

To initiate a warranty claim, it is the responsibility of the owner to contact an authorized Boston Whaler dealer immediately after discovery of any defect, describe the nature of the problem, and provide a hull serial number, date of purchase, and name of selling dealer. The authorized dealer will notify Boston Whaler, who is solely responsible for determining and authorizing in writing the remedial action(s) to be performed at either an authorized Boston Whaler dealership chosen by Boston Whaler or at the Boston Whaler factory.

The owner should notify Boston Whaler of any Boat being repaired by an authorized Boston Whaler dealer which has been at the dealership for fifteen (15) days, or of any claimed defect which was not corrected after one repair attempt. The owner must provide Boston Whaler with a reasonable opportunity to repair, and reasonable access to the Boston Whaler Boat for warranty service and the owner shall pay for all related transportation charges and/or travel time. If the owner cannot deliver the product to such a dealer, written notice must be given to Boston Whaler. Boston Whaler will then arrange for the inspection and any covered repair and the owner shall pay for all related transportation charges and/or travel time. Our privacy policies are available at [www.bostonwhaler.com](http://www.bostonwhaler.com).

#### **ASSIGNMENT OF COMPONENT WARRANTIES**

Except as expressly set out herein, all warranties provided by the manufacturers and distributors of components, equipment, and parts on the Boat (collectively “Component Manufacturers”) are hereby assigned to the owner to the extent permitted by the Component Manufacturers, as the owner’s sole and exclusive remedy with respect to such items.

#### **REGISTRATION & WARRANTY TRANSFER POLICY**

The limited warranty coverage is activated by the authorized selling dealer registering the sale of a new Boat with Boston Whaler.

The Ten-Year, Three-Year, and One-Year limited warranties are transferable to a subsequent owner, except the one-year Accessory warranty which is not transferrable and this Limited Manufacturer Warranty will not transfer to any new owner of a Boat which has been salvaged and resold, or resold after a declaration of a total loss or a constructive total loss, i.e., the cost of repair exceeds the value of the Boat. The new owner must fill out and submit the online Boston Whaler warranty transfer form, accessible from [www.bostonwhaler.com](http://www.bostonwhaler.com). A copy of the bill of sale will be required to submit with the form. The warranty transfer must be completed within 30 days of purchase. Notwithstanding anything in this Limited Manufacturer Warranty to the contrary, Boston Whaler reserves the right to reject any warranty transfer request for a Boston Whaler Boat that has been damaged, neglected, or otherwise previously excluded from warranty.

#### **MODIFICATIONS & SEVERABILITY**

The terms and conditions contained herein, as well as those of any documents prepared in conjunction with the sale of this vessel may not be modified, altered or waived by any action, inaction, or representations, whether oral or in writing, except upon the expressed, written authority of a management level employee of Boston Whaler. The invalidity or unenforceability of any one or more of the provisions herein shall not affect the validity and enforceability of the other provisions.

#### **GOVERNING LAW AND VENUE**

This Warranty shall be interpreted and construed according to and governed by the laws of the State of Tennessee, without regard to conflict of law principles. Venue for any and all disputes arising out of or related to this Warranty, including without limitation the interpretation, performance or breach of this Warranty, shall be solely and exclusively before the United States District Court for the Eastern District of the State of Tennessee. The parties consent to the in personam jurisdiction of said court for the purposes of any such litigation and waive, fully and completely, any right to dismiss and/or transfer any action pursuant to 28 U.S.C. Section 1404 or 1406 (or any successor statutes) or the doctrine of forum non conveniens. If the United States District Court does not have subject matter jurisdiction of said matter, then such matter shall be litigated solely and exclusively before the appropriate state court of competent jurisdiction located in Knox County, Tennessee, and the parties consent to the personal jurisdiction of such court for the purpose of such litigation.



## **SAFETY**

It is your responsibility (as well as the responsibility of any other operator of this Boat) to be familiar with and observe all local, state and federal laws, rules and regulations regarding boating, navigation and boating safety. You and any other operator of this Boat should take a course in boating and boating safety before operation of this Boat and should be completely familiar with all systems regarding safe operation of this Boat. Personal flotation devices should be worn by each passenger in accordance with U.S. Coast Guard standards and state and federal law.

**World Headquarters**  
**100 Whaler Way, Edgewater, FL 32141**  
**(386) 428-0057**  
**[www.bostonwhaler.com](http://www.bostonwhaler.com)**

## **BOSTON WHALER LIMITED MANUFACTURER WARRANTY (Outside the U.S. or Canada)**

Boston Whaler, Inc. (“Boston Whaler”) provides the following Limited Manufacturer Warranty to the original retail owner of its 2023 model year Boats, that if purchased from an authorized Boston Whaler dealer and operated under normal, non-commercial use, the authorized dealer will repair or replace, at its sole discretion, any defect in material or workmanship in the Boston Whaler Boat that is reported within the applicable Limited Manufacturer Warranty periods and within the scope as set out below.

Mandatory warranty rights, including a consumer’s mandatory statutory rights, by law are not affected by this Limited Manufacturer Warranty and in particular not limited or excluded. These mandatory legal rights exist regardless of whether a warranty claim occurs or rights are asserted under this Limited Manufacturer Warranty.

### **SCOPE**

This Limited Manufacturer Warranty applies only to Boston Whaler Boats purchased outside of the US and Canada, including the territory of the European Union and Australia, and to recreational use customers only (not commercial users). Commercial use, which voids the Limited Manufacturer Warranty, is defined as any use of the product which generates income, even if the product is only occasionally used for such purposes.

Routine maintenance outlined in the Operation and Maintenance Manual must be timely performed in order to maintain Limited Manufacturer Warranty coverage. This Limited Manufacturer Warranty applies to the following items:

1. **Ten-Year Structural Hull Limited Warranty:** Any Structural Hull Defect in material or workmanship which is reported within ten (10) years from the date of sale to the original retail owner will be repaired or replaced at Boston Whaler’s sole discretion. The “Hull” shall mean the single fiberglass molded shell and integral structural components. A Structural Hull Defect shall mean a substantial defect in the Boat’s Hull which causes the Boat to be unfit or unsafe for general use as a pleasure craft under normal operating conditions
2. **Three-Year Limited Warranty on Components Manufactured or Installed By Boston Whaler (not applicable to 13 Super Sport or 16 Super Sport models):** Boston Whaler will repair or replace, at its sole discretion, any components manufactured or installed by Boston Whaler that are defective in factory materials and/or workmanship, which are reported within three (3) years from the date of sale to the original retail owner, and are not addressed in the specific warranties listed in paragraphs 1 or 4 or set out in the Exclusions paragraph below.
3. **One-Year Limited Warranty on Accessory Components for the 13 Super Sport and 16 Super Sport Models:** Boston Whaler provides the following Limited Warranty to the original retail owner of any factory-authorized accessory for the 2023 model year 13 Super Sport and 16 Super Sport, if purchased from an authorized Boston Whaler Dealer, authorized Boston Whaler website or any Boston Whaler affiliate and utilized under normal, non-commercial use (“Accessory”), subject to the remedies, exclusions, and limitations set out below. Boston Whaler will repair or replace, at its sole discretion, any Accessory that is defective in material or workmanship, which is reported within one (1) year from the date of sale to the original retail owner. Boston Whaler is not responsible for any defect and/or damage to the Accessory and/or the Boat caused by improper installation, whether performed by the retail consumer, dealer or any other third party.
4. **One-Year Limited Warranty on Upholstered Items, Canvas, Teak, and Powder Coating:** Boston Whaler will repair or replace, at its sole discretion, any upholstered items, canvas, teak, and powder coating manufactured or installed by Boston Whaler that are defective in factory materials and/or workmanship and are reported within one (1) year from the date of sale to the original retail owner.

5. Limited Engine Warranty: Retail owners will be entitled to the limited engine warranty as provided in the warranty manual from the engine manufacturer that was delivered to the original retail owner with his or her Boston Whaler Boat.

## EXCLUSIONS

This Limited Manufacturer Warranty does not apply to any Boat which has been salvaged or declared a total loss or constructive total loss for any reason not covered in this limited warranty. This warranty also does not apply to the following items:

- 1) Expenses for hauling out, transportation to and from the dealer or the Boston Whaler factory for warranty service.
- 2) Equipment or accessories which are not installed by Boston Whaler or which carry their own individual warranties, including but not limited to engines, engine components, batteries, propellers, controls, steering mechanisms, and electronics.
- 3) Damage, deterioration, discoloration or mold of cushions or cosmetic surface finishes, including scratches, gouges, chips, chalking, blistering, cracking, crazing, fading or oxidation of gel coat, stress lines, plated or painted metal and stainless steel finishes, plastics or acrylic materials, or anti-fouling bottom paint.
- 4) Windshield breakage and leakage.
- 5) Any Boston Whaler Boat initially sold at retail by a party other than an authorized Boston Whaler dealer.
- 6) Damage resulting from abuse, misuse, improper rigging and installation by an owner or any other person or entity not being an authorized dealer, accidents, overloading or powering in excess of the recommended maximum horsepower.
- 7) Failure of the owner to use, maintain, or store the Boat as specified in the Boston Whaler owner's manual; and any other failure to provide reasonable care and maintenance. Normal wear and tear maintenance items are excluded from warranty coverage including but not limited to filters, bulbs, batteries, bungees, wiper blades, anchor rope, trailer finishes, tires, brakes, bearings and lights.
- 8) Damages due to failure to properly tow the Boat. For those Boats for which Boston Whaler offers a yacht tender package, damage due to towing when the package has not been installed.
- 9) Any Boston Whaler Boat which has been altered or modified from Boston Whaler factory specifications, including penetration of the hull by anyone other than Boston Whaler factory personnel or Boston Whaler authorized dealer service personnel following factory specified procedures.
- 10) Damage resulting from use of improper trailer, improperly placed supporting bunks or slings, incorrect bunks placement and improper Boat lift or sling.
- 11) Any Boston Whaler Boat used for commercial purposes, which includes, but is not limited to, any for-profit or other revenue-generating uses.
- 12) Any representation or implication relating to speed, range, fuel consumption or estimated performance characteristics.
- 13) Any failure or defect caused by an act of nature resulting in damage, cost, or expense;
- 14) Any failure or defect arising from a previous repair made by a non-authorized service provider.
- 15) Any item exceeding the expressed coverage limits specified in any Boston Whaler Limited Manufacturer Warranty.
- 16) Failure of the owner to use, maintain, or store an Accessory in reasonable fashion; and any other failure

to provide reasonable care and maintenance.

17) Any Accessory which has been altered or modified from Boston Whaler factory specifications.

18) Any Accessory not purchased from an authorized Boston Whaler Dealer, authorized Boston Whaler website, or authorized Boston Whaler affiliate. For a list of Boston Whaler's affiliates, please refer to [www.brunswick.com](http://www.brunswick.com).

19) Any Accessory used for commercial purposes, which includes but is not limited to, any for-profit or other revenue generating uses.

20) Any defect or repair requiring redesign of the Boat, except pursuant to the recall provisions of the United States Federal Boat Safety Act of 1971 or the recall laws of any other foreign jurisdiction.

#### **ENVIRONMENTAL POLICIES**

In keeping with environmental policies and practices, Boston Whaler reserves the right to utilize reconditioned, refurbished, repaired or remanufactured products or parts in the warranty repair or replacement process. Such products and parts will be comparable in function and performance to an original product or part and warranted for the remainder of the original warranty period.

#### **ACCESS FOR SERVICE**

The owner must provide Boston Whaler with a reasonable opportunity to repair, and reasonable access to the Boston Whaler Boat for warranty service. Warranty claims shall be made by delivering the Boston Whaler Boat for inspection to a Boston Whaler dealer authorized to service the product. If the owner cannot deliver the product to such a dealer, written notice must be given to Boston Whaler. Boston Whaler will then arrange for the inspection and any covered repair and the owner shall pay for all related transportation charges and/or travel time.

#### **STATUTE OF LIMITATIONS**

Without prejudice to your mandatory statutory rights, any action for rescission or revocation against Boston Whaler shall be barred unless it is commenced within one (1) year from the date of accrual of such cause of action, unless a longer period is prescribed by local law. This section shall not apply to Boston Whaler Boats purchased in Australia.

#### **ASSIGNMENT OF COMPONENT WARRANTIES**

Except as expressly set out herein, all warranties provided by the manufacturers and distributors of components, equipment, and parts on the Boat (collectively "Component Manufacturers") are hereby assigned to the owner to the extent permitted by the Component Manufacturers, as the owner's sole and exclusive remedy with respect to such items.

#### **OWNER'S OBLIGATIONS**

To initiate a warranty claim, it is the responsibility of the owner to contact an authorized Boston Whaler dealer immediately after discovery of any defect, describe the nature of the problem, and provide a hull serial number, date of purchase, and name of selling dealer. The authorized dealer will notify Boston Whaler, who is solely responsible for determining and authorizing in writing the remedial action(s) to be performed at either an authorized Boston Whaler dealership chosen by Boston Whaler or at the Boston Whaler factory. The owner should notify Boston Whaler of any Boat being repaired by an authorized Boston Whaler dealer which has been at the dealership for fifteen (15) days, or of any claimed defect which was not corrected after one repair attempt. Our privacy policies are available at [www.bostonwhaler.com](http://www.bostonwhaler.com).



## **REGISTRATION & WARRANTY TRANSFER POLICY**

The limited warranty coverage is activated by the authorized selling dealer registering the sale of a new Boat with Boston Whaler.

The Ten-year, Three-year, and One-year Limited Warranties are transferable to a subsequent owner, except the One-year Accessory Warranty which is not transferrable, and this Limited Manufacturer Warranty will not transfer to any new owner of a Boat which has been salvaged and resold, or resold after a declaration of a total loss or a constructive total loss, i.e., the cost of repair exceeds the value of the Boat. The new owner must fill out and submit the online Boston Whaler warranty transfer form, accessible from [www.bostonwhaler.com](http://www.bostonwhaler.com). A copy of the bill of sale will be required to submit with the form. The warranty transfer must be completed within 30 days of purchase. Notwithstanding anything in this Limited Manufacturer Warranty to the contrary, Boston Whaler reserves the right to reject any warranty transfer request for a Boston Whaler Boat that has been damaged, neglected, or otherwise previously excluded from warranty.

## **MODIFICATIONS & SEVERABILITY**

The terms and conditions contained herein, as well as those of any documents prepared in conjunction with the sale of this vessel may not be modified, altered or waived by any action, inaction, or representations, whether oral or in writing, except upon the expressed, written authority of a management level employee of Boston Whaler. The invalidity or unenforceability of any one or more of the provisions herein shall not affect the validity and enforceability of the other provisions.

## **SAFETY**

It is your responsibility (as well as the responsibility of any other operator of this Boat) to be familiar with and observe all local, state and federal laws, rules and regulations regarding Boating, navigation and Boating safety. You and any other operator of this Boat should take a course in Boating and Boating safety before operation of this Boat and should be completely familiar with all systems regarding safe operation of this Boat. Personal flotation devices should be worn by each passenger in accordance with applicable standards and state and federal law.

## **THE FOLLOWING SECTION IS APPLICABLE TO AUSTRALIAN CONSUMERS ONLY**

Boston Whaler Boats come with guarantees that cannot be excluded under the Australian Consumer Law. Retail owners are entitled to a replacement or refund for a major failure and compensation for any other reasonably foreseeable loss or damage. Retail owners are also entitled to have the goods repaired or replaced if the goods fail to be of acceptable quality and the failure does not amount to a major failure.

This Limited Manufacturer Warranty does not cover any expenses that retail owners may incur claiming the warranty.

The benefits to retail owners given by this Limited Manufacturer Warranty are in addition to other rights and remedies of the consumer under a law in relation to the goods or services to which the Limited Manufacturer Warranty relates.

**World Headquarters**  
**100 Whaler Way, Edgewater, FL 32141**  
**011 1 (386) 428-0057**  
**[www.bostonwhaler.com](http://www.bostonwhaler.com)**

**CALIFORNIA EVAPORATIVE EMISSIONS  
CONTROL SYSTEM WARRANTY STATEMENT**

**YOUR WARRANTY RIGHTS AND OBLIGATIONS**

The California Air Resources Board and Boston Whaler, Inc. are pleased to explain the evaporative emission control system's warranty on your 2023 MY spark-ignition marine watercraft (SIMW). In California, new spark-ignition marine watercraft must be designed, built, and equipped to meet the State's stringent anti-smog standards. Boston Whaler, Inc. must warrant the evaporative emission control system on your spark ignition marine watercraft for the period listed below provided there has been no abuse, neglect or improper maintenance of your spark-ignition marine watercraft.

Your evaporative emission control system may include parts such as: carburetors, fuel tanks, fuel lines, fuel caps, valves, canisters, filters, vapor hoses, clamps, connectors, and other associated components.

**MANUFACTURER'S WARRANTY COVERAGE:**

This evaporative emission control system is warranted for three years. If any evaporative emission-related part on your spark-ignition marine watercraft is defective, the part will be repaired or replaced by Boston Whaler, Inc.

**OWNER'S WARRANTY RESPONSIBILITIES:**

- As the spark ignition marine watercraft owner, you are responsible for performance of the required maintenance listed in your owner's manual. Boston Whaler, Inc. recommends that you retain all receipts covering maintenance on your SIMW, but Boston Whaler, Inc. cannot deny warranty solely for the lack of receipts.
- As the SIMW owner, you should however be aware that the Boston Whaler, Inc. may deny you warranty coverage if your spark-ignition marine watercraft or a part has failed due to abuse, neglect, or improper maintenance or unapproved modifications.
- You are responsible for presenting your spark-ignition marine watercraft to a Boston Whaler, Inc. distribution center or service center as soon as the problem exists. The warranty repairs should be completed in a reasonable amount of time, not to exceed 30 days. If you have a question regarding your warranty coverage, you should contact Boston Whaler, Inc. at 877-294-5645.

**SIMW EVAPORATIVE EMISSIONS WARRANTY PARTS:**

Fuel tank	Grade valves
Fuel feed hoses	Fuel fill deck plate w/cap and pressure relief valve
Fuel line fittings	Hose clamps on fuel system components
Fuel demand valves	Fuel level vent valve

All other parts not listed that may affect the evaporative emissions control system.

# Introduction

---

## PRIVACY STATEMENT

Thank you for purchasing a boat or requesting information from Boston Whaler. This Privacy Statement is to inform you how we collect, use, disclose, and safeguard the personal information you provide to us through your purchases, requests for brochures, product registration cards, promotions, surveys, call centers, or other customer contacts. To see our full Privacy Policy and any updates, please visit [www.bostonwhaler.com](http://www.bostonwhaler.com) and select the Privacy Statement link. "Personal information" may include your name, age, mailing address, residential phone number, or e-mail address. It may also include income ranges, marital status, product or lifestyle preferences, and information concerning dealer service.

**How we collect personal information:** Our authorized dealer provided Boston Whaler or our company in the European Union with personal information collected at the time of your boat order/purchase with other product registration data and will continue to provide warranty and servicing information on your boat. We will send you customer satisfaction surveys which you may elect to return to provide us with information on your boat purchase and your servicing needs. Your personal information may be gathered by or shared with Boston Whaler's marketing providers and affiliated companies, who have comparable levels of privacy protection, for the purposes described in this statement. Boston Whaler, your dealer, and our marketing providers collect personal information when your request information about our companies and from surveys, promotions, contests, correspondence, your e-mails, telephone inquiries, web forms, and other communications. **How We Use and Disclose Personal Information:** Unless you advise us otherwise, Boston Whaler, our authorized dealers, affiliated companies, and our marketing providers may generally collect, use, disclose, hold, and file your personal information for the following purposes: (1) Providing goods, brochures, information, incentives, and/or services to you or on your behalf; (2) Fulfilling the terms of our limited warranty or other service obligation; (3) Facilitating recalls or service campaigns if necessary; (4) Reviewing goods and/or services provided to you in product, services, and marketing analyses; (5) Ensuring your satisfaction through surveys or other contacts; (6) Administration, billing, accounting, and collections; and protecting against fraud and error; and (7) Investigating a breach or a contravention of a law, complying with a subpoena, warrant, court order, or as required or otherwise permitted by law. Boston whaler will not sell your personal information or subject you to telemarketing or unsolicited e-mail.

**Safeguards:** We use security safeguards appropriate to the sensitivity of personal information to protect it from loss or theft, as well as prohibiting unauthorized access, disclosure, copying, use or modification of your personal information. These safeguards include restricted access to offices and equipment, security clearances, the use of passwords and/or encryption, publishing our privacy policy to appropriate personnel with instructions to act in accordance with its principles, and contractual provisions with our marketing agents and authorized dealers to follow the principles of our privacy policy.

**Access and correction to your personal information:** Subject to the exceptions provided by applicable law, we will provide, upon written request, your specific personal information collected in a form which is generally understandable. Your Personal Information is held by us and for us by our marketing agency, Rollick Company, who has contractually agreed to protect your information according to our privacy policies at the following addresses: Boston Whaler Inc., 100 Whaler Way, Edgewater, FL 32141. Please direct corrections, withdrawal of consent for specific purpose, complaints or other inquiries regarding personal information to: Rollick Company, 1078 Headquarters Park Drive, Fenton, MO, 63026; phone: (636) 343-9988, fax: (636) 326-3282. You can withdraw consent for us to use your personal information at any time or provide corrections upon providing to us a 30-day notice, unless withdrawing consent would impede the performance of legal obligations. We are required by law to provide you with information for product recall and other product safety relates purposes. The withdrawal of your consent may also adversely affect our ability to provide products and services to you and to maintain our relationship. Please note, notifying us will not result in withdrawing consent from your dealer, who should be contacted separately.

**Obtaining consent:** If any supplementary disclosure is required, we will obtain your consent for disclosure to other persons or organizations and for other purposes than stated herein, unless otherwise permitted by law.

Thank you for your business. We hope you have many years of wonderful boating experiences!

# Introduction

## Owner's Packet

The owner's packet is a large, zippered bag that contains all the manuals and instructional information for non-Boston Whaler equipment and systems on your boat. Read and retain this information.

## Owner's Manual

The contents of this manual:

• Provides basic boating safety information	• Details the boat's features and equipment
• Outlines the fundamentals of boat use	• Contains maintenance information

You must learn to operate this boat as well as read, understand and use this manual. This manual does not give you a course in boating safety or how to navigate, anchor or dock your boat. Operating a power boat safely requires more skills, knowledge, and awareness than is necessary for a motor vehicle.

## Your Responsibilities

For the safety of you and your passengers, other boaters as well as people in the water, you must:

• Take a boating safety course	• Understand and follow the <i>rules of the road</i>
• Get instruction in proper boat handling	• Learn how to navigate

## Contact Us

### Boston Whaler, Inc.

877-294-5645

[www.bostonwhaler.com](http://www.bostonwhaler.com)

## Warranties

In addition to the Boston Whaler® Limited Warranty, each component and/or system on your boat has its own warranty that can be found with the specific information and manual for that component. These are included with your owner's information packet. Please locate, read, and retain the individual warranties.

## Boating Information\*

A comprehensive background in boating can be found in the book, *Chapman Piloting: Seamanship & Small Boat Handling*, by Elbert Maloney. For boating courses in North America, contact one of the following organizations:

Organization	Website	Phone
BoatUS Foundation	<a href="http://boatus.org">boatus.org</a>	800-336-2628
U.S. Coast Guard	<a href="http://uscgboating.org">uscgboating.org</a>	—
U.S. Coast Guard Auxiliary	<a href="http://cgaux.org">cgaux.org</a>	877-875-6296
US Power Squadron	<a href="http://usps.org">usps.org</a>	888 367-8777
Canadian Coast Guard	<a href="http://cgc-gcc.gc.ca">cgc-gcc.gc.ca</a>	800-267-6687
Canadian Power and Sail Squadrons	<a href="http://cps-ecp.ca">cps-ecp.ca</a>	888-277-2628
Red Cross	<a href="http://redcross.org">redcross.org</a>	800-733-2767

State boating offices

Yacht clubs

\*Outside of North America, contact your dealer or your governmental boating agency for assistance.

---

---

THIS PAGE INTENTIONALLY LEFT BLANK

## Safety Labels

The most important aspect of boating is safety. Although every effort is made to address the numerous issues regarding the safe use of this vessel, it is strongly recommended that you avail yourself of the training and knowledge available through boating safety courses.

Mounted at key locations throughout this vessel are safety labels which advise the operator of imperative safety precautions to follow when operating and/or servicing equipment. Label categories are broken down by color and type.

### **DANGER**

Denotes an immediate hazard exists that **WILL** result in severe personal injury or death.

### **WARNING**

Denotes hazards or unsafe practices that **MAY** result in severe personal injury or death.

### **CAUTION**

Denotes hazards or unsafe practices that **COULD** result in minor personal injury, product or property damage.

### **NOTICE**

Denotes information that is important to know prior to operation and/or maintenance, but is not hazard related.

Below are black and white examples of safety labels which appear throughout this manual and must be observed when operating or servicing your boat. Learn to recognize the label category and understand the explanations before reading this manual.

### **DANGER**

Denotes an immediate hazard exists that **WILL** result in severe personal injury or death.

### **WARNING**

Denotes hazards or unsafe practices that **MAY** result in severe personal injury or death.

### **CAUTION**

Denotes hazards or unsafe practices that **COULD** result in minor personal injury, product or property damage.

### **NOTICE**

Denotes information that is important to know prior to operation and/or maintenance, but is not hazard related.

### **ATTENTION**

Denotes information found in the owner's manual to call attention to the safe operation or certain features of this vessel.

## Safe Boating Means

- Knowing the limitations of this vessel.
- Following navigational rules (rules of the road).
- Be aware of people and objects in the water.
- Not boating in water or weather conditions that are beyond the boat's and operator's capability.
- Never operating the boat while under the influence of drugs or alcohol.
- Being aware of passenger safety at all times.
- Reducing speed when there is limited visibility, rough water, boats or structures.

### NOTICE

**As a boat owner or operator, you are responsible for the safety of you, your passengers, and other boaters.**

Boating in beautiful weather and calm water conditions can be a wonderful experience. But boating requires considerably greater skills than operating a land vehicle. Taking a boating course is the best way to prepare for a safe and enjoyable experience on the water.

- Take a USCG, U.S. Power Squadron or equivalent boating safety course. Call the BoatUS Foundation at 800-336-2628 for information on available courses, or go to: [www.boatus.org](http://www.boatus.org)
- Get hands on training on how to operate this vessel properly.

## Safe Boating Checklist

### Before Departure

- Check weather forecast
- Check required documents are on board
- Check navigation charts are on board
- Check safety equipment is on board
- Ensure passengers and crew have received safety instructions on procedures, location, and use of safety equipment.
- Check drain plugs are installed
- Check bilge pumps are working and clean
- Check blower is working
- Check navigation lights are working
- Check horn is working
- Check fuel system has no leaks or fumes
- Check fuel filter is tight and clean
- Check power steering fluid is full (if applicable)
- Check steering system is working smoothly
- Battery connections and fluid levels (if applicable)
- File float plan with friend or relative

### Trailing (if applicable)

- Check boat position is secure on trailer
- Check tiedowns are tight
- Check winch is locked
- Check trailer hitch is connected
- Check engine clearance in trailering position
- Check safety chains are attached
- Test lights, brake lights, and turn signals
- Adjust mirrors for trailering

### After Return

- Dry and stow PFDs and other safety gear
- Fill fuel tanks (allow for expansion) to prevent condensation
- Check fuel system for leaks
- Check bilge pump is operating properly
- Check bilge is clean and leak free
- Check in with float plan notification person

## General Considerations

- Know how this vessel handles under different conditions. Recognize your limitations and the boat's limitations. Modify speed in keeping with weather, sea, and traffic conditions.
- Instruct passengers on location and use of safety equipment and procedures.
- Instruct passengers on the fundamentals of operating this vessel in case you are unable to do so.
- You are responsible for passenger's actions. If they place themselves or the boat in danger, immediately correct them.
- Remember the *Rule of Thirds*: Use one third of the fuel for the trip outbound, one third for the return trip, and keep one third for reserve.

## Maintaining Control

High performance boats require intimate knowledge of each vessel's handling characteristics for safe, high speed operation.

- Learn the effects of trim, steering and throttle changes at gradually increasing levels of speed.
- Approach full throttle while adjusting trim for safe handling of the vessel.

On the water there are no marked traffic lanes, no traffic signs or lights, and boats have no turn signals. The boat operator must keep her or his attention focused not only on what's ahead but what's on the left, right, and behind the boat.

The operator must always be alert to approaching boats (from the rear, right and left sides, as well as those ahead). There can be a variety of navigational hazards in the water including partially submerged debris, rocks, sand bars or dangerous currents, to name a few.

Your passengers are relying on you to operate and maneuver the boat safely so that they are not in danger of going overboard. If you turn too quickly or increase or decrease speed abruptly, your passengers are at risk of being thrown overboard or thrown about the boat.

When visibility becomes impaired because of

weather or time of day, use navigational lights to ensure other boats can see you. In addition, if high bow angle causes reduced visibility, slow down to allow sufficient time to react if an emergency occurs.

## Boarding

- Board only one person at a time.
- Never jump into boat; step or climb.
- Load gear after aboard. Carrying gear while boarding can cause you to lose balance.
- Distribute weight evenly.
- Instruct passengers where to sit during on plane operation to reduce the possibility of falling overboard during high speed maneuvers.
- If gear is not immediately needed, stow it in secure areas.
- Safety gear must be immediately accessible at all times.

## Impaired Operation

### **WARNING**

**Control Hazard - Federal laws prohibit operating a boat while under the influence of alcohol or drugs. These laws are vigorously enforced.**

The detrimental effects of alcohol and drugs are increased by wind, waves and sun, and will decrease your response time and ability to react in critical situations. Give special attention to the effects of alcohol and drugs while boating. No other single factor causes as many marine accidents and deaths. Death or serious injury and damage to personal and private property can result from being impaired while operating a boat.



## Operator Responsibilities

Your degree of enjoyment on the water depends on you, your equipment and other people who, like yourself, boat responsibly. As a boat operator you should:

- Make sure that all occupants always wear a w Coast Guard-approved life jacket while on the water.
- All boat operators should complete a boating safety course (a requirement in many states).
- All boat operators must become familiar with the proper operation of all vessel features prior to departure.
- Always maintain a safe speed.
- Be aware of conditions in every direction always when underway.
- Mind your wake. It can capsize a small boat or damage moored boats or other property. You are responsible for damage caused by your wake.
- Reduce speed and post a lookout to identify hazards when:
  - Visibility is impaired
  - In rough water
  - In congested waterways
- Display navigation lights between sunset and sunrise and during periods of restricted visibility, such as rain, fog, haze, etc.

### **WARNING**

**A qualified operator must be in control of the boat at all times. Do not operate the boat while under the influence of alcohol or drugs. Never operate this vessel at speeds which exceed the operator's ability to react if an emergency develops. At night, turn on the appropriate navigation lights and cruise at a reduced speed that allows you plenty of time to avoid dangerous situations.**

### **WARNING**

#### **STABILITY HAZARD**

- **Load boat properly. The manufacturer's load rating is the maximum weight allowed under normal conditions. Adjust downward if weather, water or other conditions are adverse.**
- **Allow passengers to ride only in areas that do not pose a hazard to themselves or the boat.**
- **Do not allow passengers to ride on the bow of a closed-bow boat.**
- **Do not allow several passengers to ride in the bow of a small open-bow boat, causing the boat to plow in the water.**
- **Do not allow passengers to ride on the stern cushion or gunwales.**
- **Do not overload the stern.**
- **Observe manufacturer's recommended on-plane seating locations.**
- **Passengers should remain seated while boat is moving.**

**Personal injury hazard - Stay alert. Use of drugs, alcohol, or other substances which impair judgement poses a serious threat to yourself and others. The boat operator is responsible for the behavior of passengers.**

**Drowning hazard - Boats must carry one wearable personal flotation devices (PFDs) for every passenger on board. Boats must have at least one throwable life preserver.**

**Slipping hazard - Wet decks are slippery. Wear proper footwear and use extreme caution on wet surfaces.**

## Legally Mandated Equipment

Consult your national boating law enforcement agency. The following equipment is the minimum required by the United States Coast Guard (USCG) for boats under 26 feet (7.9 meters).

## Personal Flotation Devices (PFD's)

One USCG approved Type I, II or III is mandatory for each person aboard. One throwable Type IV device is also required to be onboard and located so that it is immediately available.

A Type V device is acceptable (see *PFD Classifications*, later in this chapter) if worn for approved use. Always wear a PFD when boating.

### **WARNING**

**There is rarely time to reach stowed life jackets in time of emergency. Boaters should always wear a properly fitting, approved life jacket when on the water. Children and non-swimmers must wear PFDs at all times when aboard.**

### **NOTICE**

**Depending on the state or country of operation, the operator of a vessel may be fined for failure to comply with local or national rules regarding PFD usage.**

## Fire Extinguisher

If there is no fixed fire extinguishing system installed, one size 5-B portable fire extinguisher must be on board. If a fixed system is installed no portable fire extinguisher is required. The American Boat & Yacht Council (ABYC) recommends two 5-B type ABC portable fire extinguishers be on board and located within easy reach of helm and galley or passenger area.

## Sound Producing Devices

Ensure a sound producing device such as a horn or whistle is on board. Navigation rules require that a sound made by an audible device be capable of a four second blast, and be audible for 1/2 mile (.80 km).

## Visual Distress Signals

If you operate this vessel in coastal waters or on the Great Lakes, you must have visual distress signals for day and night use on board. At least three day/night combination pyrotechnic devices must be carried, readily accessible, in serviceable condition, and not be expired. Non-pyrotechnic substitutes include one

orange flag for day-use and one electric S-O-S signal light for night-use. Store all pyrotechnic signals in a well marked, waterproof container.

## Additional Required Equipment

This vessel comes equipped with other mandated equipment such as navigation lights, and certified marine sanitation device (Option).

## Additional Safety Equipment

In addition to the legally mandated equipment, the following items are necessary for safe boating, especially if this vessel will be out of sight of land.

- First Aid kit
- GPS
- Marine VHF radio
- Moisture repellent
- Mooring lines
- Fenders
- Moisture repellent
- Waterproof flashlights
- High power spotlight
- Spare propeller
- Tool kit
- Anchor
- Compass
- Manual bilge pump
- Spare keys
- EPIRB emergency positioning indicating radio beacon
- Boat hook
- Extra batteries
- Instruction manuals
- Lubricating oil
- Screwdrivers (Phillips and flat)
- Pliers (regular, Vise-grip, tongue and groove)
- Wrenches (box, open end, Allen and adjustable)
- Socket set (metric and U.S.)
- Electrical tape and duct tape
- Hammer
- Spare parts kit (spark plugs, fuses, etc.)

## Carbon Monoxide (CO)

Carbon monoxide (CO) is an odorless, colorless, and extremely toxic gas produced by engines, heaters, stoves or generators. When inhaled it combines with hemoglobin in the blood, preventing absorption of oxygen and is unlikely to be noticed until the person is overcome. Prolonged exposure to low concentrations or very short exposure to high concentrations can result in asphyxiation and death. Symptoms of carbon monoxide poisoning include:

- Dizziness
- Ringing in the ears
- Unconsciousness
- Headaches
- Nausea

If symptoms are detected, get medical attention as soon as possible. Symptoms of carbon monoxide (CO) poisoning may be confused with seasickness or intoxication, potentially delaying the seeking of medical attention. The poisoning victim's skin often turns cherry red. If CO poisoning is suspected, have the victim breath fresh air deeply. If breathing stops, resuscitate. A victim often revives, then relapses because organs are damaged by lack of oxygen. CO can accumulate in dangerous concentrations anywhere in or around your boat including on back decks, swim platforms, or in water around generator exhaust. CO can remain in or around the boat at dangerous levels even if the engine is no longer running (see Figure 1.6.1). Remember:

- If you smell exhaust you are inhaling CO.
- Change course/speed to improve ventilation.
- Adjusting the canvas enclosure and/or vents and other opening devices can improve ventilation.

To minimize the danger of carbon monoxide accumulation:

- Do not idle the engine without moving the boat for more than 15 minutes at a time.
- Inspect the exhaust system regularly.
- Operate all fuel burning appliances, such as charcoal, propane, LPG, or CNG cooking devices in areas where fresh air can circulate.

## ⚠ DANGER

- **Fumes from the engine(s), generator(s) and other equipment and appliances that burn fuel contain carbon monoxide. Carbon monoxide can kill you. Open all doors, hatches, curtains, and windows to allow fresh air to circulate and dissipate CO present in enclosed spaces, especially when the boat is moored or anchored.**
- **Proper ventilation must be maintained, even during inclement weather to prevent dangerous levels of carbon monoxide build-up.**
- **Sleeping aboard a boat requires a working carbon monoxide detection system, preferably in each sleeping quarter.**

## ⚠ DANGER

**Even in rainy cold weather, ventilation must be maintained to avoid carbon monoxide poisoning. You will get wet and/or cold.**

Carbon Monoxide Accumulation Scenarios  
Figure 1.6.1

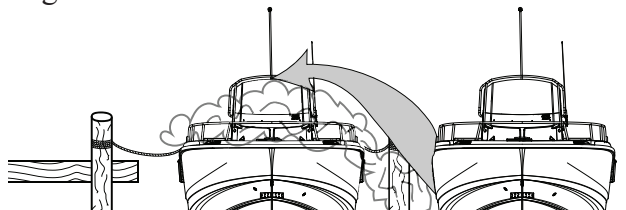

EXHAUST FROM OTHER BOATS.

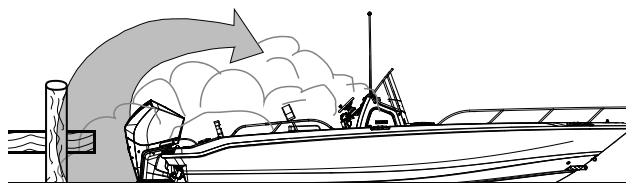

BLOCKAGE OF EXHAUST BY OBSTRUCTION

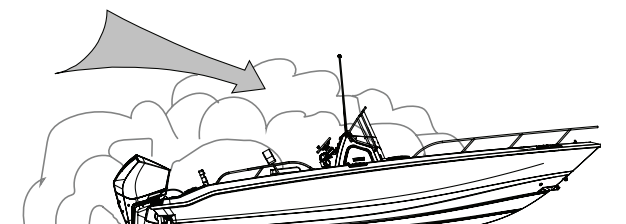

OPERATING AT A HIGH BOW ANGLE

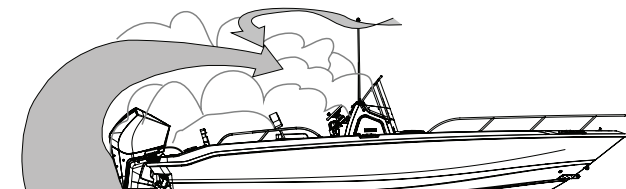

OPERATING AT SLOW SPEED OR WHILE IDLING  
(STATION WAGON EFFECT)

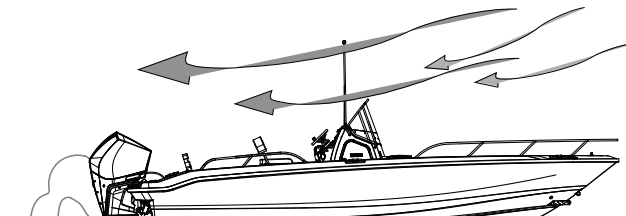

GOOD AIR FLOW  
OPEN ALL HATCHES, PORT LIGHTS OR CANVAS  
OPENINGS TO LET FRESH AIR CIRCULATE.

## Lifesaving Equipment

Even strong swimmers can tire quickly in the water and drown due to exhaustion, hypothermia, or both. The buoyancy provided by a personal flotation device (PFD) allows a person that has fallen overboard to remain afloat with far less effort and body heat loss, extending the survival time required to find them.

### Personal Flotation Devices (PFD)

One USCG approved PFD, Type I, II or III for each person aboard or being towed on water skis, tubes, etc. The law requires that PFDs must be readily accessible, if not worn. Readily accessible means removed from storage bags and unbuckled.

## NOTICE

**Children and non-swimmers must wear PFDs at all times when aboard.**

### PFD Classifications

Listed below are the several different types of PFDs, each life jacket has different purposes, choose one that will suit your purpose.

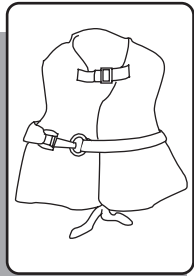

**Type I**, The off-shore life jacket is considered the most buoyant, it is designed to turn an unconscious person face up. Use in all types of waters where rescue may be slow, particularly in cold or rough water conditions.

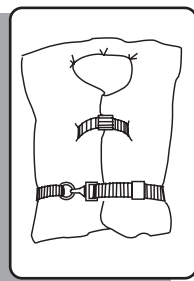

**Type II**, Near-shore life vest, a keyhole vest with flotation filled head and neck support is also designed to turn a person face up, but the turning action is not as pronounced. Use in calm inland waters or where quick rescue is likely.

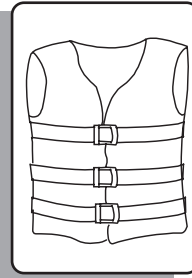

**Type III**, Flotation-aid Life vest is designed so that conscious wearers can turn face-up. Designed for comfort while engaged in water skiing or other forms of water activities.

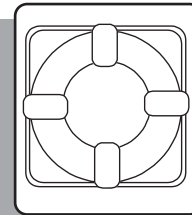

**Type IV**, Throwable Devices, horseshoe buoys, ring buoys and buoyant cushions are designed to be grasped, not worn.



**Type V**, Special-Use devices, sailboat harnesses, white water vests, float coats, and hybrid vests which have minimum inherent buoyancy and an inflatable chamber.

Before purchasing PFDs, ensure that there is an attached tag indicating they are approved by the USCG or by your boating law enforcement agency.

The operator is responsible for instructing everyone onboard on their location and use. The best precaution is to wear the PFD at all times while on the boat.

### Emergency Situations

## NOTICE

**The law requires the owner/operator to assist any person or boat in distress as long as rendering assistance does not endanger the owner/operator, the passengers or the boat.**

Prevention is the safest approach. We hope that you are never involved in an emergency situation, but if you are it is imperative that you react.

### Medical Emergency

You may be far from professional medical help when you are boating. At least two persons on board your boat should be CPR certified, and should have taken a first aid course. Your boat should have a well stocked first aid kit on board. In many situations your radio will be your only link to reaching medical assistance. Keep the radio in working order and understand which channels are used for emergencies, these channels are constantly monitored and will be useful when situations arise. Cell phones can help in some areas, but they are limited and unreliable and should not be used in the place of a good VHF radio.

### Water Rescue

In most situations a person that has fallen overboard will succumb to hypothermia if not rescued immediately. Life expectancy decreases as rescue time increases in water temperatures below 70°F (21.1°C). There are three steps that must be taken when a person has fallen overboard:

#### 1. Returning to the Victim

- Immediately make everyone onboard aware that someone is overboard and keep the victim in sight.
- Slow the boat and keep pointing toward the person overboard. At night or in low light, point the best available light source at the person.
- Throw a life ring/preserver to the victim, even if they are wearing one it will serve as another marker.

#### 2. Making Contact

- Stop or slow the boat and circle toward the person overboard.
- Try to approach heading into the wind or into the waves.
- Keep person overboard constantly in sight.

- When almost alongside, stop the engine in gear to prevent propeller windmilling.

#### 3. Getting Back Aboard

- Try to reach the person overboard with a pole, or by throwing a life preserver. Never swim to them except as a last resort.
- Assist the person in boarding. Boarding should be done at the stern of the boat.
- If the person is injured or incapable of boarding by themselves, a rescuer should don a life preserver with a safety line and enter the water to assist the person onto the boat.
- Handle the person carefully, spinal injuries might have occurred and could be worsened by rough handling.
- Check for other injuries, render medical assistance immediately.

#### Unassisted Reboarding

The reboarding ladder can be deployed to accommodate a person reboarding the boat without assistance.

#### Fire

Fire is a serious boating hazard. Boats will burn quickly. Do not remain onboard and fight a fire for more than a few minutes. If the fire is out of control and cannot be put out with the fire suppression equipment onboard, abandon ship immediately. The fumes released during a fire are toxic and should be avoided. Even after the fire has been extinguished, proper ventilation of the area is required to minimize exposure to harmful fumes.

### DANGER

- **Fires can spread quickly. Have the proper fire fighting equipment close at hand, and in good working order to respond quickly.**
- **Small fire extinguishers have short discharge times. Aim at the base of the fire with a sweeping motion to maximize the use of the fire extinguisher contents.**

To lessen the danger of fire:

- Extinguish all smoking materials, shut off blowers, stoves, engine(s) and generator(s).
- Keep bilge area clean, oil and fuel spills should be cleaned immediately.
- If possible throw burning materials overboard.
- If fire is accessible, release the contents of the fire extinguisher(s) into the base of the fire.
- If the fire is in an enclosed compartment and an automatic fire extinguisher has discharged in the compartment, wait 15 minutes before opening the compartment. Have extinguisher handy in case of a flare up.
- If possible, signal for help. Radio, visual, and audible signal should be used as needed. Also understand, that you must render assistance to any boater requesting help.
- If fire is out of control, grab all necessary survival gear, distress signals, put on personal flotation devices (PFDs) and prepare to abandon ship.
- If you do abandon ship, ensure the passengers have PFDs. Take a head count before entering the water and take another head count when in the water. Stay together.

## **Flooding, Swamping and Capsizing**

In the event of flooding, swamping or capsizing:

### **Flooding**

- Always wear a PFD, or have it within reach.
- If the bilge pump(s) have not automatically turned on, switch them on immediately.
- Find the source of the flooding and determine the best fix.
- Keep the bilge pumps running until the flooding is under control.
- Call for assistance if the source of the flooding cannot be controlled.
- Head back to port if possible.

### **Swamping**

- Always wear a PFD, or have it within reach.

- Swamping is usually a result of wave action, immediately get control of the helm and turn the boat into the waves.
- Swamping can also be caused by an overloaded boat.
- If the bilge pump(s) have not automatically turned ON, switch them ON immediately.
- The deck scuppers on this vessel are designed to drain the deck of water.
- Keep the bilge pumps running until the flooding is under control.
- Take a head count of all passengers.

### **Capsizing**

- Capsized is when a boat is on its side or completely upside-down (usually as a result of wave action, improper loading or load shifting).
- If the boat will not right itself, get out of the water and climb onto the exposed hull.
- Do a head count for all passengers
- Stay together.
- Usually a capsizing will happen quickly and without warning.
- Use whatever is at hand to signal for help.

The chances of flooding, swamping or capsizing can be reduced by being aware of:

- Weather
- Water conditions
- Proper boat handling techniques
- Proper loading of the boat

### **Collision**

In the event of collision:

- Cut the engine(s)
- Check on passengers
- If the bilge pump(s) have not automatically turned on, switch them on immediately.

- Determine amount of damage to boat structure.
- Call for assistance
- In the event of collision you are required to file an accident report. Contact a state enforcement agency or the nearest USCG office. If you are boating outside U.S. waters, consult the nation you are visiting for accident reporting requirements.

### Propulsion, Control or Steering Failure

If there is a propulsion, control or steering failure:

- Stop the engine, (shut off at ignition or pull on the emergency engine shut-off switch).
- Drop anchor outside of the channel, if possible, to prevent drifting.
- Determine if the problem can be fixed or will assistance be needed.
- Call for assistance if needed.

When loss of propulsion or steering is noticed, your quick reaction is required to prevent further damage to your boat or injuries to your passengers.

Outboard engines require propulsion to control the direction the boat will take. Without propulsion, the steering is virtually useless. If you are in a congested waterway you will need to react quickly to warn others that you have lost power, propulsion or steering control and that assistance will be needed.

### Grounding

Running aground may be avoided by paying attention to marker buoys or indicated by waves as they form into breakers when passing over a sand bar. If you do run aground, the course of action depends on how hard the boat hits bottom and whether the boat remains stranded. If it is a simple touch, you may need only to inspect the lower drive of the engine and the hull of the boat. If possible do a thorough inspection before trying to get loose; reversing your boat before this is done may cause more damage.

### Distress Signals

#### Visual Distress Signals (VDS)

- USCG regulations require boats in coastal waters and the Great Lakes to carry a signal (VDS) for day and night use, as well as appropriate for the time of operation. Exempt from the day signals requirement, but not night signals, are boats less than 16 feet (4.8 meters), open sailboats less than 26 feet (7.9 meters) boats participating in organized events and manually propelled boats.
- If you are required to have visual distress signals, at least three safety approved pyrotechnic devices in serviceable condition must be readily accessible. They must be marked with a date showing the service life which must not be expired.
- Carry three signals for day use and three for night. Some pyrotechnic devices meet both day and night use requirements.
- Store pyrotechnic signals in a cool, dry location. Prominently mark an orange or red watertight container *distress signals*.

Other recognized visual distress signals include:

- Flames in a bucket
- Code flags November and Charlie
- Black ball/square on orange background.
- Orange flag (certified)
- Electric distress light (certified) for night use
- Dye marker (any color)
- Person waving arms (slowly)
- U.S. flag flown upside down

#### Audible Distress Signals, (ADS)

USCG regulations require one hand, mouth or power operated whistle or horn, audible for at least 1/2 mile.

Other recognized audible distress signals include:

- Radio communications
- Radio-telegraph alarm
- Position indicating radio beacon
- Morse code S-O-S (3 short 3 long 3 short) sounded by any means.
- Fog horn sounded continuously.

## Radio Communications

A radio is the boat operator's main method of receiving safety information and summoning aid. VHF-FM radio is the primary means of short range communication. Single sideband radio (SSB) is used for longer range communication.

VHF-FM channel 16 and SSB 2182 kHz are designated for emergency use. Such situations can be categorized as:

### EMERGENCY

**MAYDAY, MAYDAY, MAYDAY** - used when life or vessel is in imminent danger.

### URGENCY

**PAN-PAN, PAN-PAN, PAN-PAN** (pronounced PAHN-PAHN)-used when a person or vessel is in some jeopardy less than indicated by a MAYDAY call.

### SAFETY

**SECURITY, SECURITY, SECURITY** (pronounced SAY-CURE-IT-AY) - used for navigational safety or weather warning.

An emergency situation will be hectic and there will not be time to learn proper radio procedure. Learn what to do before you need to do it. If you hear a distress call, stop all radio transmissions. If you can directly assist, respond on the emergency frequency. If you cannot assist, do not transmit on that frequency. However, continue to monitor until it is obvious that help is being provided.

## Weather

### **DANGER**

**Do not attempt to boat in severe weather conditions. Death or serious injury can occur. Get to shore before the weather turns bad.**

Getting caught in severe weather is hazardous. Bad weather and/or rough sea or water conditions can cause an unsafe situation. Consult local weather services for up-to-date forecasts on weather and sea

conditions (see Figure 1.12.1). Television, radio, and internet can give you access to NOAA weather reports that will help you make a determination on where and when to get underway. The following are some weather related rules:

- Understand the design limitations of this vessel.
- Check the weather forecast and water conditions before leaving and while underway.
- Wear a personal flotation device (PFD)
- If bad weather is approaching, immediately seek a safe harbor.
- If bad weather is approaching, immediately seek safe harbor. If bad weather hits, seat passengers in cabin or cockpit deck. Head bow into the wind with enough power to maintain slow headway.
- If you encounter fog, determine your position, set a safe course, slow down and alert other boats of your presence using the appropriate sound signal for your situation at intervals of not more than 2 minutes apart.
- If a lightning storm approaches, the safest action is to dock and disembark. Stay out of the water during a lightning storm. If caught swimming during a storm, get back into the boat and remain there until the storm passes. Remember that lightning can strike several miles away from the storm itself. Be aware of the storm location relative to your location and the direction the storm is moving.

### **WARNING**

**A sudden change in wind direction or speed or an increase in wave height indicates deteriorating weather.**

### **NOTICE**

**Check the weather forecast and water conditions before leaving and while underway**



Weather Warning Pennants  
Figure 1.12.1

### Small craft

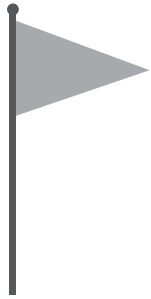

Red flag: Winds to 33 knots (38 mph).

### Gale

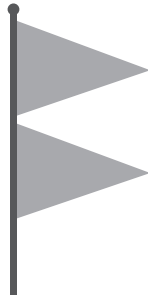

Two red flags: Winds 34-47 knots (39-54 mph)

### Storm

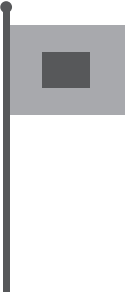

Square red flag with black box: Winds 48-63 knots (55-73 mph)

### Hurricane



Two square red flags with black box: Winds above 64 knots (74 mph)

## Swimming, Diving and Water Skiing

### Swimming

- Do not swim near a moving boat.
- Many areas prohibit swimming from a boat except in designated areas.
- Turn off engine in gear (to prevent propeller windmilling) before picking up swimmer.

### Diving

Recognize and respect diving flags (see Figure 1.12.2). Keep at least 100 feet (30 meters) away.

Diver's Flags  
Figure 1.12.2

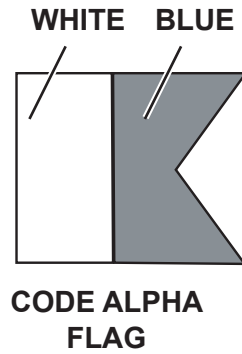
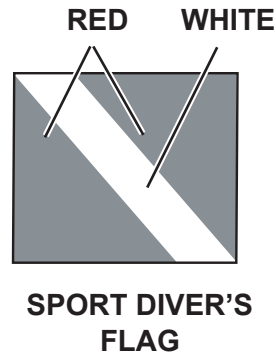

**Sport Divers Flag** - Red flag with diagonal white stripe marks a diver in the water.

**Code Alpha Flag** - Blue and white pennant designates boat being used in dive operations.

### Water Skiing

- Always have two persons in the boat, one at the controls and one who can easily and continuously look at the skier.
- Insist that anyone who water skis must know how to swim.
- Insist that skiers wear approved personal flotation devices (PFD's)
- Ski only in daylight when visibility is good.
- Never drive the boat directly behind a water skier. At 22 knots (25 MPH), it takes only 5 seconds to overtake a fallen skier who was 60 meters (200 feet) in front.
- Ski only in areas where skiing is permitted.
- Observe local restrictions on towline length.
- Learn the signals to communicate with a skier. The skier is to control the boat through hand signals (see Figure 1.13.1).
- This vessel will handle differently while towing a skier. Experiment carefully to learn the difference. Skiers may start from the shore or dock, if boat traffic allows. When returning, pick up skiers from water. Do not ski back to shore or dock.
- Give immediate attention to fallen skiers.

- Keep a downed skier in sight and on the operator's side of the boat when approaching the skier. Never back up to person in the water.
- Turn off engine before picking up skier.
- If the skier suddenly releases the tow rope, it can backlash into cockpit. Spotters who are watching the skier must be aware of this fact and be prepared to take appropriate action to avoid injury.

## Water Skiing Signals

Figure 1.13.1

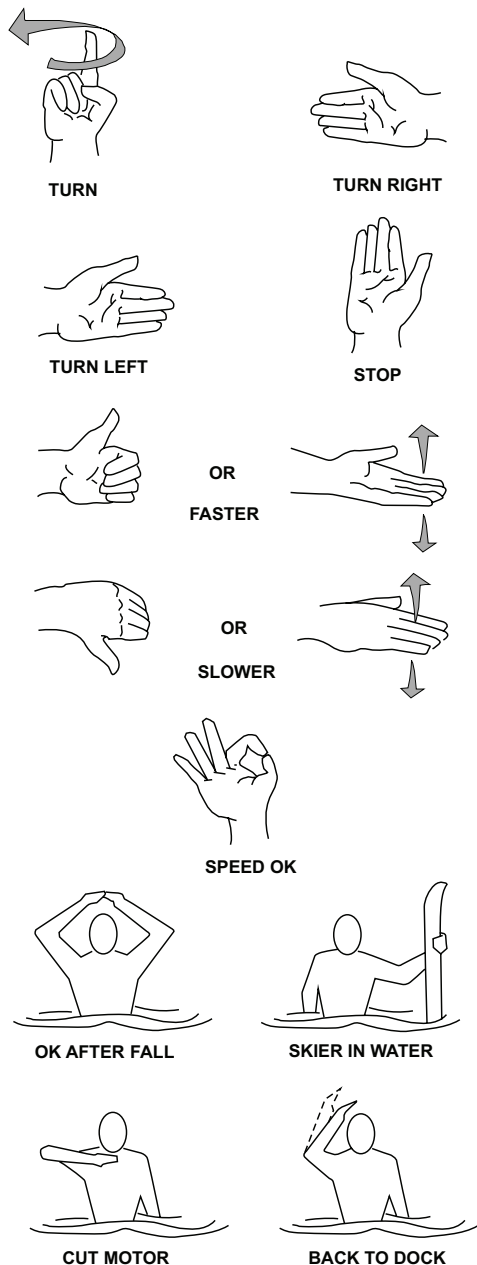

- Turn** – Arm raised, circle with index finger extended.
- Turn Right** – Extend arm out from body to the right.
- Turn Left** – Extend arm out from body to the left.
- Stop** – Raise arm with palm vertical and facing forward.
- Faster** – Thumb up or palm up, move hand up and down.
- Speed OK** – Raise arm and make OK symbol with thumb and index finger
- Slow Down** – Thumb down or palm down, move hand up and down.
- OK After a Fall** – Clasp hands together overhead.
- Skier in Water** – Extend one ski vertically out of water.
- Cut Motor** – Draw finger across throat.
- Back to Dock** – Pat top of head.

### **WARNING**

#### **SWIMMING/DIVING HAZARD**

- Keep clear of areas designated/marked for only swimmers and divers only.
- Never swim when there is lightning.

#### **SKIING HAZARDS**

- Skiers must use a safety approved personal flotation device (PFD).
- Ski only during daylight and in good visibility.
- Avoid shallow water, other boats, navigational aids and other obstructions.
- Keep at least 100 feet from other objects.
- Never follow directly behind a water skier.
- A competent observer must watch skier at all times. A competent observer is a person that has the ability to assess when a skier is in trouble, knows or understands water skiing hand signals and is capable of helping a skier.
- Keep a downed skier in constant sight.
- Turn off engine in gear before you get close to person in the water.
- Never back up to anyone in the water.
- Use caution in boat when skier is being towed. Sudden release of tow rope can cause it to backlash into the cockpit

**⚠ DANGER**

**PROPELLER SAFETY**

- Before starting boat, walk to stern to inspect water to assure there is no one near propeller. People near propeller may not be visible from helm.
- Never allow passengers to board or exit boat from in the water when engines are on.
- Educate passengers about propeller danger.
- Be especially alert operating in congested areas; never enter swimming zones.
- Take extra precautions near boats that are towing skiers or tubers.
- Never permit passengers to ride on bow, gunwale, transom, seatbacks, or other locations where they could fall overboard.
- If someone falls overboard, slowly turn boat around and keep the person in sight as you approach. Turn engine off with boat in gear before bringing the person aboard.
- Never reverse vessel to pick someone up out of the water.

**Towed Inflatables**

**ATTENTION**

Ski tow pylons / tower / hardtop /ski eye tow points are not designed for use with tubes. The added stress of the tube may cause a dangerous recoil or damage the equipment. Damage to the pylon / tower / hardtop / ski tow eye is not covered by the boat or equipment manufacturer's warranty if misused. When towing inflatables/ tubes, use both stern eye strong points with a tube tow harness to attach the tube tow rope.

Towed inflatable types, aka tubes, produce tremendous stress on the tow point and rope, far greater than devices like waterskis, kneeboards or wakeboards. When pulling a tube use both stern eye strong points in combination with a proper tube harness and tow rope. Parasails and kites should never be used with a recreational boat.

**Engine Emergency Stop Switch**

**⚠ WARNING**

**Wear lanyard at all times when operating boat. Use it to stop only in an emergency. Do not use it to shut off the engine during normal operation.**

Engine Emergency Stop Switch  
Figure 1.14.1

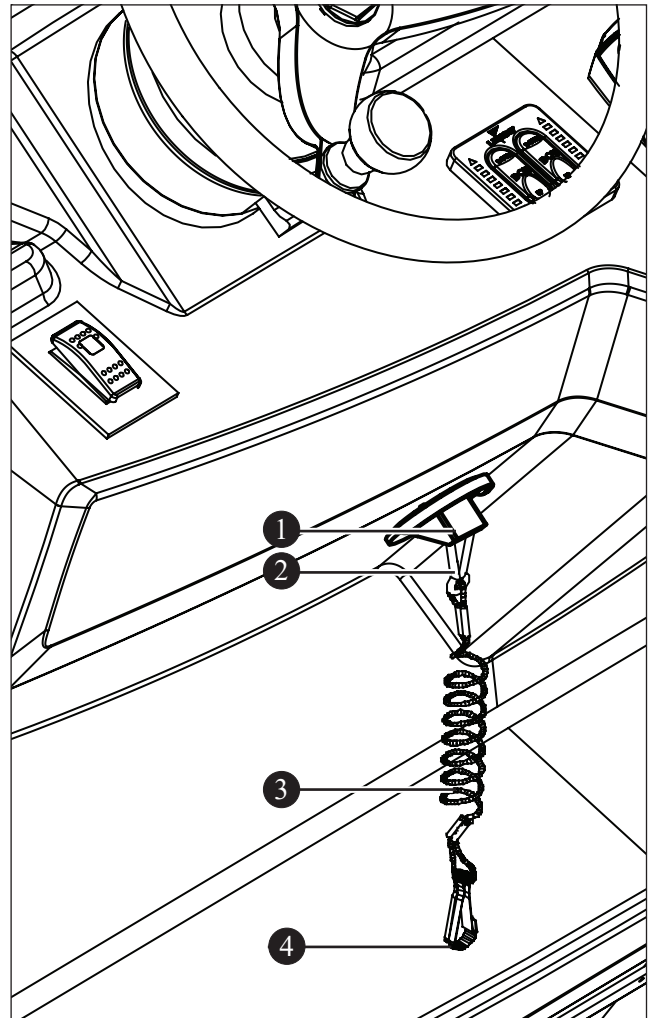

- 1 ENGINE EMERGENCY STOP SWITCH
- 2 HELM SWITCH CLIP
- 3 LANYARD
- 4 OPERATOR SWITCH CLIP

This vessel is equipped with an engine emergency stop switch. The switch is located at the helm. The engine shut down safety switch incorporates a shut-off switch, switch clip, lanyard and lanyard clip, which is clipped to the operator when running (see Figure 1.15.1). If an

emergency arises and the engine must be shut down, a pull on the cord to release the clip from the shut-off will shut off the engine.

This switch is designed to shut the engine off when the operator of the boat leaves the control station, either accidentally by falling into the boat, or by being ejected overboard. This would most likely occur as a result of poor operating practices.

The lanyard should be long enough to prevent accidental activation. Do not let the lanyard become entangled. Accidental loss of power can be hazardous, particularly while docking or in heavy seas, strong current or high winds. Passengers and crew may lose balance and the boat may lose steering control.

Should the operator fall out of the boat at planing speed, it may take several seconds for the engine and propeller to stop turning. The boat may continue to coast for several hundred feet, causing injury to anyone in its path.

### **1st Mate™ Safety and Security System (Option)**

1st Mate is a marine safety and security system that syncs an engine-integrated hub to wearable fobs and the mobile app\*, providing alerts to the captain and passengers should anyone go overboard. This system delivers an added level of safety beyond the engine shut-down system that links the captain's lanyard to the engine emergency stop switch. The 1st Mate system offers multiple, customizable security settings including:

- Man overboard alerts should a passenger(s) fall overboard, and engine shutdown should the captain fall overboard.
- Distress messaging and GPS location alerts sent to connected mobile devices.
- Theft-deterrent functionality including wireless engine(s) lock and/or reduced RPMs to prevent unauthorized use

For more information, see the owner's packet or contact an authorized Boston Whaler dealer.

\*Download the 1st Mate app at: [1stmate.net](http://1stmate.net)

### **Float Plan**

Float plans are important to you should you encounter problems on the water. A float plan should

contain a description of this vessel along with any distinguishing features. It should describe where you will be boating, your departure time and estimated return. The number and names of passengers, and destination should also be noted. The float plan should be given to a friend or relative, so they can give the information to a national boating agency like the USCG, in the event you do not return at the time specified on the float plan. If there are any changes to the float plan they should be conveyed to the person holding the float plan. Once you return you should contact the person holding the float plan to let them know you are back.

### **Chart Course**

To avoid boating in unsafe areas where there are underwater obstructions, shallow water, unnavigable conditions such as dangerous currents, and others, you must chart a course. This means having and using National Oceanic and Atmospheric Administration (NOAA) charts for coastal waters, observing and understanding all navigational aids, using the knowledge and guidance of experienced boaters, and being aware of the tides and times where appropriate. If you are boating in an area you are unfamiliar with, proceed with caution and post a lookout to watch for hazards.

### **WARNING**

**Hitting an object in or under the water or boating in dangerous currents can cause serious injury or death to occupants in the boat. You must know where the hazards are and avoid them. In uncharted waters, boat very slowly and post a lookout.**

If an object is struck or if you run aground:

- Shut the engine off
- Check the hull and propeller for damage
- If aground, consider bottom grade before moving off to not worsen damage.
- Determine the tides and whether that change will help or hinder your situation.
- Do not have anyone other than a trained and competent service tow your boat.

## Environmental Considerations

### Fuel and Oil Spillage

Regulations prohibit discharging fuel or oily waste in navigable waters. Discharge is defined as any action which causes a film, sheen or discoloration on the water surface, or causes a sludge or emulsion beneath the water surface. A common violation is bilge discharge. Use rags or sponges to soak up fuel or oily waste, then dispose of it properly ashore. If there is much fuel or oil in the bilge, contact a knowledgeable marine service to remove it. Never pump contaminated bilge overboard. Help protect your waters.

### Excessive Noise

Many areas regulate noise limits. Even if there are no laws, courtesy demands that boats operate quietly.

### Wake

#### **WARNING**

**Speed hazard, watch your wake. It might capsize a smaller craft. You are responsible for damage caused by your wake.**

#### **CAUTION**

**Reduce speed in a congested waterway. Be alert for no wake markers.**

Power boat wakes can endanger people and vessels. Each power boat operator is responsible for injury or damage caused by the boat's wake. Be especially careful in confined areas such as channels or marinas. Observe *no wake* warnings.

## Homeland Security Restrictions

- Recreational boaters have a role in keeping our waterways safe and secure. Violators of the restrictions below can expect a quick and severe response.
- Do not approach within 100 yards, and slow to minimum speed within 500 yards of any U.S. Navy vessel.
- Observe and avoid all security zones. Avoid commercial port areas, especially those that involve military, cruise line or petroleum facilities. Observe and avoid other restricted areas near dams, power plants, etc.
- Do not stop or anchor beneath bridges or in channels.

## America's Waterway Watch

In 2005, the United States Coast Guard officially launched *America's Waterway Watch* to encourage the boating public to report suspicious activities in our nation's ports and waterways. *America's Waterway Watch* simply asks anyone who works, lives, or recreates on the water to keep an eye out for suspicious activities. Anyone who spots such activity is asked to call the National Response Center's 24-hour hotline or 877-24WATCH (877-249-2824). If there is immediate danger to life or property call 911 or the USCG on marine channel 16.

## Safety Label Locations

Mounted at key locations throughout the boat, safety labels advise the owner/operator of imperative safety precautions to follow when operating and/or servicing equipment. Do not remove or obstruct any label. Replace any label which becomes illegible (see *Label Locations* section next in this chapter).

## Label Locations

**IMPORTANT: Replace any damaged or illegible labels. Contact your dealer to obtain replacements.**



2156485

**B** **WARNING**

Operating, servicing and maintaining a recreational marine vessel can expose you to chemicals including engine exhaust, carbon monoxide, phthalates, and lead, which are known to the State of California to cause cancer and birth defects or other reproductive harm. To minimize exposure, avoid breathing exhaust, service your vessel in a well-ventilated area and wear gloves or wash your hands frequently when servicing this vessel. For more information go to [www.P65warnings.ca.gov/marine](http://www.P65warnings.ca.gov/marine).

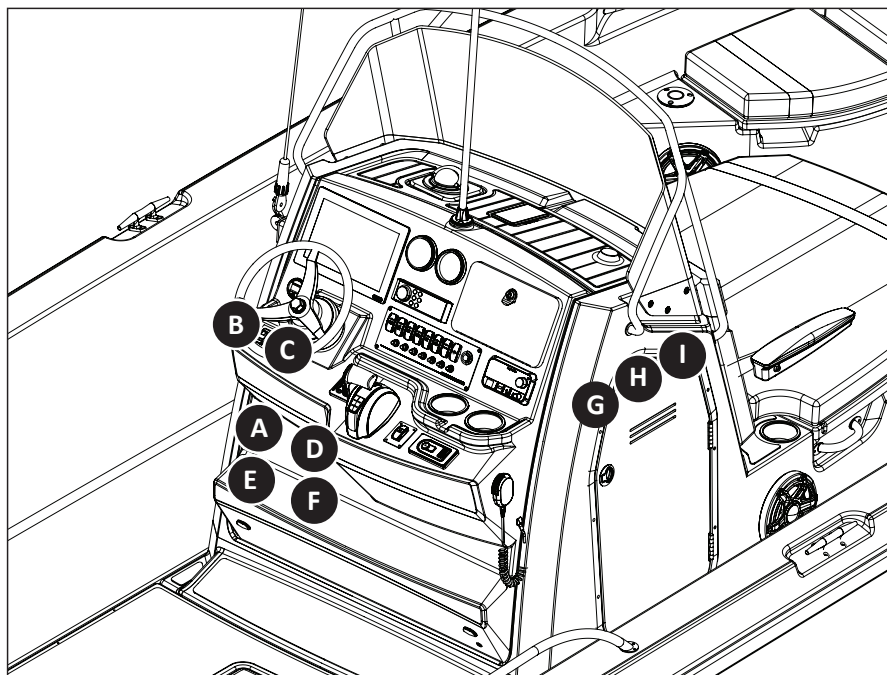

**D** **WARNING**

**ROTATING PROPELLER MAY CAUSE SERIOUS INJURY OR DEATH. SHUT OFF ENGINE WHEN NEAR PERSONS ARE IN WATER**

1950698

**C**

**LOOK BEFORE YOU PUMP!**

**USE E10 FUEL**

Do not use any fuel containing greater than 10 percent ethanol (E10) in this equipment. It may cause damage or failure and is prohibited by Federal Law. For more information, see [www.LookBeforeYouPump.com](http://www.LookBeforeYouPump.com)

Ethanol Percentage

10% OK NO 15% - 30% - 85%

2304853

**E** **WARNING**

**FAILURE TO FOLLOW THESE GUIDELINES CAN RESULT IN INJURY OR DEATH**

USE CAUTION WITH SKIER IN TOW AS THE TOW ROPE MAY SNAP BACK INTO COCKPIT WHEN RELEASED  
 TOWER RATED FOR WATER SKIING OR WAKE BOARDING USE ONLY  
 ALL OTHER RECREATIONAL TOWABLES USE TRANSOM STERN EYES  
 DO NOT TOW OTHER BOATS OR USE FOR PARASAILING  
 DO NOT JUMP OFF OR DIVE FROM TOWER  
 NEVER ALLOW LOOSE TOW ROPE ENDS TO HANG FROM TOWER  
 ENSURE STRUCTURAL INTEGRITY OF TOWER AND ATTACHMENT POINTS ON VESSEL PRIOR TO USE

1851556

**F** **WARNING**

Carbon monoxide (CO) can cause brain damage or death.  
 Engine and generator exhaust contains odorless, colorless CO gas.  
 For additional information on CO poisoning, see *Owner's Manual*.  
 At first sign of CO poisoning, get to fresh air.  
 Signs of CO poisoning include nausea, headache, dizziness, drowsiness, and unconsciousness.

1811368

**G** **WARNING**

**DOOR MUST BE SECURED IN THE CLOSED POSITION WHILE VESSEL IS UNDERWAY.**

2063402

**H** **WARNING**

**NO VENTILATION IS PROVIDED. FUEL VAPORS ARE A FIRE AND EXPLOSION HAZARD. TO AVOID INJURY OR DEATH, DO NOT STORE FUEL OR FLAMMABLE LIQUIDS HERE.**

1691003

For Canadian vessels

**I** **AVERTISSEMENT**

**NE STOCKEZ PAS D'ESSENCE OU AUTRES LIQUIDES INFLAMMABLES À CET ENDROIT. LA VENTILATION N'A PAS ÉTÉ PRÉVUE POUR LES VAPEURS EXPLOSIVES.**

2175076

## Label Locations

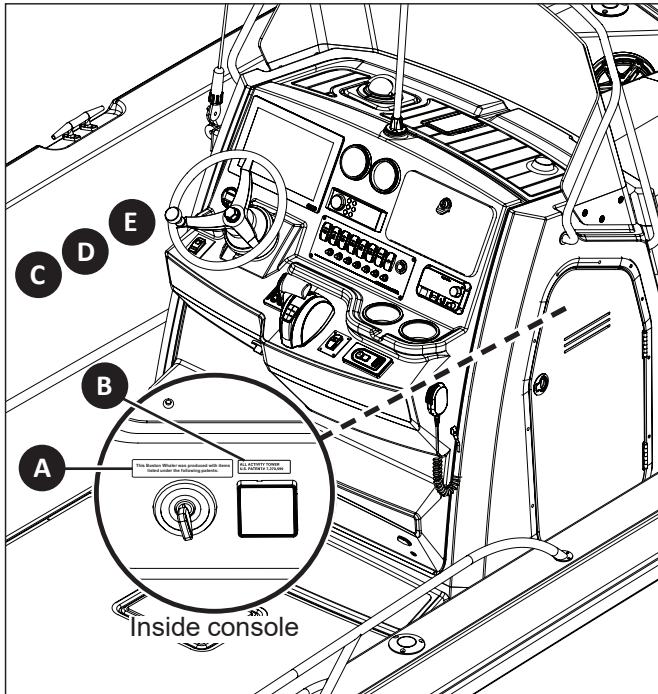

This Boston Whaler was produced with items listed under the following patents:

**A**

2088481

**B**

ALL ACTIVITY TOWER  
U.S. PATENT #7,370,599

2063994

**C**

Vessel's certification plate (see chapter 2, *General Information*).

### EMISSIONS CONTROL SYSTEM INFORMATION

MEETS 2023 MY CALIFORNIA EVAP EMISSIONS REGULATIONS FOR SPARK-IGNITION MARINE WATERCRAFT (SIMW)

MANUFACTURER: **BOSTON WHALER, INC.**

CALIFORNIA EVAP FAMILY: **PBNWPVSSLTB1**

EMISSION CONTROL SYSTEM: **SP**

**D**

2397619

**THIS BOAT HAS BEEN DESIGNED FOR A MAXIMUM OUTBOARD ENGINE WEIGHT OF**

**720 lb / 326 kg**

**E**

1774307

**IMPORTANT:** Replace any damaged or illegible labels. Contact your dealer to obtain replacements.

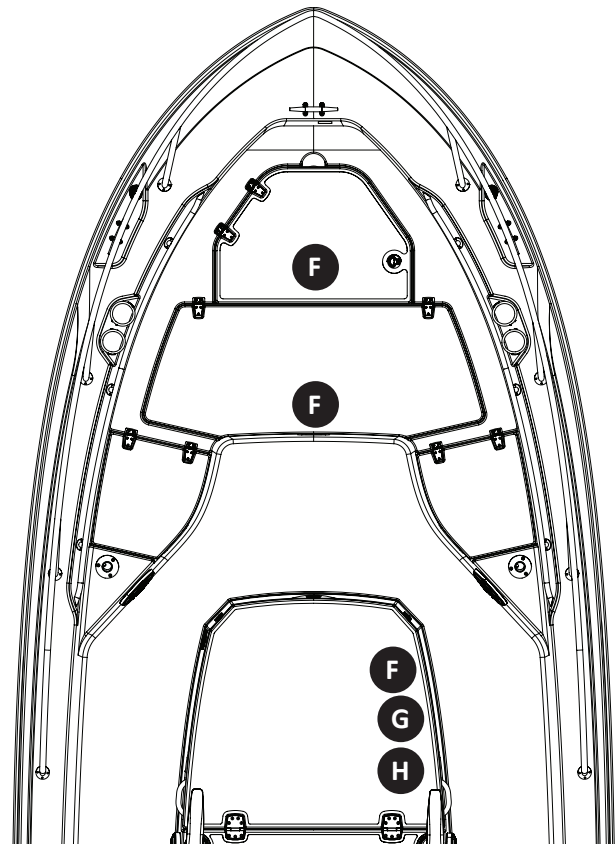

**F**

**CAUTION**

AVOID INJURY  
BOAT MOVEMENT MAY CAUSE LID TO FALL  
KEEP HANDS AND FEET CLEAR OF EDGES WHEN  
HATCH IS OPEN

1836858

**G**

**WARNING**

NO VENTILATION IS PROVIDED.  
FUEL VAPORS ARE A FIRE AND EXPLOSION  
HAZARD. TO AVOID INJURY OR DEATH, DO NOT  
STORE FUEL OR FLAMMABLE LIQUIDS HERE.

1691003

For Canadian vessels

**H**

**AVERTISSEMENT**

NE STOCKEZ PAS D'ESSENCE OU  
AUTRES LIQUIDES INFLAMMABLES À  
CET ENDROIT. LA VENTILATION N'A  
PAS ÉTÉ PRÉVUE POUR LES  
VAPEURS EXPLOSIVES.

2175076

## Label Locations

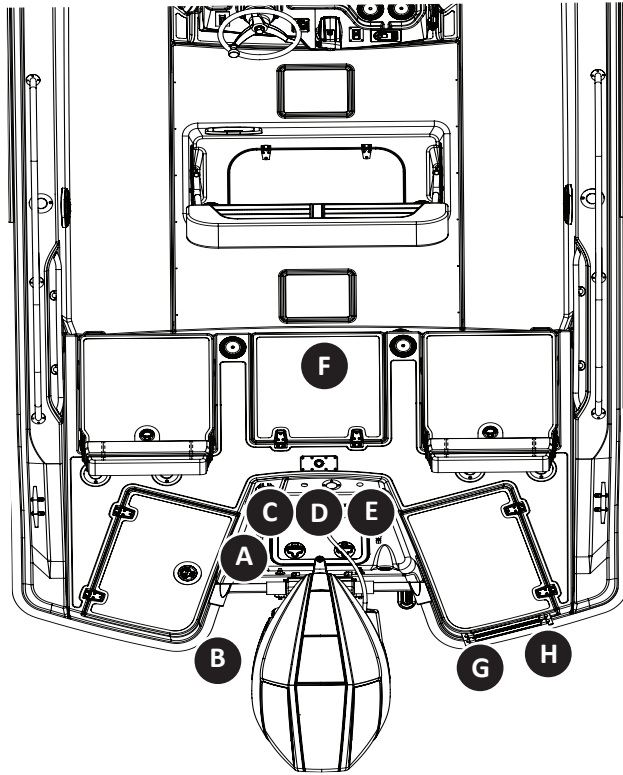

2184707

For all activities tower, tow arch, hardtop, and T-top (not shown)

**B** **! WARNING**

- SKI PYLON MUST BE SECURED WHEN IN USE
- TOW ROPE MAY BACKLASH INTO COCKPIT
- DO NOT USE TO TOW ITEMS THAT ARE ATTACHED TO TOW ROPE SUCH AS TUBES OR OTHER TOWABLES
- DO NOT USE SWIM PLATFORM WHEN ENGINE IS RUNNING

1590140

**C** **! WARNING**



Avoid serious injury or death from fire or explosion resulting from leaking fuel. Inspect system for leaks at least once a year.

The use of fuels containing ethanol higher than 10% (E-10) can damage your engine or fuel system and will void the warranty. Never use (E-85).

2096004

**IMPORTANT:** Replace any damaged or illegible labels. Contact your dealer to obtain replacements.

For Canadian vessels

**D** **! AVERTISSEMENT**

LES FUITES DE CARBURANTS PRÉSENTENT UN DANGER D'INCENDIE OU D'EXPLOSION. INSPECTER RÉGULIÈREMENT LE SYSTÈME. VÉRIFIER LES RÉSERVOIRS DE CARBURANTS POUR DÉCELER DES FUITES OU DE LA CORROSION AU MOINS UNE FOIS L'AN.

2175077

**E** **NOTICE**

**GASOLINE RECOMMENDATIONS**

Minimum octane rating of 91 in the U.S. and Canada. Minimum octane rating of 96 outside the U.S. and Canada. Refer to engine manual for additional information.

2038447

**F** **! CAUTION**

**AVOID INJURY**  
BOAT MOVEMENT MAY CAUSE LID TO FALL  
KEEP HANDS AND FEET CLEAR OF EDGES WHEN HATCH IS OPEN

1836858

**G** **! WARNING**

**ROTATING PROPELLER MAY CAUSE SERIOUS INJURY OR DEATH. DO NOT APPROACH OR USE LADDER WHEN ENGINE IS RUNNING.**

1903624

**H** **! DANGER**



Carbon monoxide (CO) can cause brain damage or death.  
Engine and generator exhaust contains odorless and colorless CO gas.  
CO will be around the back of the boat when engines or generators are running.  
Move to fresh air if you feel nauseous, headache, dizziness or drowsiness.

1811367



## Symbols Key

Although not used in this manual, some of these symbols may be found on this vessel's controls, gauges, and hardware. This page is the key to what the symbols mean.

					
ENGINE EXHAUST CONTROL	ENGINE	ENGINE START	ENGINE STOP	WARNING ELECTRICAL HAZARD	FIRE RISK
					
FUEL GENERAL	FUEL LEVEL	LEADED FUEL	UNLEADED FUEL	ENGINE COOLANT WATER JACKET TEMPERATURE	ENGINE OIL PRESSURE
					
FUEL FILTER	ENGINE ROTATIONAL SPEED	BILGE PUMP	OUTBOARD DRIVE	OUTBOARD DRIVE TILT	PROPELLER
					
SEAWATER	SEWAGE	BILGE BLOWER	SINGLE LEVER CONTROL	LIFT POINT / SLING LOCATION	LIFT POINT
					
RUNNING LIGHTS UNDER POWER	ROTARY CONTROL (WIDTH OF SYMBOL INDICATES INCREASE)	ANCHOR	ANCHOR LIGHT	INTERIOR LIGHT	HORN
					
WINDSHIELD WIPER AND WASHER	MAGNETIC COMPASS	PROPULSION SYSTEM TRIM BOW UP	PROPULSION SYSTEM TRIM BOW DOWN	PROPULSION SYSTEM TRIM	TRIM TAB TRIMMING OPERATION
					
FRESHWATER	GRAY WATER	OIL	BATTERY	CONTROL LEVEL OPERATION DIRECTIONS	WATER PUMP
					
ACCESSORY	NO OPEN FLAME NO SMOKING				

## Construction Standards

Boston Whaler® is dedicated to creating a superior product which provides comfort, performance, safety, and reliability. All of our boats comply with United States Coast Guard safety standards and are designed, engineered, and manufactured in accordance with applicable recommendations and guidelines from the American Boat and Yacht Council (ABYC) and certified by the National Marine Manufacturers Association (NMMA).

## Hull Construction

Boston Whaler hulls are constructed with our patented unbond-construction process (see Figure 2.1.1). This involves foam injection into a closed-mold system where the foam expands to fill all voids in the hull. When the finished product is pulled from the mold, the hull and deck are chemically bonded to form a solid, inseparable unit.

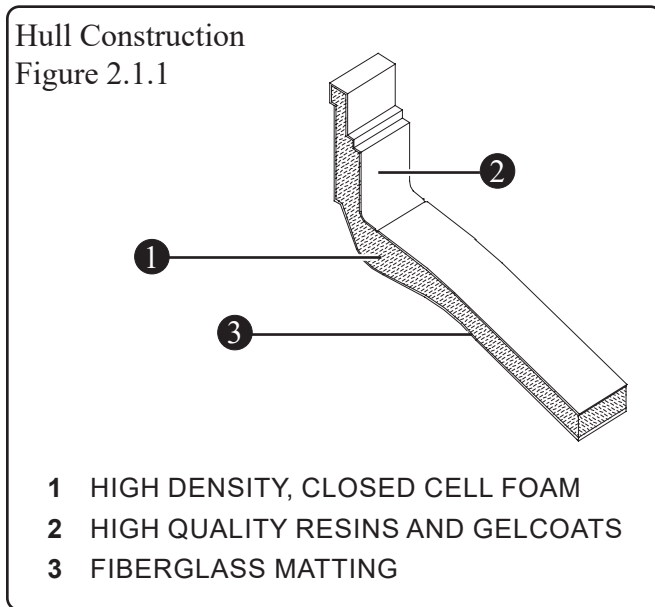

## Hull Identification Number

The hull identification number is located on the starboard side of the transom (see Figure 2.1.2). This is the most important identifying factor on this vessel, followed by the engine serial number. Be sure to reference these numbers when contacting Boston Whaler about the vessel or engine.

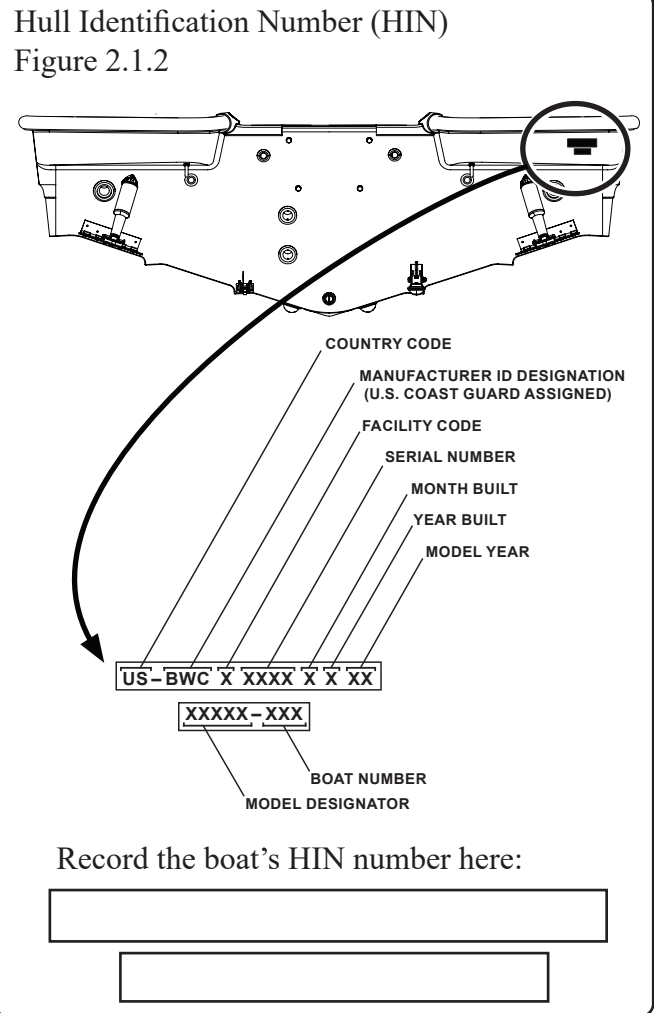

## Vessel Servicing

When this vessel requires service or maintenance work it should be taken to an authorized Boston Whaler dealer. To find a dealer in your area call 800-942-5379 (domestic/international). In the unlikely event that a problem is not handled to your satisfaction, discuss any warranty related problems directly with the service manager of the dealership or your sales person. Please give the dealership an opportunity to help the service department resolve the matter for you.

## Manufacturer's Certification

All boats must comply with federal regulations, where applicable. The specifications and dimensions table, listed later in this chapter, indicates the maximum weight, number of persons, and maximum horsepower this vessel is rated to handle. Do not exceed these specifications.

### Manufacturer's Certification

All boats must comply with federal regulations regarding maximum capacities. The *Specifications and Dimensions* table, listed later in this chapter, indicates the maximum weight, number of persons, and maximum horsepower this vessel is rated to handle. Do not exceed these specifications. The information on the certification plate does not relieve the operator of responsibility. Use common sense and sound judgement when placing equipment and/or passengers in this vessel. Do not load to capacity in poor weather/rough water. The number of seats does not indicate passenger capacity in poor weather/rough water. At speeds above idle, all passengers should be seated on the seats provided.

**⚠ DANGER**

**Never carry more weight or passengers than indicated on the certification plate, regardless of weather or water conditions.**

### Certification Plates

*NOTE: The type of capacity plate varies depending on the local governing authority.*

#### NMMA Plate

An NMMA Certification indicates that your boat has been verified by the National Marine Manufacturers Association (NMMA) to be in compliance with applicable federal regulations and American Boat and Yacht Council (ABYC) standards. Recreational vessels up to 20 feet (6.1 meters) have passenger and cargo weight capacities compliant with USCG regulations. Vessels 26 feet (7.9 meters) and under have passenger and cargo weight capacities compliant with ABYC standards. Vessels over 26 feet have NMMA yacht certification.

**MAXIMUM CAPACITIES**

**10 PERSONS OR 1650 LBS.**

**2735 LBS. PERSONS, MOTOR, GEAR  
400 H.P. MOTOR**

THIS BOAT COMPLIES WITH U.S. COAST GUARD SAFETY STANDARDS IN EFFECT ON THE DATE OF CERTIFICATION

MANUFACTURER: BOSTON WHALER, INC.  
MODEL: 25DNT EDGEWATER, FL

DESIGN COMPLIANCE WITH NMMA REQUIREMENTS IS VERIFIED.  
MANUFACTURER RESPONSIBLE FOR PRODUCTION CONTROL.



NATIONAL MARINE  
MANUFACTURERS  
ASSOCIATION

MEETS U.S. EPA EVAP STANDARDS USING CERTIFIED COMPONENTS

2351112

#### Canadian Conformity Plate

A Canada Compliance Notice indicates that your boat has been certified to comply with construction standards for small vessels by Transport Canada (TC). Recreational vessels up to 6 meters (19.7 feet) have passenger and cargo weight capacities compliant with TC regulations. Vessels over 6 meters are also compliant with TC regulations, but do not state capacities on the plate.

**CANADIAN COMPLIANCE NOTICE  
AVIS DE CONFORMITE CAÑADIEN**

Boston Whaler (BWC)  
Edgewater, FL, USA

MODEL / MODLÈ: 250 DAUNTLESS

DESIGN CATEGORY: C

THE MANUFACTURER DECLARES THAT THIS VESSEL COMPLIES WITH THE PLEASURE CRAFT CONSTRUCTION REQUIREMENTS OF THE SMALL VESSEL REGULATIONS, AS THEY READ ON THE DAY ON WHICH THE CONSTRUCTION OF THE VESSEL WAS STARTED OR ON THE DAY ON WHICH THE VESSEL WAS IMPORTED.

LE FABRICANT ATTESTE QUE CE BÅTIMENT EST CONFORME AUX EXIGENCES DE CONSTRUCTION DES EMBARCATIONS DE PLAISANCE DU RÈGLEMENT SUR LES PETITS BÅTIMENTS, EN VIGUEUR Å LA DATE DU DÈBUT DE SA CONSTRUCTION OU Å LA DATE DE SON IMPORTATION.

2351194

### CE Mark Builder's Plate

A CE mark indicates that your boat has been certified for the EU and the passenger and cargo weight capacities comply with the International Organization for Standardization (ISO) regulations.

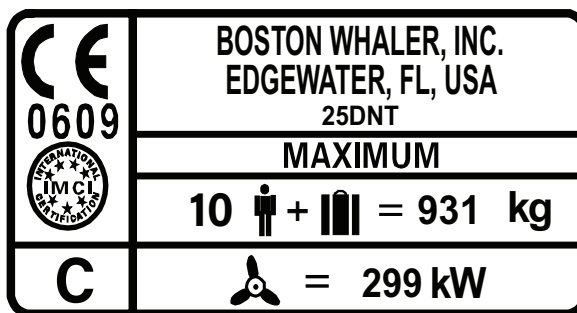

2399387

### Australian Builder's Plate

An Australian Builder's Plate indicates that your boat has been certified and the passenger and cargo weight capacities comply with either the International Organization for Standardization (ISO) regulations or American Boat and Yacht Council (ABYC) standards as noted on the capacity plate.



2351108

### Emission Control System Plate

An Emissions Control System Information plate indicates that your boat is compliant with California emissions regulations.

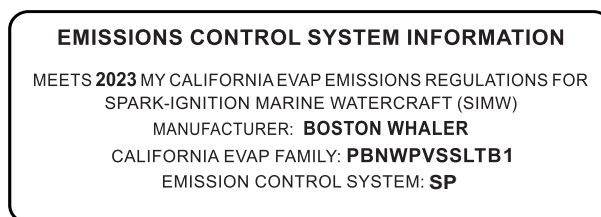

2397619

### Certification Design Category

#### NOTICE

The 250 Dauntless is design category C

Boats are classified into four categories depending on their propensity to withstand both the force of the wind and height of the waves. The categories (A, B, C, D) are designed to sensitize the boat operator to navigate safely. The Beaufort Scale is used to classify the force of the wind ranging from 0 (calm) to 12 (hurricane). Devised by Francis Beaufort of the British Navy, the scale offers a uniform description of the effect of different winds at sea.

**A:** A recreational craft given design category A is considered to be designed for winds that may exceed wind force 8 (on Beaufort scale) and significant wave heights of 4 meters and above but excluding abnormal conditions, such as storm, violent storm, hurricane, tornado and extreme sea conditions or rogue waves.

**B:** A recreational craft given design category B is considered to be designed for a wind force up to, and including, 8 and significant wave heights up to, and including 4 meters.

**C:** A watercraft given design category C is considered to be designed a wind force up to, and including 6 and significant wave heights up to, and including, 2 meters.

**D:** A watercraft given design category D is considered to be designed for a wind force up to, and including 4 and significant wave heights up to, and including 0.3 meters, with occasional waves of 0.5 meters.

The significant wave height is considered to be the primary factor for determining design category. Other parameters (e.g., meteorological) are descriptions of when these wave heights may be expected to occur.

### Power Capacity

The *Specifications and Dimensions* list on the following page indicates the maximum rated power listed for this vessel. Do not exceed this rating. The various engine types offered today are more powerful and require constant maintenance to stay at optimal

performance. The operator must read all information regarding the safety features, warning notices and maintenance schedules for safe operation of the engine.

The engine on this vessel has been tested and proven to be best suited for general use under normal conditions and load.

If you are re-powering this Boston Whaler, you should pay particular attention to the maximum/minimum horsepower and maximum safe engine weight load this vessel is rated for. There is a maximum engine weight label located starboard of the helm seat.

#### NOTICE

The 250 Dauntless is designed for a maximum outboard engine weight of 690 lbs (313 kg).

#### WARNING

- Do not exceed the maximum engine power rating stated on the certification plate.
- Use caution while accelerating. Make sure passengers are safely seated in designated areas of the boat and all gear is stowed securely.

#### NOTICE

Always adjust the speed and direction of the craft to the varying sea conditions.

## Chapter 2 • General Information

### Specifications and Dimensions (measurements are approximate and subject to variance)

A	Overall length (engine up)	29' 8" (9.05 m)	R	Bridge clearance (T-top light up)	8' 8" (2.64 m)
B	Overall length (engine down)	27' 8" (8.43 m)	T	Bridge clearance (Hardtop)	8' (2.43 m)
C	Hull length (bow to transom)	24' 9" (7.53 m)	U	Bridge clearance (Hardtop light up)	9' 5" (2.86 m)
D	Hull length (bow to swim platform)	25' 8" (7.82 m)		Swamped capacity	5600 lbs (2540 kg)
E	Overall height	8' 9" (2.66 m)		Maximum engine weight	690 lbs (313 kg)
F	Bow to anchor roller	4.5" (.11 m)		Max weight (passengers, engines, gear <sup>2</sup> )	2735 lbs (1240 kg)
G	Beam	8' 6" (2.59 m)		Max weight (passengers, gear <sup>2</sup> )	2053 lbs (931 kg)
H	Draft (engine down) <sup>1</sup>	2' 11" (.88 m)		Maximum persons' capacity	10
J	Draft (engine up) <sup>1</sup>	1' 5" (.42 m)		Maximum horsepower	400 HP (299 kW)
M	Freeboard (midship)	2' 11" (.89 m)		Minimum horsepower	250 HP (186 kW)
N	Bridge clearance	6' 1" (1.85 m)		Fuel capacity	95 gal (360 L)
P	Bridge clearance (T-top)	7' 11" (2.41 m)		Weight (fuel, water, engine)	4740 lbs (2150 kg)

<sup>1</sup> Optional equipment and loading of the boat affects draft measurements. Follow the recommendations listed on the capacity plate regarding the maximum amount of weight this vessel can safely carry.

<sup>2</sup> Exceeding maximum weight affects boat performance. Do not exceed the weight listed on the capacity plate.

### Dimensions and Clearances

Figure 2.5.1

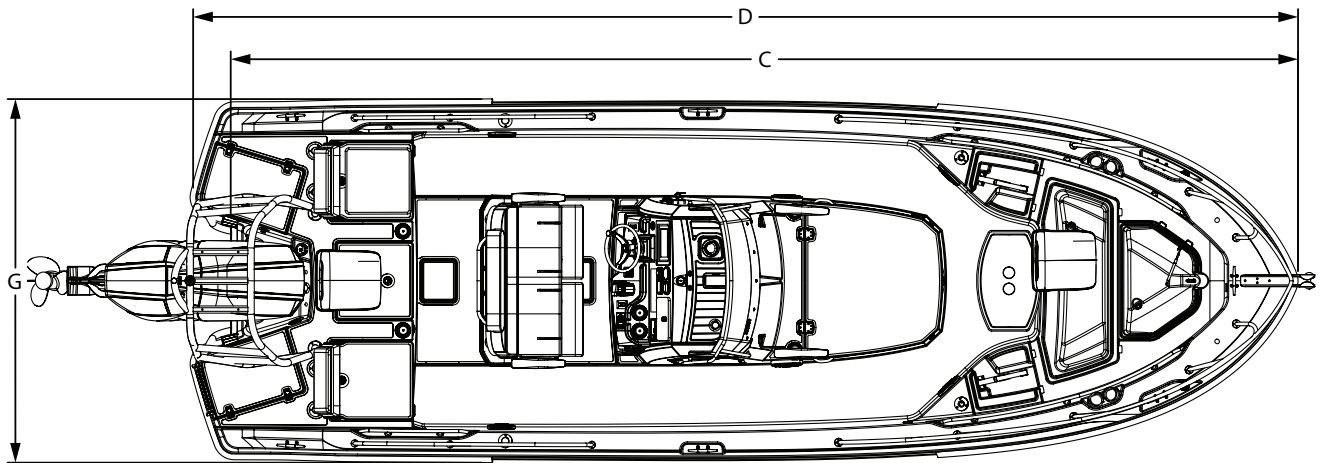

Dimensions and Clearances (Continued)  
Figure 2.6.1

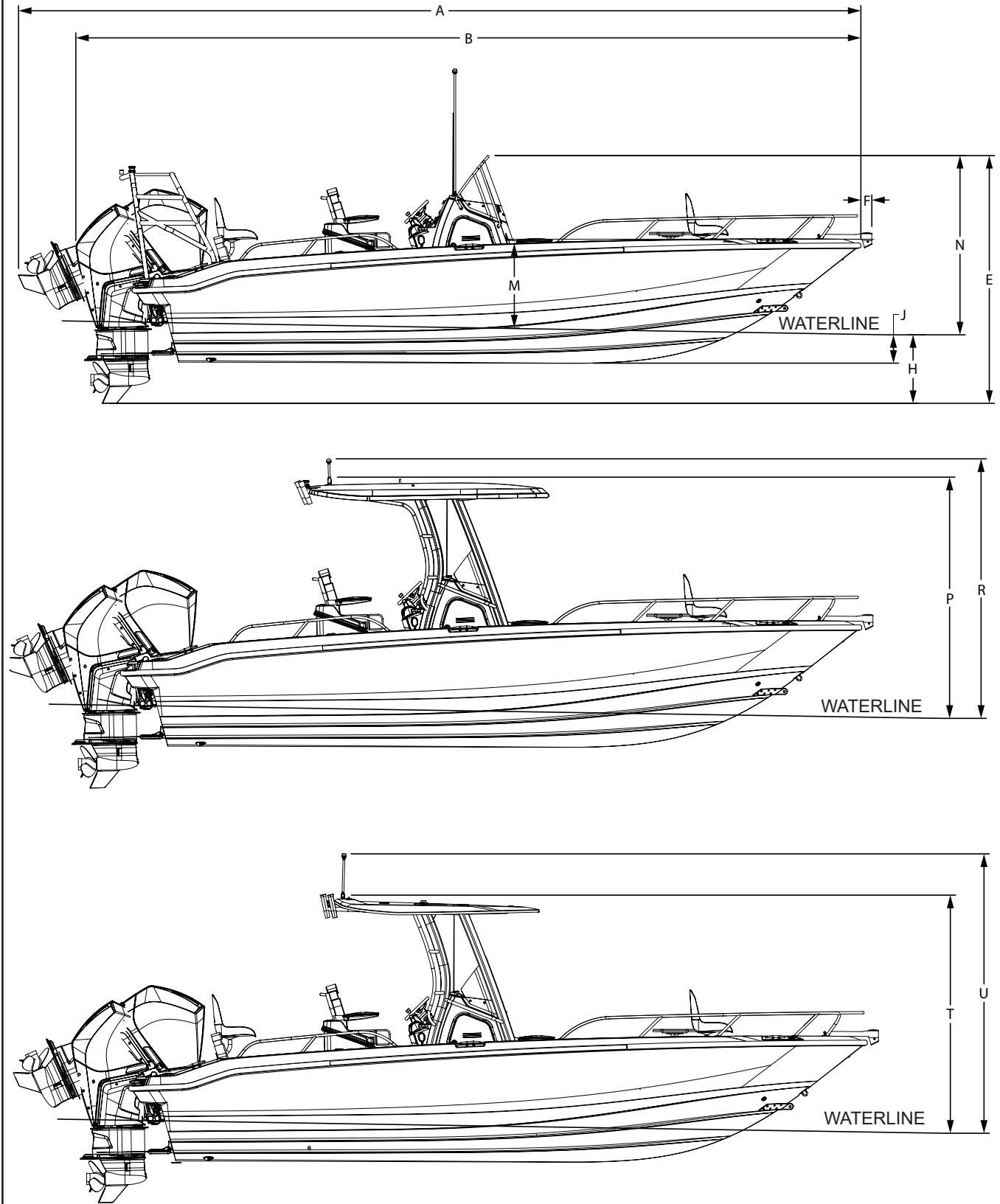

## Deck Occupancy

Figure 2.7.1

### Working deck

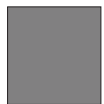

This area is intended for occupation only while mooring, anchoring, loading/unloading or when the boat is at rest.

### Accommodation deck



Movement in this area should be done with extreme caution while the boat is underway. A sudden shift in boat direction can cause a loss of balance and lead to injury or death.

### Stay off



Do not stand or walk in this area. Serious injury could result. If necessary, stand or walk only where non-skid is applied.

### Custom Working Deck

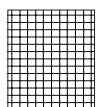

When stern seats are in the stowed position this area is intended for occupation only while mooring, anchoring, or when the boat is at rest.

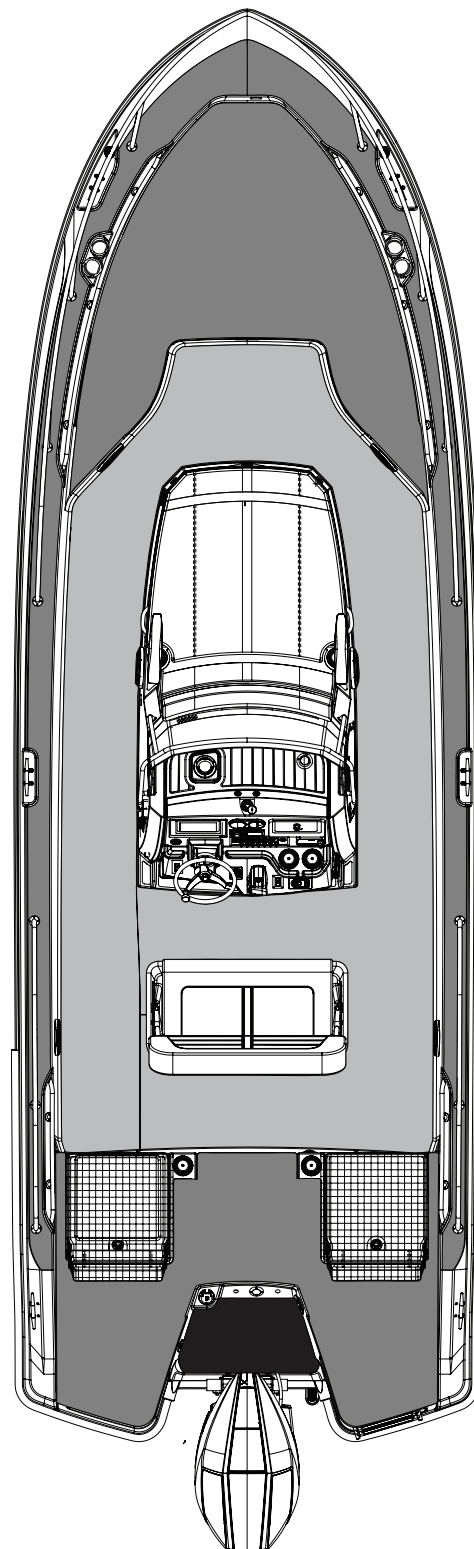

## DANGER

Be aware of your footing while the boat is underway, slipping or falling could result in serious injury or death, especially if the boat is in motion or in rough seas. Keep the accommodation deck clean, so if movement is necessary it will be free of obstruction.

## WARNING

- Gelcoat surfaces are slippery when wet. Use extreme caution when walking on wet surfaces.
- Never occupy the working decks while the boat is underway.
- Use care when waxing to ensure that walkways are not made slippery.



Seating  
Figure 2.8.1

**WARNING**  
Never allow passengers to ride in an area ( bow, gunwales, transom, etc.) that poses a hazard to themselves or the boat.

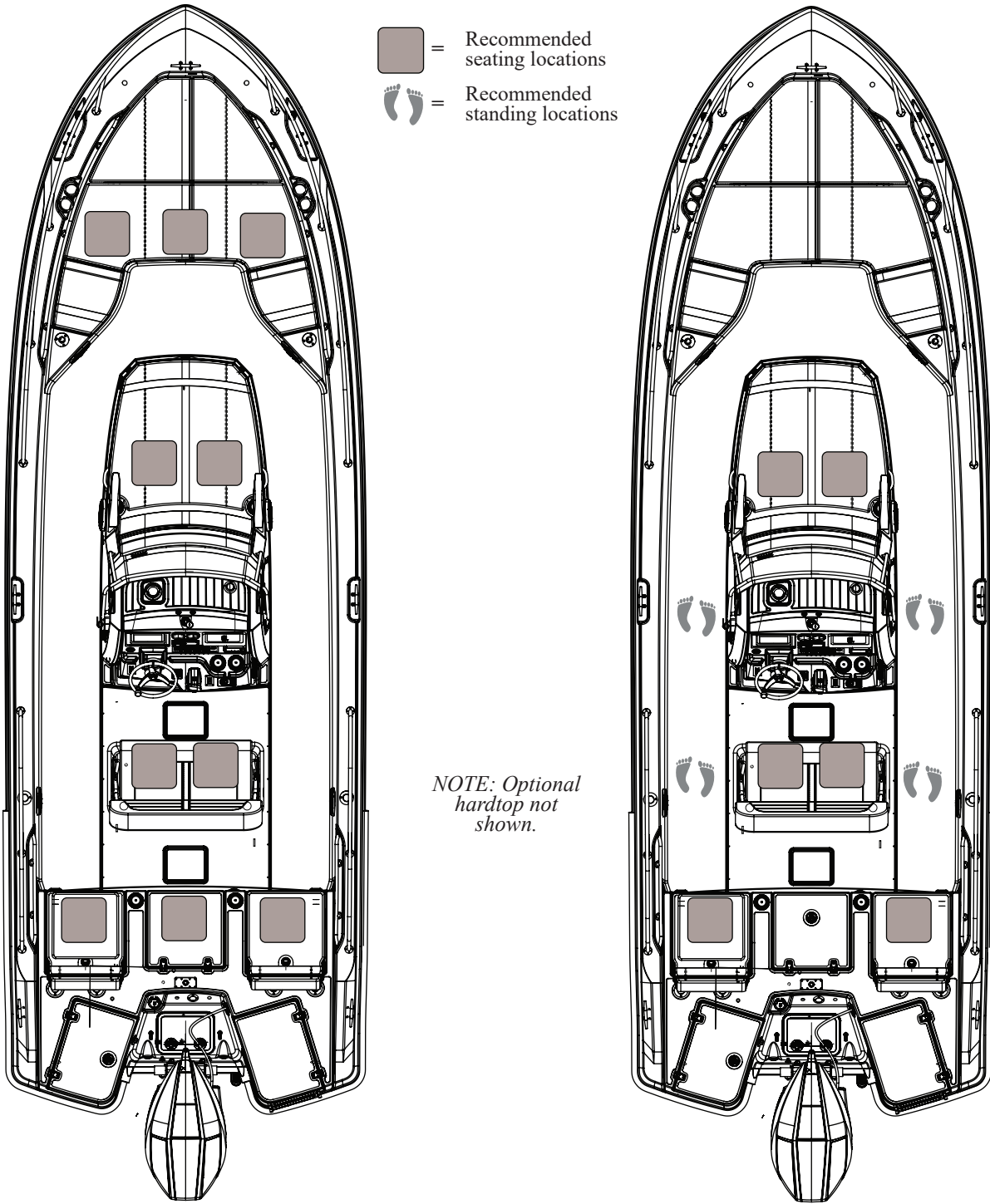

Recommended occupant locations while moored, at idle or under 5 mph

Recommended occupant locations on-plane

Navigation Lighting  
Figure 2.9.1

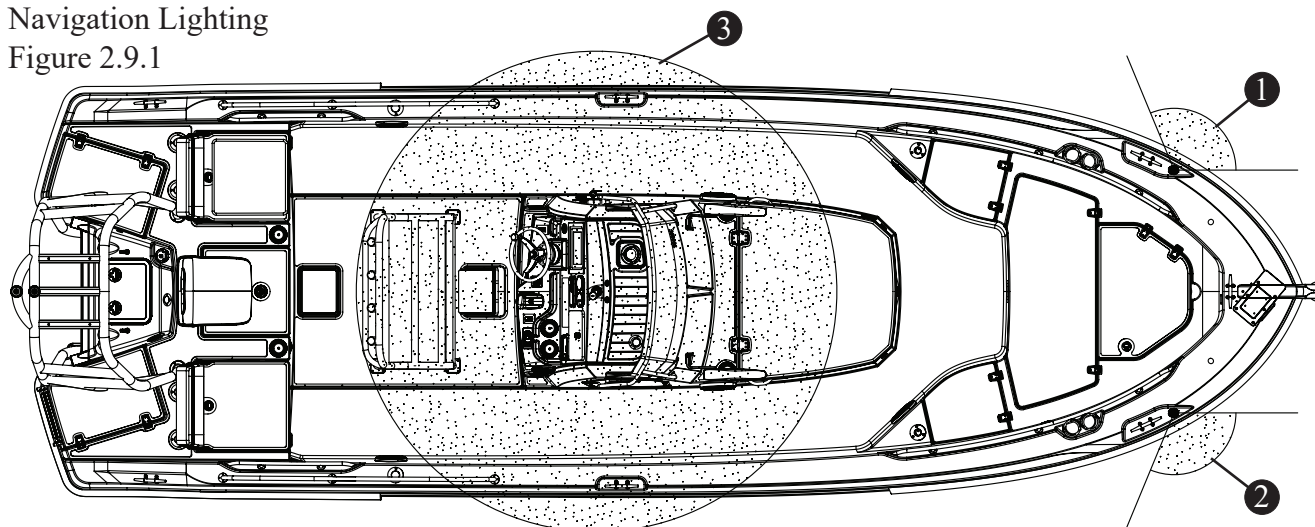

NO HARDTOP (STANDARD)

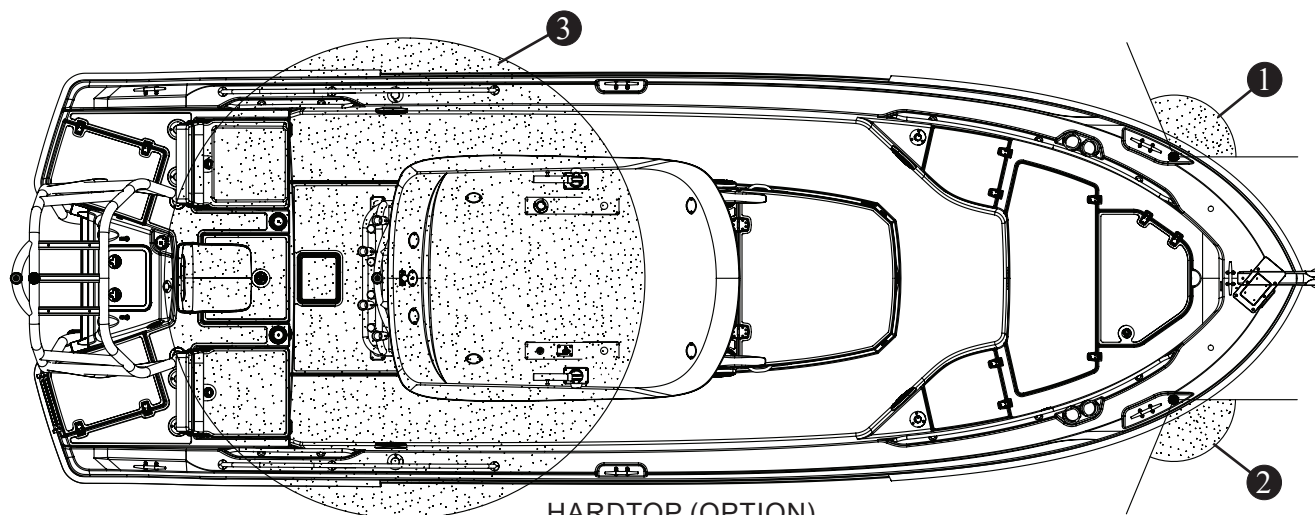

HARDTOP (OPTION)

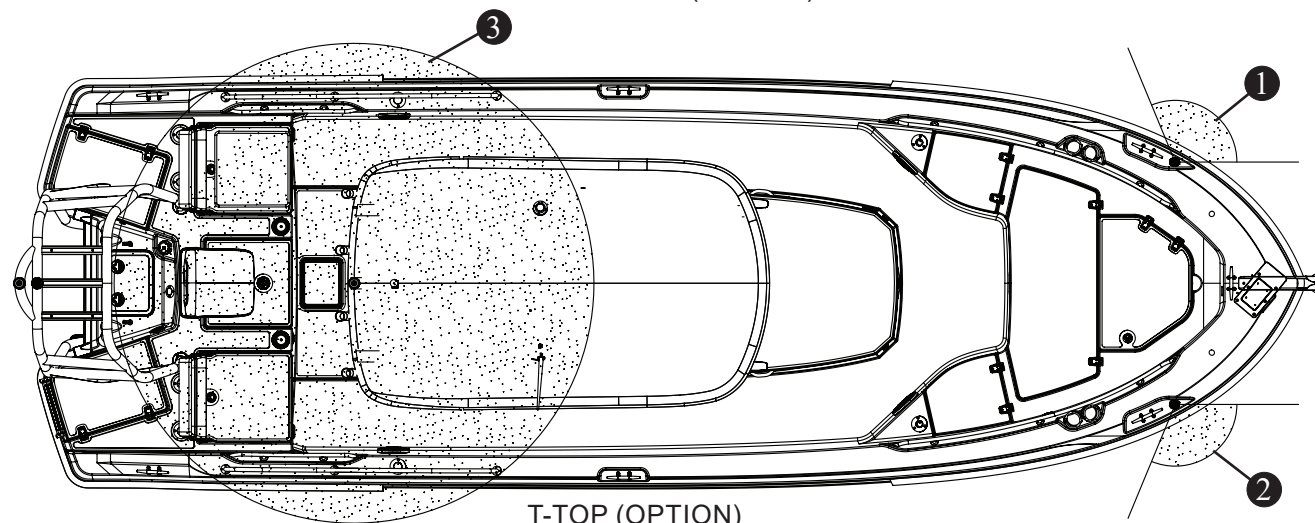

T-TOP (OPTION)

- 1 112.5° PORT NAVIGATION SIDELIGHT (RED) VISIBLE 1 NM
- 2 112.5° STARBOARD NAVIGATION SIDELIGHT (GREEN) VISIBLE 1 NM
- 3 360° ALL-ROUND LIGHT (WHITE) VISIBLE 2 NM

### Location of Thru-hull Fittings

Thru-hull Fittings  
Figure 2.10.1



- 1 BOW LOCKER DRAIN
- 2 ANCHOR LOCKER DRAIN
- 3 RAW WATER PICKUP
- 4 LIVEWELL DRAIN
- 5 LIVEWELL DRAIN (OPTION)
- 6 DECK DRAIN
- 7 BILGE PUMP DISCHARGE
- 8 GARBOARD DRAIN
- 9 RAW WATER PICKUP (OPTION)
- 10 BILGE PUMP DISCHARGE (CE OPTION)

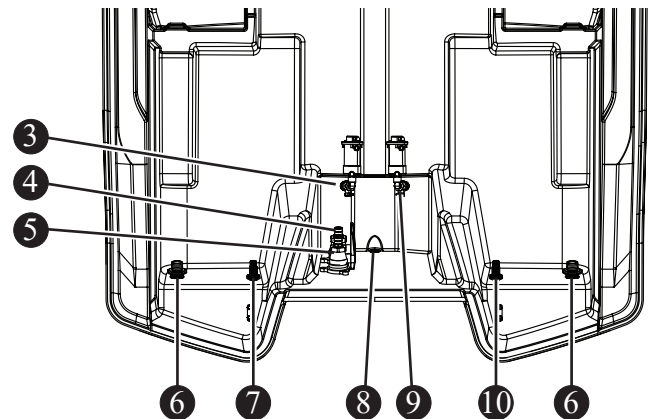

### NOTICE

- The deck drain provides self bailing capabilities while boat is static in the water and no passengers. This feature prevents accumulation of water in the cockpit.
- Depending on the boat type, underwater fittings may require drain plugs. Garboard and fishbox drain plugs must be in place before boat enters the water. Any submerged fitting must be plugged or seacock needs to be closed.
- Check thru-hull fittings and deck drain scupper flaps annually for proper seal. When boat enters the water, check fittings for dripping. Clean, remove, and reseal underwater fittings biannually.
- If thru-hull fittings need replacing, visit an authorized Boston Whaler dealer. Thru-hull fittings that are improperly installed can cause premature hull failure and may void the Boston Whaler limited warranty.
- A standard 1" Snap-tite plug can be used to replace the drain plug(s) in this vessel. Always carry spare plugs to be used in the event that the drain plug(s) become lost or damaged.

## Features

### Deck

Figure 2.11.1

- 1 CLEAT
- 2 NAVIGATION SIDELIGHT (2)
- 3 HIGH BOW RAIL (OPTION)
- 4 FORWARD GRAB RAIL
- 5 BOW TABLE (OPTION)
- 6 ROD HOLDER
- 7 CONSOLE LOUNGE
- 8 PHONE CHARGING PAD
- 9 COMPASS
- 10 HELM
- 11 HELM SEAT
- 12 LOW PROFILE SIDE RAILS
- 13 AFT GRAB RAIL
- 14 STERN SEAT
- 15 AFT PEDESTAL FISHING SEAT (OPTION)
- 16 FUEL FILL
- 17 HOUSE BATTERY AND SWITCH HATCH
- 18 TOW ARCH (OPTION)
- 19 BOW SHADE SOCKET (2)
- 20 BOW LOUNGE & ANCHOR LOCKER ACCESS
- 21 BOW LOUNGE & STORAGE LOCKER ACCESS
- 22 GRAB RAIL (2)
- 23 CONSOLE/HEAD DOOR
- 24 SATELLITE RADIO ANTENNA (OPTION)
- 25 GRAB RAIL (2)
- 26 FUEL TANK INSPECTION PLATE
- 27 LIVEWELL
- 28 FIRE PORT (CE OPTION)
- 29 BILGE PUMP HATCH
- 30 REBOARDING LADDER & ENGINE BATTERY
- 31 JACK PLATE (OPTION)
- 32 RAW WATER WASHDOWN (OPTION)

OPTIONAL ITEMS NOT SHOWN: TROLLING MOTOR, ANCHOR ROLLER, FORWARD PEDESTAL FISHING SEAT AND ALL ACTIVITY TOWER.

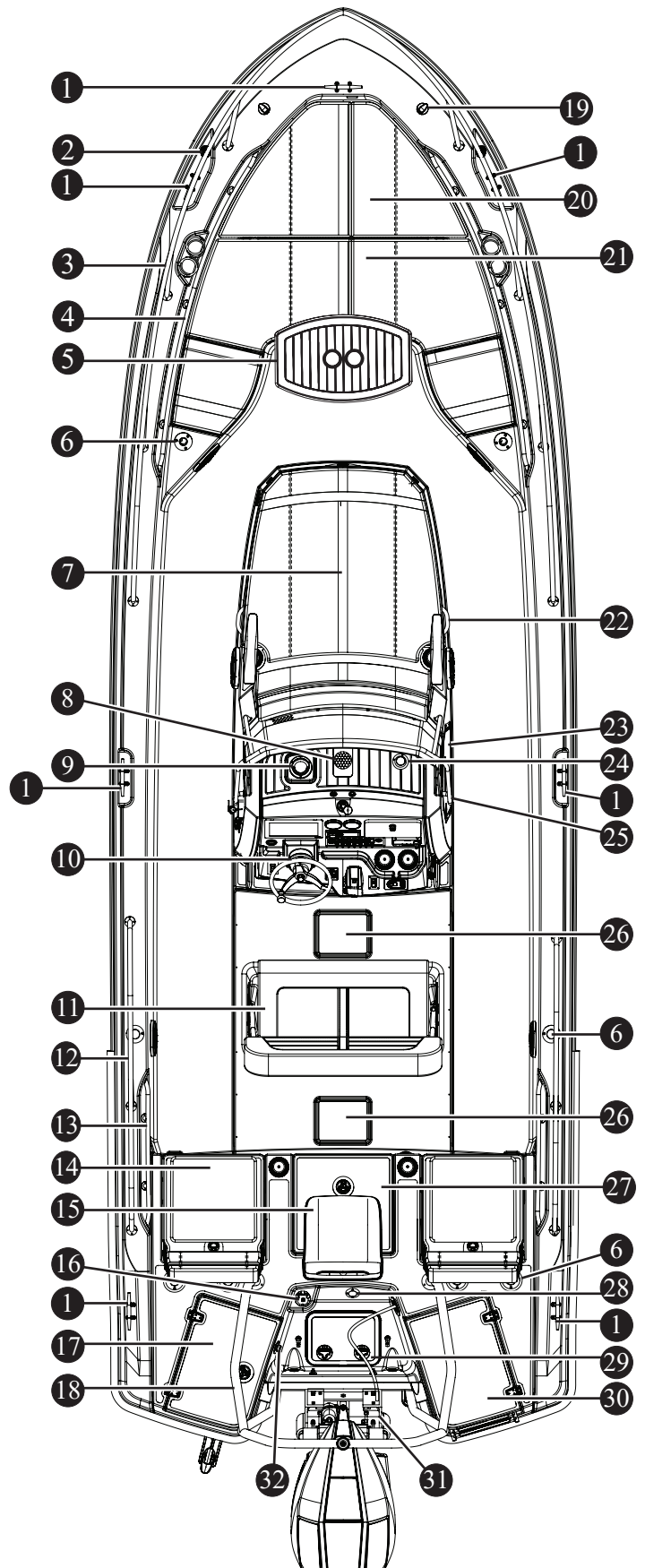

## Features

Lounge and Console Area  
Figure 2.12.1

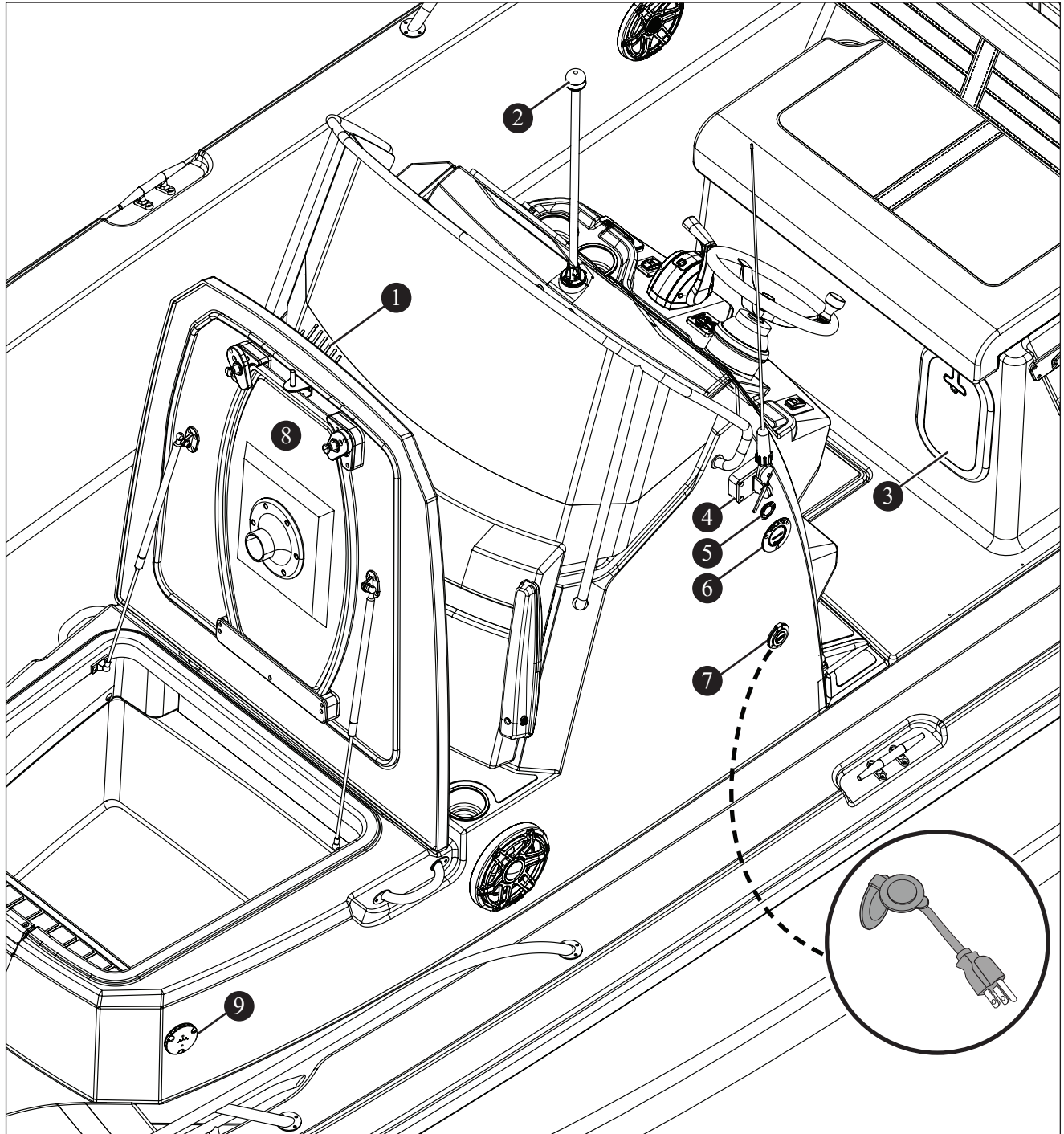

- |                                  |                                 |
|----------------------------------|---------------------------------|
| 1 HORN                           | 6 WASTE PUMPOUT (OPTION)        |
| 2 ANCHOR LIGHT                   | 7 BATTERY CHARGER CORD (OPTION) |
| 3 LIVEWELL PLUMBING ACCESS PLATE | 8 COCKPIT TABLE (OPTION)        |
| 4 VHF RADIO ANTENNA (OPTION)     | 9 FRESHWATER FILL (OPTION)      |
| 5 WASTE VENT (OPTION)            |                                 |

### Features

Helm

Figure 2.13.1

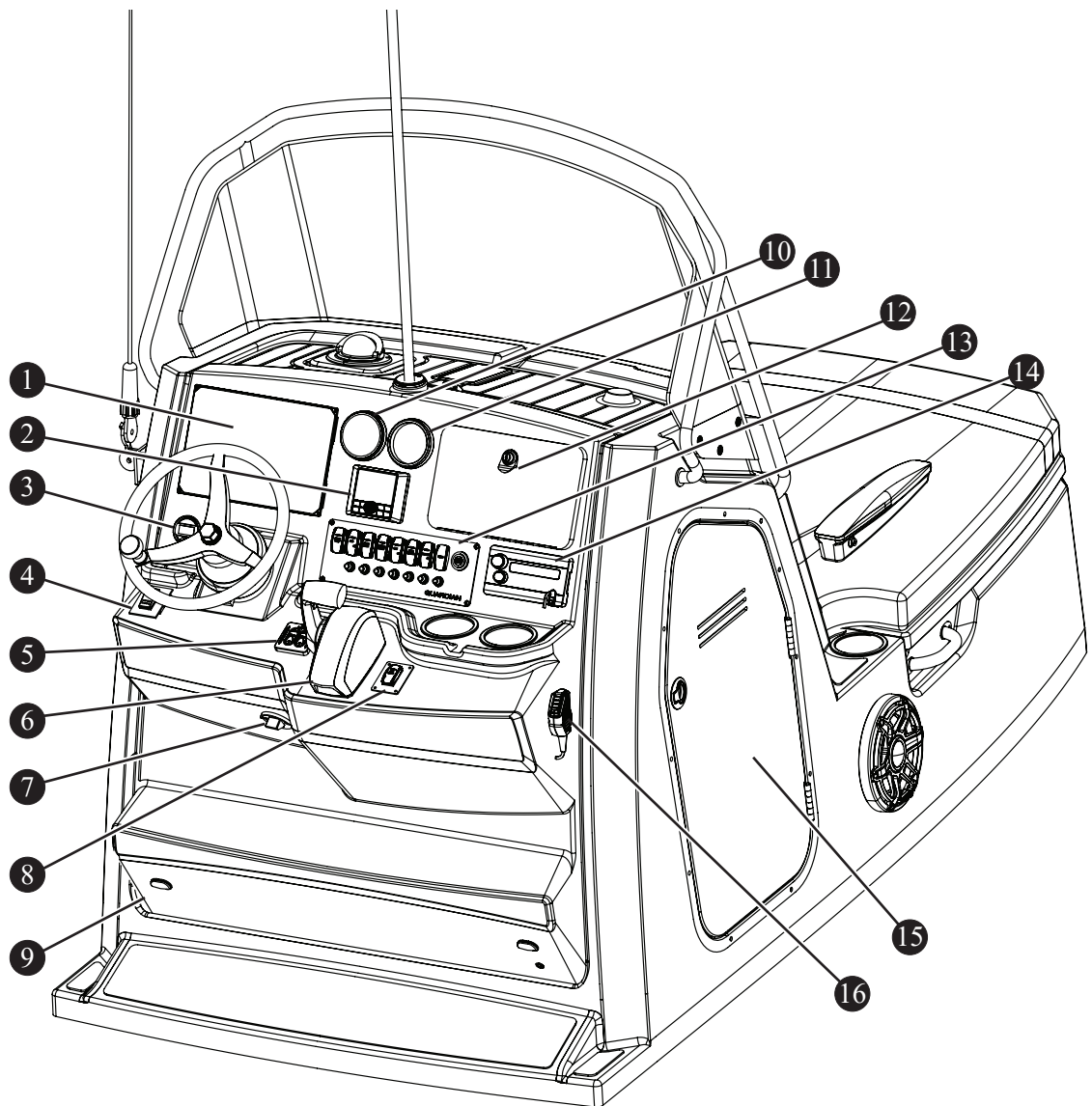

- |   |                               |
|---|-------------------------------|
| 1 HELM DISPLAY (OPTION)                   | 9 COURTESY LIGHT              |
| 2 STEREO (OPTION)                         | 10 SPEEDOMETER                |
| 3 JACK PLATE GAUGE (OPTION)               | 11 TACHOMETER                 |
| 4 JACK PLATE SWITCH (OPTION)              | 12 LOCKABLE CONSOLE STORAGE   |
| 5 TRIM TAB SWITCH (OPTION)                | 13 HELM SWITCH PANEL          |
| 6 THROTTLE AND GEAR CONTROL               | 14 VHF RADIO                  |
| 7 ENGINE EMERGENCY STOP SWITCH            | 15 HEAD & CONSOLE STORAGE     |
| 8 AUXILIARY BILGE PUMP SWITCH (CE OPTION) | 16 VHF RADIO HANDSET (OPTION) |

Helm Switches  
Figure 2.14.1

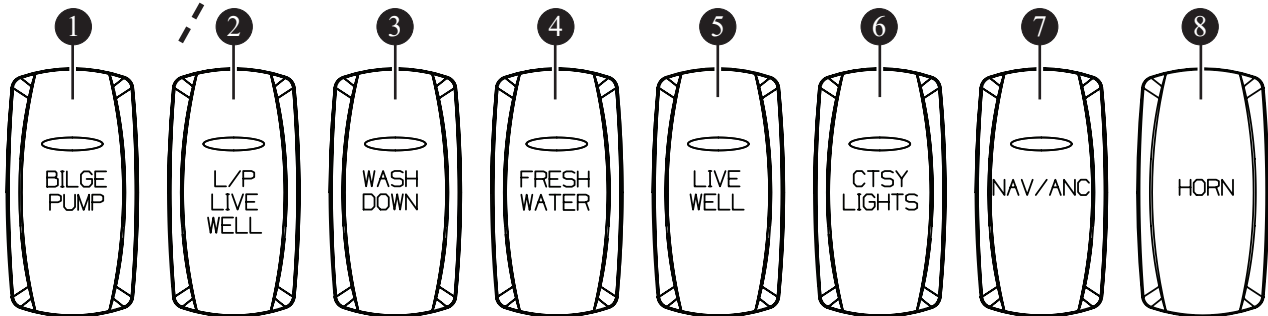
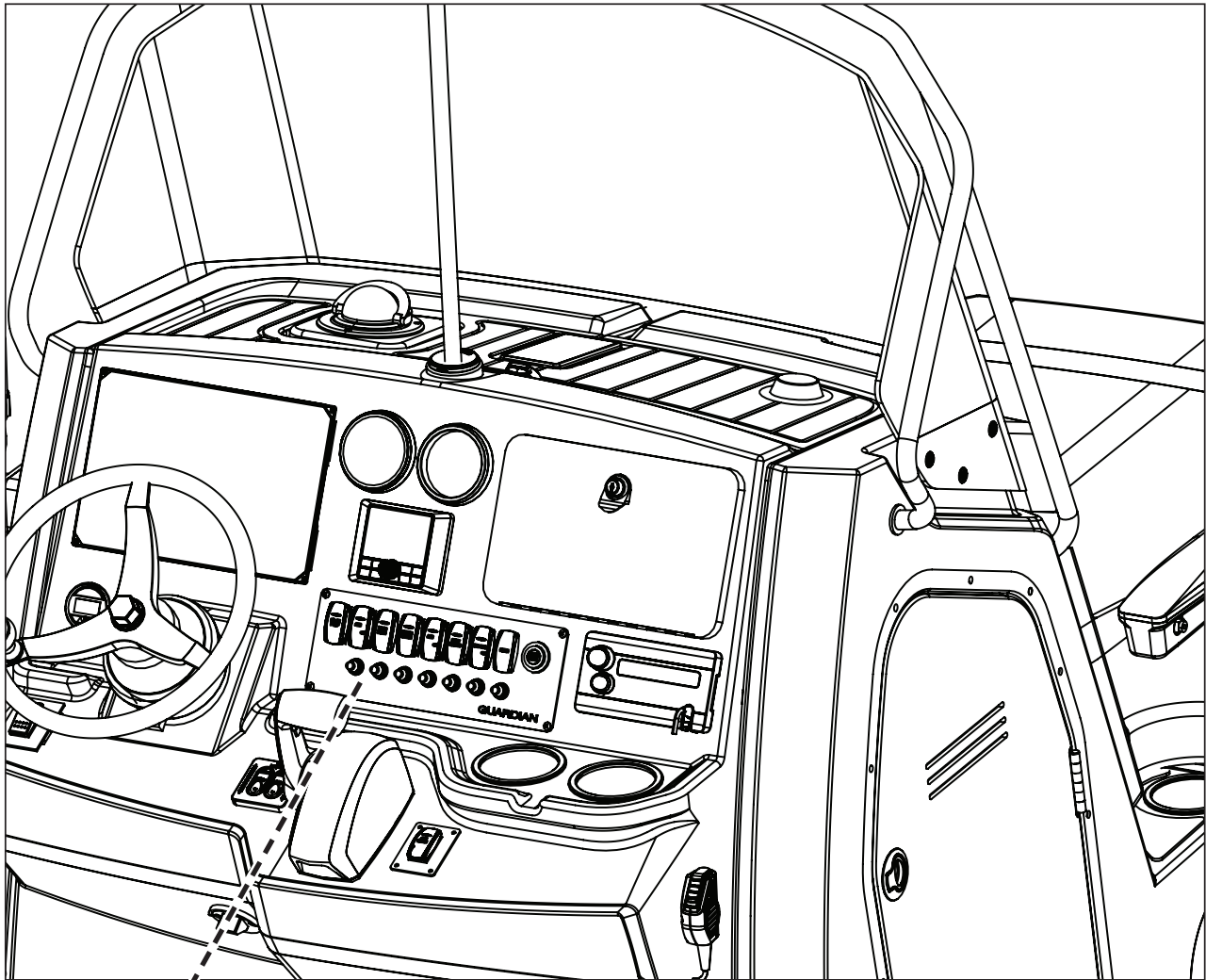

- |  |                                |
|--|--------------------------------|
| 1 BILGE PUMP                           | 5 LIVELWELL PUMP               |
| 2 LEANING POST LIVELWELL PUMP (OPTION) | 6 COURTESY LIGHTS              |
| 3 RAW WATER WASHDOWN                   | 7 NAVIGATION AND ANCHOR LIGHTS |
| 4 FRESHWATER SHOWER                    | 8 HORN                         |

### Features

#### Console Storage

The head and console storage area can be used to store boat fenders or personal flotation devices (see Figure 2.15.1).

Head and Console Storage  
Figure 2.15.1

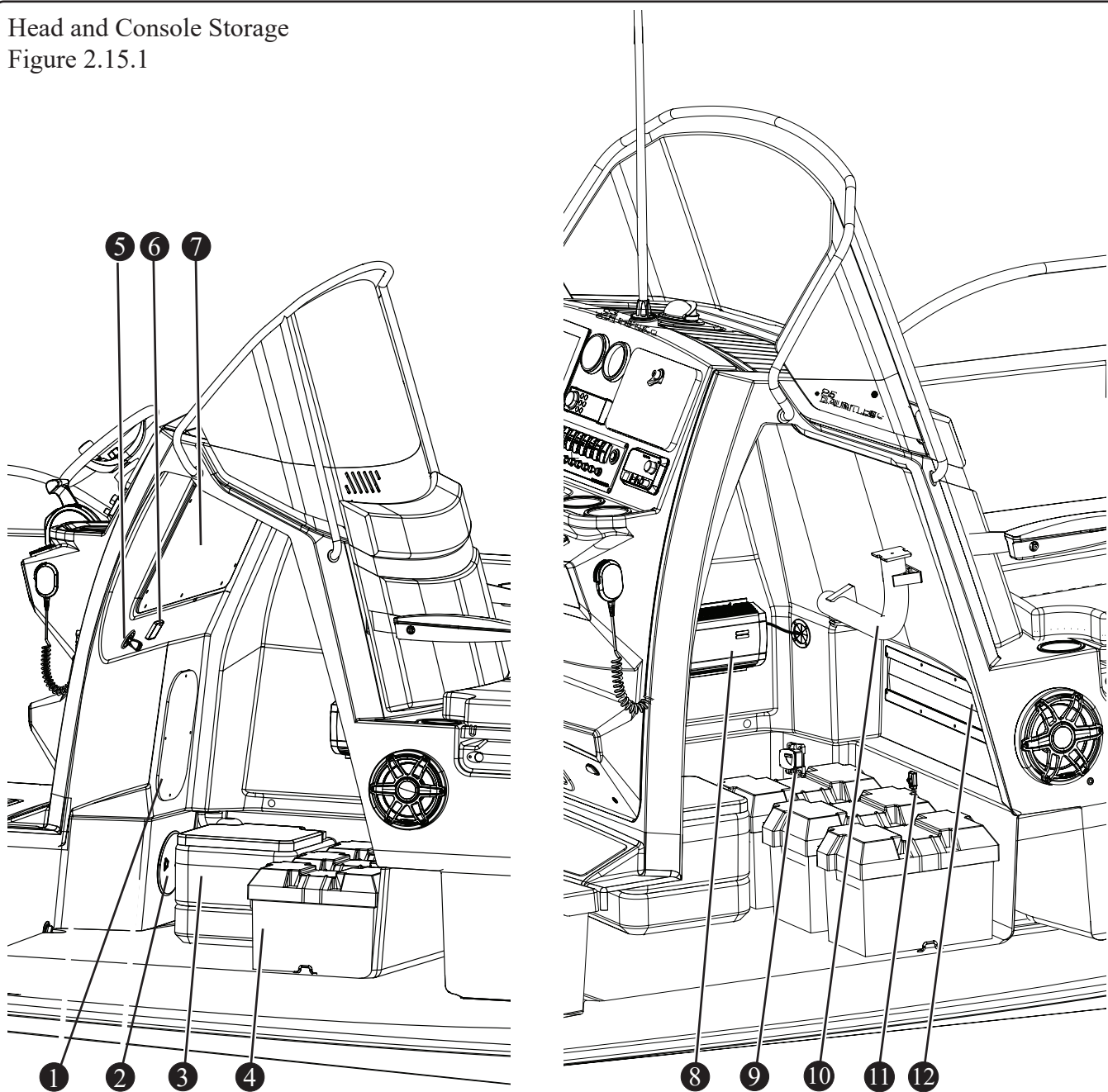

1 ACCESS PANEL

2 ACCESS PLATE

3 PORTABLE HEAD

4 TROLLING MOTOR BATTERY (OPTION)

5 IGNITION SWITCH

6 CARD READER (OPTION)

7 FUSE BLOCK ACCESS PANEL

8 BATTERY CHARGER (OPTION)

9 CIRCUIT BREAKER (TROLLING MOTOR OPTION)

10 COCKPIT TABLE POST (OPTION)

11 12V OUTLET (TROLLING MOTOR OPTION)

12 FISHING ROD HOLDER



## T-Top (Option)

Figure 2.16.1

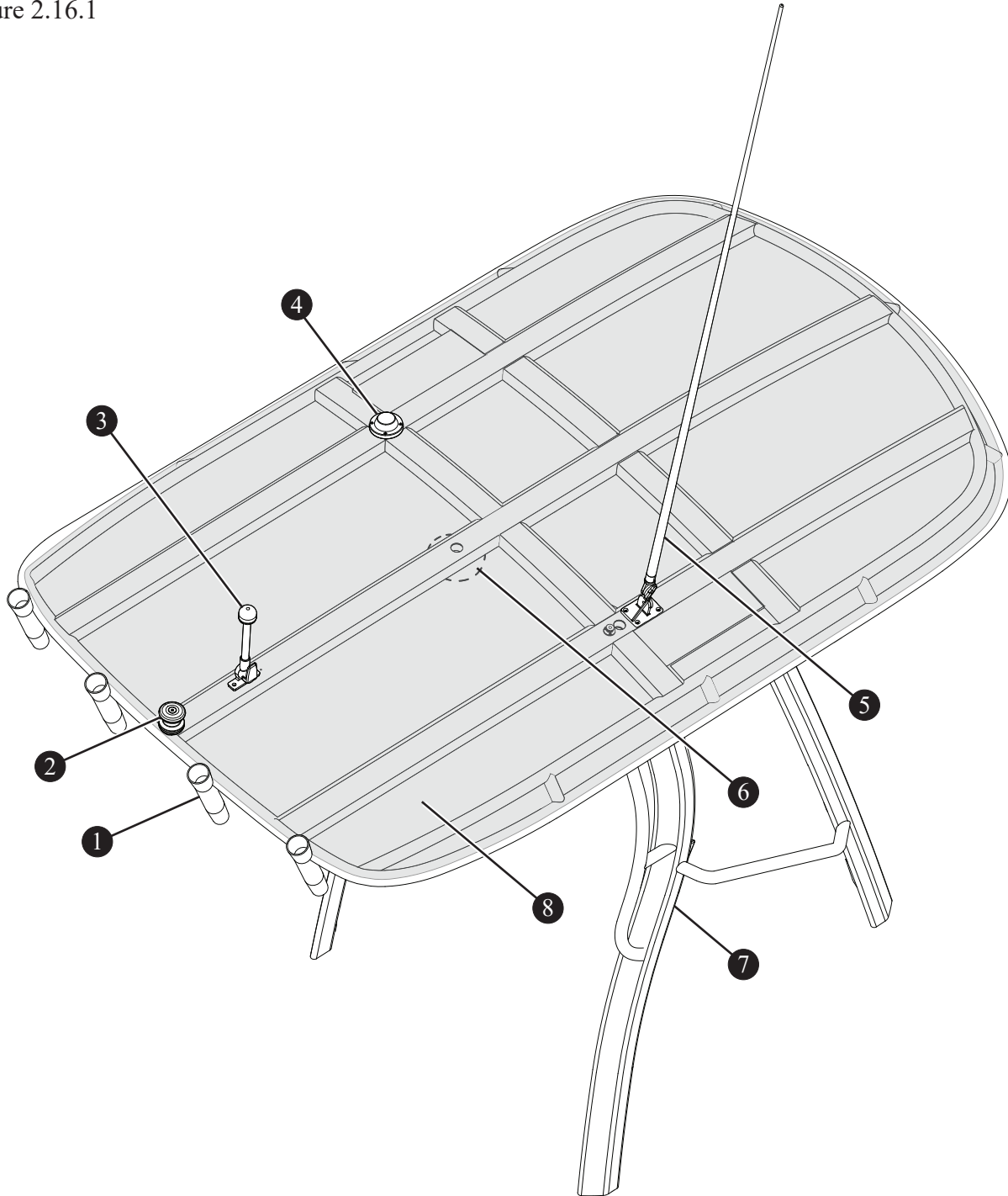

- |                                    |                              |
|------------------------------------|------------------------------|
| 1 ROD HOLDER                       | 5 VHF RADIO ANTENNA (OPTION) |
| 2 WATERSPORTS TOW POINT            | 6 DOME LIGHT (UNDERSIDE)     |
| 3 ALL-ROUND (ANCHOR) LIGHT         | 7 T-TOP FRAME                |
| 4 SATELLITE RADIO ANTENNA (OPTION) | 8 CANVAS                     |

## Hardtop (Option)

Figure 2.17.1

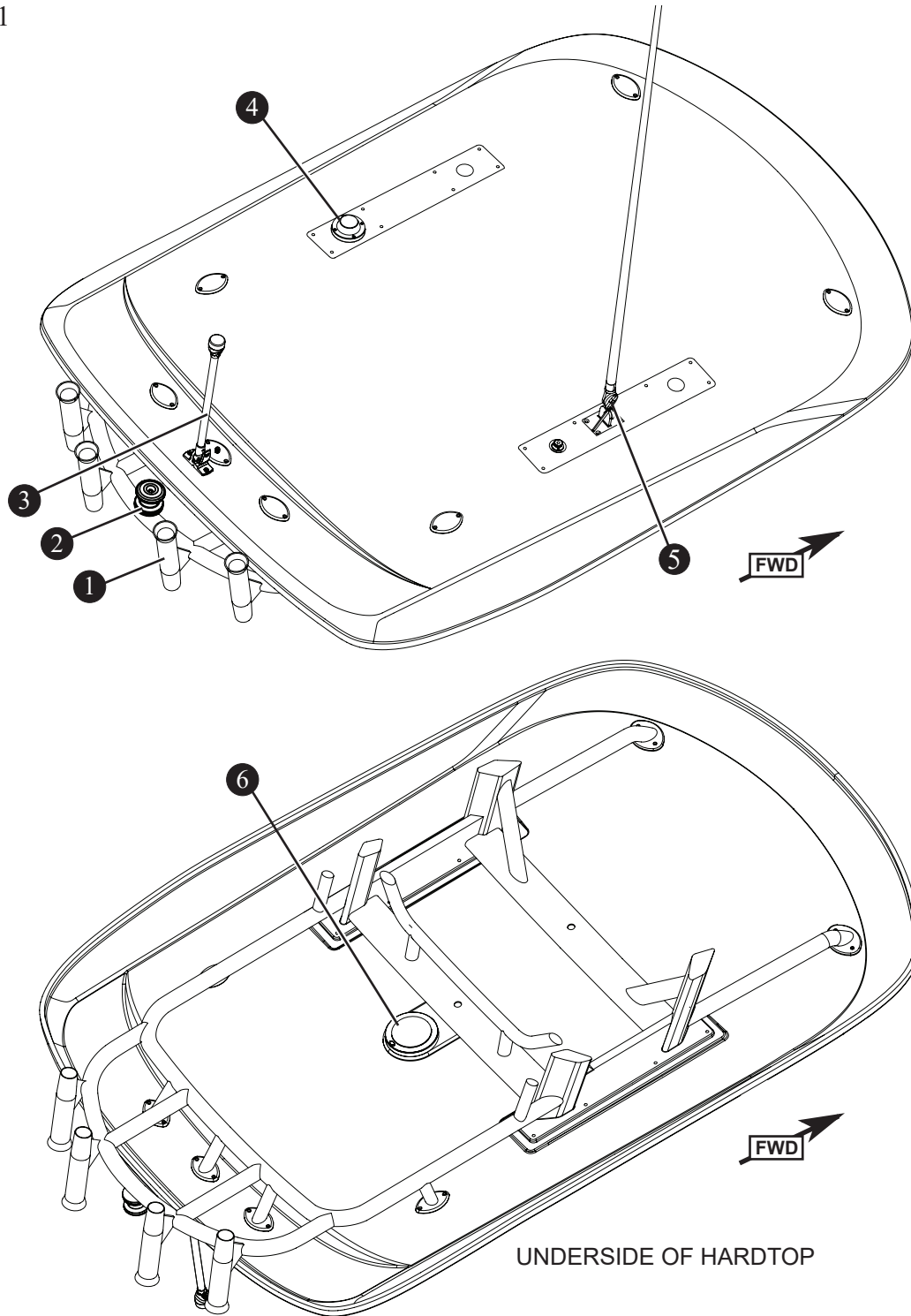

- 1 ROD HOLDER
- 2 WATERSPORTS TOW POINT
- 3 ALL-ROUND (ANCHOR) LIGHT

- 4 SATELLITE RADIO ANTENNA (OPTION)
- 5 VHF ANTENNA (OPTION)
- 6 DOME LIGHT

### Deluxe Leaning Post (Option)

If equipped, the leaning post allows the operator to stand and navigate the vessel.

Figure 2.18.1

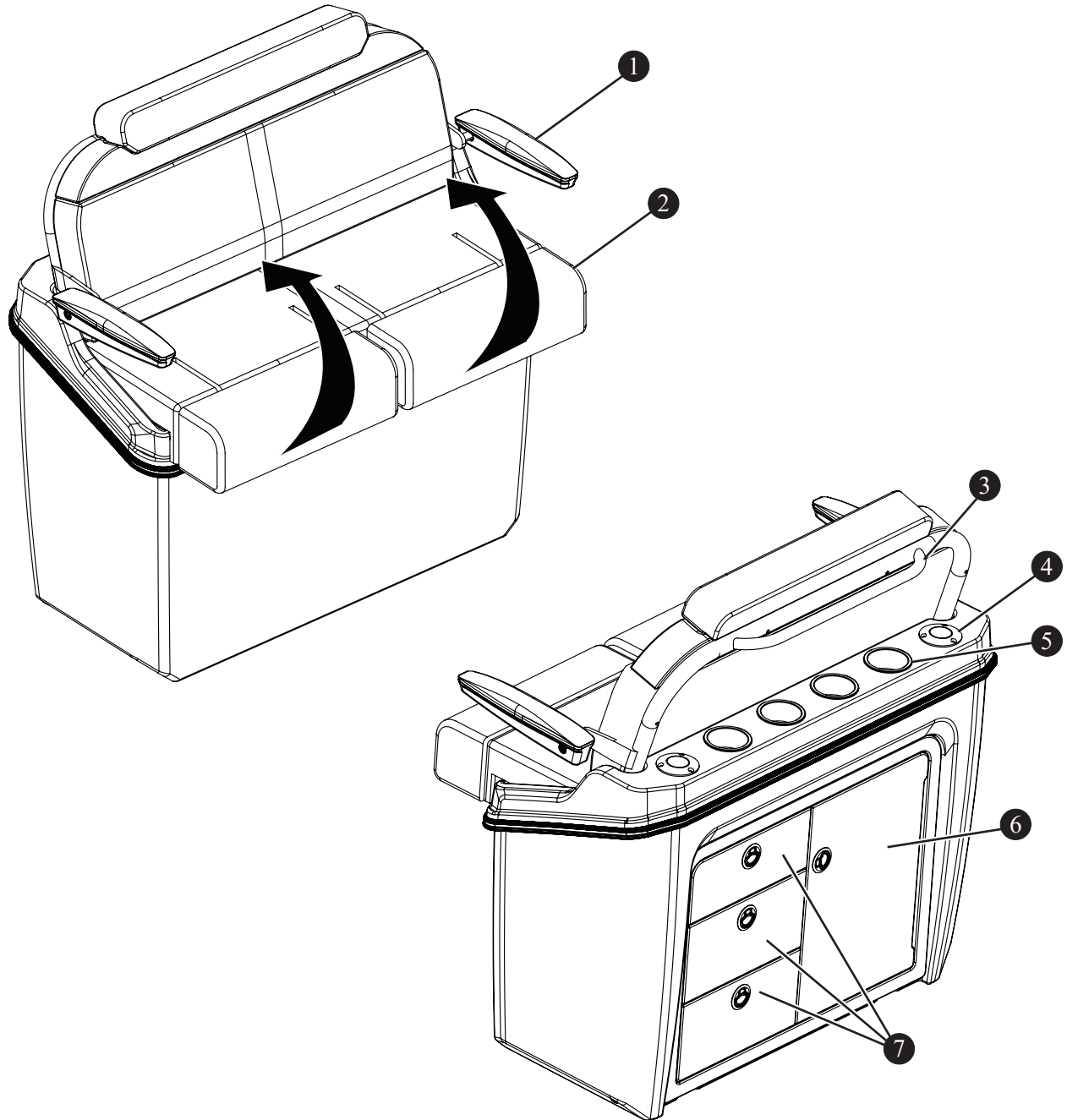

- 1 FOLDING ARMREST
- 2 FOLDING BOLSTER SEATS
- 3 GRAB RAIL
- 4 ROD HOLDERS

- 5 CUP HOLDERS
- 6 STORAGE CABINET
- 7 STORAGE DRAWERS

### Competition Leaning Post (Option)

If equipped, the leaning post allows the operator to stand and navigate the vessel.

Figure 2.19.1

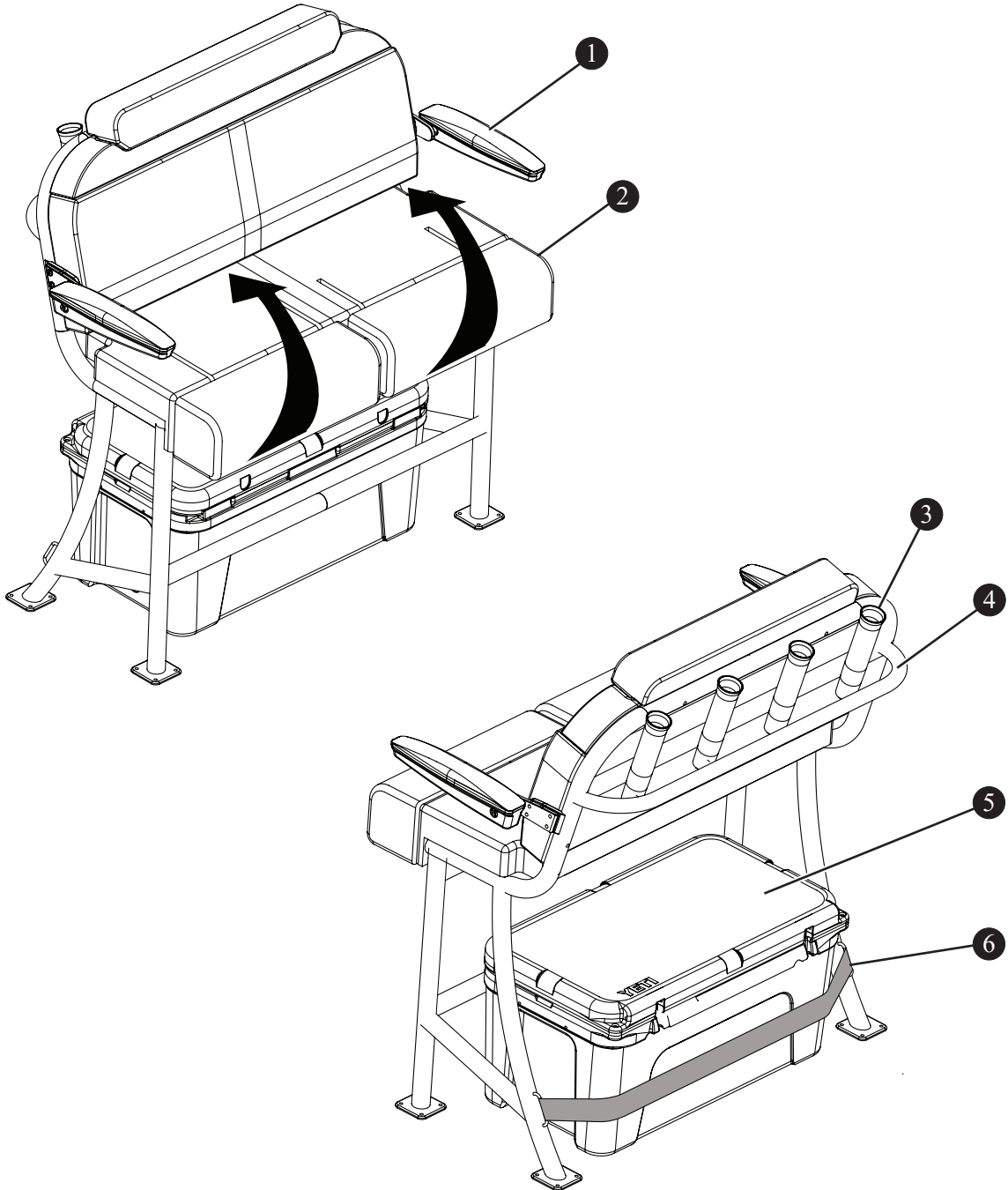

- 1 FOLDING ARMREST
- 2 FOLDING BOLSTER SEATS
- 3 ROD HOLDERS

- 4 GRAB RAIL
- 5 75 QUART COOLER
- 6 COOLER STORAGE STRAP

## Canvas (Option)

Figure 2.20.1

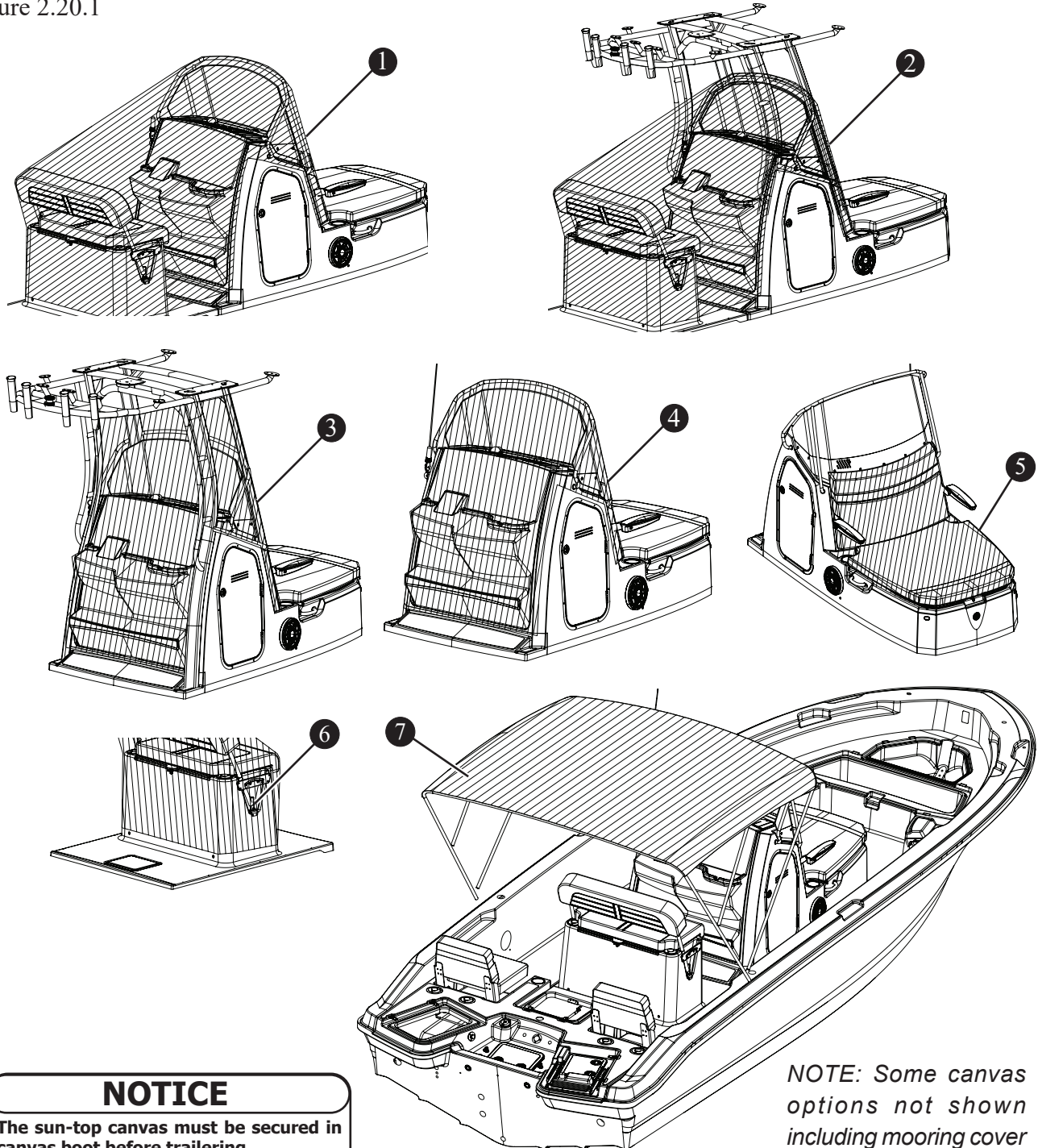

### NOTICE

The sun-top canvas must be secured in canvas boot before trailering.

Never trailer the canvas top in the open position.

*NOTE: Some canvas options not shown including mooring cover and several optional seating covers.*

- |  |                             |
|--|-----------------------------|
| 1 HELM SEAT AND CONSOLE COVER              | 5 CONSOLE LOUNGE SEAT COVER |
| 2 HELM SEAT AND CONSOLE WITH HARDTOP COVER | 6 HELM SEAT COVER           |
| 3 CONSOLE WITH HARDTOP COVER               | 7 SUNTOP WITH STORAGE BOOT  |
| 4 CONSOLE COVER                            |                             |

### Storage

Storage  
Figure 2.21.1

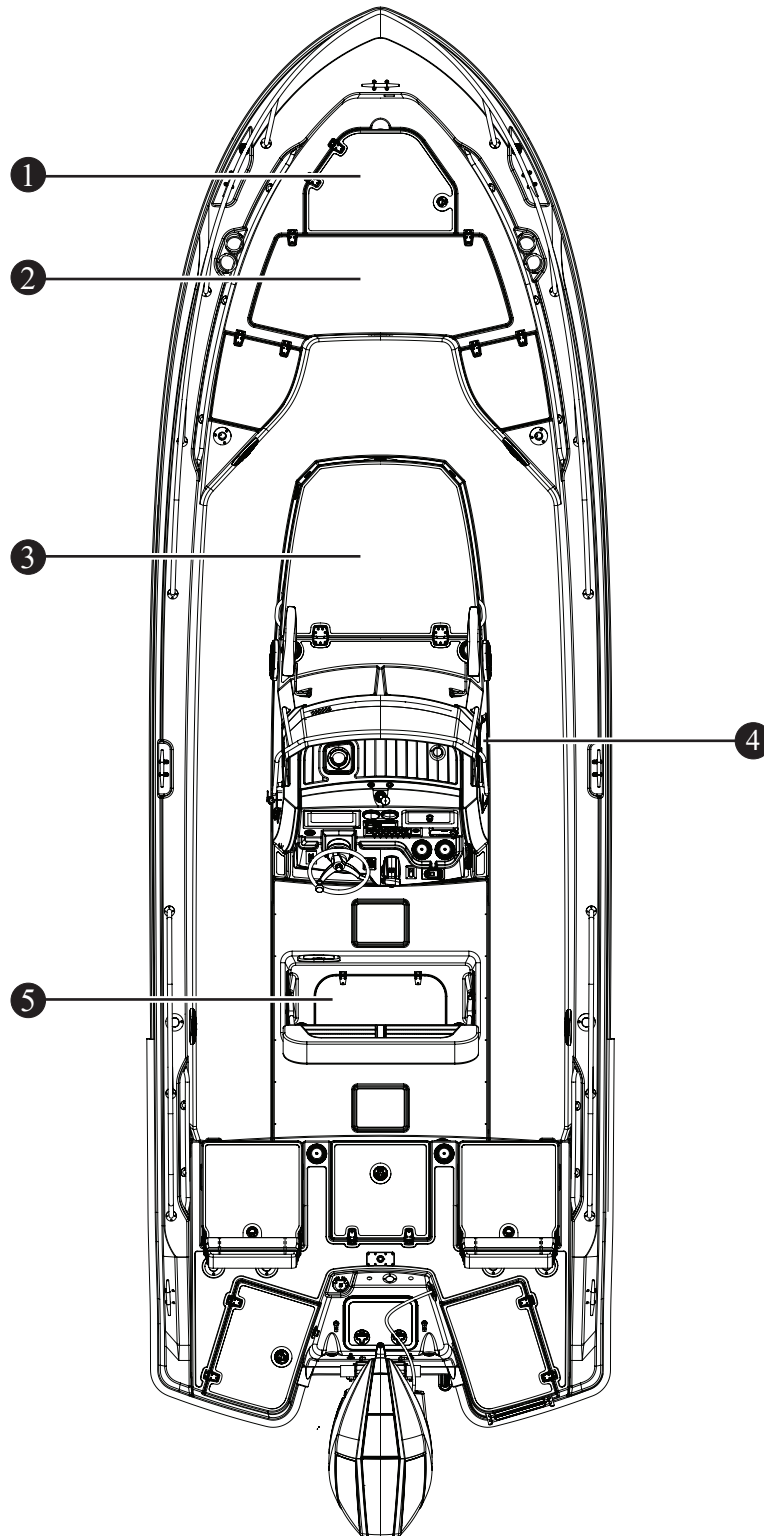

- |                              |                     |
|------------------------------|---------------------|
| 1 ANCHOR LOCKER              | 4 CONSOLE STORAGE   |
| 2 BOW STORAGE LOCKER         | 5 HELM SEAT STORAGE |
| 3 CONSOLE LOUNGE SEAT LOCKER |                     |

---

---

THIS PAGE INTENTIONALLY LEFT BLANK

## Boat Start-up

### NOTICE

To prevent damage to water pump or engine overheating, never start or operate engine(s) (even momentarily) without water circulating through cooling water intakes in the gear case.

### ATTENTION

Shift controls into neutral before starting engine. Shift only when engine is at idle. Reversing at high speeds can cause flooding/swamping due to water being pushed over the transom.

### ATTENTION

Wind and sea currents can change how this vessel responds while in motion. Understanding this vessel and its reactions at speed will make boating safer and more enjoyable.

### ATTENTION

Ensure continuous visibility of other boats, swimmers and obstacles during bow-up transition to planing. Adjust engine to an intermediate trim as soon as boat is on plane to avoid possible ejection due to boat spinout. Do not attempt to turn boat when the engine is trimmed extremely down, under or in.

## Pre-start Check

Operator should know boating safety, safe navigation, and boat operating procedures.

## Start-up Procedure

1. Turn on battery switch located in the stern deck port access hatch, see *Chapter 4 Electrical*.
2. Locate ignition switch inside the head and console storage (see Figure 3.1.1).

**OFF** = No power to engine, instrumentation.

**ACC (accessory)** = Power to instrumentation

**ON** = Engine power on

**START** = (disabled)

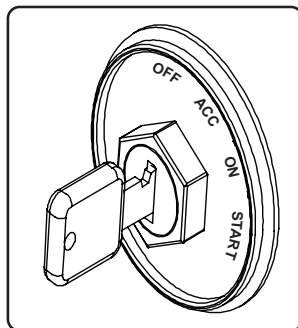

3. Turn the ignition key to the *ON* position and release the key.
4. Ensure *THROTTLE AND SHIFT CONTROL* lever is in the neutral position and the neutral indicator is illuminated (see Figure 3.3.1).
5. Using the engine trim switch (see Figure 3.3.1), ensure lower unit of engine is in the water.
6. Insert one end of safety lanyard into engine emergency stop switch (see Figure 3.2.1) and the opposite end attach to self (operator).
7. Press *START ENGINE STOP* button on throttle and shift control (see Figure 3.3.1). The electronic starting system automatically cranks engine for starting. If engine fails to start, the system stops cranking. Press start/stop button again until engine starts.

Head and Console Storage, Ignition Switch  
Figure 3.1.1

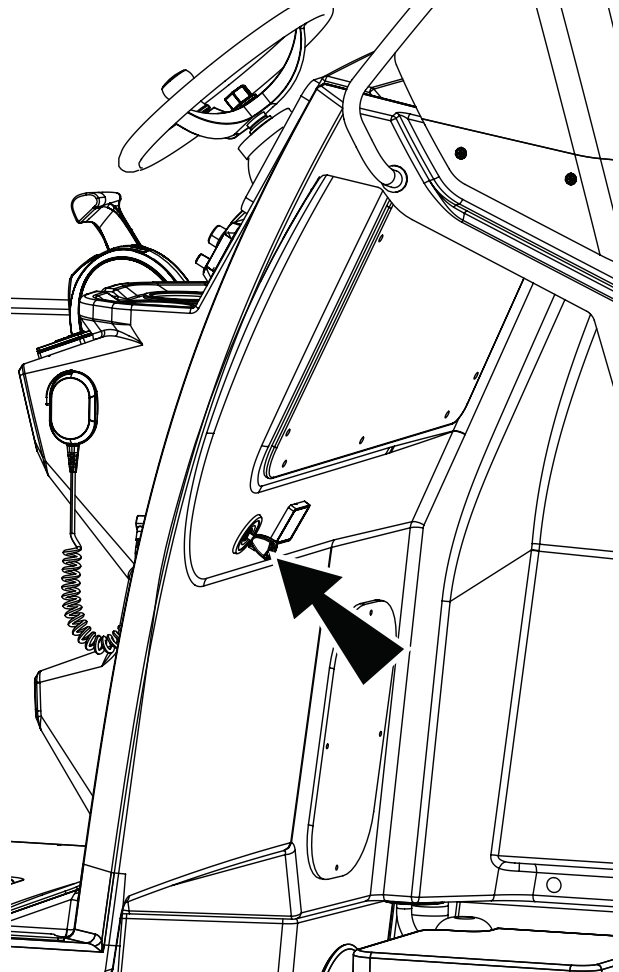



### Engine Warm Up

The *THROTTLE ONLY* button (see Figure 3.3.1) on the throttle and shift control allows the operator to increase engine RPMs for warm-up without being in gear. To operate:

1. Ensure throttle and shift lever is in neutral.
2. Press *THROTTLE ONLY* button.
3. Advance throttle and shift lever to increase engine RPMs to warm engines. RPMs are limited in throttle only mode to prevent engine damage.
4. To disengage, return port throttle and lever back to neutral position.
5. Press *THROTTLE ONLY* button to turn off.

### Boat Shut-down

1. Make sure the boat is securely moored to the dock before shutting down the engine.
2. Move throttle and shift control to the neutral position.
3. Press *START ENGINE STOP* button to stop engines (see Figure 3.3.1).
4. Before leaving vessel be sure turn ignition switch inside head and console storage to the *OFF* position.
5. Turn off battery switch located in the stern deck port access hatch see *Chapter 4 Electrical*.

REFER TO THE ENGINE MANUFACTURER'S MANUAL IN OWNER'S PACKET FOR COMPLETE INSTRUCTIONS AND WARRANTY INFORMATION.

### Engine Trim

The engine trim switch located on the shift control lever (see Figure 3.3.1) raises and lowers the engine to achieve optimum performance while underway. The trim switch is also used for launching, and beaching.

### Active Trim

Active Trim is a GPS, speed-based engine trim system that adjusts engine trim based on changes in boat speed and maneuvers to improve performance, fuel economy, and ease of operation. Active Trim switches, located on the side of the throttle and shift

control, have several selectable trim profiles that allow the operator to compensate for changes in boat load, operator preference, and weather conditions.

REFER TO OWNER'S PACKET FOR COMPLETE INSTRUCTIONS AND WARRANTY INFORMATION.

## NOTICE

**Boats can be operated in a manner and speed resulting in trim angles that cause visibility to be obscured. Motor trim, hull trim plane and speed are factors that affect a boat's trim angle.**

Engine Emergency Stop Switch  
Figure 3.2.1

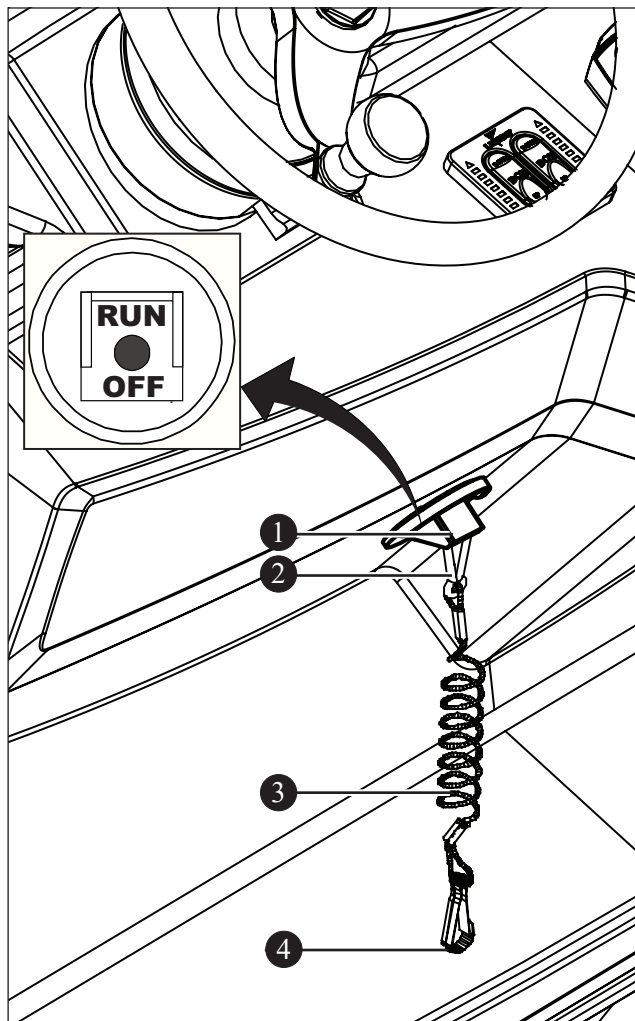

- 1 ENGINE EMERGENCY STOP SWITCH
- 2 HELM SWITCH CLIP
- 3 LANYARD
- 4 OPERATOR CLIP

## Throttle and Shift Control

The throttle and shift control is used to manage both the shifting mechanism and the throttle (see Figure 2.20.1). This control regulates engine RPMs, which controls the speed of the boat. Moving the lever forward shifts the engine into forward gear. Continuing to move the lever forward progressively increases the forward speed of the boat. Moving the lever backwards shifts the engine into reverse gear, and continuing to move the lever back progressively increases the reverse speed of the boat. The lever must be in the neutral position to start the engine. When in neutral, otherwise known as the idle position, the propeller is not engaged. A green neutral indicator light is illuminated atop the throttle and shift lever when in neutral.

Throttle and Shift Control  
Figure 3.3.1

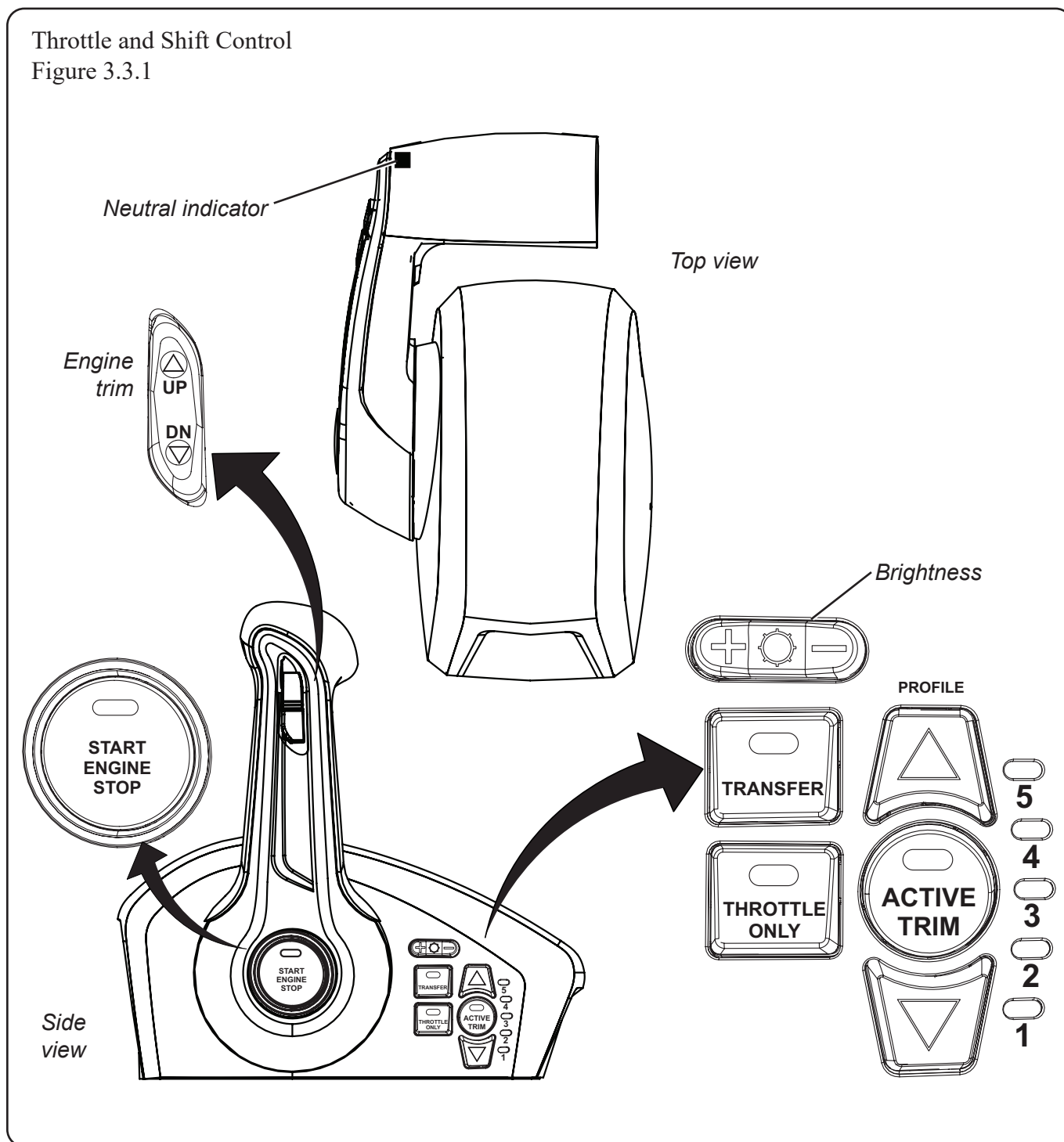

## Buttons and Switches

Basic button/switch use on the throttle and shift control are detailed below (see Figure 3.8.1).

**Neutral Indicator** - Illuminates when engines are in neutral gear position.

**Trim Engine** - Raises and lowers engine.

**Start Engine Stop** - Starts or stops engine.

**Brightness** - Increases and decreases brightness on control unit.

**Transfer** - Transfer boat control to a different helm.

**Throttle Only** - Increase engine RPMs without shifting into gear.

**Active Trim** - Turns the Active Trim feature on or off.

**Profile** - Changes the selected Active Trim profile.

REFER TO ENGINE MANUFACTURER'S MANUAL IN OWNER'S PACKET FOR COMPLETE INSTRUCTIONS AND WARRANTY INFORMATION.

## Gauges

The standard gauge set on the 250 Dauntless includes a Smartcraft tachometer and speedometer multi-gauge system.

By pressing the *MODE* button to change displays, the operator is able to gather important data critical to the safe operation of the boat and boat systems.

## Tachometer

Tachometer information includes:

- Engine break-in time
- Water pressure
- Fuel flow
- Temperature
- Engine battery voltage
- Power trim angle-water pressure
- Power trim angle
- Digital tachometer
- Hour meter

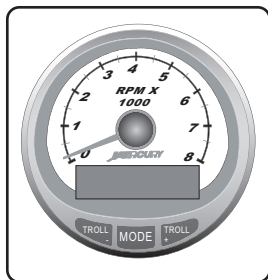

## Speedometer

Speedometer information includes:

- Clock-temperature
- Fuel level
- Oil level
- Traveling range
- Fuel economy
- Trip odometer
- Digital speedometer
- Barometer

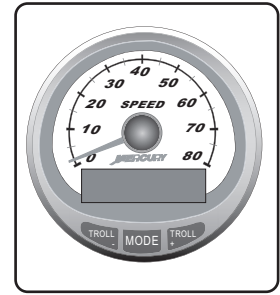

To get the most out of the multi-system display features, read the manual.

## VesselView® (Option)

If equipped, VesselView allows the operator to receive critical operational information, displayed clearly and instantly at the helm display. The system continuously monitors and reports information ranging from basic operating data to detailed vessel environment information.

## System Calibration

Boston Whaler or the dealer has calibrated the VesselView to the boat's equipment. If equipment is added, system must be recalibrated.

FOR RECALIBRATION OR MANUFACTURER INFORMATION REFER TO OWNER'S PACKET. FOR COMPLETE INSTRUCTIONS AND WARRANTY INFORMATION.

## VesselView Mobile

VesselView MOBILE connects the SmartCraft data network to an Apple or android phone. VesselView MOBILE enables SmartCraft to be used on a mobile device with all the digital data the SmartCraft engine supports plus new features such as:

- Maintenance reminders
- Mapping
- Performance summary
- Fault code diagnostics

## Trim Tabs (Option)

### ATTENTION

**Visibility from the helm station may be limited, use of trim tabs may be necessary to maintain adequate visibility in some running conditions. Avoid serious injury or death from collisions. Maintain a lookout as required by USCG Navigation Rules.**

This vessel is equipped with electrically powered trim tabs (see Figure 3.4.2). The trim tab electrical circuit is protected with a 20 Amp fuse located in the fuse block behind the upper access panel inside the console (see Figure 3.4.1). Trim tabs are used to assist in leveling the vessel when there is uneven weight distribution or strong cross winds. The use of trim tabs may also increase operator visibility, particularly during initial acceleration. An untrimmed boat will:

- Reduce fuel economy
- Increase wear on the engine

### Operation

The trim tabs are controlled by rocker switches located on the center part of helm (see Figure 3.4.1). Short momentary bursts of the rockers will achieve proper attitude of the hull. Using the trim tabs will:

- Level the boat; fore and aft, port and starboard.
- Reduce resistance in the steering system.
- Increase speed.
- Reduce strain on the engine.
- Provide a smoother, more stable ride.

Electrically Powered Trim Tabs

Figure 3.5.1

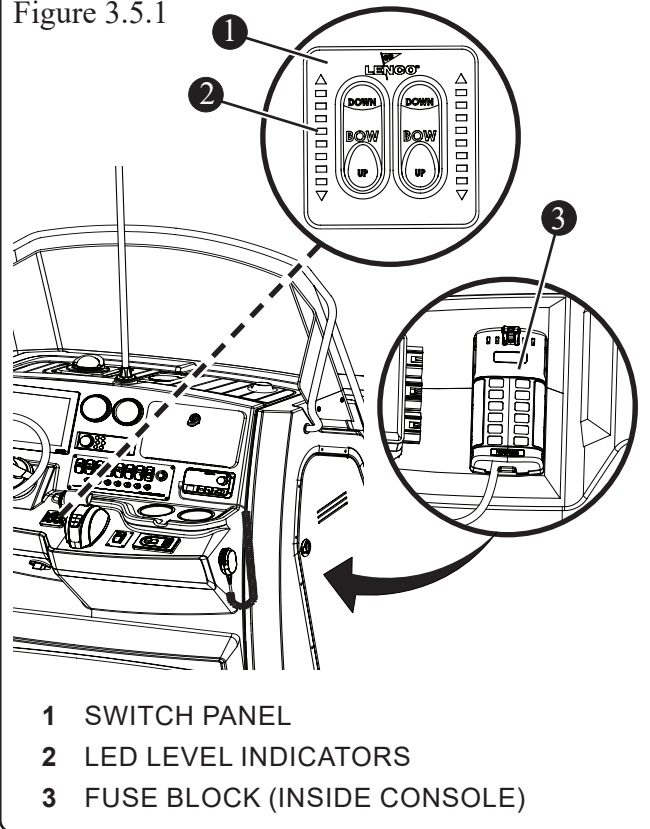

Trim Tabs  
Figure 3.5.2

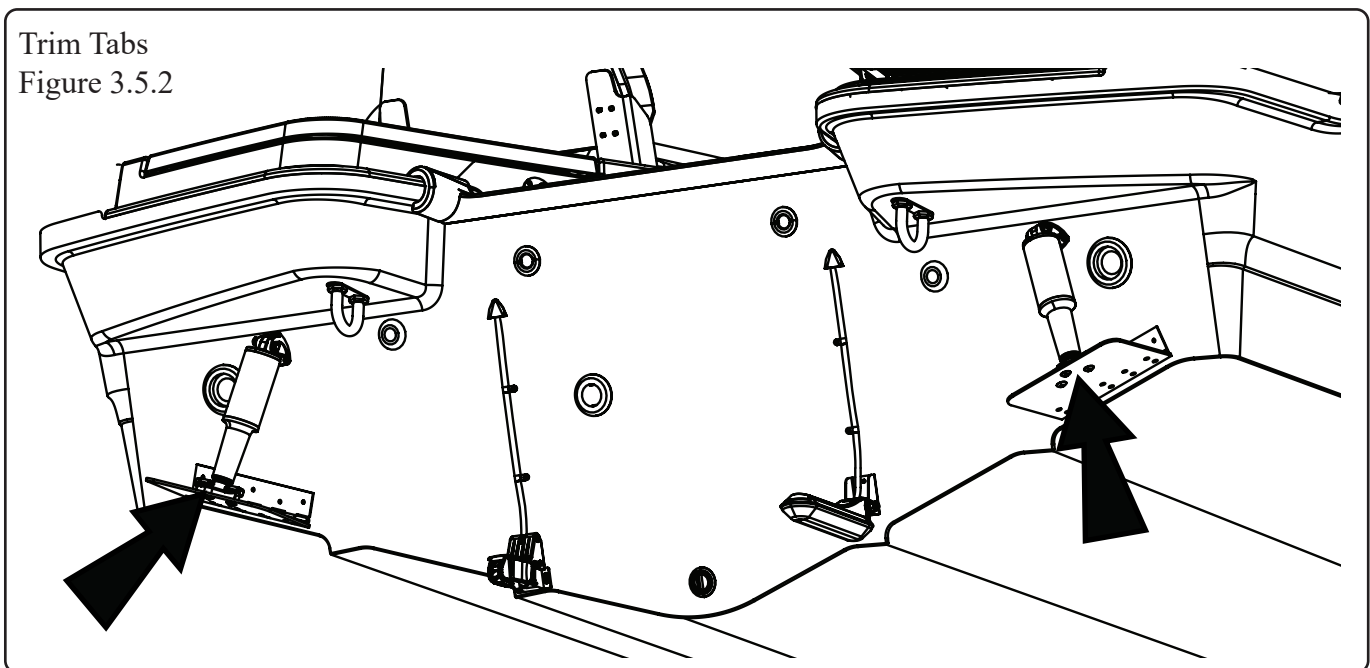

## Maintenance

The trim tabs units are sealed, waterproof and maintenance free. General cleaning is recommended, and marine growth should be removed when the boat is out of the water. Also inspect the sacrificial anodes regularly and replace as necessary, refer to chapter 5 for additional information.

REFER TO OWNER'S PACKET FOR COMPLETE INSTRUCTIONS AND WARRANTY INFORMATION.

## Bilge Pump

Located in the splashwell access hatch (see Figure 3.5.1), the pump is rated at 1100 GPH (4164 LPH) and is activated automatically by a float switch when water reaches a predetermined level.

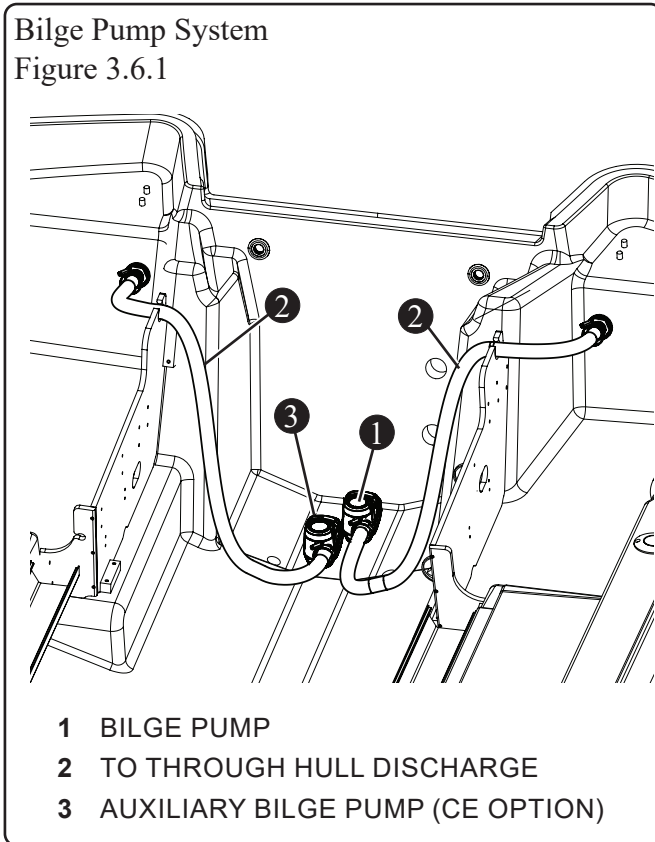

The *BILGE PUMP* switch at the helm switch panel (see Figure 3.5.2) controls pump operation. The switch should remain in the *AUTO* position when in use, unless the operator wishes to manually operate the pump by switching to the *ON* position.

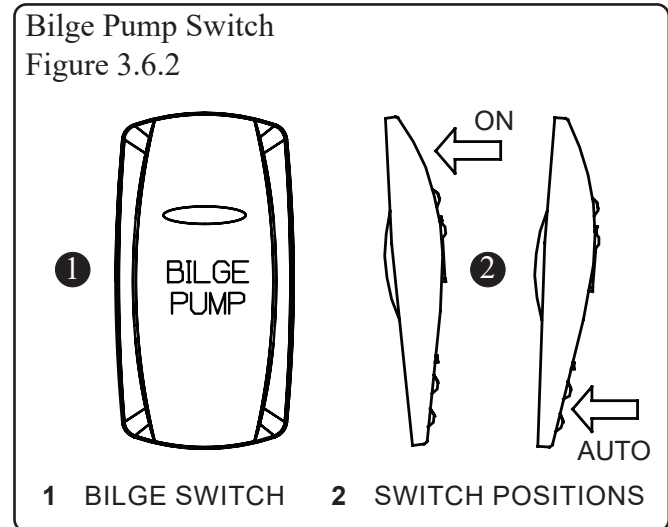

## Maintenance

Frequently inspect the area under the float switch to ensure it is free from debris and bilge oil. The float switch and pump strainer can be accessed by pressing the two locking tabs on the bilge pump (see Figure 3.5.3) and lifting off the motor cover. To clean, soak in heavy duty bilge cleaner for 10 minutes, agitating several times. Check for unrestricted operation of the float. Repeat cleaning procedure if necessary. Inspect the bilge pump water intakes and keep them free of dirt or material which may impede water flow.

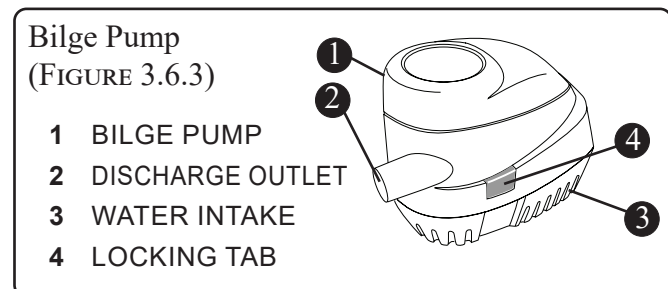

## NOTICE

**If set to the *ON* position, bilge pump operates continuously and discharges the battery. Bilge pump is wired directly to battery, so float switch must remain clear of debris to prevent continuous operation and battery discharge.**

If water does not come out of discharge:

1. Remove the motor module to see if the impeller rotates with the power on.
2. Remove any debris that may have accumulated in the nozzle section or strainer base.
3. Check hose and connection on hull side for debris and proper connections.

### Fuel and Oil Spills

Regulations prohibit discharging fuel or oily waste in navigable waters. Discharge is defined as any action which causes a film, sheen or discoloration on the water surface, or causes a sludge or emulsion beneath the water surface. A common violation is bilge discharge. Violators are subject to severe penalties and may also be responsible for the cost of cleanup which could be substantial. Use rags or sponges to soak up fuel or oily waste, then dispose of properly ashore. If a large quantity of fuel or oil is in the bilge, contact a dealer to remove it. Never pump contaminated bilge discharge overboard.

### ! CAUTION

**Oil and fuel spills can be dangerous and can subject offenders to severe penalties**

### Power Steering

The engine on this vessel incorporates power assisted steering by use of hydraulics. The reservoir is located inside the splashwell access hatch (see Figure 3.6.1). Check power steering fluid regularly and visually inspect the outside of the unit for signs of leaks or damage.

Check fluid level before each trip. If necessary add SAE 0W-30 synthetic power steering fluid only.

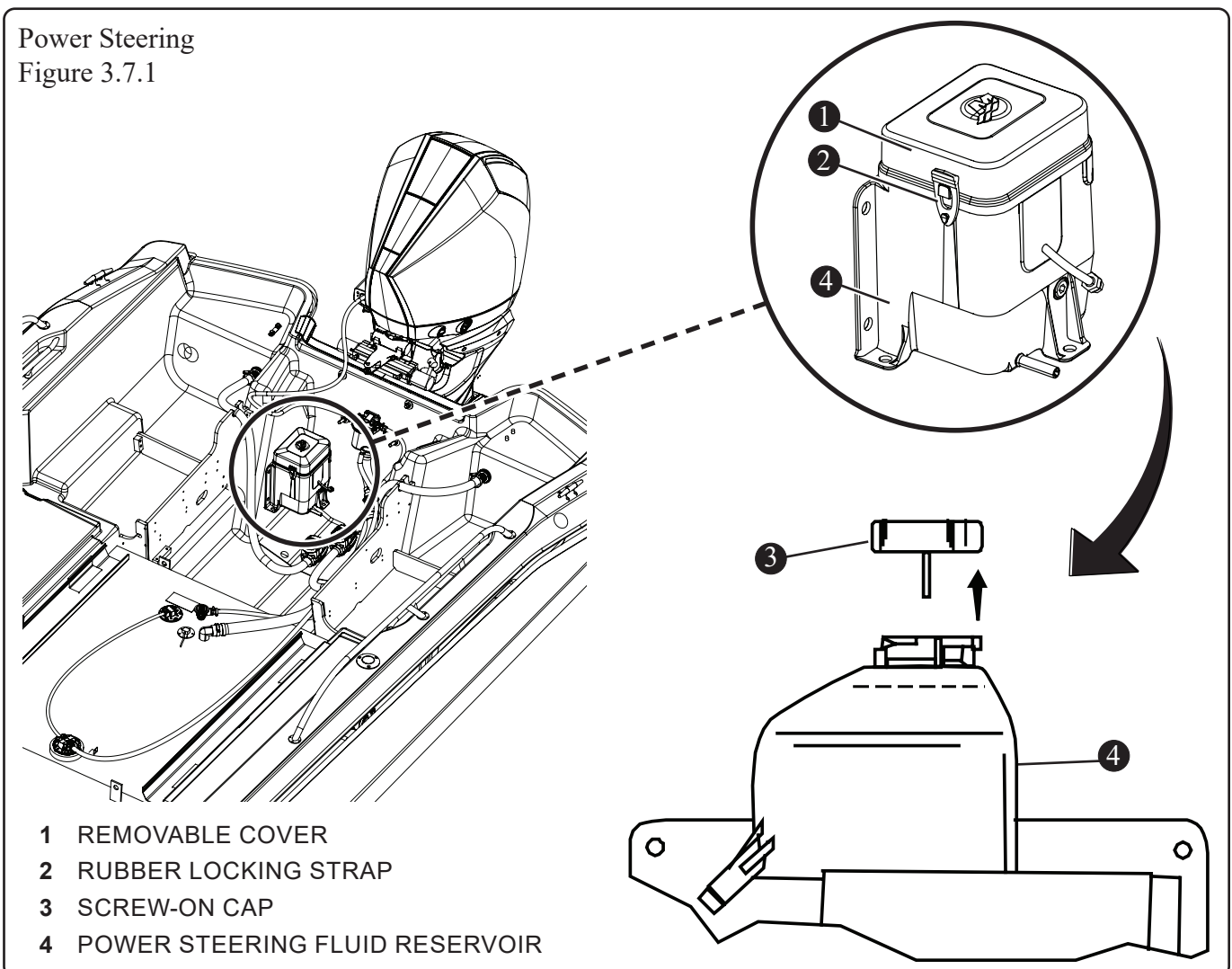

### Fuel System

#### CAUTION

- **Fuel spills can be dangerous and can subject offenders to severe penalties.**
- **Leaking fuel is a fire and explosion hazard; inspect system regularly. Examine fuel tanks and exposed lines for leaks and corrosion.**

#### CAUTION

**Use of improper fuel can seriously damage engine. Engine damage resulting from use of improper fuel is considered engine misuse and voids the warranty. Follow engine manufacturer's recommendations regarding the types of fuel and oil to use.**

#### NOTICE

**It is your responsibility to read and understand the engine manufacturer's manual in owner's packet for complete fuel and fueling information and warnings.**

The fuel system (see Figure 3.8.1) is designed to meet EPA regulations using certified components to limit fuel vapor emissions. Fuel system provides the following benefits:

- Automotive style refueling, automatic nozzle shut-off, fuel nozzle retention. This system sends a signal to the pump nozzle to shut off before there is any spit-back or well-back through the fill opening.
- Overfill protection is included with each system, reducing the possibility of accidental fuel spills.
- Reduce hydrocarbon emissions through the use of a specially designed fuel fill. This fuel fill has a permanently attached cap with a positive closure mechanism that features an audible click, to inform when it is sealed.

### Fuel Tank

The low-permeation aluminum fuel tank (see Figure 3.8.1) has a usable fuel capacity of 95 gallons (359.6 liters). Review and understand all

fuel related information and warnings in the owner's packet and the included safety inserts. When the fuel tank is less than one-quarter full, this can cause engine stalling due to fuel starvation or by allowing sediment to enter the fuel line. Keep tank full and monitor fuel level often.

### Fuel Vent

The fuel tank vent is integrated into the fuel fill deck fitting. The VaporTec fuel pressure management system (fuel fill deck fitting, integrated check valve, fill limit vent valve, and grade valve) ensures that the fuel system maintains proper vapor pressure, which, if unchecked, can seriously damage a boat or engine. The vent serves as an over pressure/vacuum release with anti-surge and flame/spark arresting protection. Grade valves have been added to the tank to allow proper ventilation when the boat is stored, or trailered, on a moderate incline, without fuel seepage.

### Fuel Distribution System

Fuel is delivered to the engine through the fuel valve, anti-siphon valve (ASV) and the fuel line. The fuel valve prevents built up tank pressure from being transferred to the engine while still allowing fuel to flow. The anti-siphon valve is a safety feature designed to prevent fuel from siphoning out of the tank if the fuel line were to be cut or broken below the level of the fuel in the tank.

### Filling the Tank

#### WARNING

**Fuel system on this vessel complies with all applicable ABYC standards. Fueling station pump flow rates exceeding 18 gallons (68 liters) per minute may damage system components and cause fuel leakage into the vessel.**

The fuel system is designed to automatically shut off the fuel nozzle when the tank is full, similar to an automotive fuel system. The tank is filled when the fuel fill nozzle has shut itself off the second time. The SecureStop automatic fuel shut off system (fuel fill deck fitting, integrated check valve, fill limit vent valve), ensures a clean a trouble-free fill-up. Attempting to fill the tank past this point may cause some components to malfunction.

## Fuel System

Fuel System  
Figure 3.9.1

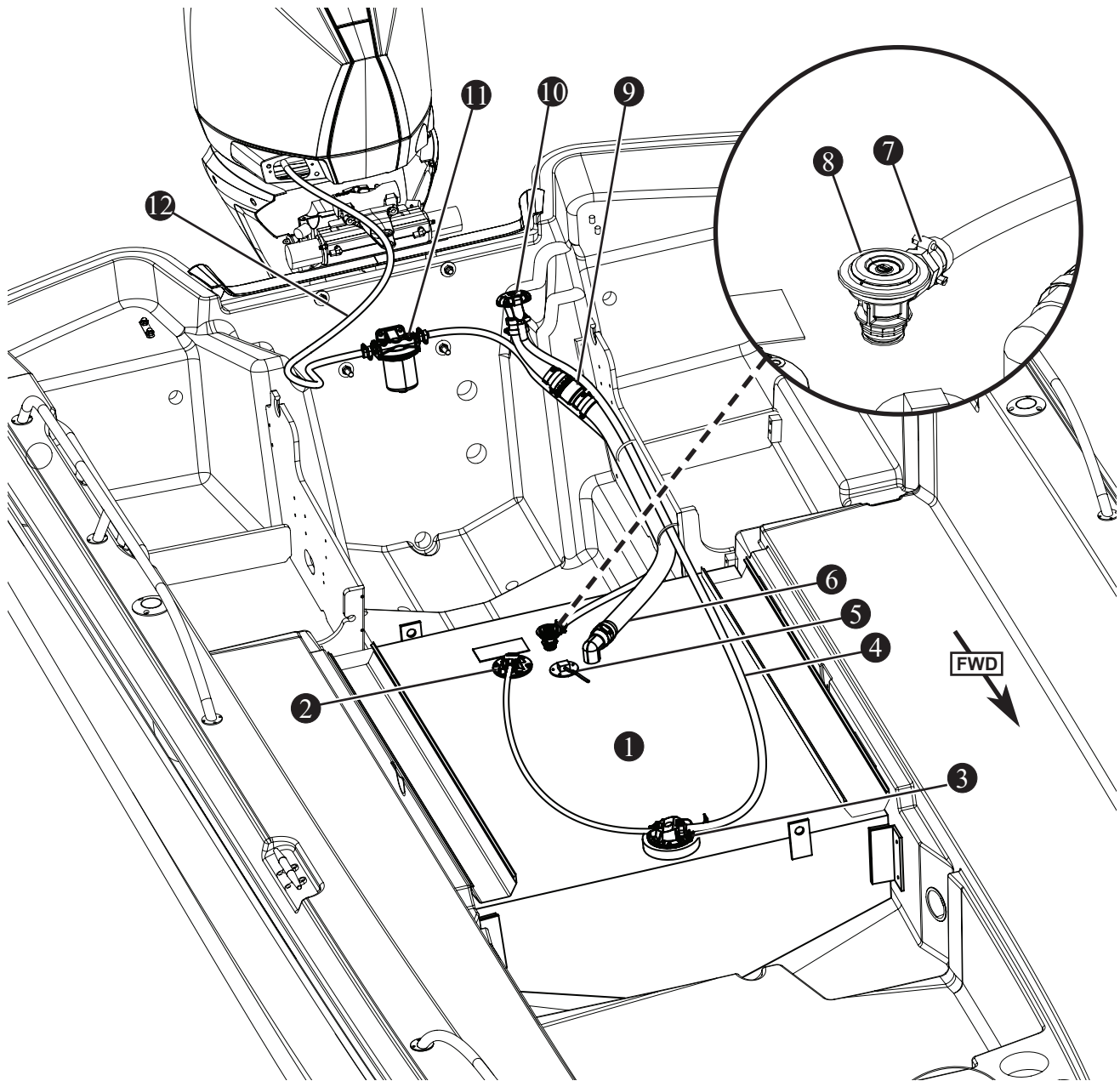

- |                         |                       |
|-------------------------|-----------------------|
| 1 FUEL TANK             | 7 ANTI-SIPHON VALVE   |
| 2 GRADE VALVE           | 8 FUEL DEMAND VALVE   |
| 3 FILL LEVEL VENT VALVE | 9 INLET CONTROL VALVE |
| 4 FUEL VENT HOSE        | 10 FUEL FILL          |
| 5 FUEL TANK SENSOR      | 11 FUEL FILTER        |
| 6 FUEL FILL HOSE        | 12 ENGINE FUEL FEED   |



### **WARNING**

**Use of a portable fuel container to fill fuel tank can result in overfilling and circumvent the safety features designed into fuel tank.**

### **WARNING**

**Modification of any fuel system components or replacement of these components with unauthorized parts may result in over-pressurization of fuel system and circumvent safety features designed into tank.**

### **NOTICE**

**Record this vessel's fuel capacity and consumption. Drastic changes in consumption and mileage may indicate a problem.**

### **DANGER**

- **Static electricity can ignite gasoline vapors causing serious injury, death and/or destruction of property.**
- **Check for leaks in tubing, connections and hoses. Avoid all forms of ignition when the fuel fumes are noticed.**
- **Correct the cause of leaks and ventilate the area to insure that no fumes remain prior to energizing any electrical equipment, smoking and/or starting the engine.**

### **NOTICE**

**Fuel gauge reads accurately only when boat is level (not underway).**

#### **Static Electricity**

Static electricity can ignite gasoline vapors. Use extreme caution when fueling from a source other than marinas and gas stations. This vessel's bonding system protects it from creating and discharging static electricity. Keep vessel in contact with the water or a land-based grounding system. To reduce static electricity while refueling:

- Never fuel boat in unsafe conditions such as suspended on a sling or in a situation that increases the likelihood of static discharge.

- Never use homemade containers to fill tanks.
- Fuel carried on-board outside of a fixed fuel system should be stored in an approved container or in a portable tank such as provided for outboard engines and be stowed safely outside of the engine or living compartment(s).
- Shut down the engine, motors and fans prior to taking on fuel. Any ignition sources should be extinguished before filling the fuel tank.
- Close all ports, windows, doors and hatches.
- Fueling should never be done at night except in well lit areas.
- Always keep fuel nozzle in contact with edge of the fuel tank opening when filling.
- Ventilate areas where gasoline vapors could collect before starting the engine.
- Wipe up any spillage completely and dispose of rags or waste on shore.
- Secure the fill cap tightly.
- Portable tanks should only be filled while on shore, never on board the boat.

REFER TO THE SAFETY INSERTS IN THE OWNER'S PACKET FOR MORE INFORMATION.

#### **Ethanol Blended Fuels**

### **NOTICE**

**The use of improper gasoline or additives can damage the fuel system and is considered misuse of the system. Damaged caused by improper gasoline or additives is not covered under warranty.**

### **CAUTION**

**The use of fuels containing ethanol higher than 10 percent (E-10) can damage engine and/or fuel system and will void the warranty.**

Ethanol's high-octane rating may be useful in increasing the octane level of unleaded gasoline. The fuel system components of Mercury engines have been tested to perform with a 10 percent maximum level of ethanol-blended gasoline. Special

precautions should be considered with the use of fuel containing ethanol in the fuel system. Fuels with ethanol can attack some fuel system components, such as tanks and lines, if they are not constructed from ethanol compatible materials. This can lead to operational problems or safety issues such as clogged filters, leaks or engine damage.

This vessel was manufactured and shipped from the factory with ethanol compatible materials. Before introducing gasoline with ethanol into the fuel tank, ask the dealer if any components have been added or replaced that are not recommended by Boston Whaler, Mercury, or may not be ethanol compatible. It is best to maintain a full tank of fuel when the vessel is not in use. This will reduce air flow in and out of the tank due to changes in temperature as well as limiting ethanol exposure to humidity and condensation in the tank.

### Phase Separation

Humidity and condensation create water in the fuel tank which can adversely effect the ethanol blended fuel. A condition called phase separation can occur if water is drawn into the fuel beyond the saturation point. The presence of water in the fuel beyond the saturation level will cause most of the ethanol in the fuel to separate from the bulk fuel and drop to the bottom of the tank, significantly reducing the level of ethanol in the fuel mixture in the upper level (phase). If the lower level (phase), consisting of water and ethanol, is deep enough to reach the fuel inlet, it could be pumped directly to the engine(s) and cause significant problems. Engine problems can also result from the reduced ethanol/fuel mixture left in the upper phase of the tank. There is no practical additive known that can prevent or correct phase separation. The only solution is to keep water from accumulating in the tank. If phase separation does occur, the only remedy is to drain the fuel, clean and dry the tank completely and refill with fresh fuel.

### Fuel/Water Separators

A fuel water separator (filter) is provided for the engine. The addition of another in-line filter to the system may create a possible flow restriction that can starve the engine of fuel. It is advisable to carry extra on-engine filters in case filter plugging from debris

in the fuel tank becomes a problem during boating. Consult a Boston Whaler dealer for recommendations regarding filters that meet Mercury's specifications.

### Maintenance

Periodically inspect for the presence of water in the fuel tank. If any is found, all water must be removed and the tank completely dried before refilling the tank with any fuel containing ethanol.

### Fuel and Boat Storage

Long periods of storage and/or non-use, common to boats, create unique problems. When preparing to store a boat for a period of two months or more, it is best to completely remove all fuel from the tank. If not possible, fill tank and add fuel stabilizer per manufacturer's instructions. Maintaining a partially full tank during storage is not recommended because the void above the fuel allows air movement that can introduce water through condensation.

## NOTICE

**Carry spare filters onboard as contaminated fuel can easily clog a filter.**

### Navigation Lighting

This vessel comes equipped with navigation lighting for safety (for location information refer to chapter 2, *General Information*). Regulations state that all boats must display navigation lights between sunset and sunrise and during periods of restricted visibility, such as rain, fog, haze, etc. If operating in reduced visibility or between sunset and sunrise it is necessary to maintain a safe speed and post a lookout.

It is the operator's responsibility to ensure that the navigation lights are in good working order and that the proper lighting is shown and not obstructed in its intended arc of visibility. This vessel's navigation lights may include an expiration date on the housing. If one is located, replace light before expiration date, even if light is functional, as lighting quality may be compromised.

Do not add lights that interfere with required navigation lights. Some lights, such as blue colored

lights, may be illegal to display on a boat. It is the owner's responsibility to ensure that displayed lights are also compliant with local regulations.

### NOTICE

**The improper sequence of navigation lighting may be as dangerous as no lighting at all.**

NAV/ANC Switch

Figure 3.12.1

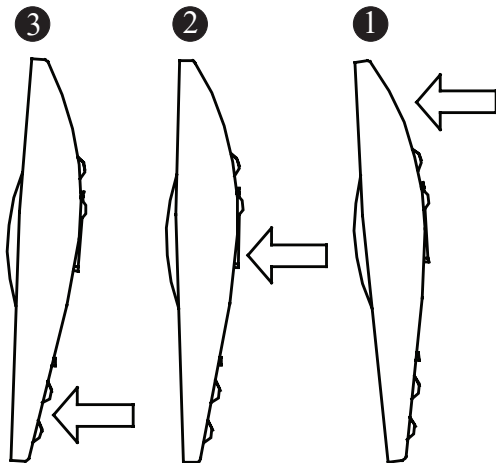

- 1 ALL NAVIGATIONAL LIGHTS "ON"
- 2 ANCHOR LIGHT ONLY "ON"
- 3 "OFF"

### Freshwater System (Option)

### NOTICE

- **Be sure to fill water tank from a source known to provide safe, pure drinking water.**
- **If do not use the freshwater system for long periods of time or only use it seasonally it is recommended that disinfect the system before using it.**

The freshwater system includes: pump, plumbing, holding tank and connections for water service. The 12 gallon (45 liter) freshwater tank's fill cap is located on the port side of the console lounge seat (see Figure 3.12.1) The freshwater shower is located in the starboard side of the stern deck. Fill the tank only from a source known to provide safe, pure drinking water. Use only a plastic hose to fill the water tank. Using a rubber hose can give the water a disagreeable

taste. Before fill the freshwater system it is vital that it be properly disinfected. Ask your dealer if this has been done. The following procedure is recommended to disinfect the freshwater system:

1. Flush the entire system thoroughly by allowing potable water to flow through it.
2. Drain the system completely.
3. Fill the entire system with an approved disinfecting solution (check with your dealer for recommendations) and follow the method prescribed by the manufacturer.
4. After disinfecting, drain the entire system.
5. Flush the entire system thoroughly several more times with potable water.
6. Now the system is ready for use, fill with potable water.

This should be done annually or before first use after being stored for an extended period of time.

### Raw Water Washdown (Option)

The raw water deck fitting is located on the port side of splashwell (see Figure 3.14.1). The fitting allows for connection of a common garden hose. The cap is tethered to the fitting and on the connection when not in use.

### Operation

The raw water washdown pump is activated by the *WASHDOWN* switch on the helm switch panel.

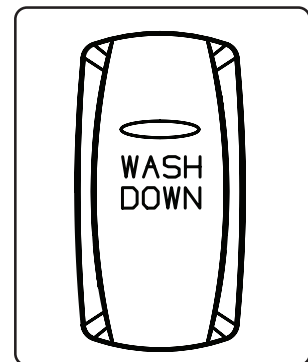

## Freshwater System (Option)

Freshwater System (Option)  
Figure 3.13.1

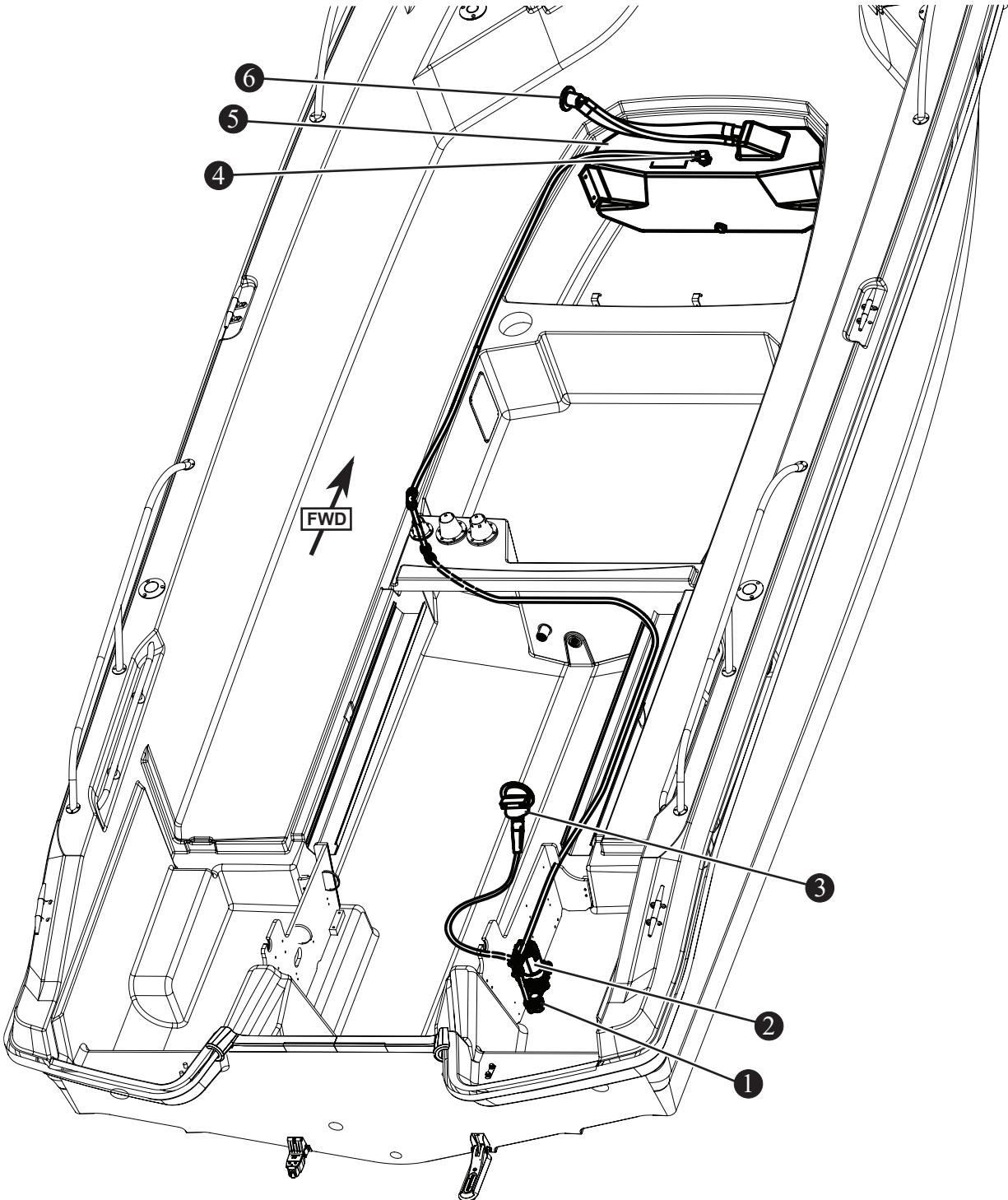

- 1 WATER FILTER
- 2 WATER PUMP
- 3 SHOWER

- 4 WATER TANK PICKUP
- 5 12 GAL (45 L) WATER TANK
- 6 VENTED WATER FILL

### Raw Water System Maintenance

Check fittings and hoses for system integrity to prevent leaks. The system should be run at least every other month to keep the pumps' impellers in good condition. When the boat is out of the water, clean the seacock intake(s) on the bottom aft of the hull to keep free of any debris or build-up.

### Livewell

The livewell located in the center of the stern deck keeps baitfish alive by circulating fresh seawater through the tank (see Figure 3.13.1 and Figure 3.14.1). Before operating the system, ensure the intake seacock and flow control valve are in the open position. The seacock (see Figure 3.14.1) can be accessed through the splashwell access hatch. The flow control valve allows water flow adjustment into the livewell tank. Turn the handle clockwise to stop the flow of water. Fill the livewell by pressing the switch marked *LIVEWELL* on the helm switch panel. A drain tube connects to the livewell overflow drains and directs overflow water to a transom thru-hull drain. Regulate the amount of water in the livewell by inserting the drain plug into the lower drain thus raising the level of water to the overflow drain.

### Maintenance

Maintenance of the livewell system requires periodic inspection of the raw water intake strainer and all hose connections. Clean away debris and/or tighten hose connections as required.

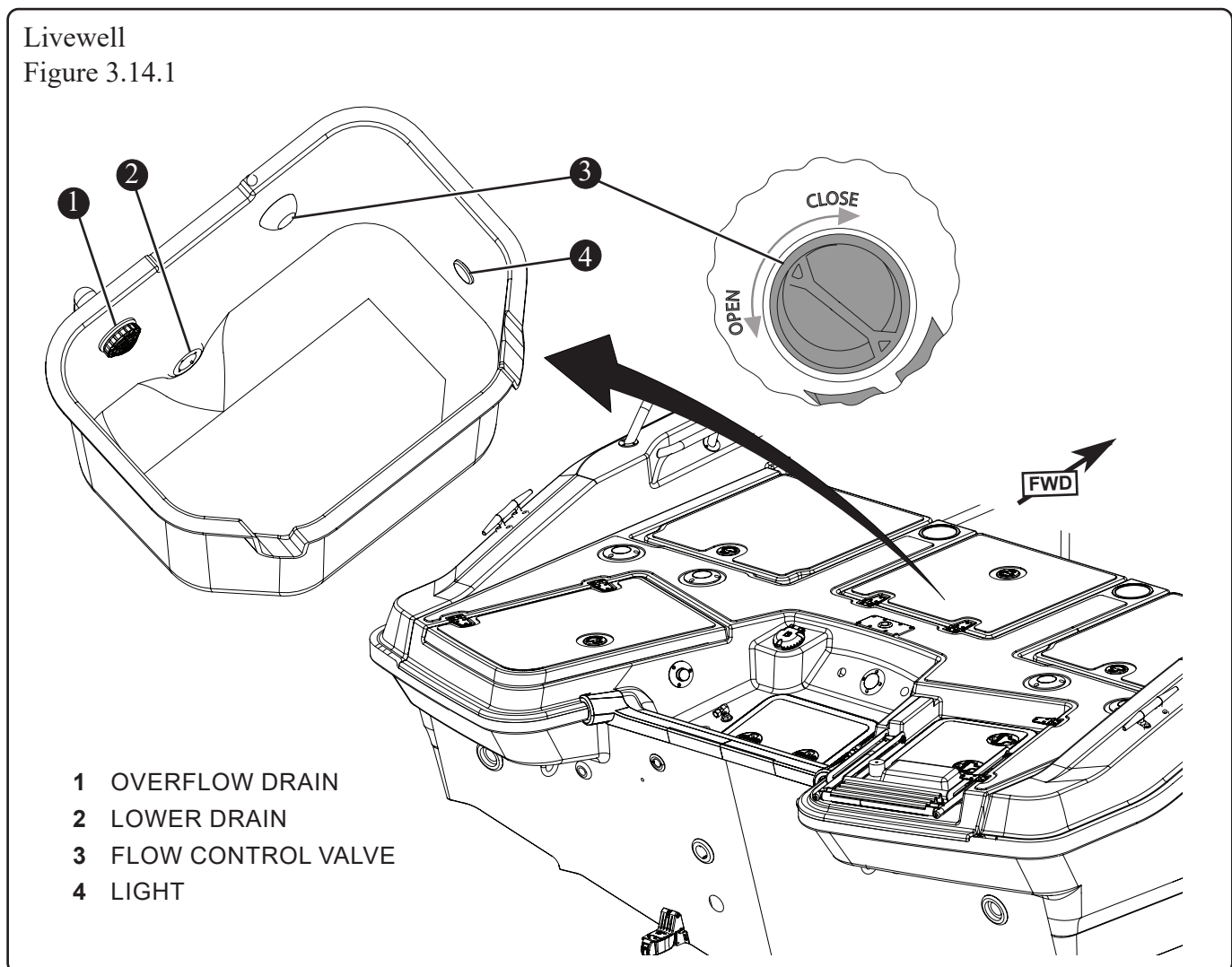

Livewell and Raw Water  
Figure 3.15.1

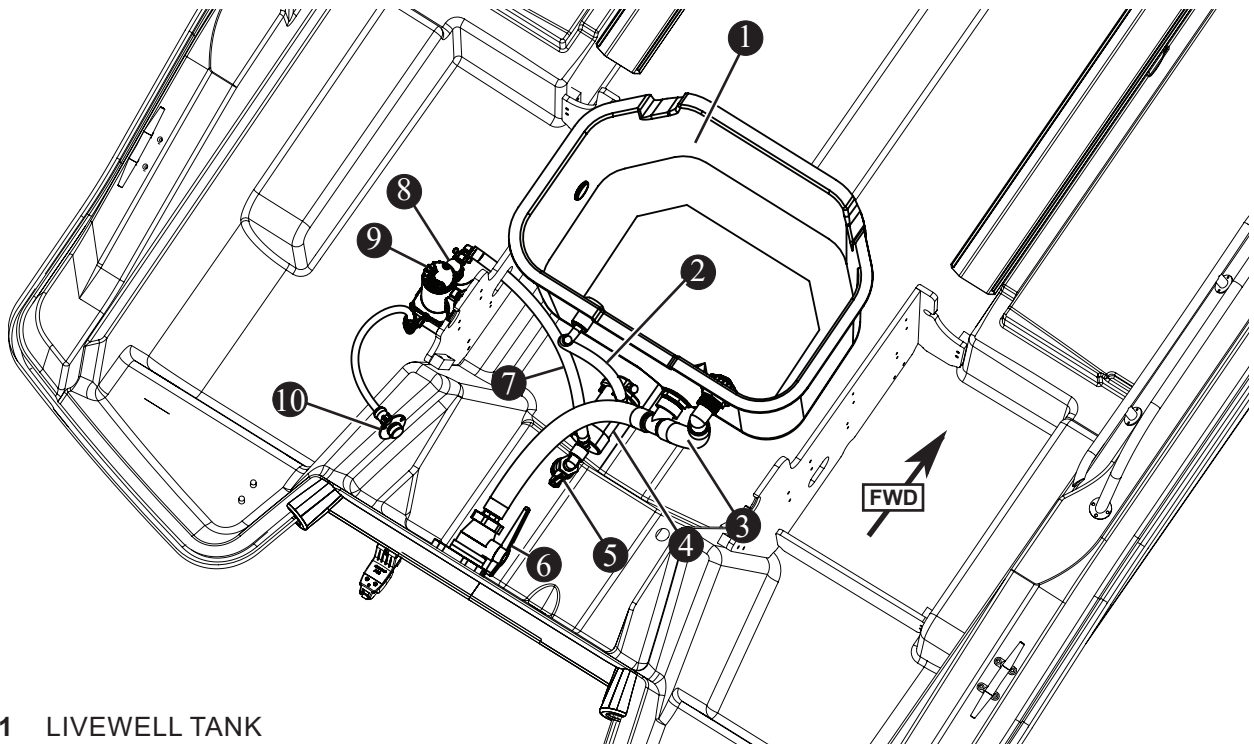

- 1 LIVEWELL TANK
- 2 LIVEWELL FILL HOSE
- 3 OVERFLOW AND DRAIN HOSE
- 4 LIVEWELL PUMP
- 5 LIVEWELL & RAW WATER PICKUP SEACOCK
- 6 DRAIN SEACOCK
- 7 RAW WATER PICKUP HOSE (OPTION)
- 8 RAW WATER FILTER (OPTION)
- 9 RAW WATER PUMP (OPTION)
- 10 RAW WATER WASHDOWN DECK CONNECTION (OPTION)

## NOTICE

If seacock and flow control valve are left open while vessel is underway, water may enter livewell.

## ATTENTION

The seacock must be in the open position when livewell and washdown are in use. Running the pump dry may damage the unit.

### Environmental Considerations

The Environmental Protection Agency (EPA) standards state that in freshwater lakes, reservoirs, impoundments whose inlets or outlets are such as to prevent the ingress or egress by vessel traffic subject to this regulation, or in rivers not capable of navigation by interstate traffic subject to this regulation, marine sanitation certified by the United States Coast Guard (U.S.C.G.) installed on vessels shall be designed and operated to prevent the overboard discharge of sewage, treated or untreated or any other waste derived from sewage. The EPA standards further state that this shall not be construed to prohibit the carriage of Coast Guard certified flow through treatment devices which have been secured so as to prevent such discharges. They also state that the waters where a Coast Guard certified marine sanitation device permitting discharge is allowed include: Coastal waters, Estuaries, The Great Lakes and Intercoastal waterways, Freshwater lakes and Impoundments accessible through locks and other flowing waters that are navigable interstate by vessels subject to this regulation (40 CFR, 140.3).

## Head with Optional Waste Pumpout

This vessel is fitted with a portable head (see Figure 3.15.1). The system is located inside the console. It has an upper unit that holds freshwater for flushing and a lower unit for waste containment. Waste is directed to the waste containment unit which holds 2.8 gallons (10.6 liters).

### Dockside Waste Pumpout (Option)

If equipped, the waste pumpout is located on the port console exterior below the windshield and is marked *WASTE* (see Figure 3.15.1). Open the cover with a multi-pin key included in the owner's packet. Most dockside facilities have a connection to fit this boat. Dockside discharge is always the preferred method of waste disposal.

## NOTICE

**Severe state and federal penalties are levied for discharging raw sewage and/or solid waste in waters where it is not permitted.**

Head (Standard)  
Waste Pumpout (Option)  
Figure 3.16.1

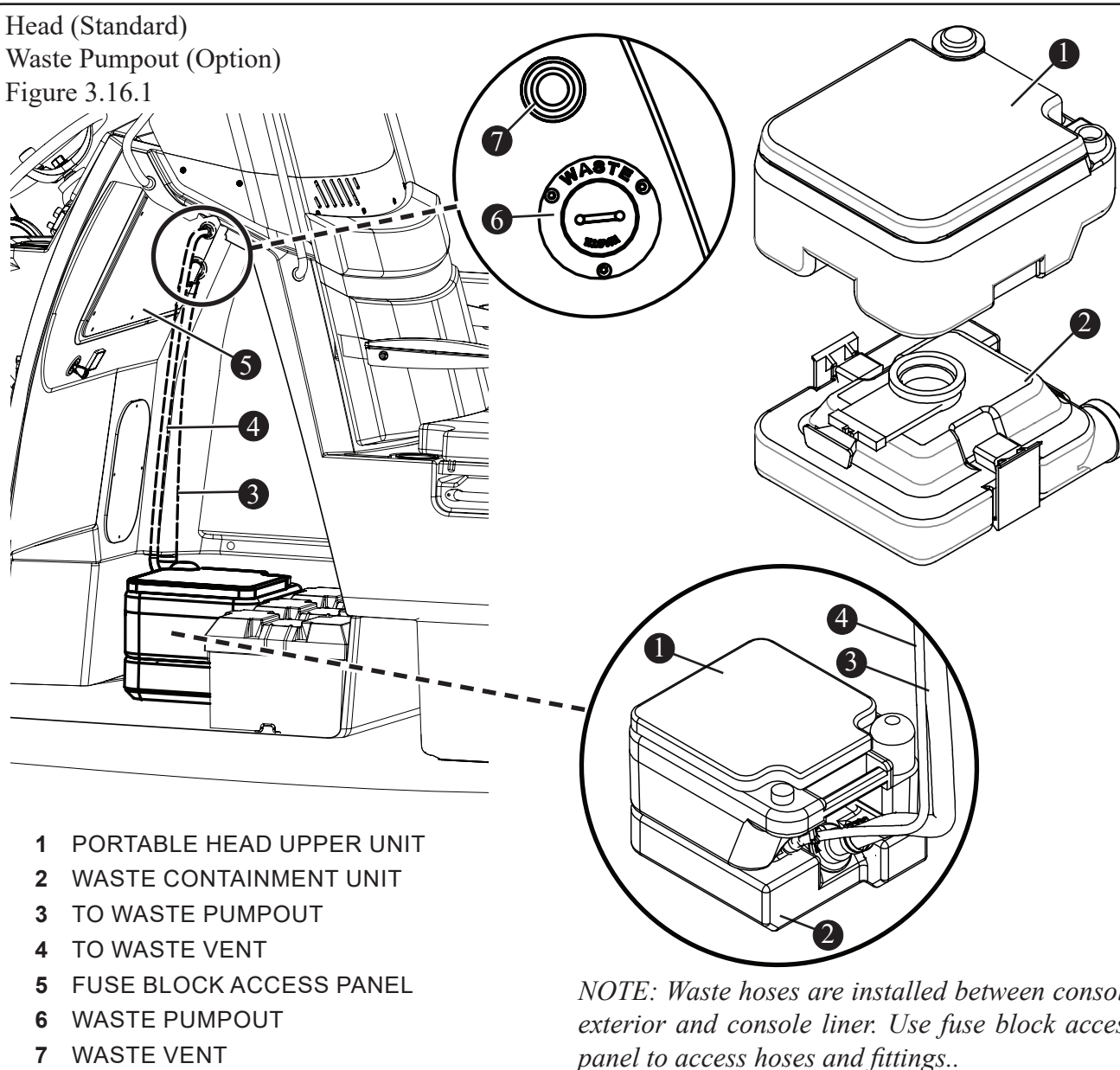

*NOTE: Waste hoses are installed between console exterior and console liner. Use fuse block access panel to access hoses and fittings..*

## Helm Seat with Livewell (Option)

If equipped, the additional 25 Gallon (94,6 L) livewell is located in the helm seat under the seat cushion (See Figure 3.16.1). This livewell can be filled by pressing the switch marked *L/P LIVEWELL* on the helm switch panel. The livewell bucket has an overflow fitting attached to the drain.

Be sure the hull seacock and the overflow drain seacock are in the open position. Both seacocks can be reached by removing the motorwell hatch. Turn the seacocks counterclockwise to open.

### Maintenance

Maintenance of the livewell system will require to check the seacock intake strainer for debris and impediments, this can be done visually on dry land. The intake strainer is located on the bottom aft of the hull on the starboard side.

Helm Seat with Livewell (Option)  
Figure 3.17.1

NOTICE

If seacock and flow control valve are left open while vessel is underway, water may enter livewell.

---

ATTENTION

The seacock must be in the open position when livewell and washdown are in use. Running the pump dry may damage the unit.

1 ROD HOLDER	7 LOWER DRAIN PLUG	13 RAW WATER SEACOCK
2 LIVEWELL LID	8 LIGHT	14 LIVEWELL PUMP
3 REMOVABLE SEAT CUSHION	9 OVERFLOW DRAIN	15 LIVEWELL FILL HOSE
4 LIVEWELL PLUMBING ACCESS	10 FLOW CONTROL VALVE	16 LIVEWELL TANK
5 HELM SEAT	11 DRAIN SEACOCK	
6 LOWER DRAIN	12 DRAIN HOSE	



## Bow Table (Option)

If equipped, the bow table is assembled on the aft wall of the bow lounge. The table components are located behind the helm in the console storage. To install (see Figure 3.17.1):

### Bow Table (Option)

Figure 3.18.1

1. Retract the mounting bracket locking pin and insert the support post into the bracket; release locking pin.

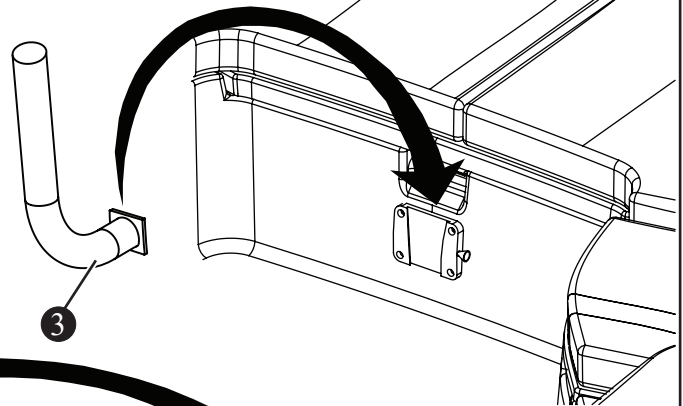
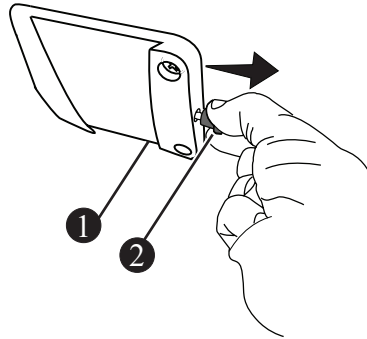

2. Place the bow table onto the support post.

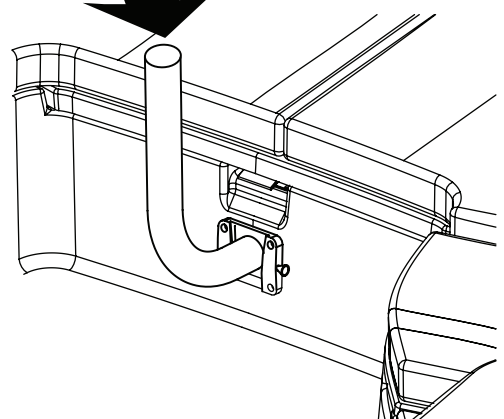
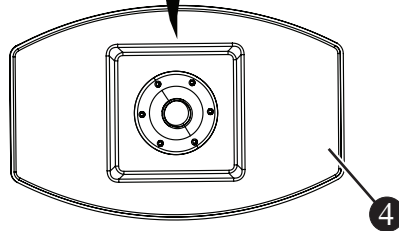

- 1 MOUNTING BRACKET
- 2 BRACKET LOCKING PIN
- 3 SUPPORT POST
- 4 BOW TABLE

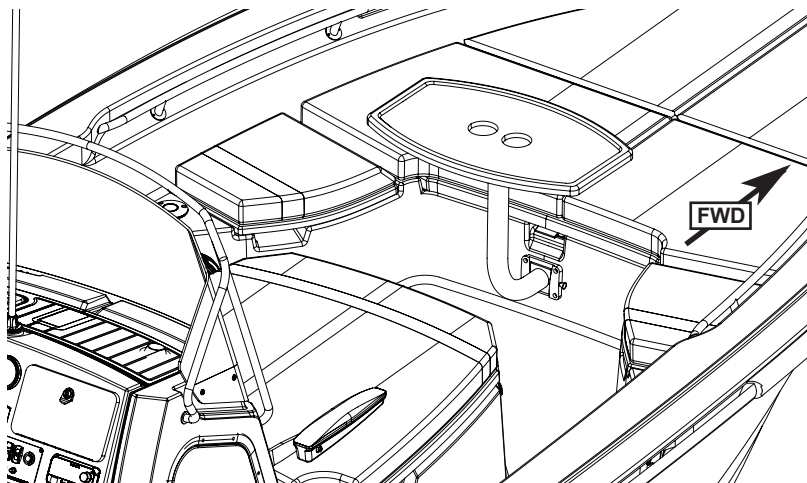

### 36V Trolling Motor Panel with 12V Outlet (Option)

The 250 Dauntless can be equipped with an optional trolling motor panel located above the anchor locker interior facing aft Figure 3.18.1. This option consists of:

- Trolling motor panel
- Three battery boxes, (in the console).
- One 70 amp circuit breaker (in the console).
- Reinforced deck, (port side of the bow).

There are a variety of trolling motors and mounts that can be fitted to this boat. See a Boston Whaler dealer for the right type and size of trolling motor and battery that will work best with this boat. There is a section of the port bow that has been reinforced with phenolic to allow for securing the trolling motor base. The phenolic material can be drilled and tapped to hold machine screws. When looking for a trolling motor will need to know the distance from the top of the deck to the waterline, (Figure 3.18.2).

There are three battery boxes that have been secured in the console interior and can be accessed through the door on the starboard side. The wiring from the panel to the battery has been installed. Contact a Boston Whaler dealer or a qualified marine electrician to make final connections to the trolling motor panel.

#### WARNING

**There is a risk of electrical shock. Always have a qualified marine electrician install any system upgrades that are not already installed on the boat. There are a variety of wiring configurations up to 36 Volts. Incorrect wiring will adversely affect the trolling motors performance. Always use the correct circuit protection and wire gauge when installing an upgraded trolling motor wiring system.**

Trolling Motor Panel (Option)

Figure 3.19.1

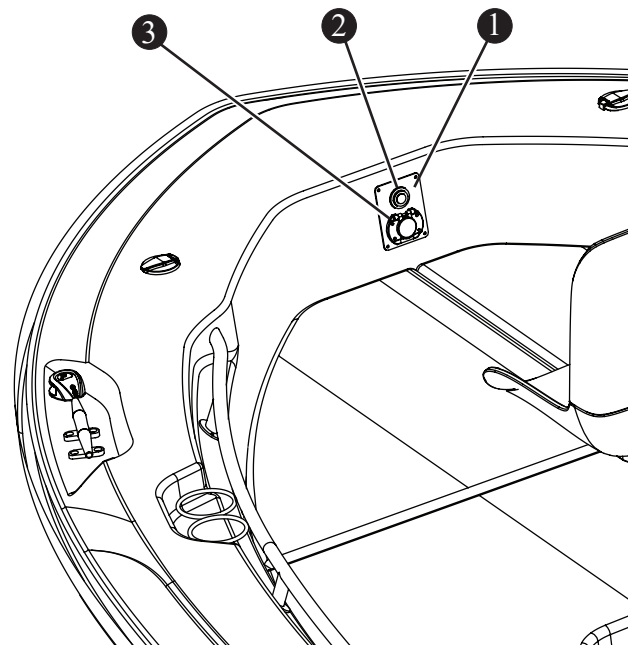

- 1 TROLLING MOTOR PANEL
- 2 12V OUTLET
- 3 TROLLING MOTOR RECEPTACLE

See chapter 4, *Electrical*, for wiring setup for 36V trolling motor electrical power.

Deck to Waterline Reference

Figure 3.19.2

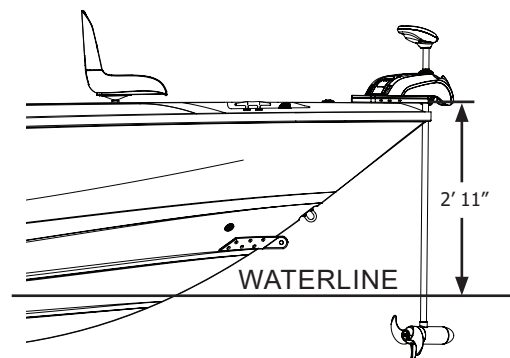

REFER TO THE MANUFACTURER'S MANUAL IN THE OWNER'S PACKET FOR COMPLETE INSTRUCTIONS AND WARRANTY INFORMATION.

Trolling Motor 36V with Charger (Option)  
Figure 3.20.1

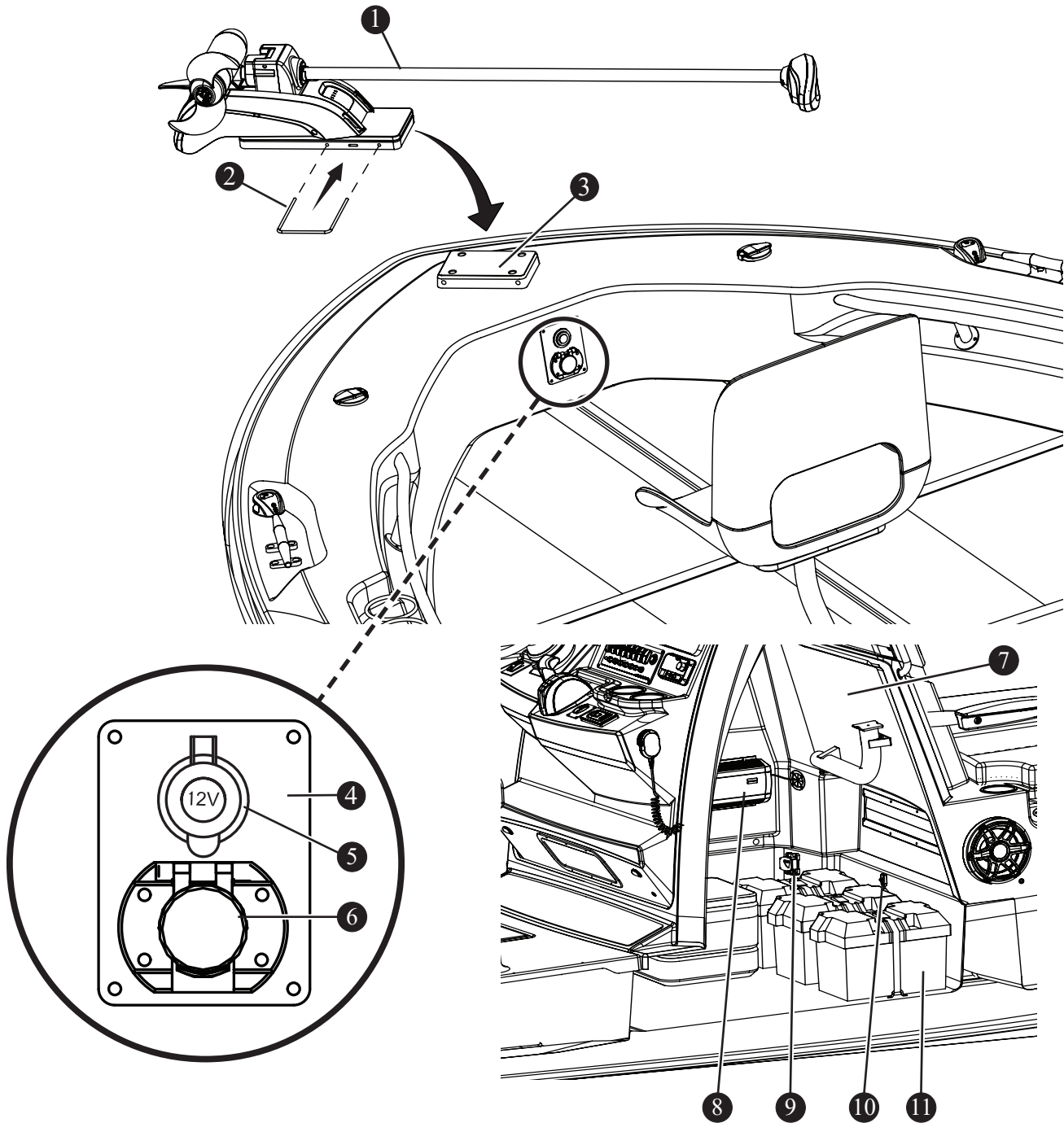

- 1 TROLLING MOTOR
- 2 QUICK RELEASE HANDLE
- 3 TROLLING MOTOR MOUNT
- 4 TROLLING MOTOR PANEL
- 5 12 VOLT OUTLET
- 6 TROLLING MOTOR RECEPTACLE

- 7 CONSOLE STORAGE (DOOR NOT SHOWN)
- 8 BATTERY CHARGER
- 9 CIRCUIT BREAKER (70 AMP)
- 10 12 VOLT OUTLET FUSE (15 AMP)
- 11 BATTERY BOXES (3)

### Shallow Water Anchor (Option)

If equipped, the optional shallow water anchor allows to remain in position in waters up to 10' deep. The shallow water anchor is activated by use of a wireless dash mounted switch on the console which deploys and retracts the unit quickly and quietly.

REFER TO THE MANUFACTURER'S MANUAL IN OWNER'S MANUAL PACKET FOR COMPLETE INSTRUCTIONS AND WARRANTY.

Shallow Water Anchor (Option)

Figure 3.21.1

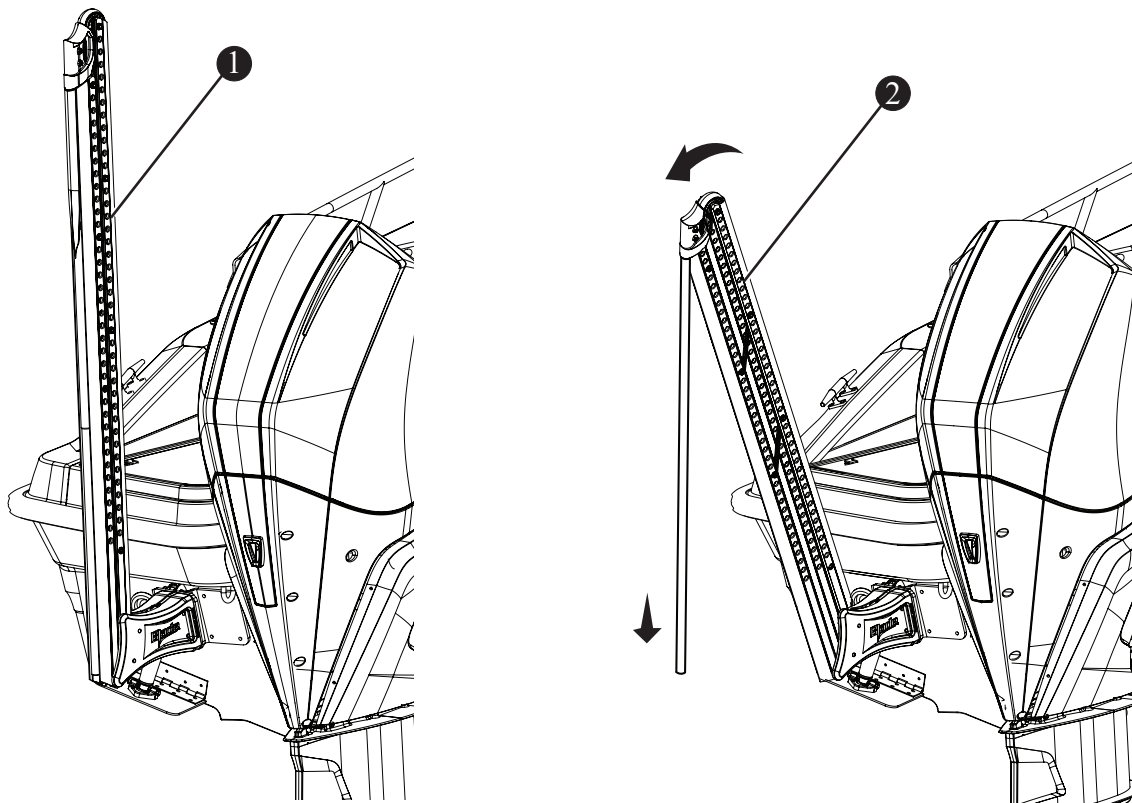

- 1 SHALLOW WATER ANCHOR (RETRACTED)
- 2 POWER POLE (DEPLOYING)
- 3 HYDRAULIC PUMP

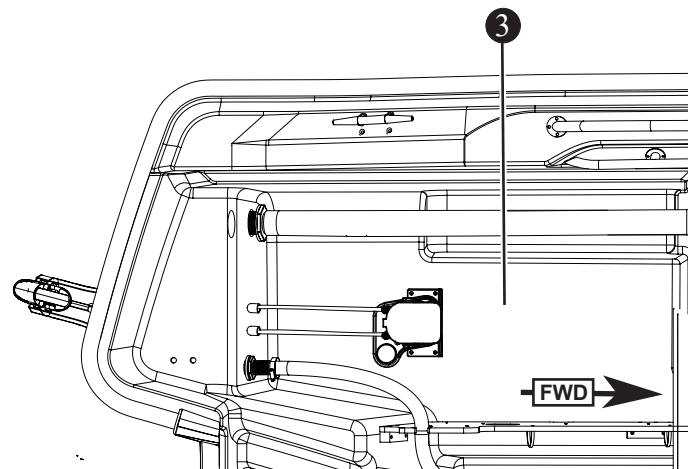

### Jack Plate (Option)

If equipped, the optional jack plate allows to raise or lower the engine vertically. In addition to allowing access to shallow waters the jack plate when raised, positions the propeller closer to the water line, reducing drag of the lower unit and increasing speed.

REFER TO THE MANUFACTURER'S MANUAL IN OWNER'S MANUAL PACKET FOR COMPLETE INSTRUCTIONS AND WARRANTY.

Jack Plate (Option)

Figure 3.22.1

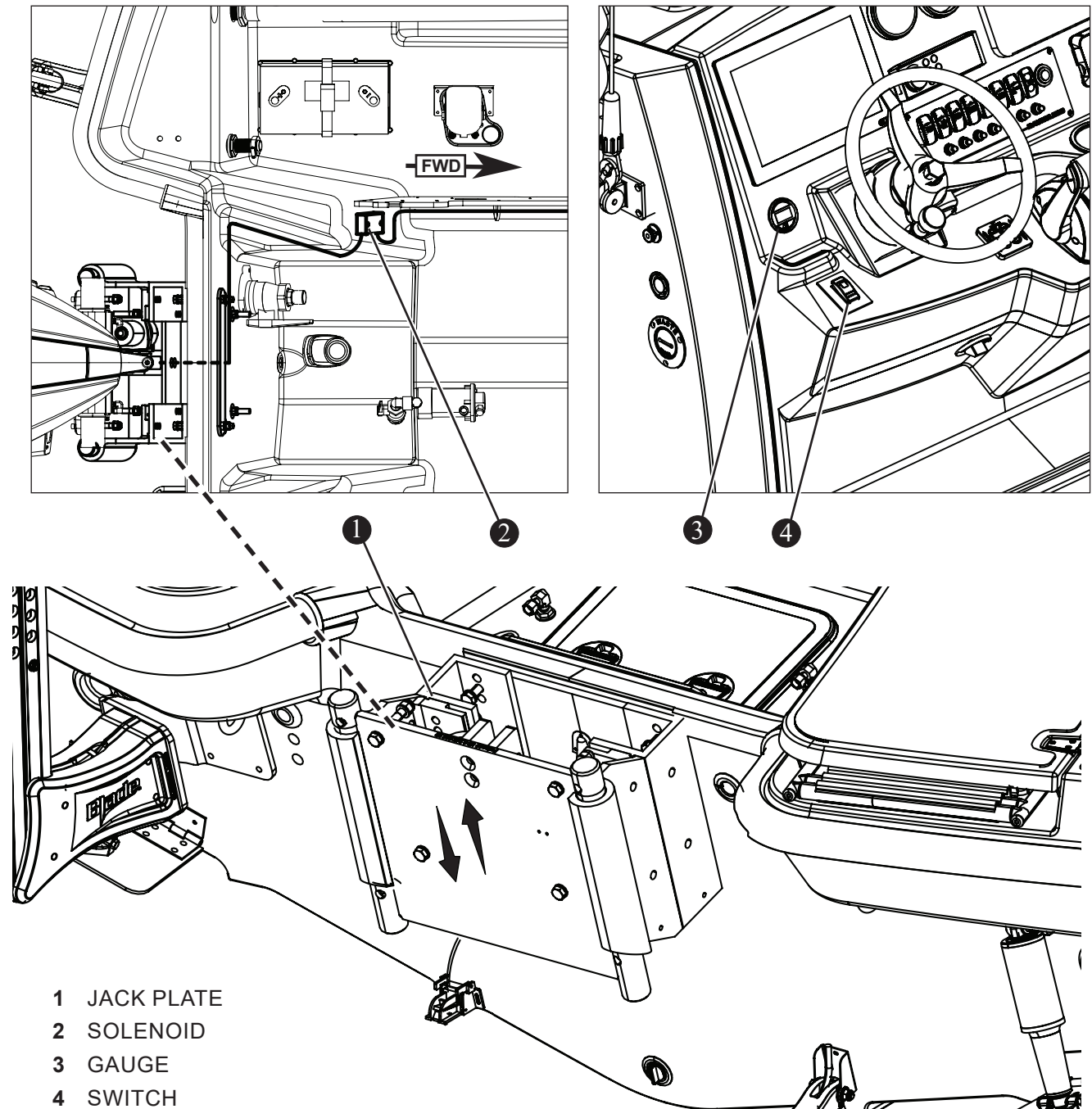

## Reboarding Ladder

The reboarding ladder is located under the ladder cover on the aft starboard deck of the boat (see Figure 3.22.1). The ladder can be accessed without the cover raised. To deploy the reboarding ladder:

1. Release ladder's locking strap.
2. Pull ladder out and extend down.
3. Extend ladder rungs.

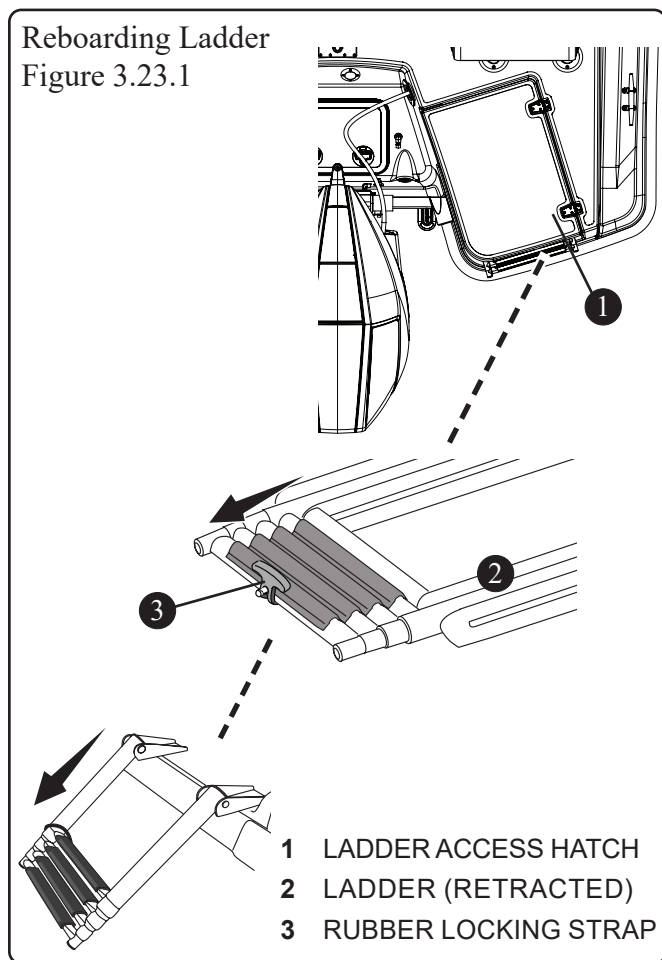

## Watersports Tow Point (Option)



**Do not use watersports tow point with any equipment tied to the tow rope.**

The watersports tow point is used for skiing or wakeboarding only (see Figure 3.22.2). If engaged in tubing or such other activities requiring the watersports equipment to be tied to the boat, attach the tow rope to the stern eyes at the transom (see Figure 3.23.2). Read and understand the safety rules for recreational activities in Chapter 1, *Safety*.

Figure 3.23.2

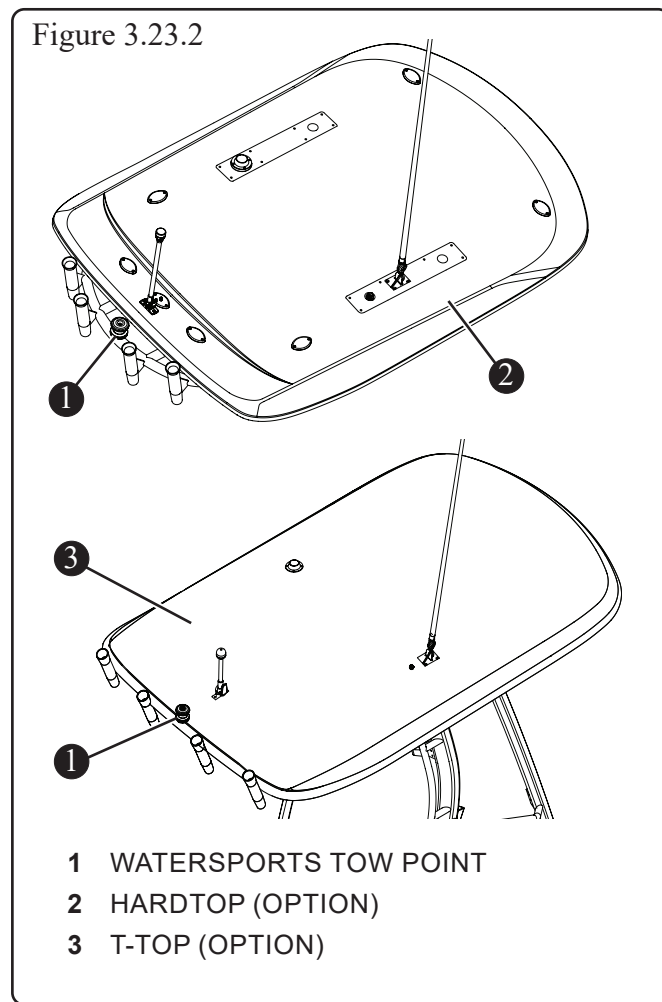

## All Activity Tower (Option)

### ⚠ WARNING

Do not use the topside platform for any activity when engine is running. Wait for propeller to completely stop before occupying the platform.

### ⚠ CAUTION

Do not use watersports tow point with any equipment tied to the tow rope.

The large topside platform provides solid non-skid footing for fishing or poling this vessel through shallow water (see Figure 3.23.1).

The all activity tower includes an integrated watersports tow point used for skiing or wakeboarding only (see Figure 3.23.1). If engaged in tubing or such other recreational towing, attach the tow rope to the stern eyes at the transom (see Figure 3.23.2). Read and understand the safety rules for recreational activities in Chapter 1, *Safety*.

All Activity Tower (Option)  
Fig. 3.24.1

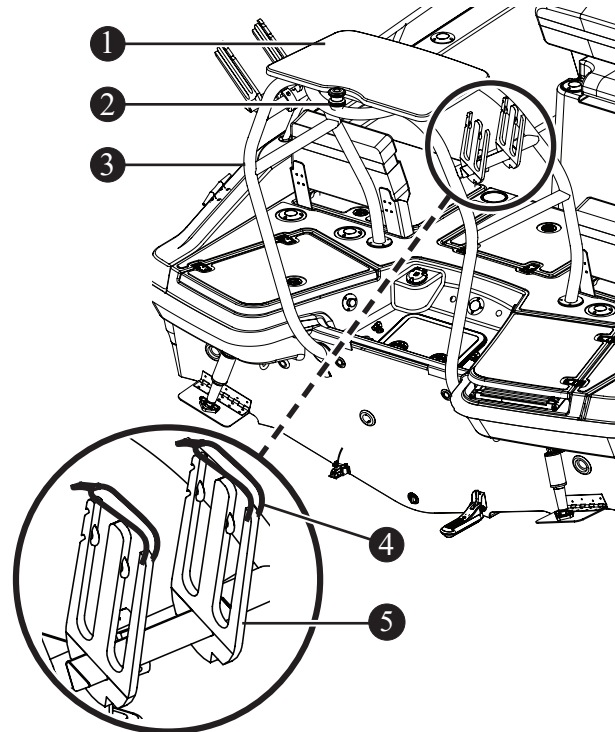

- 1 TOPSIDE PLATFORM
- 2 WATERSPORTS TOW POINT
- 3 ALL ACTIVITY TOWER
- 4 WAKEBOARD RACKS
- 5 SECURING STRAP

Stern Eyes  
Figure 3.24.2

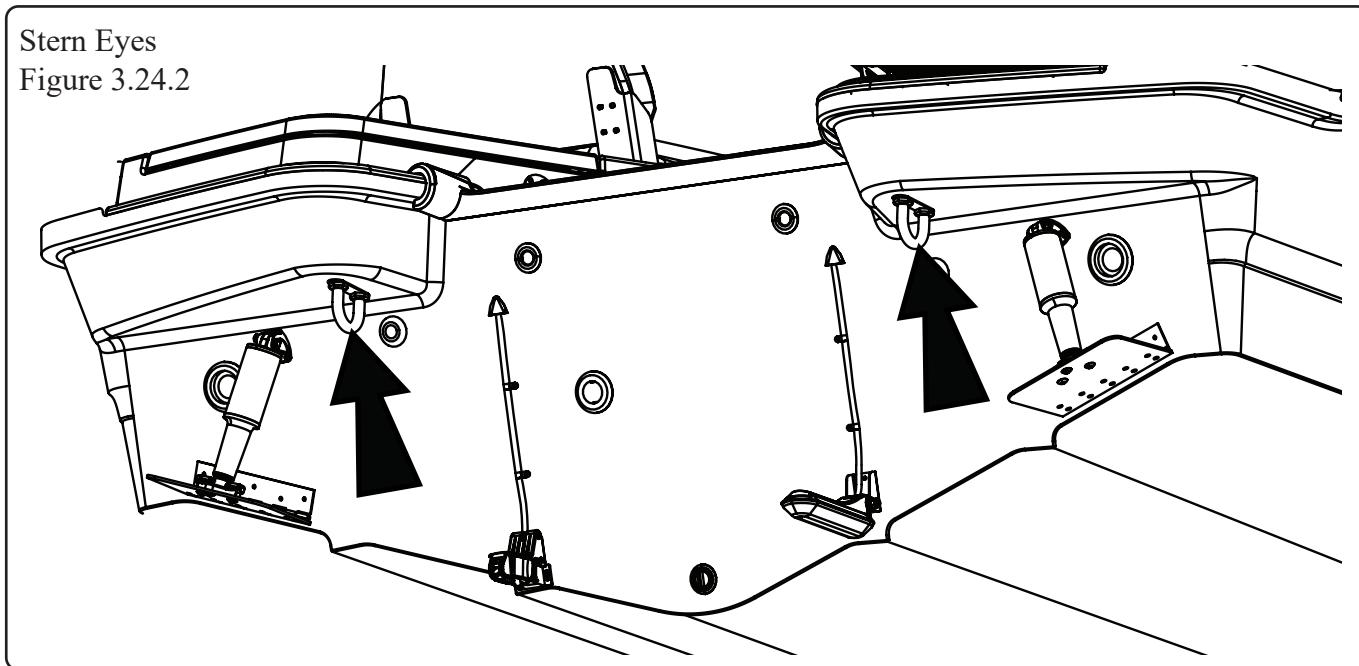

Seating

Seating  
Figure 3.25.1

**NOTICE**

Always wash metallic parts with soap and water and rinse with freshwater. Once dry, apply a light coating of lubricant to protect moving parts. Check for loose or damaged hardware and tighten or replace as necessary.

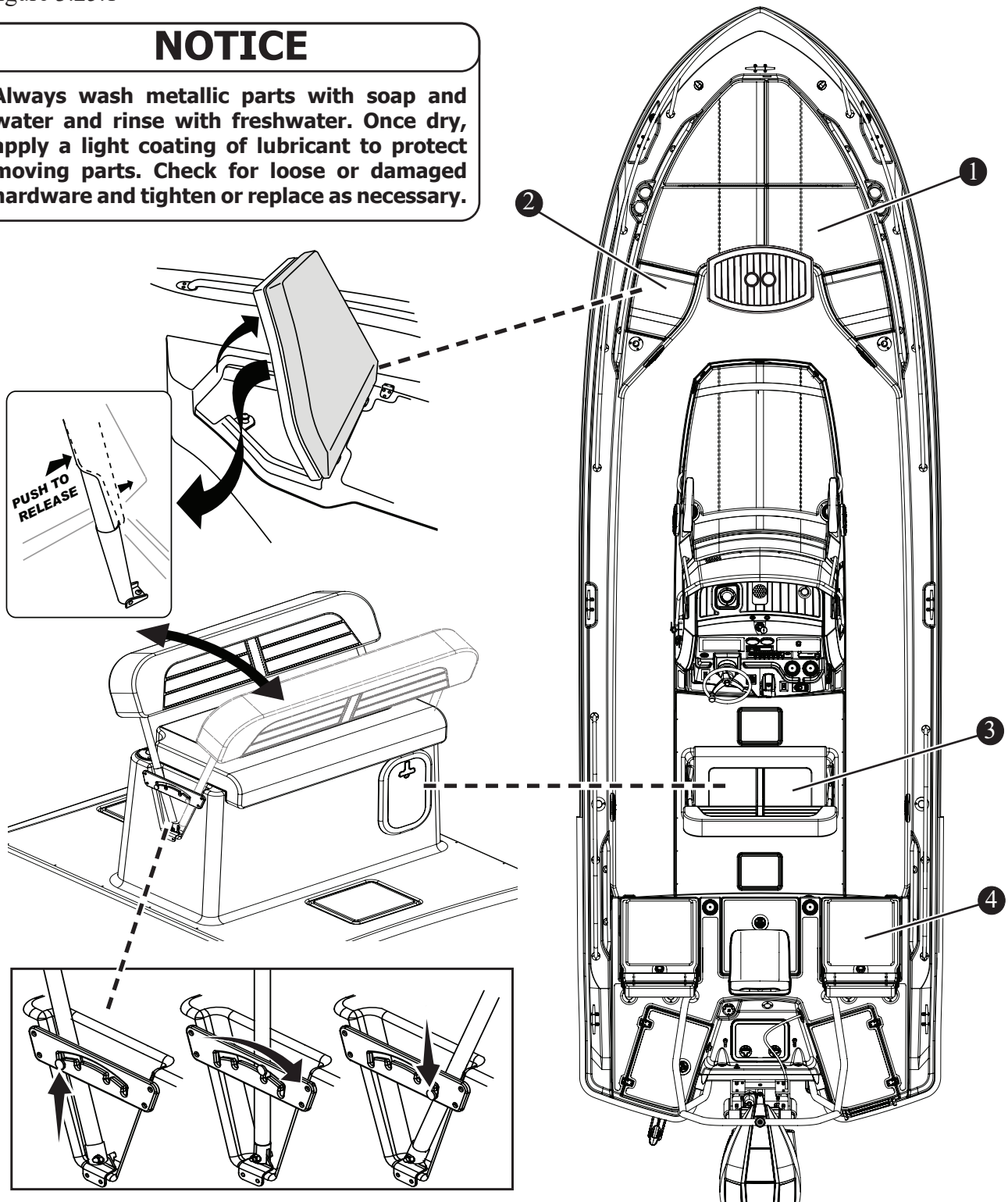

- 1 BOW SEATING AREA
- 2 FOLDING BACKREST

- 3 HELM SEAT
- 4 STERN SEAT WITH FOLDING BACKREST



## Seat Conversion to Fishing Platform

The dual stern seats can be converted to a walk-on fishing platform (see Figures 3.25.1 and 3.26.1).

Stern Seats  
Figure 3.26.1

- 1 BACKREST
- 2 HINGED SEAT BASE
- 3 SEAT LATCH
- 4 SEAT CUSHION
- 5 SNAP FLAP
- 6 SNAPS
- 7 MESH
- 8 MAGNETS

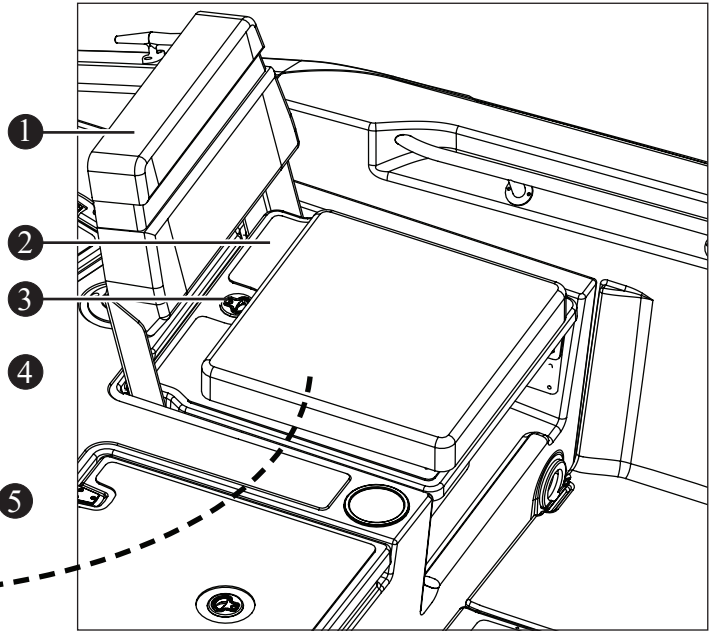
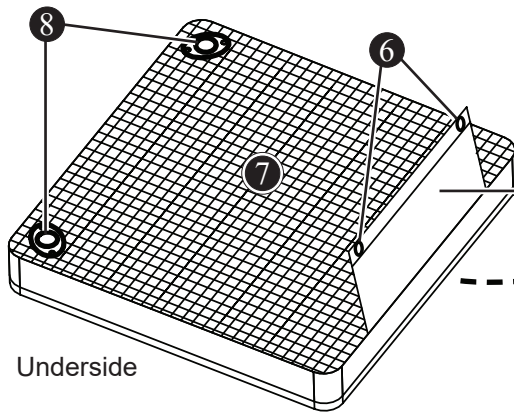

1. Start Position

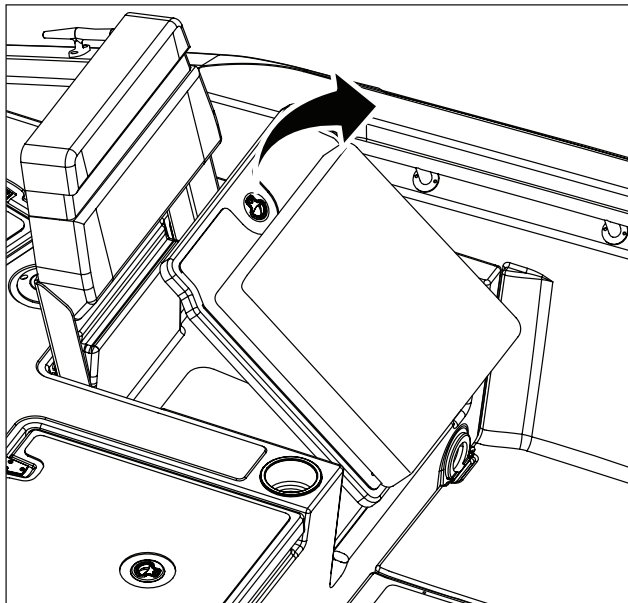

2. Raise Seat  
Release seat latch and raise seat.

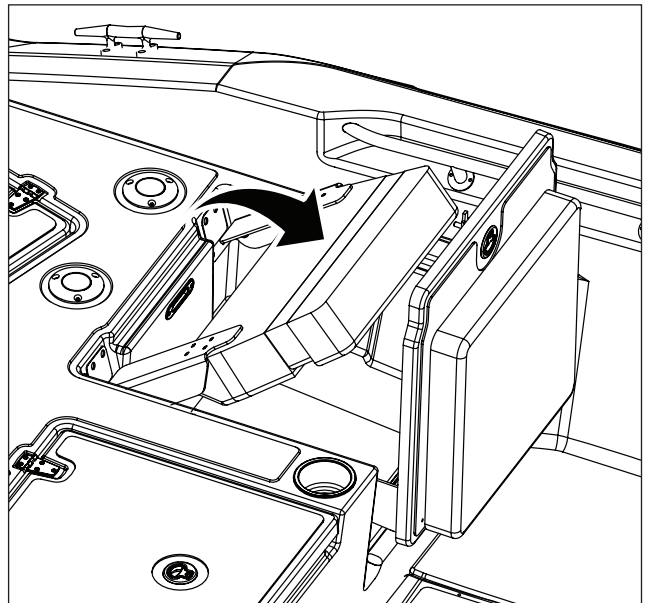

3. Lower Backrest  
Fold backrest down to stowed position.

Dual Stern Seats (Continued)  
Figure 3.27.1

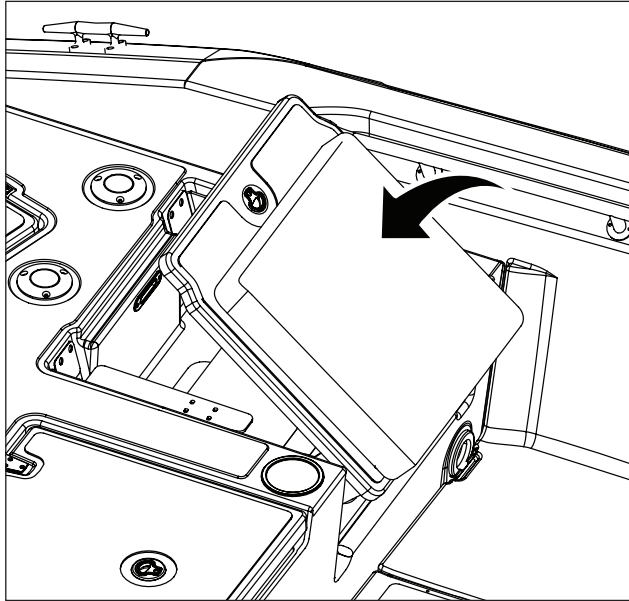

#### 4. Lower Seat

Fold seat down and latch it.

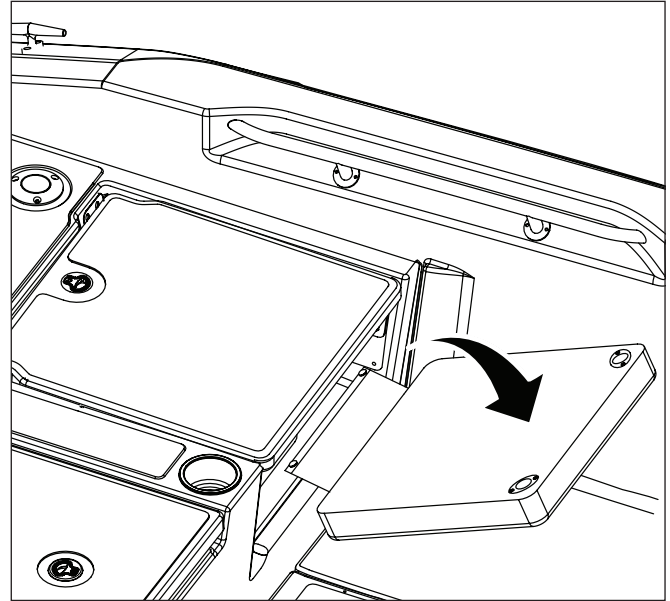

#### 5. Remove Cushion

Remove seat cushion (secured with magnets and snaps).

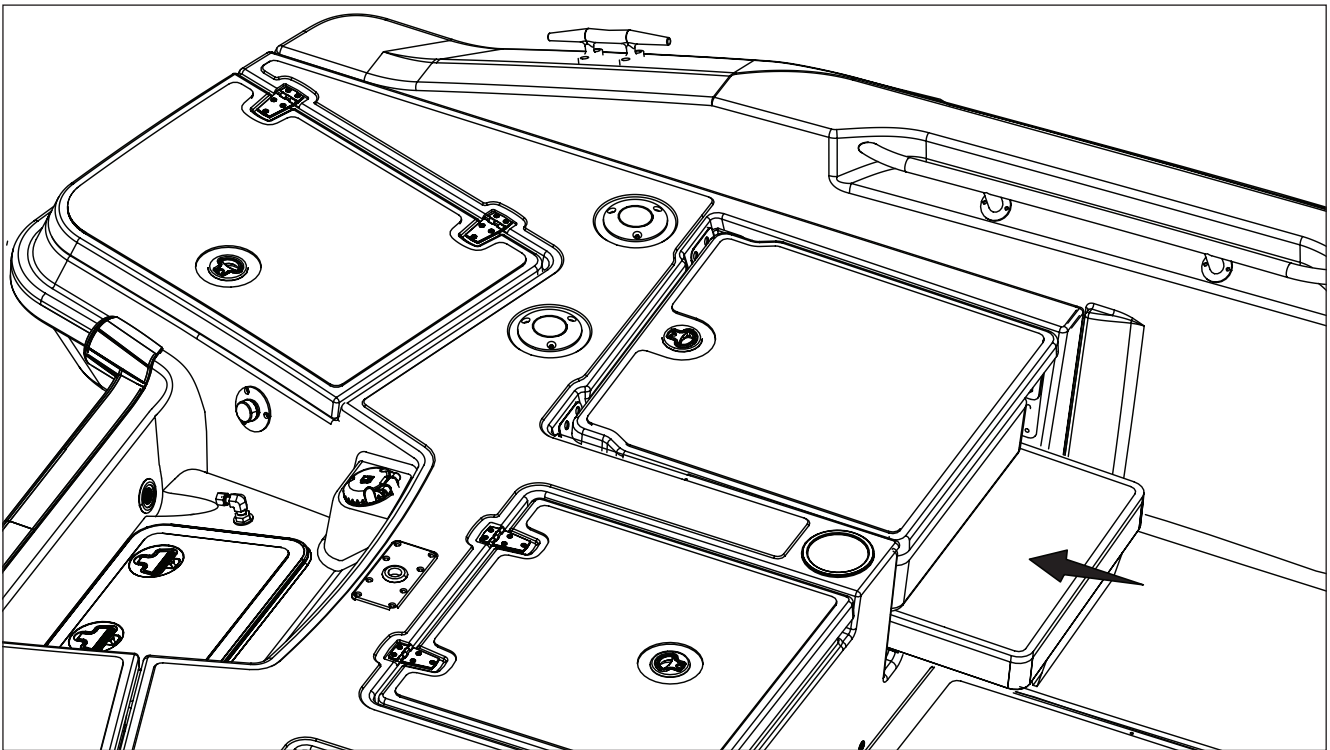

#### 6. Store Cushion

Tuck snap flap under cushion and insert in storage slot as shown. Mesh side down and magnets aft.

Pedestal Fishing Seats  
Figure 3.28.1

**! WARNING**  
Avoid serious or fatal injury. Do not occupy seat when speed exceeds 5 mph.

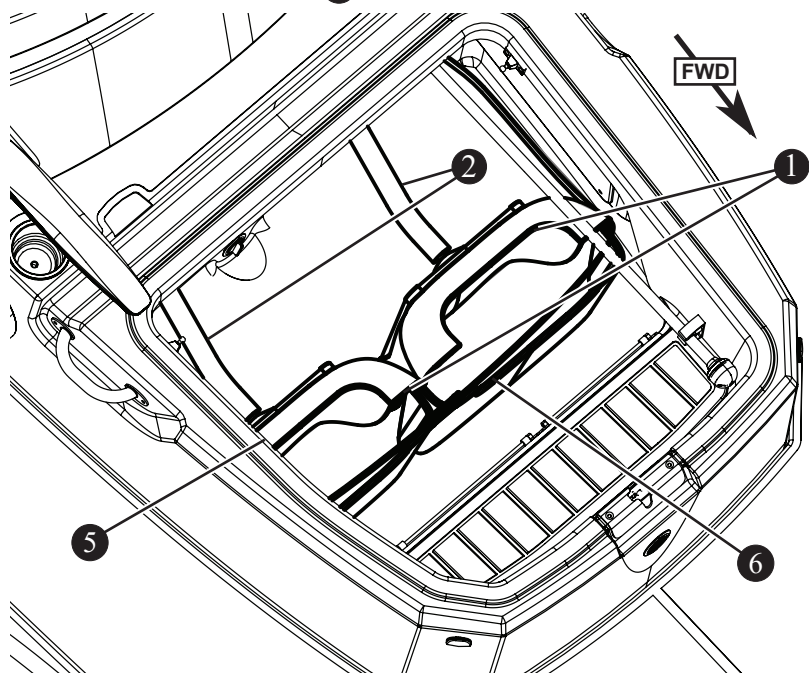
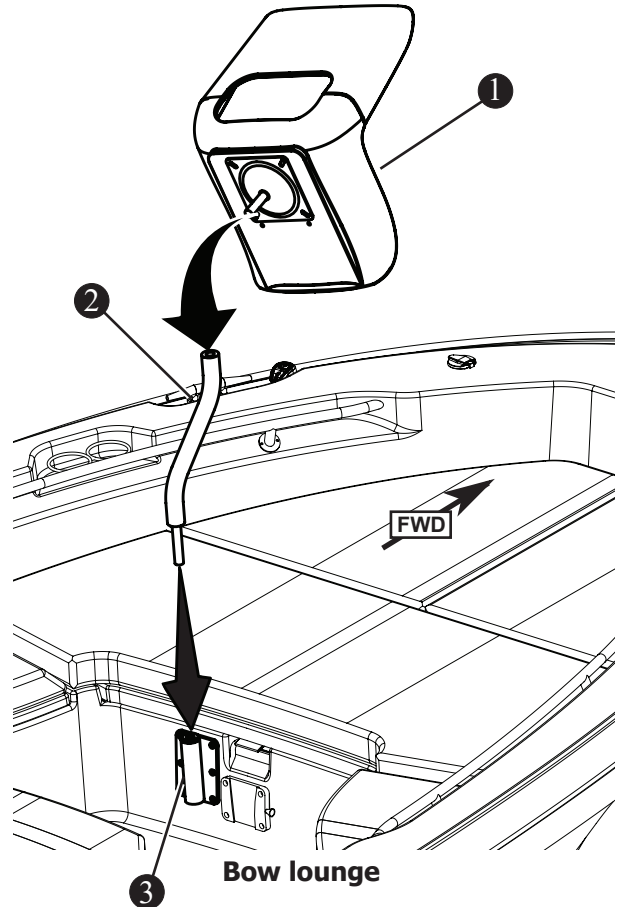
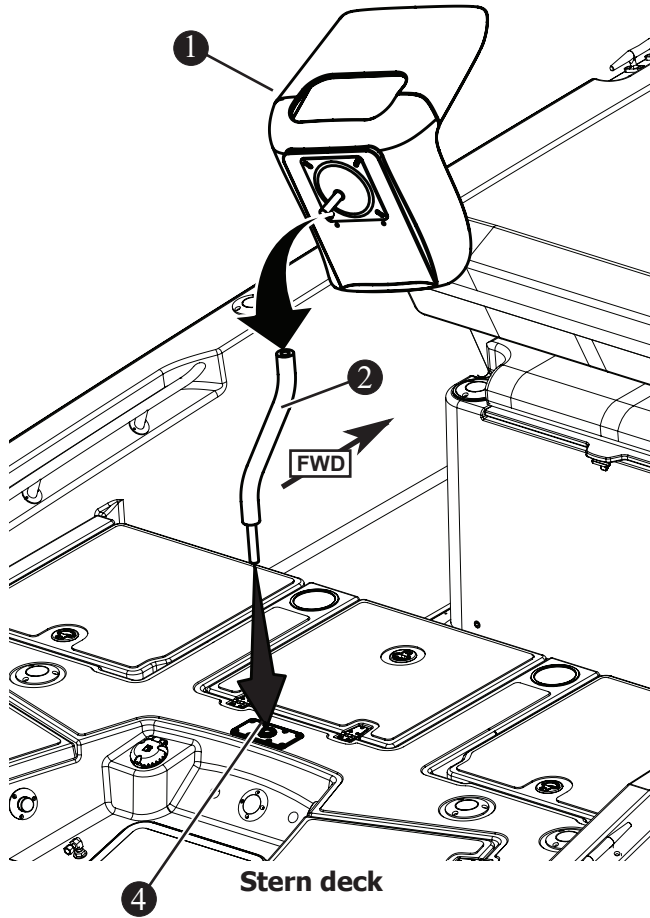

- 1 FISHING SEAT
- 2 PEDESTAL
- 3 FORWARD BASE
- 4 AFT BASE
- 5 CONSOLE LOUNGE STORAGE
- 6 HOLD DOWN STRAP

### Entertainment System (Option)

The entertainment system consists of a stereo radio, waterproof speakers, remote controls, and USB input. The bluetooth-enabled stereo is located at the helm. One remote control is located in the starboard gunwale forward of the console. Another remote control is located in the owners packet. Control volume and menu functions with the remote or the stereo.

Also available is the premium audio which adds two subwoofers and an external amplifier.

REFER TO THE OWNER'S PACKET FOR COMPLETE INSTRUCTIONS AND WARRANTY INFORMATION.

### Air Compressor (Option)

This vessel can be equipped with a high-volume air compressor with tapered adapter to fit valves up to 1-1/4" diameter. This is used for inflating and deflating inflatables and delivers 20 cu.

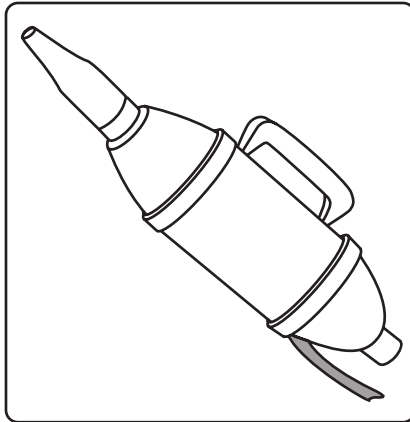

ft./minute. The unit has a 10-foot electrical cord that plugs into a 12V receptacle. A carrying/holding case is provided so it can sit flat on the floor of any of the storage compartments.

### Anchoring

#### **WARNING**

**Swamping hazard - Anchor from the bow if using one anchor. A small current can make a stern-anchored boat unsteady. A heavy current can drag a stern anchored boat underwater.**

**Collision hazard - Anchor only in areas where the boat will not disrupt other boats. Do not anchor in a channel or tie up to navigational aids as it is both dangerous and illegal.**

#### **WARNING**

**Keep hands, feet, hair and loose clothing clear of moving parts (anchor, rode, etc.). Entanglement may cause severe bodily injury.**

#### **CAUTION**

**Be careful trailing lines do not foul the propeller.**

#### **NOTICE**

**Before using the anchor be sure the anchor line is securely attached to the eye in the bottom of the anchor locker and to the anchor itself.**

### Anchoring

To anchor, turn bow into the wind or current and put the engine in neutral. When the boat comes to a stop, lower the anchor from the bow (see Figure 3.29.1). Proper anchoring requires knowledge of rode and scope and understanding the relationship between rode, scope and anchor performance.

**Rode:** The rode is the line connecting the anchor to the boat. Nylon line is ideal because it is light, strong and stretches, it also can be stored wet and is easy to handle. Add a length of chain between the anchor and the nylon line to help set the anchor more easily.

**Scope:** The scope is defined as the ratio of rode length to the vertical distance from the bow to the sea floor. Scope also depends on the type of anchor, tides, winds, sea conditions and type of sea floor the anchor is in. To determine how much rode to use when anchoring, use this common formula: Rode length = (bow height + water depth) × scope

The minimum is 5:1 for calm conditions; normal is 7:1, and severe conditions may require 10:1.

#### **Example:**

Rode length = (3 feet + 10 feet) × 7\*

Rode length = 13 feet × 7\*

Rode length = 91 feet

### Considerations

Wind and sea conditions can affect the boat. Because the boat is not moving through the water, there is no control. Be sure that the anchor will hold under all circumstances if you are leaving the boat. Understand the principles of rode and scope and their effect on anchor performance. Because there are a variety of anchors with different uses, discuss with your dealer the right anchor for this vessel.

\* Scope may range from 5 to 10 or more. However, less than 5, the anchor will break out too easily.

### CAUTION

**To avoid property damage, engage gypsy lock and ensure anchor is secured with lanyard before getting underway.**

### NOTICE

**Turn on anchor light when at anchor or drifting (not under power) at night or in low visibility.**

REFER TO THE OWNER'S PACKET FOR COMPLETE INSTRUCTIONS AND WARRANTY INFORMATION.

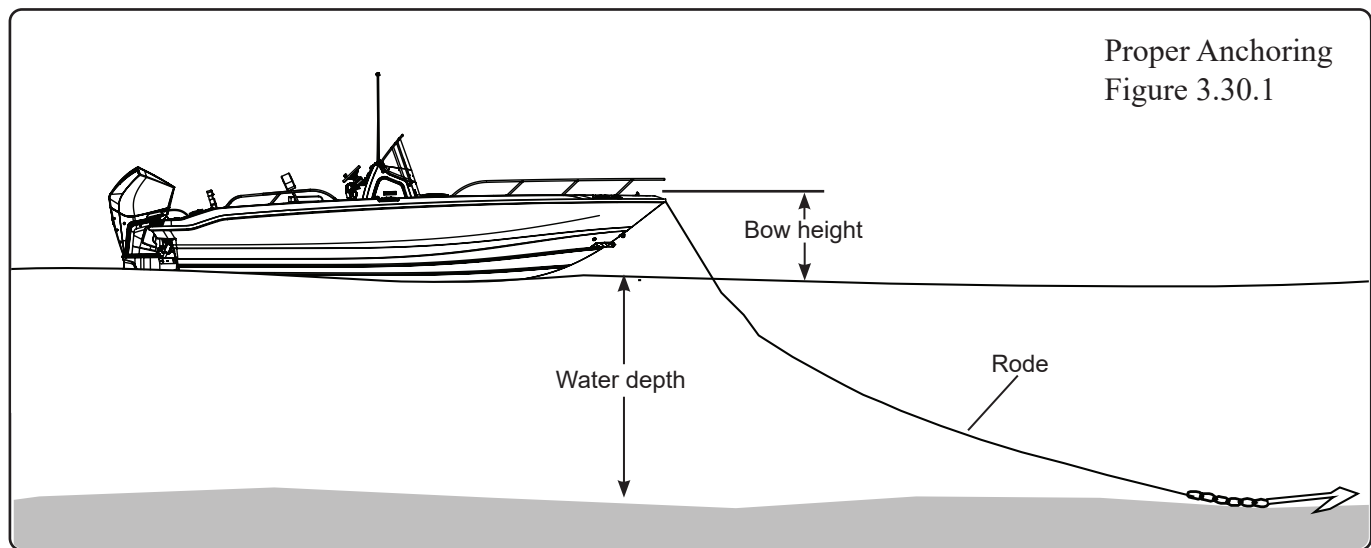

$$\text{Rode length} = (\text{bow height} + \text{water depth}) \times \text{scope}$$

### Lowering the Anchor

- Be sure there is adequate rode.
- Stop completely before lowering the anchor.
- Secure rode to both the anchor and the boat.
- Keep feet clear of lines.

### Setting the Anchor

There is no ideal way to set an anchor. Experiment to see how it performs. One method is to turn the rode around a bitt or a cleat and slowly pay out as the boat backs from the anchor site. When the proper scope has been reached snub the rode quickly, causing the anchor to dig in to the sea bottom.

- Reverse the engine slowly to drive the anchor in and to prevent it from dragging
- Secure the rode to a bitt or cleat

### Weighing the Anchor

To weigh or retrieve the anchor, start the boat and run slowly up to the anchor, taking up the rode as you go. The anchor will usually break out when the rode becomes vertical. Coil lines to let them dry before stowing. The bow storage compartment located in the starboard bow should be used to stow the anchor line.

### Anchor Roller (Option)

The anchor roller allows to deploy or retrieve the anchor rode without damage to the rub rail or other equipment on the boat.

Anchor Roller (Option)  
Figure 3.31.1

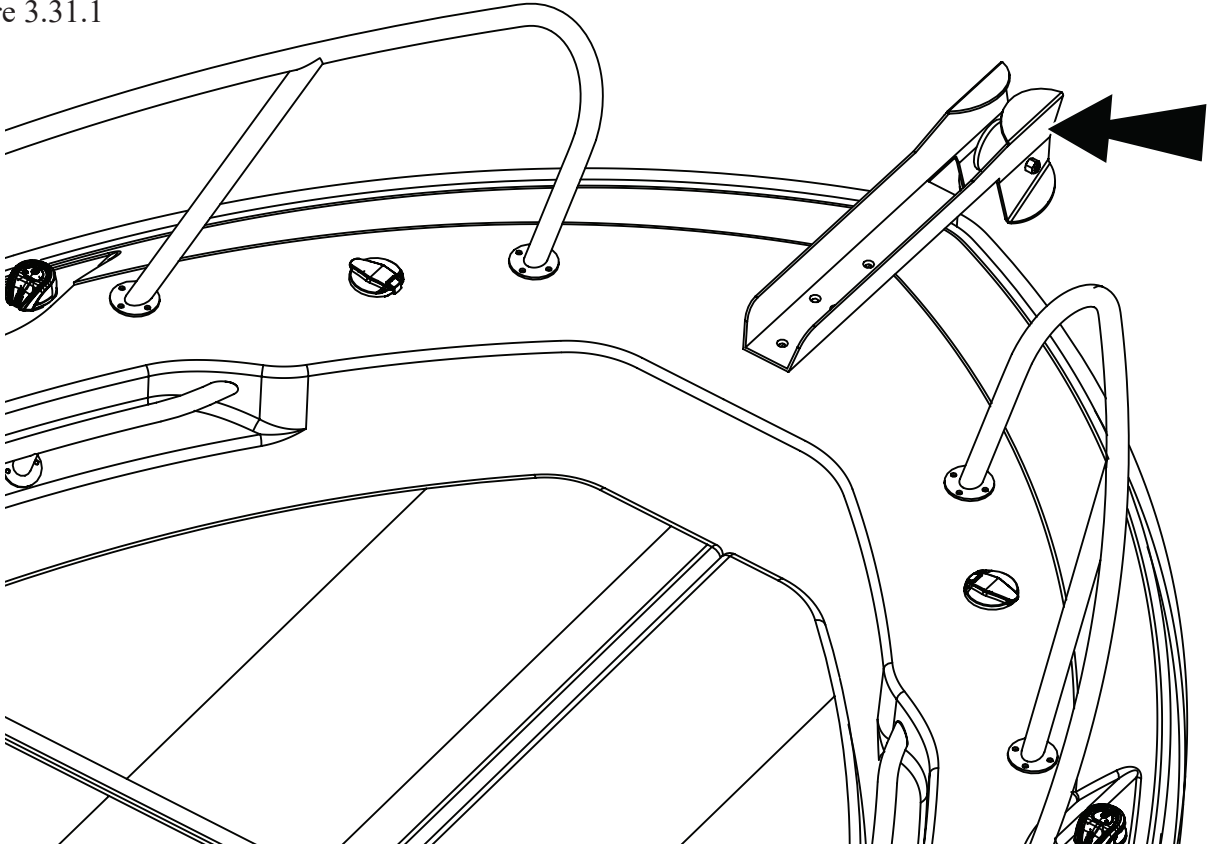

### Bow Shade (Option)

Figure 3.32.1

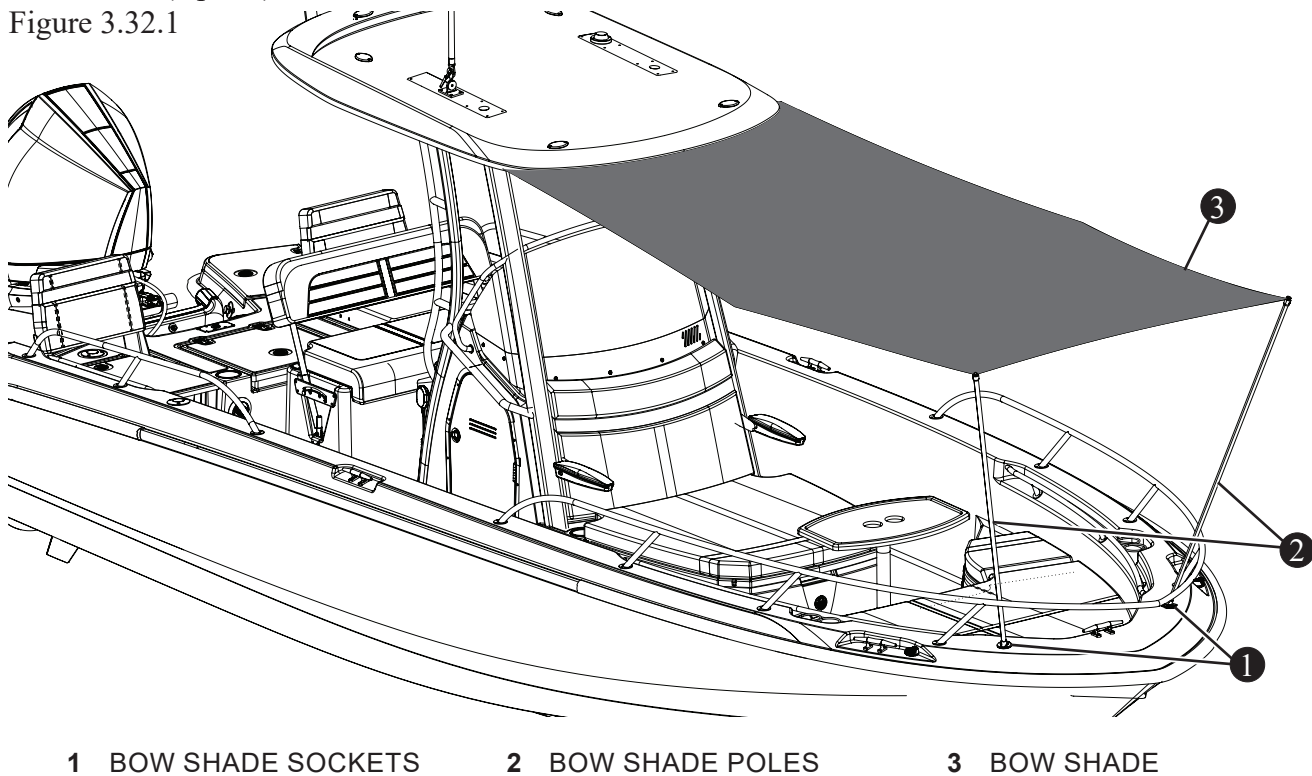

### WARNING

Bow shade is intended for use while boat is anchored or moored - not while underway. Obstruction of navigation sidelights, damage to boat or personal injury could occur if shade is used while underway.

### Bow Shade (Option)

If equipped, set up the shade as shown (see Figure 3.31.1):

1. Assemble four pole sections into two poles.
2. Insert the poles into bow shade sockets.
3. Attach the bow shade with the provided clips in these perspective locations on the bow poles and the hardtop or T-top.
4. Follow the canvas care instructions in chapter 5, *Care and Maintenance*.

### Towing, Docking, Lifting and Trailering

#### Towing

### WARNING

Towing or being towed places extreme tension on tow lines and strong points (cleats, bow stern/eyes). Do not stand directly in line with tow line. Serious injury or death and/or vessel damage may occur if towing gear fails.

If it becomes necessary to have this vessel towed, the U.S. Coast Guard or a private salvage company experienced in this type of operation are better equipped to perform this service. Only use another recreational boat as a last resort as doing so may cause damage to one or both boats due to operator inexperience or other conditions such as weather and/or current. The other boat may assist by standing by and keeping the disabled boat's bow at the proper angle until help arrives.

When towing is necessary, create a bridle with a line around the hull or use spring lines to secure the disabled vessel to the towing vessel (see Figure 3.32.1), whenever possible. Either of these methods distributes the load over a wide area. Be sure to use fenders or other chafe protection at pressure points.

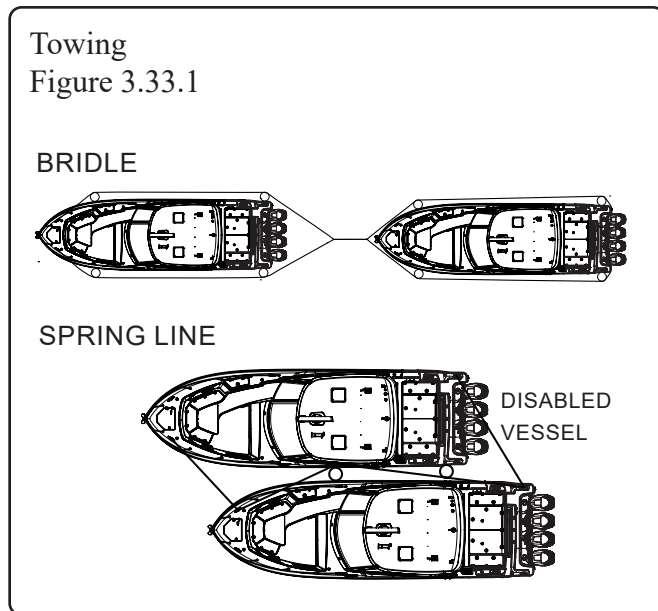

The standard bow eye, reinforced with a backing plate (see Figure 3.32.2), is typically used to haul out and hold this vessel on a trailer.

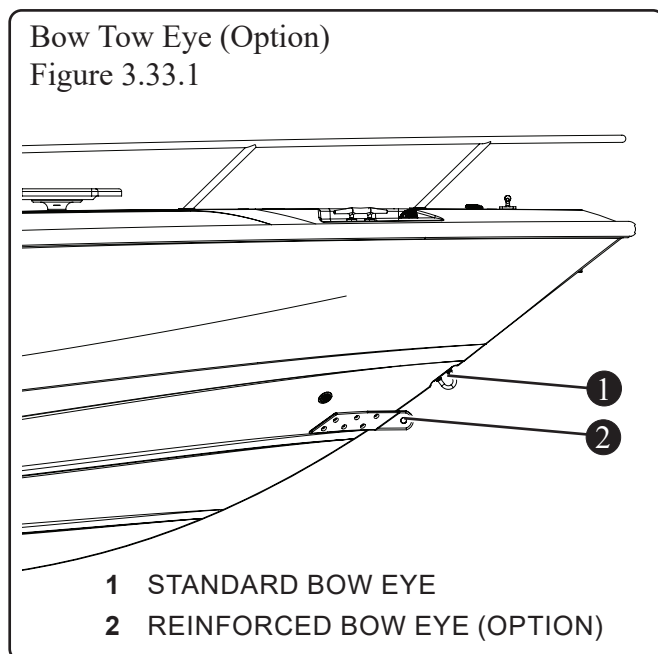

Before operating with a boat in tow, seek professional advice and/or training (e.g., USCG Auxiliary, US Power Squadrons, or BoatUS) to master towing

fundamentals. While operating with a boat in tow there are several regulations and guidelines that must be followed:

- Display the proper markings and navigation lights on towing vessel and disabled vessel.
- Disabled vessel should never be larger or heavier than towing vessel.
- Ensure all tow lines/bridle are adequately sized and in good condition.
- Only secure tow lines to strong points designed for towing (bow/stern eyes, reinforced cleats).
- Designate experienced crew to monitor, identify, and manage risks.
- Always monitor WhalerWatch while towing, when installed.
- While underway, be prepared to adjust tow line length and speed to meet current conditions.

### Docking

This vessel has seven cleats to use for tying up to a dock, three located at the bow, two located midship, and two located at the stern (see Figure 3.32.2). While loading/unloading or mooring, learn the proper way to secure the boat and how best to use the boat's mooring points. Figure 3.32.3 shows the correct method for tying a belaying knot, commonly used to secure a boat to a dock. This knot holds fast and is simple to release when needed.

### Lifting

The bow eye is used to haul out this vessel out of the water onto a trailer and hold it there. The stern eyes are used as tie down points while trailering. The bow and stern eyes may be used only for short-term lifting of the boat such as servicing (see Figure 3.33.1). For long-term lifting or storage, use flat, wide belt-type slings and spreaders long enough to keep pressure from gunwales. Do not allow slings to contact underwater fittings.

### Bow Tow Eye (Option)

The optional bow tow eye, which is located on the front hull of the boat, is reinforced with a steel-backing plate (see Figure 3.32.2).



Cleat Locations  
Figure 3.34.2

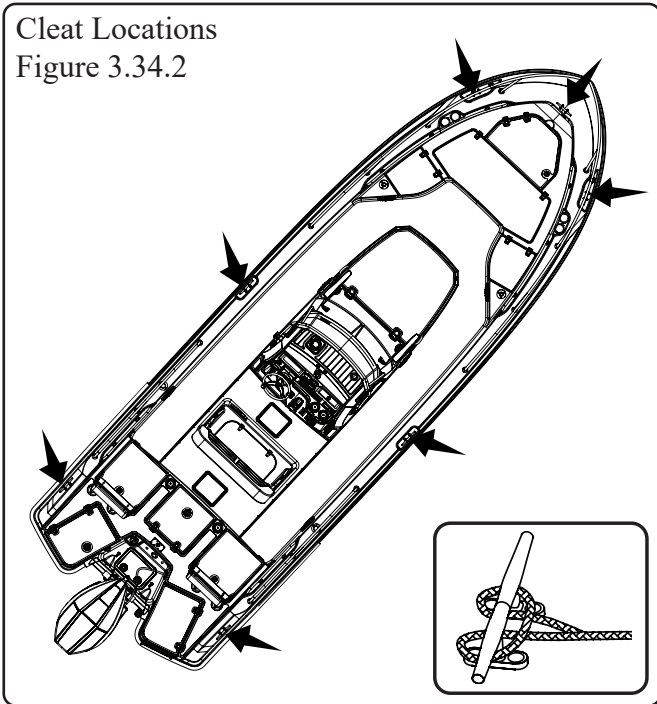

Belaying Knot  
Figure 3.34.3

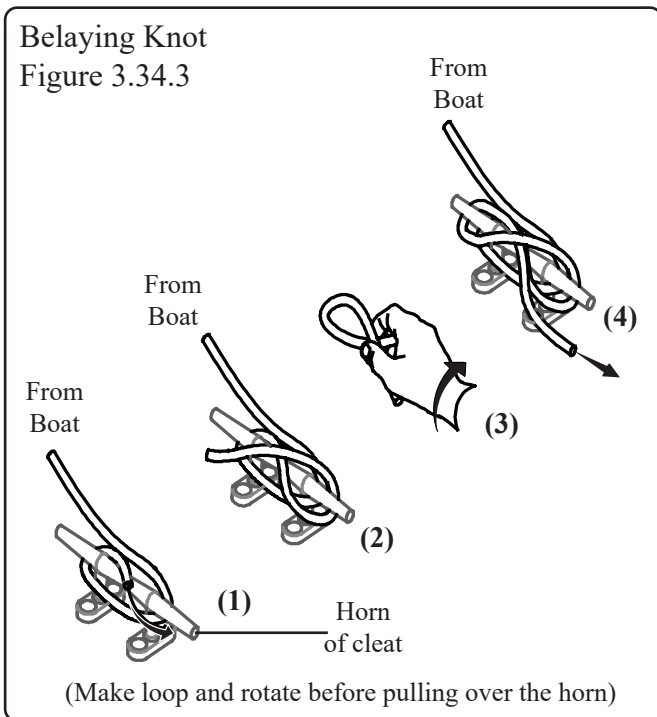

## ⚠ DANGER

Use only the lifting points specified. Using the cleats for lifting is dangerous and could cause serious injury or death.

## ⚠ CAUTION

Long-term lifting with the bow and stern eyes can cause stress on the fiberglass and gel coat and is not recommended.

Short-term Lifting  
Figure 3.34.3

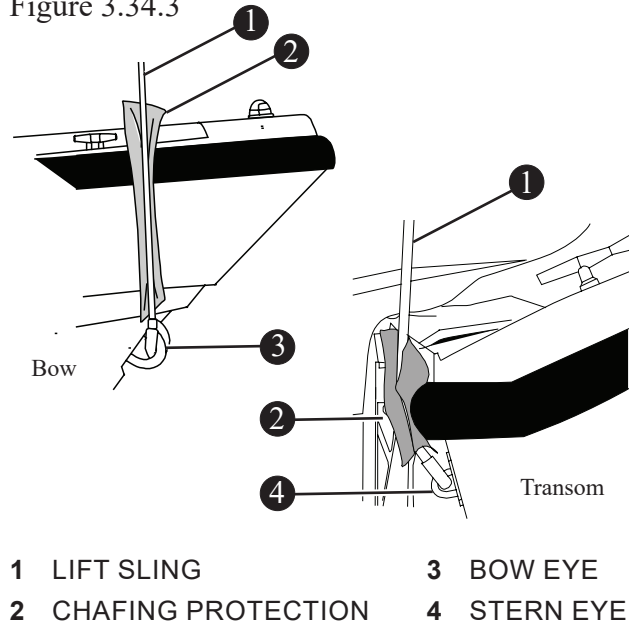

Whether lifting this vessel out of the water for routine maintenance or long-term storage, consider the following:

- If using a professional lifting service, check all credentials and ask for proof of insurance.
- Use a wide, flat, belt-type sling for lifting to minimize stress on the gunwales. Careful location of the sling is required. Sling labels are installed at four spots on the gunwale that should be used as a guide for sling placements.
- If using a lifting hook, attach to bow and stern lifting eyes.
- Use a spreader bar on the stern eyes and use chafing protection on the top of the transom.

- All drain plugs (transom, livewell, deck, etc.) should be pulled out and the boat positioned with the bow slightly higher than the stern so water that has accumulated in the cockpit and/or bilge can be easily drained.

### Trailer

#### NOTICE

The warranty may be void if a trailer with rollers is used. Use a trailer with bunks only.

This vessel has the option of being fitted with an aluminum trailer which is best suited to the boat's length and width. If a trailer is not provided by Boston Whaler, then the following design considerations must be followed to not void your structural hull warranty:

- Trailers equipped with rollers can damage the hull of this vessel and should never be used to support the hull bottom.
- A single roller at the *WINCH STAND/ASSEMBLY* (see Figure 3.36.1).
- The hull bottom must be supported solely by a fixed *BUNK STYLE ASSEMBLY* (see Figure 3.36.1).

### Securing Boat to Trailer

#### Bow Eye Safety Chain/Cable

There is a safety chain/cable that attaches to the bow eye and will keep the boat from sliding off the trailer in the event that the winch strap or cable breaks. Hook this up first.

#### Tie-Down Straps

Can be used to secure the boat from the stern. The tie-down straps hook into the tie-down loops on the trailer frame and to the stern eyes on the transom. Padding (or similar) chafe protection should be used wherever the tie-down straps come in contact with the hull.

### Securing Trailer to Tow Vehicle

#### ⚠ DANGER

Never use only tie down straps as they are only used to help keep boat secured to the trailer. Make certain that the safety chain is properly secured to the bow eye.

#### ⚠ CAUTION

Never use improperly matched hitch ball and coupler. Do not secure chains to bumper of tow vehicle.

### Vehicle Safety Chains/Cables

Safety chains/cables (see Figure 3.36.1) are connected to the trailer and should be of sufficient length to reach the frame of the tow vehicle and should be long enough to allow the tow vehicle to turn without binding or tensioning.

#### Trailer Hitch

A properly matched trailer hitch ball and coupler is important. Ensure the coupler and the hitch ball are properly seated and locked.

### Engine Trailing

#### ⚠ CAUTION

Do not rely on power trim/tilt system or tilt support lever on the outboard to maintain proper ground clearance for trailering. The outboard tilt support lever is not intended to support the outboard for trailering.

Trail the boat with the outboard tilted down in a vertical operating position. However, if additional road clearance is required due to railroad crossings, driveway clearance, trailer bounce, etc., the outboard should be tilted up and supported using an accessory outboard support device. Consult a Boston Whaler dealer for engine support recommendations.

REFER TO ENGINE MANUFACTURER'S MANUAL IN OWNER'S PACKET FOR COMPLETE INSTRUCTIONS AND WARRANTY INFORMATION.

Bunk Trailer  
Figure 3.36.1

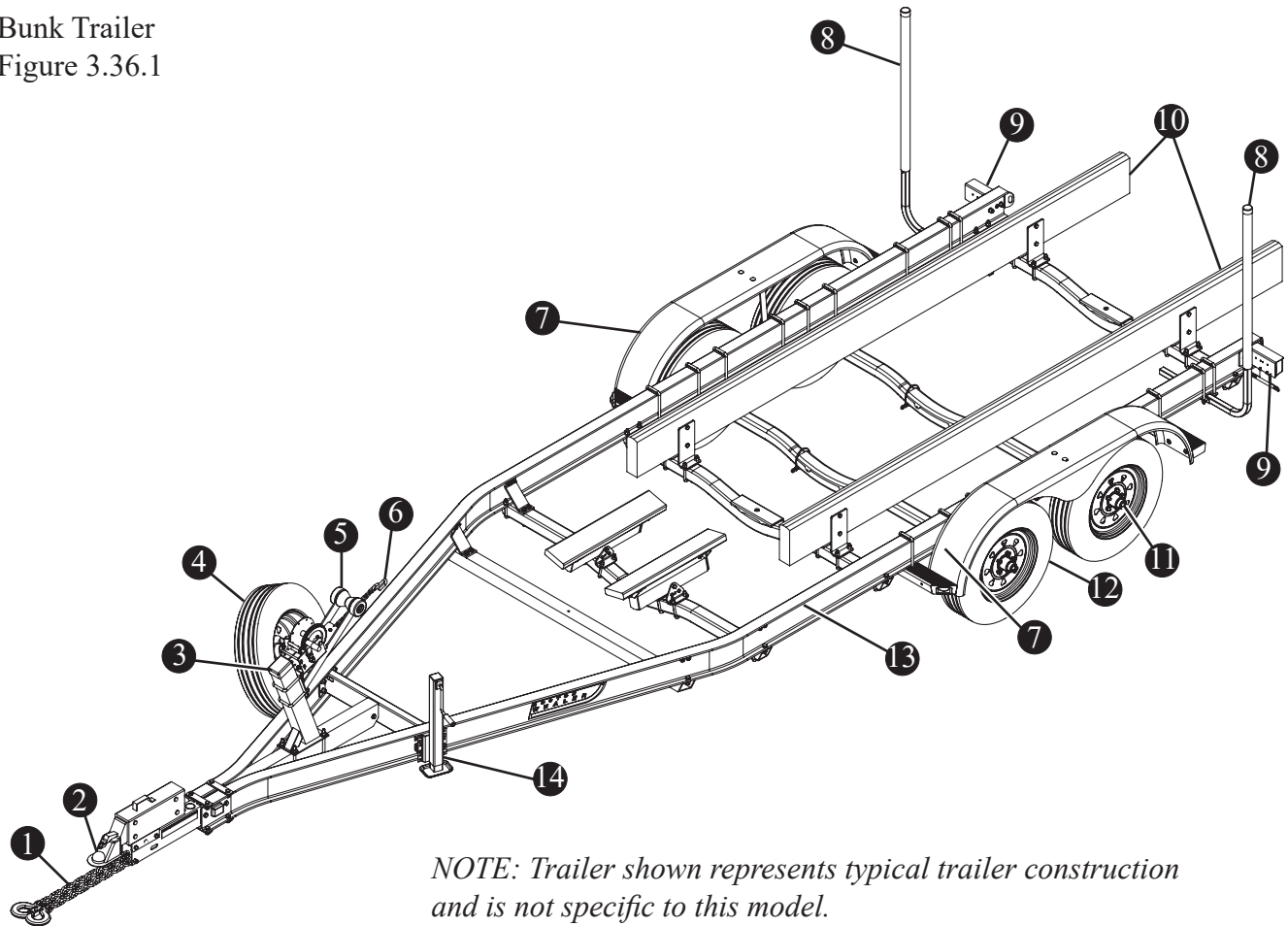

*NOTE: Trailer shown represents typical trailer construction and is not specific to this model.*

- |                        |                  |
|------------------------|------------------|
| 1 SAFETY CHAINS        | 8 GUIDEPOST      |
| 2 TONGUE/BALL HITCH    | 9 TAILLIGHT      |
| 3 WINCH STAND/ASSEMBLY | 10 BUNK ASSEMBLY |
| 4 SPARE TIRE           | 11 DUAL AXLES    |
| 5 CABLE ROLLER         | 12 RADIAL TIRES  |
| 6 WINCH HOOK/CABLE     | 13 TRAILER FRAME |
| 7 FENDER WITH STEP     | 14 TONGUE JACK   |

## DC Electrical System

This vessel's electrical system is powered by a series of batteries. The batteries are charged by the engine when running.

Battery power is used for engine ignition and trim/tilt systems, helm switch panel, lighting/navigation, livewell, freshwater system, raw water, and stereo system.

## Batteries

### ⚠ DANGER

**Batteries contain hazardous substances which can cause serious injury. Avoid contact with skin, eyes, and clothing. If contact occurs, immediately flush with large quantities of water and obtain medical assistance.**

### NOTICE

**Always store the batteries in the battery trays. Use the retaining bracket and nylon lock nuts to keep the batteries secure while underway.**

REFER TO ENGINE MANUFACTURER'S MANUAL IN OWNER'S PACKET FOR COMPLETE INSTRUCTIONS AND WARRANTY INFORMATION.

The following table is for reference purposes only. Use only AGM batteries with Verado engines.

Application	Group	Volts	MCA*	RC 25	Qty.**
USA (SAE)	31	12	800	135 min	2

\* Marine Cranking Amps

\*\* Trolling motor option adds three more batteries

Application	Group	Volts	CCA*	Reserve	Qty.**
Intrn'l (EN)	31	12	975	65Ah	2

\* Cold Cranking Amps

\*\* Trolling motor option adds three more batteries

### NOTICE

**Ensure that the batteries meet Mercury's AGM and CCA requirements**

## Battery Trays

Two batteries are located in the stern deck port and starboard access hatches (see Figure 4.1.1). If the trolling motor option is included, an additional three battery boxes are installed inside the console. Batteries should always be secured in the battery trays provided and secured in place by the retaining straps. The trays ensure that while underway the batteries do not move around, thus causing

damage to components fitted in the same area.

To remove battery, disconnect cable from negative terminal first, followed by positive cable; remove the retaining straps.

Batteries  
Figure 4.1.1

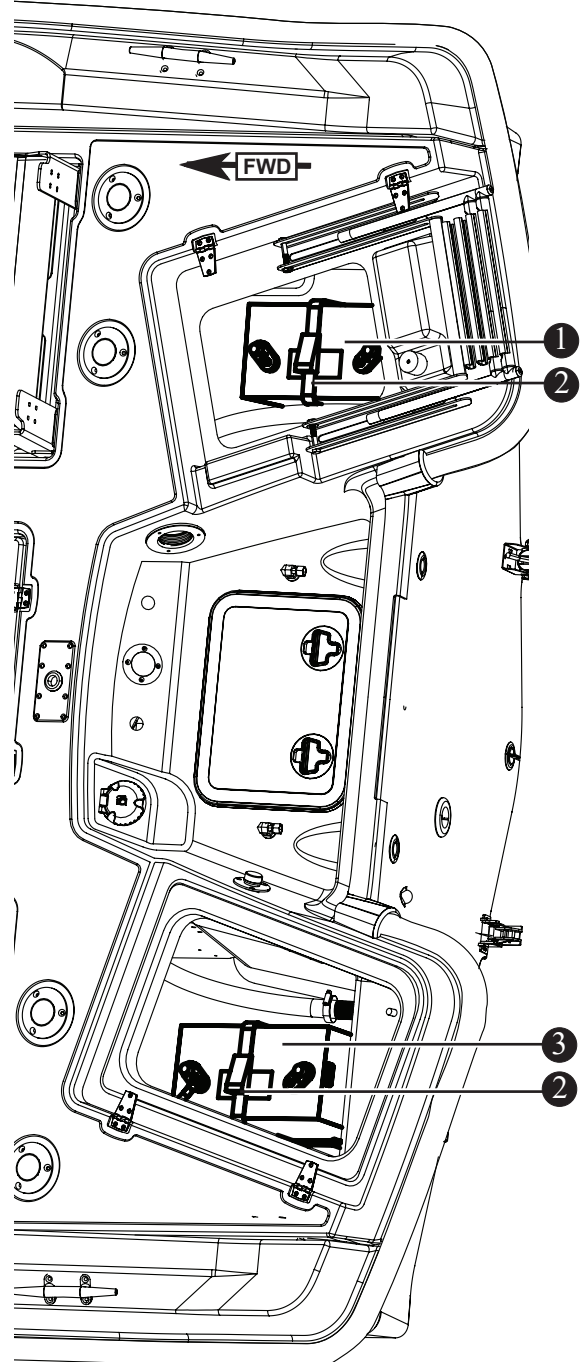

- 1 ENGINE BATTERY
- 2 RETAINING STRAP
- 3 HOUSE BATTERY

Trolling Motor Battery Boxes (Option)  
Figure 4.2.1

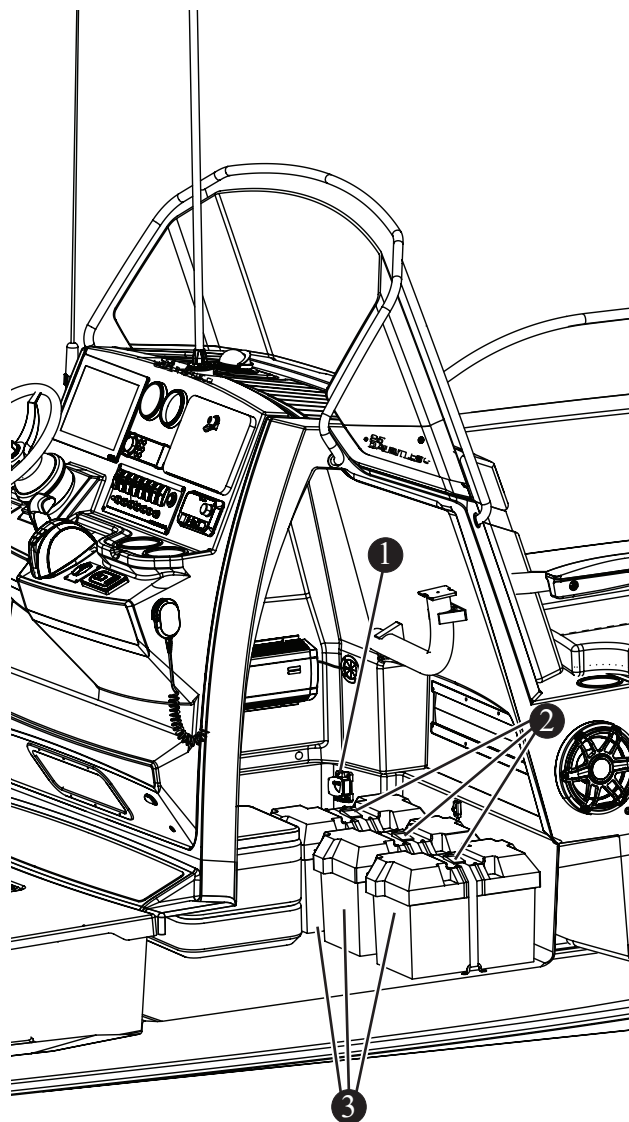

- 1 CIRCUIT BREAKER (70 AMP)
- 2 RETAINING STRAP
- 3 BATTERY BOX

### Battery Switch

This vessel uses one battery switch (see Figure 4.2.2), to control delivery of DC power from the house and engine batteries. The battery switch is located in the port aft deck access hatch. The battery switch settings are detailed in Figure 4.3.1.

Battery Switch  
Figure 4.2.2

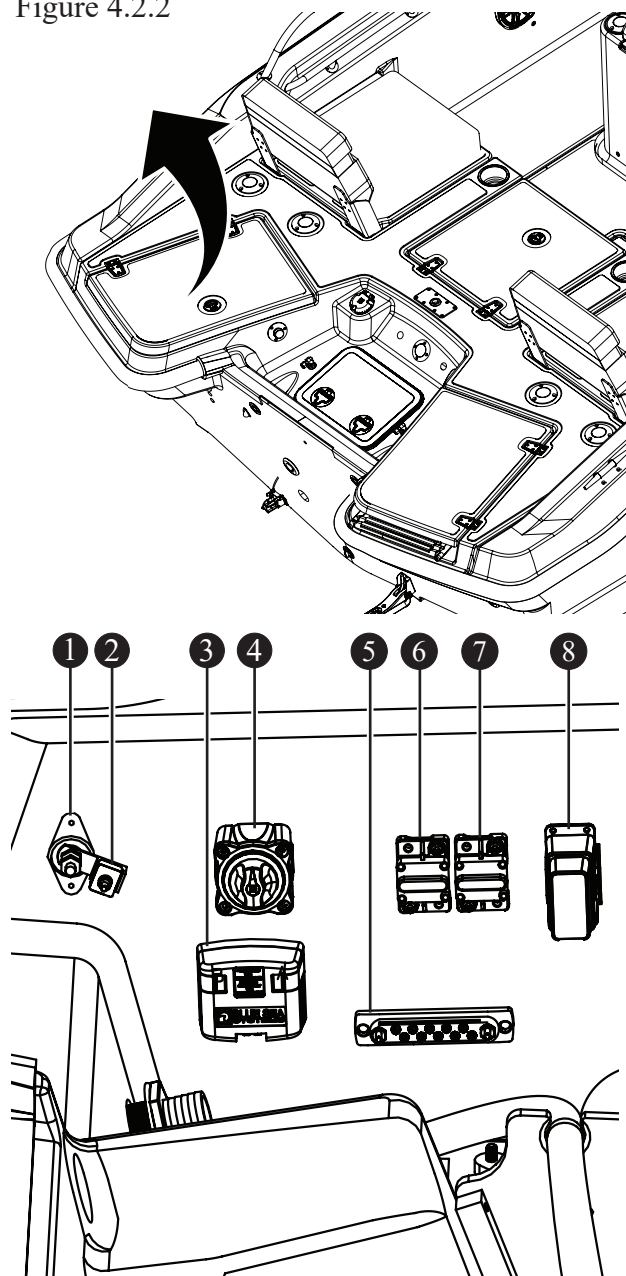

- 1 SINGLE POST POSITIVE BUS
- 2 TERMINAL FUSE (80 AMP)
- 3 AUTOMATIC CHARGING RELAY (ACR)
- 4 BATTERY SWITCH
- 5 NEGATIVE BUS
- 6 MAIN DC CIRCUIT BREAKER (80 AMP)
- 7 AMPLIFIER BREAKER (80 AMP) (OPTION)
- 8 BREAKER BOX, MAIN BILGE (5 AMP)
- 8 AUXILIARY BILGE (5 AMP) (CE OPTION)

## Battery Switch Settings Figure 4.3.1

*OFF* - No power to the house and engine systems.

*ON* - Power to the house and engine systems.

*COMBINE BATTERIES* - This parallels the engine and house batteries to assist with engine starting.

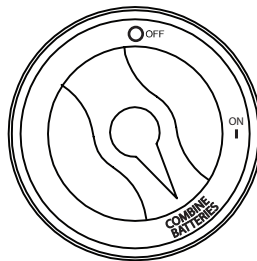
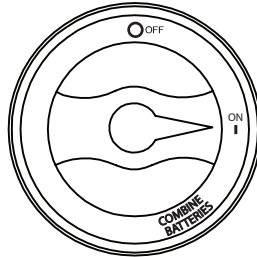
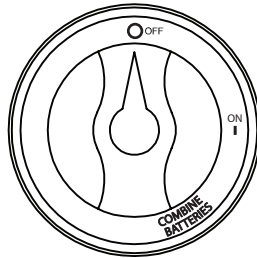

### **WARNING**

**Do not operate boat with batteries in combine batteries position once the engine is started or serious engine electrical damage may result.**

### **WARNING**

**Use the combine batteries position only if all batteries are near the same voltage. If one battery is strong and the others weak, high current could cause battery damage.**

## Automatic Charging Relay (ACR)

Batteries are automatically connected in parallel through the use of an automatic charging relay when a sufficient charging source is present. The battery banks are automatically separated when the charging source falls below a certain voltage level for a predetermined amount of time. The use of the automatic charging relay eliminates the need to monitor battery voltage and manually parallel the battery banks.

## Automatic Charging Relay (ACR) Figure 4.3.2

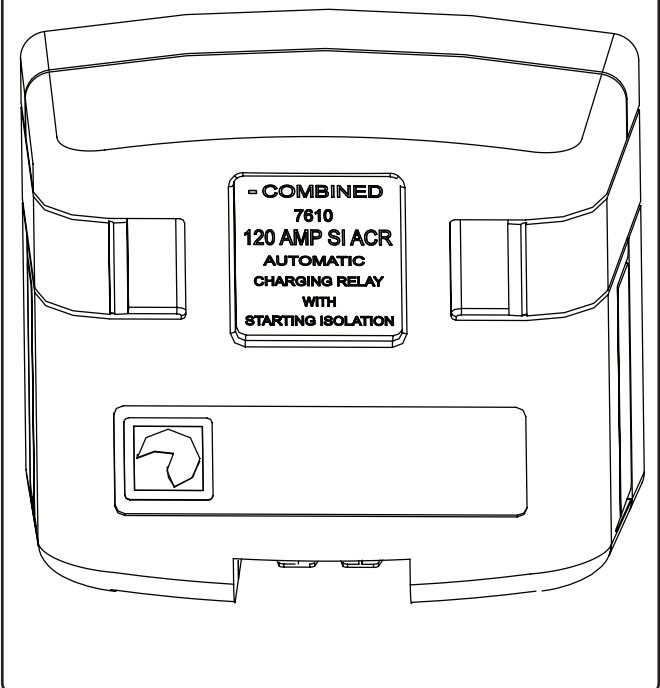

### Dockside Battery Charging (Option)

This vessel may be equipped with a battery charging system (see Figure 4.4.1). It is only available with the trolling motor option, and only charges the trolling motor batteries. Connect the extension cord to a ground fault circuit interrupter outlet to charge the batteries. Completely draining the batteries before recharging shortens battery life. If a battery remains discharged long enough it becomes impossible to charge. To maintain:

- Inspect the battery and charging system before use for loose connections or wiring.
- Coat the terminals with dielectric grease.
- Remove the batteries from the boat during cold weather or long term storage.
- Keep the batteries dry.

Battery Charging System (Option)  
Figure 4.4.1

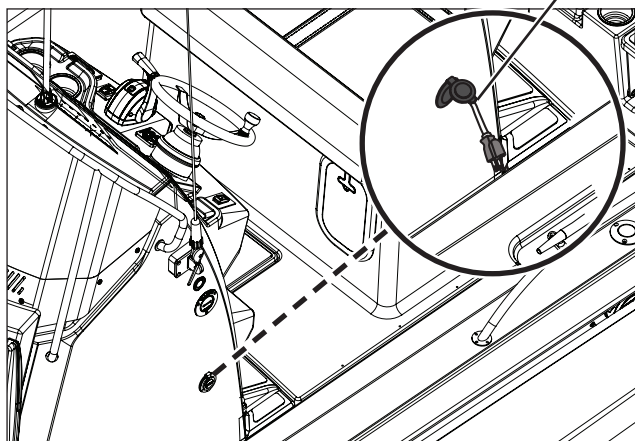

- 1 EXTENSION CORD
- 2 CONSOLE STORAGE (DOOR NOT SHOWN)
- 3 BATTERY CHARGER

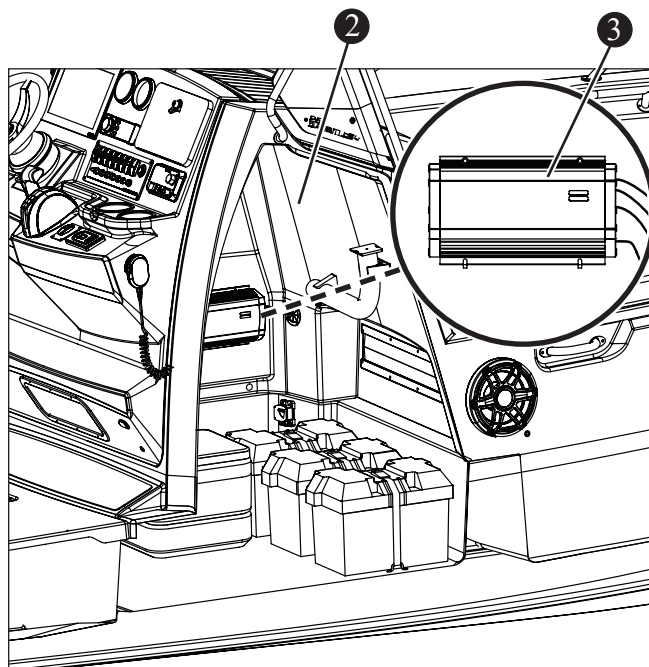

#### ⚠ CAUTION

- Never use an open flame in the battery storage area.
- Avoid striking sparks near the battery.
- A battery will explode if flame or spark ignites hydrogen given off during charging.
- The battery should always be disconnected before doing any work or maintenance on the electrical system.
- Never reset a circuit breaker without first determining and correcting the cause of the trip. Should a circuit repeatedly trip, have a qualified electrician determine and correct the cause.
- If equipped with a battery switch, stop the engine before moving the switch to the off position.

#### ⚠ DANGER

To avoid serious injury or death from fire explosion or electrical shock, the charger must be connected to a ground fault circuit interrupter protected outlet.

#### NOTICE

You can connect a heavy duty UL approved extension cord to the charger. After connecting the extension cord to the charger proceed to plug the extension cord to a nearby 120VAC ground fault circuit interrupter outlet. Always remove the extension cord from the 120VAC outlet first when charging is completed, followed by unplugging the charger.

REFER TO THE OWNER'S PACKET FOR COMPLETE INSTRUCTIONS AND WARRANTY INFORMATION.

### Battery Charge Rate

The battery charger has selectable profiles that affect the charge rate. The charge rate profile is pre-set at the factory to AGM to match the battery type installed on this vessel. Matching the charge rate to the battery type installed extends battery life and maximizes battery performance. Refer to the battery charger manual in the owner's packet for complete instructions and additional information.

### Fuse Block

The fuse block can be accessed through the fuse block access panel on the upper aft wall of the console interior (see Figure 4.5.1). In the event you need to replace a fuse, use only the same amperage as the original (see figure 4.24.1). It is recommended that you carry spare fuses. If a fuse is replaced with one of lower amperage, it will not be sufficient to carry the electrical load of the equipment it is connected to and will cause fuse failure or a circuit breaker tripping. If a fuse is replaced with one of higher amperage, it will not provide adequate protection against an electrical malfunction and will create a fire hazard.

Console Storage Fuse Block Access

Figure 4.5.1

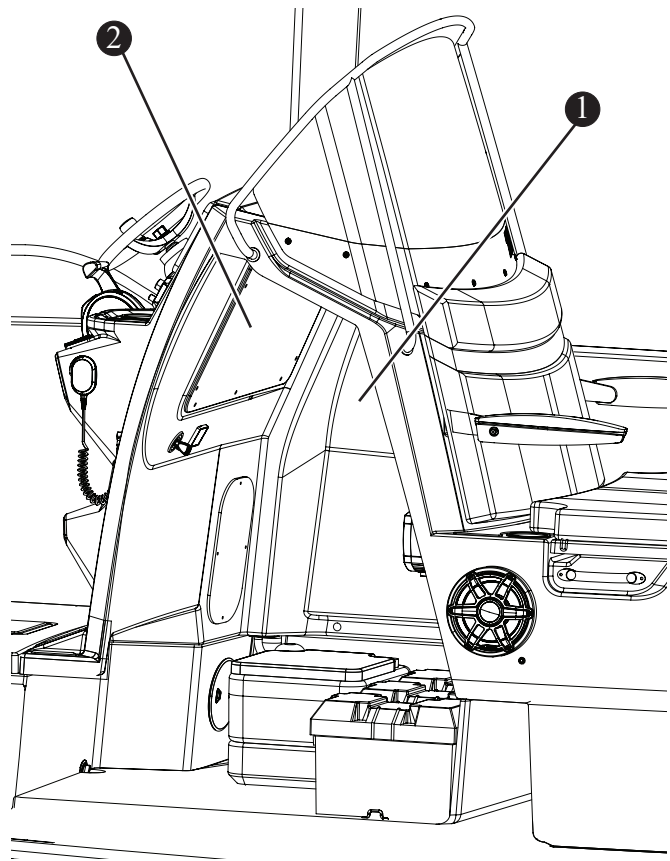
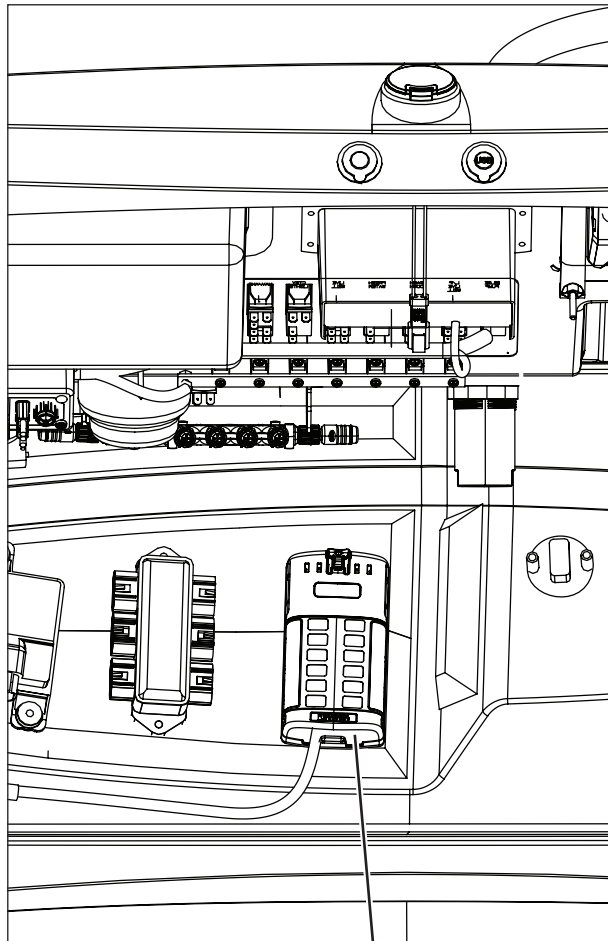

- 1 CONSOLE STORAGE (DOOR NOT SHOWN)
- 2 FUSE BLOCK ACCESS PANEL
- 3 FUSE BLOCK



## Main DC Circuit Breaker

The main DC circuit breaker off-on/reset switch is located in the port aft deck access hatch Figure 4.6.1. If the main DC circuit breaker trips determine and correct the problem prior to resetting the circuit breaker. To reset the circuit breaker, rotate the switch to the *ON* position.

Main DC Circuit Breaker  
Figure 4.6.1

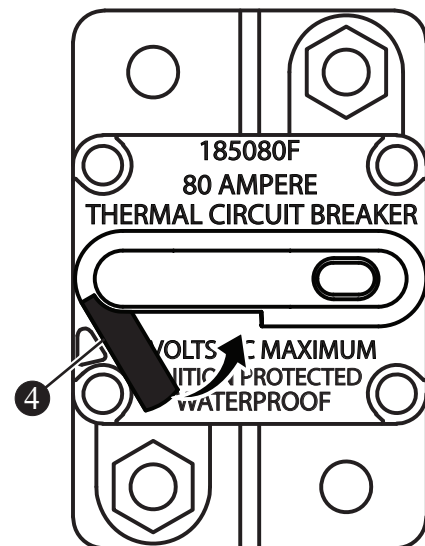
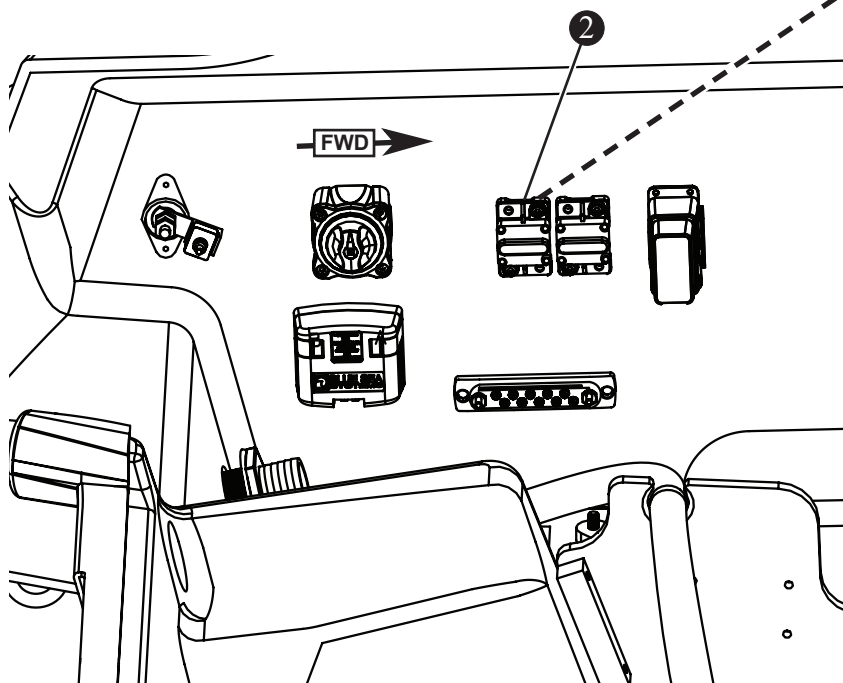
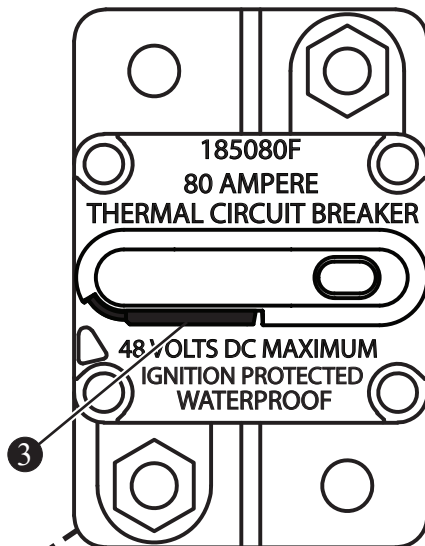
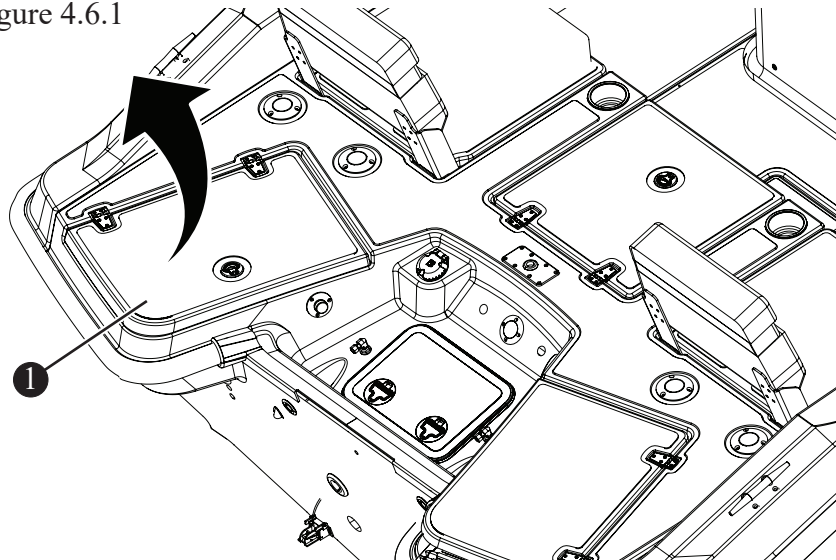

- 1 PORT DECK ACCESS HATCH
- 2 MAIN DC CIRCUIT BREAKER (80 AMP)
- 3 BREAKER SWITCH (ON POSITION)
- 4 BREAKER SWITCH (OFF POSITION)

### **WARNING**

Use of higher amperage fuses or breakers is a fire hazard. Use fuses and breakers having the same amperage rating as the original or as specified.

### Transducer (Option)

If equipped, the transducer is located on the transom and acts as an antenna for the sonar system, sending sound waves through the water, bouncing off objects, and returning a signal. Should after market installation be required, contact a Boston Whaler dealer for details on the mounting location shown in Figure 4.7.1.

Transducer (Option)

Figure 4.7.1

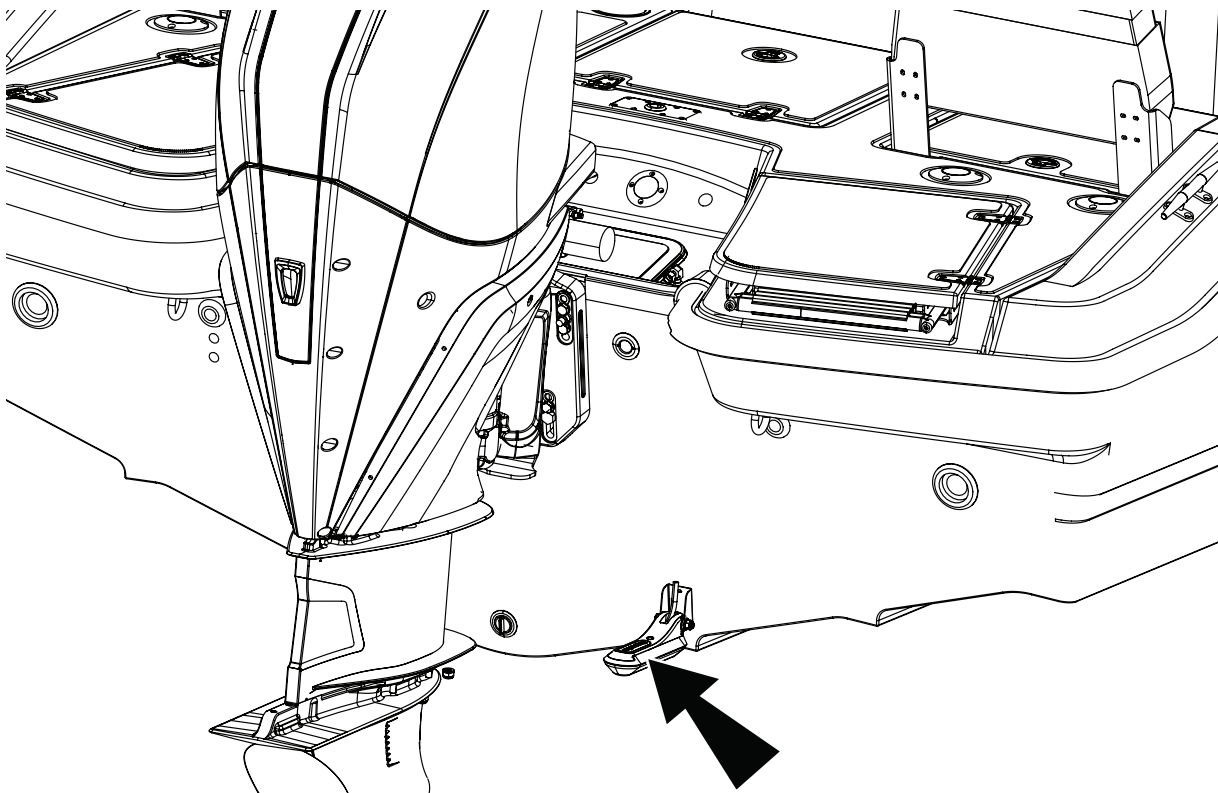

## Rigging Pull

A factory-installed rigging pull is provided to assist with the running of new wiring. This vessel is equipped with a rigging pull tied off at either end of the rigging trough (see Figure 4.8.1). When using a rigging pull be sure to attach a cord to each run of the new wiring to ensure a new pull is in place for future use.

For further information on rigging pulls, contact your dealer or Boston Whaler.

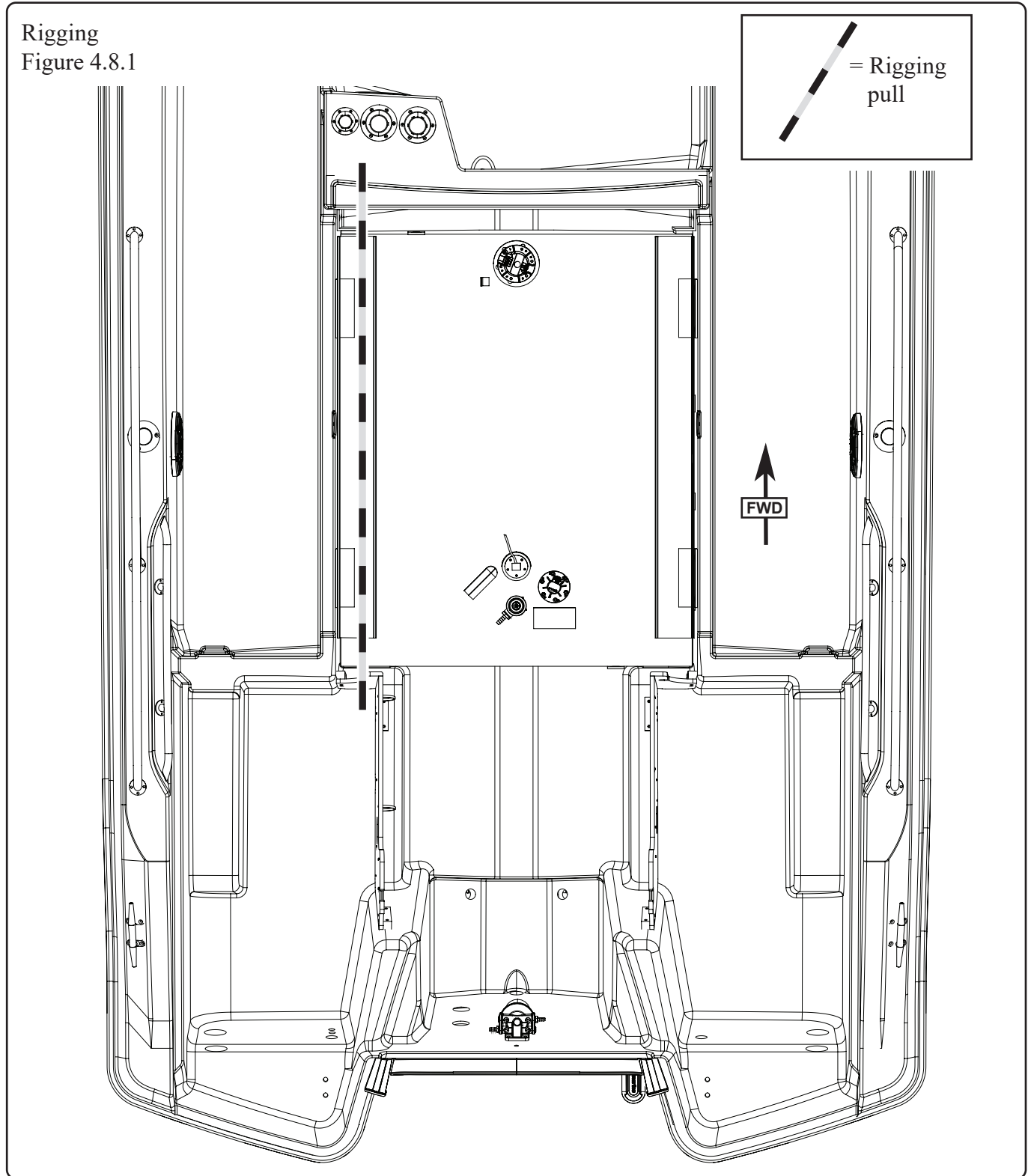

## Chapter 4 • Electrical

### Wiring

Boston Whaler adheres to electrical wiring requirements that meet ABYC E-11 standards. The following table details the color and function of wiring used.

**Wire Color Chart for DC and Special Circuit**

COLOR	FUNCTION	COLOR	FUNCTION
RED	MAIN FEEDS.	BRN/GRY	RAW WATER
RED	+12V MAIN.	BRN/RED	LIVEWELL PUMP
RED	12V RECEPTACLE.	BRN/WHT	BILGE PUMP (SWITCHED)
RED	ELECTRIC TRIM TAB (SWITCHED)	GRY	RUNNING LIGHTS
BLK	GROUND	GRY/WHT	ALL ROUND MAST LIGHT
BLU	COMPASS LIGHT	GRN	GROUNDING/BONDING
BLU/RED	DOME LIGHT	ORN	HORN
BLU/RED	LIVEWELL LIGHT	PINK	FUEL SENDER
BLU/RED	COURTESY LIGHTS (BLUE)	VIO	IGNITION
BLU/WHT	COURTESY LIGHTS (WHITE)	WHT/RED	PORT ELECTRIC TRIM TAB
BRN	BILGE PUMP (UNSWITCHED)	WHT/GRN	STBD ELECTRIC TRIM TAB
BRN/GRN	FRESH WATER	YLW	STEREO MEMORY
		YLW/RED	START

### Electrical Schematics

The harnesses and schematics on the following pages are for reference and to be used by Boston Whaler service technicians. Boston Whaler reserves the right to change or update the electrical system on any model at any time without notice. In addition, Boston Whaler is not obligated to make any updates to units built prior to a change. Contact customer service for current electrical schematics.

DC Main Harness (Page 1 of 3)

Figure 4.10.1

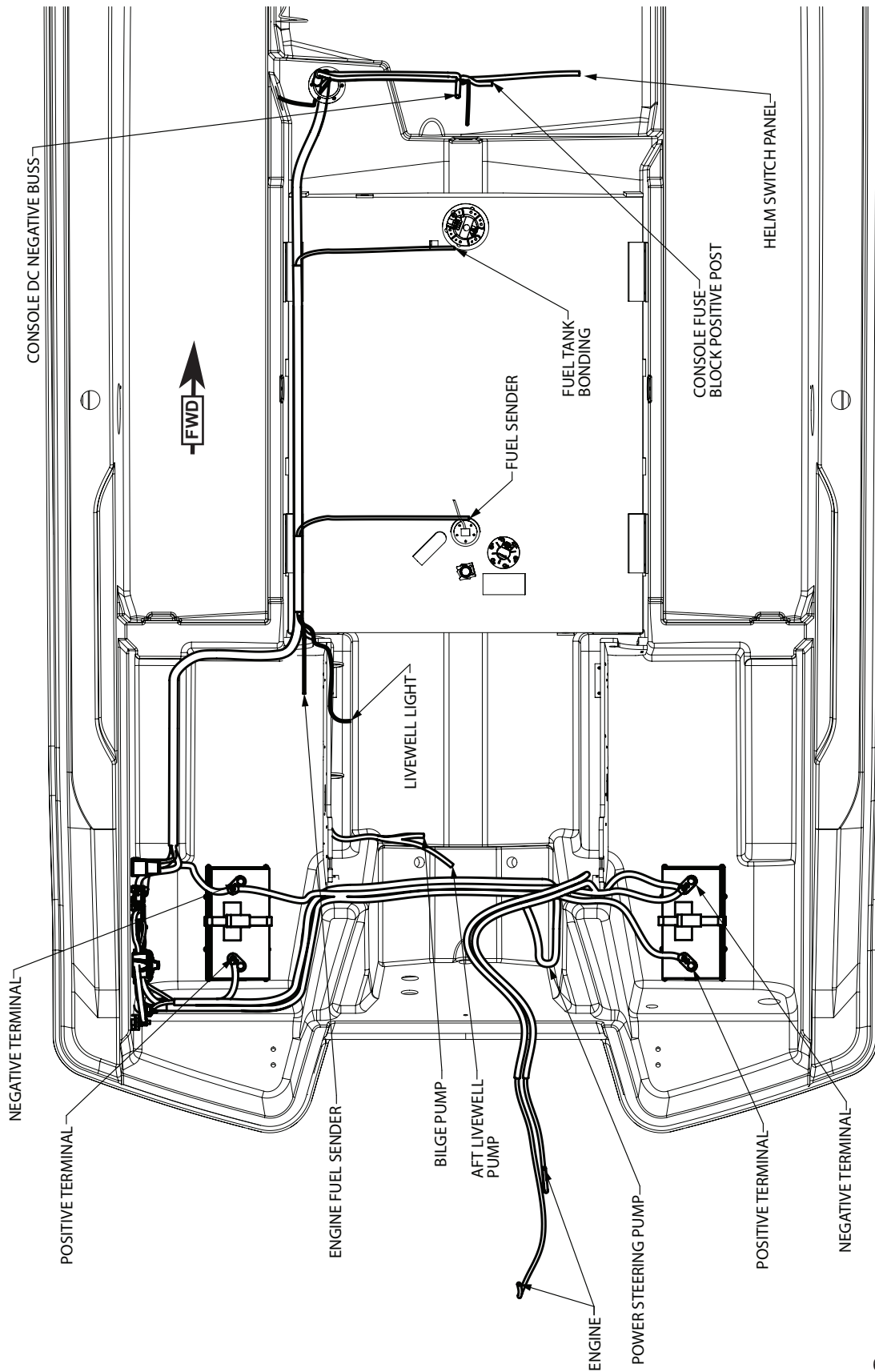

6040-07-801\_2\_F

DC Main Harness (Page 2 of 3)

Figure 4.11.1

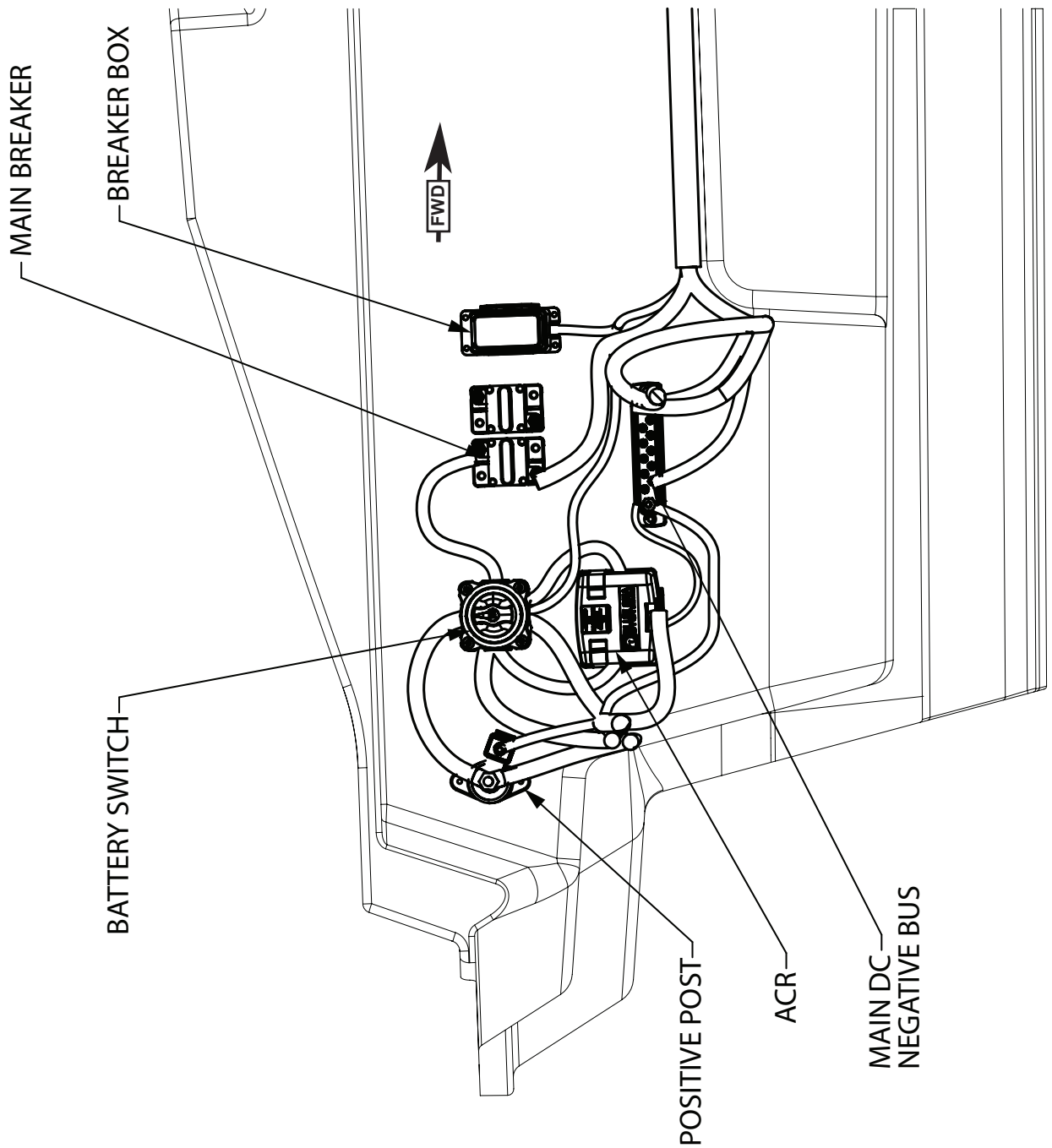

6040-07-801\_2\_F

DC Main Harness (Page 3 of 3)

Figure 4.12.1

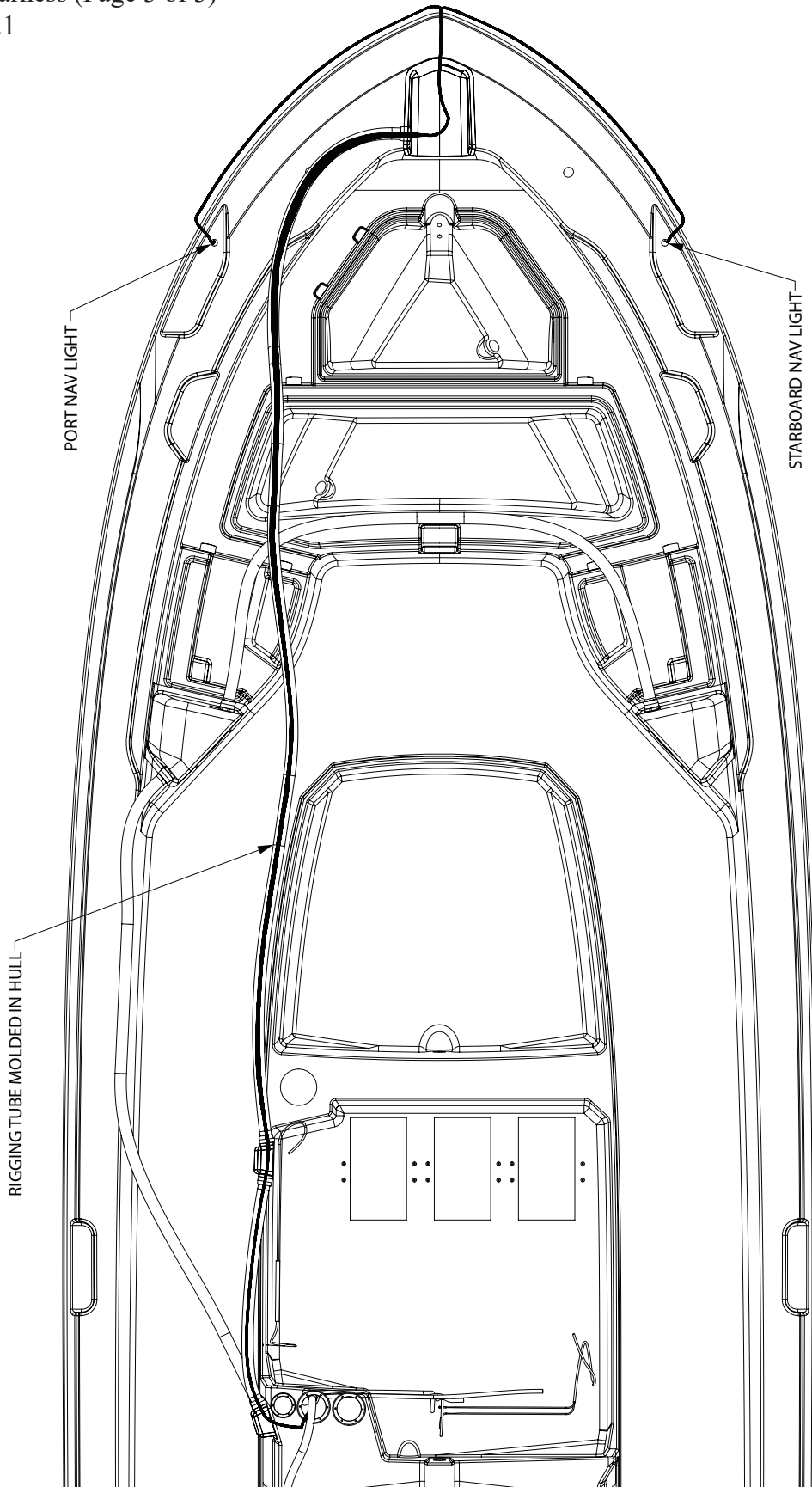

6040-07-801\_3\_F

## Console Harness (Page 1 of 2)

Figure 4.13.1

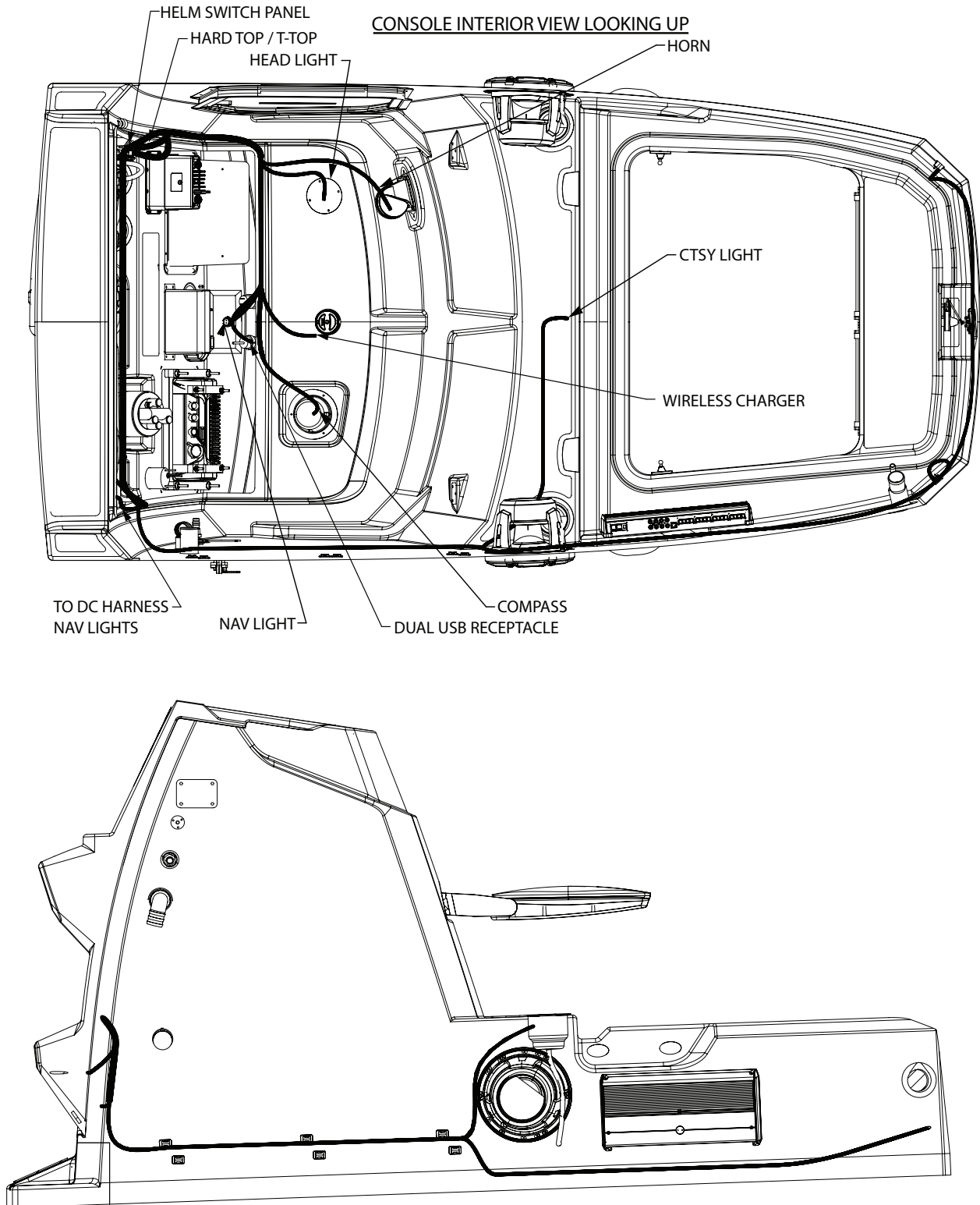

6040-07-801\_4\_F



Console Harness (page 2 of 2)  
Figure 4.14.1

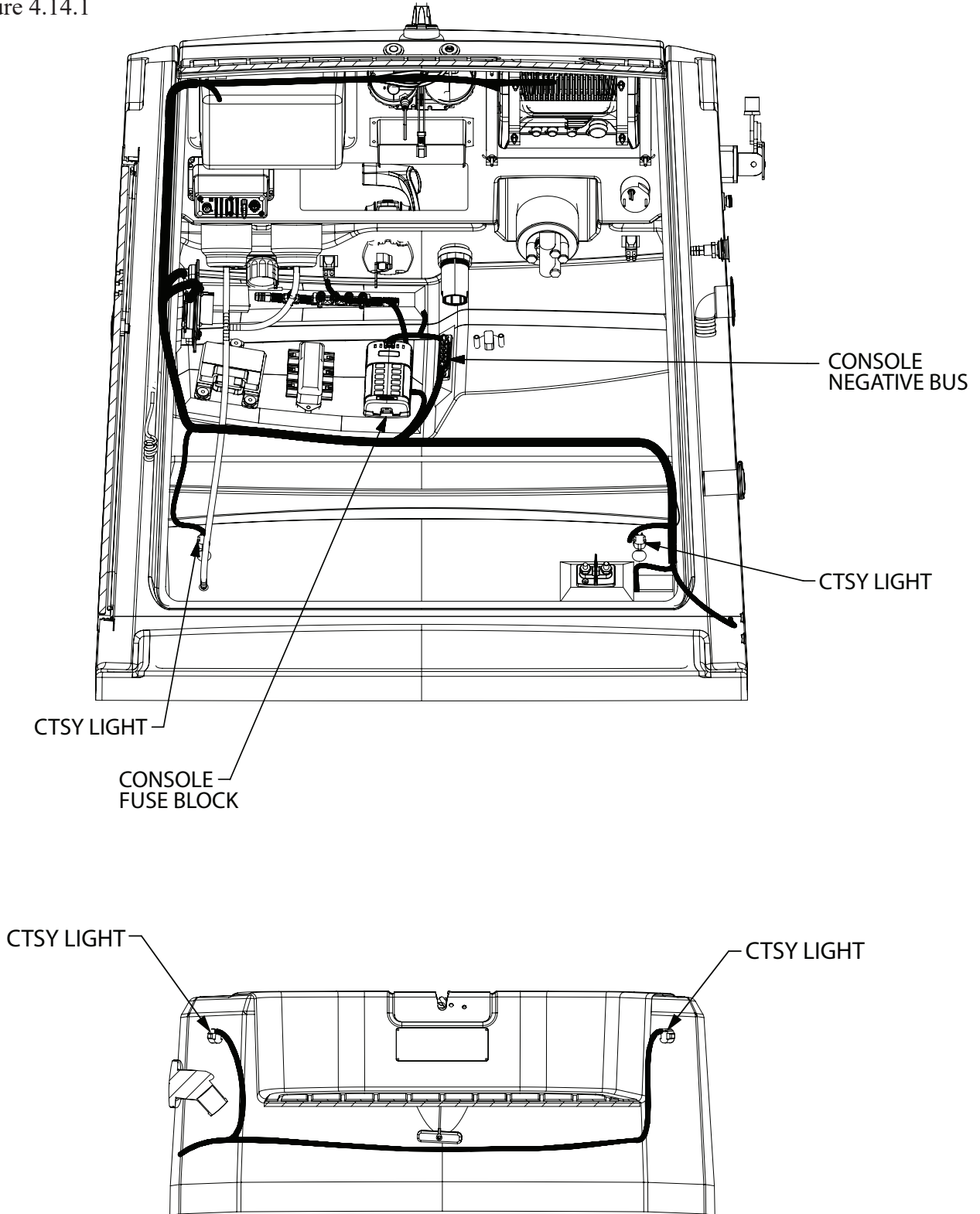

6040-07-801\_4\_F

Freshwater Harness (Option)  
Figure 4.15.1

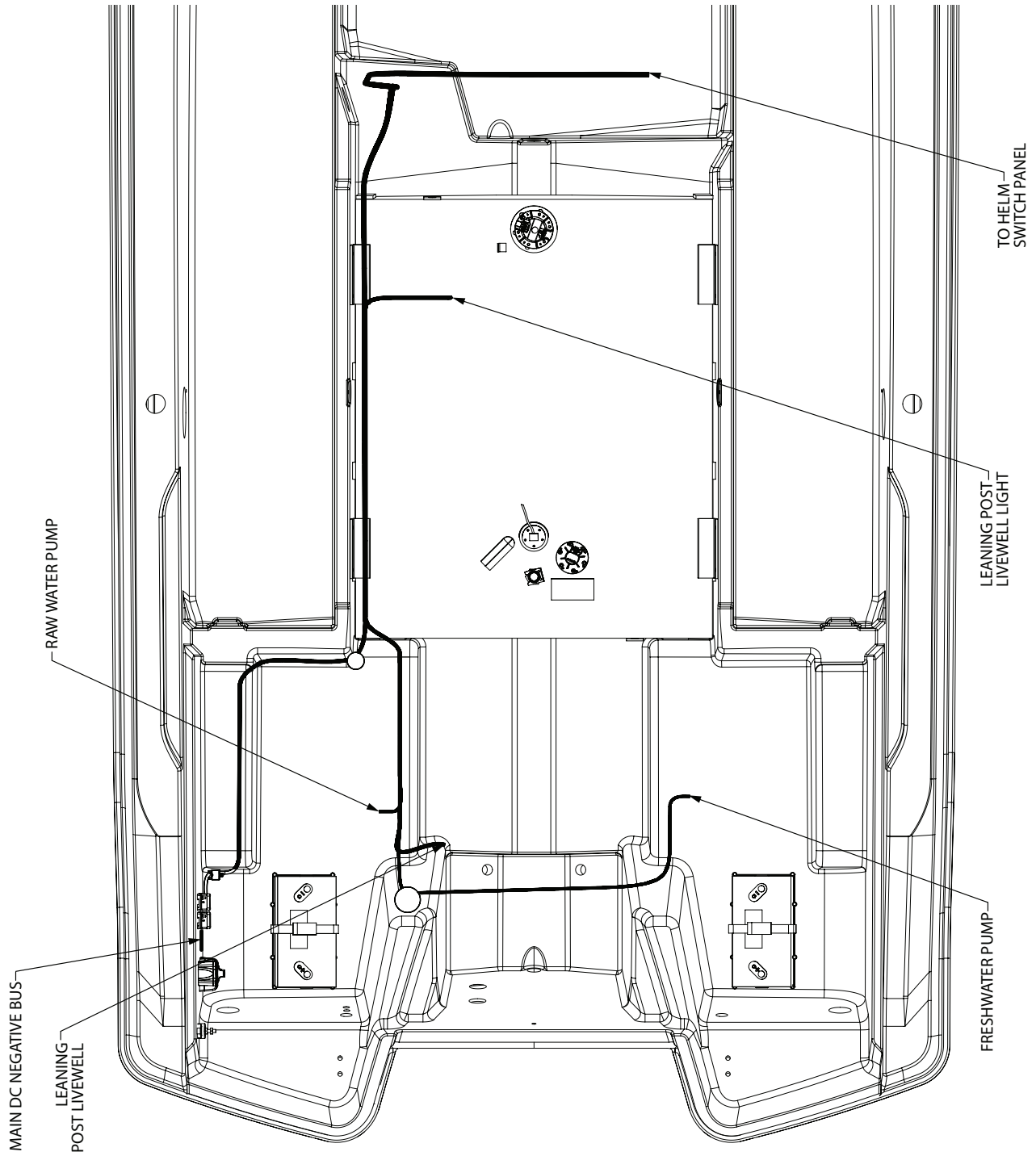

6040-07-801\_5\_F

Stereo Speakers Harness (Option) (page 1 of 2)  
Figure 4.16.1

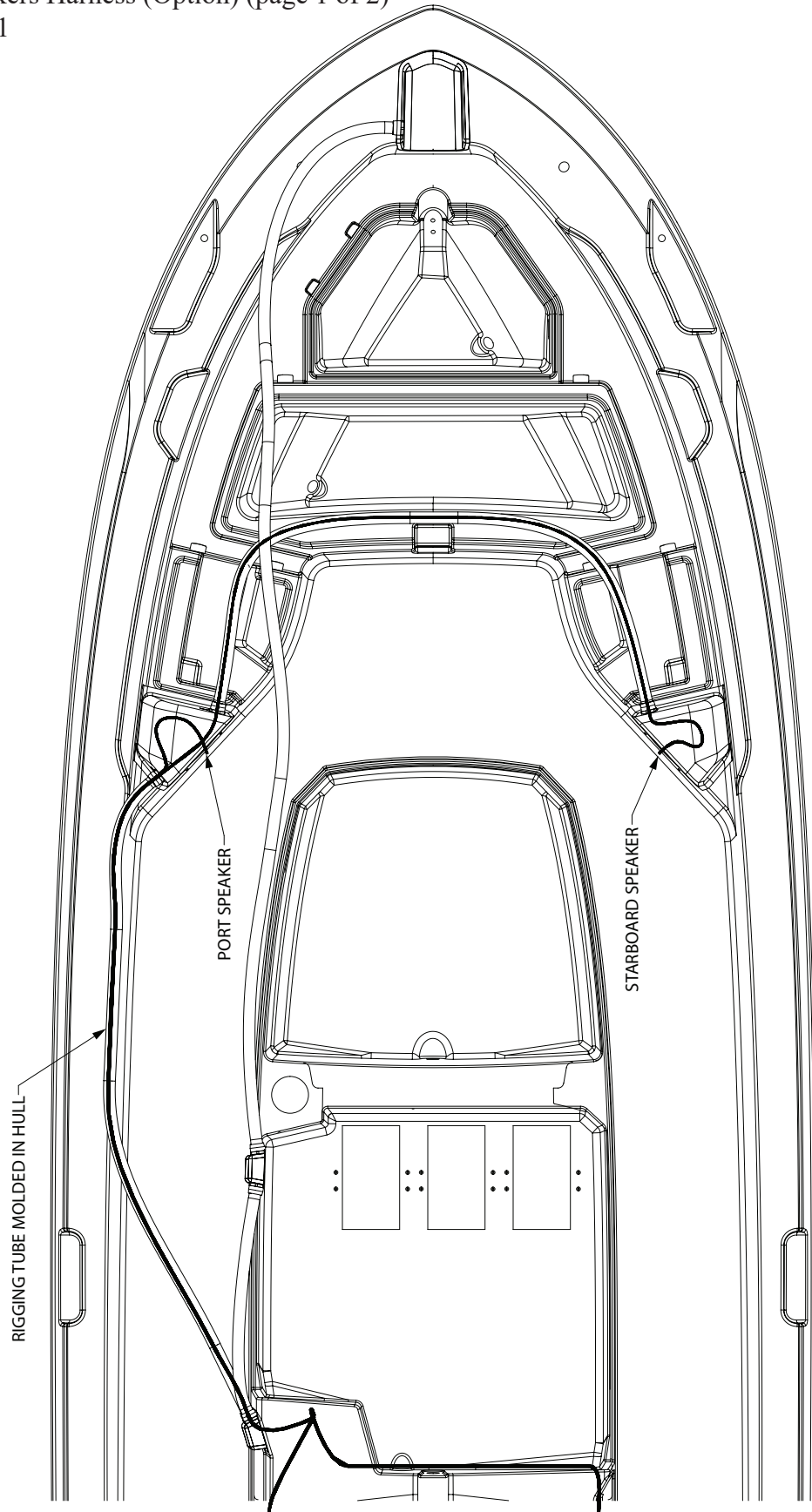

6040-07-801\_6\_F

Stereo Speakers Harness (Option) (page 2 of 2)  
Figure 4.17.1

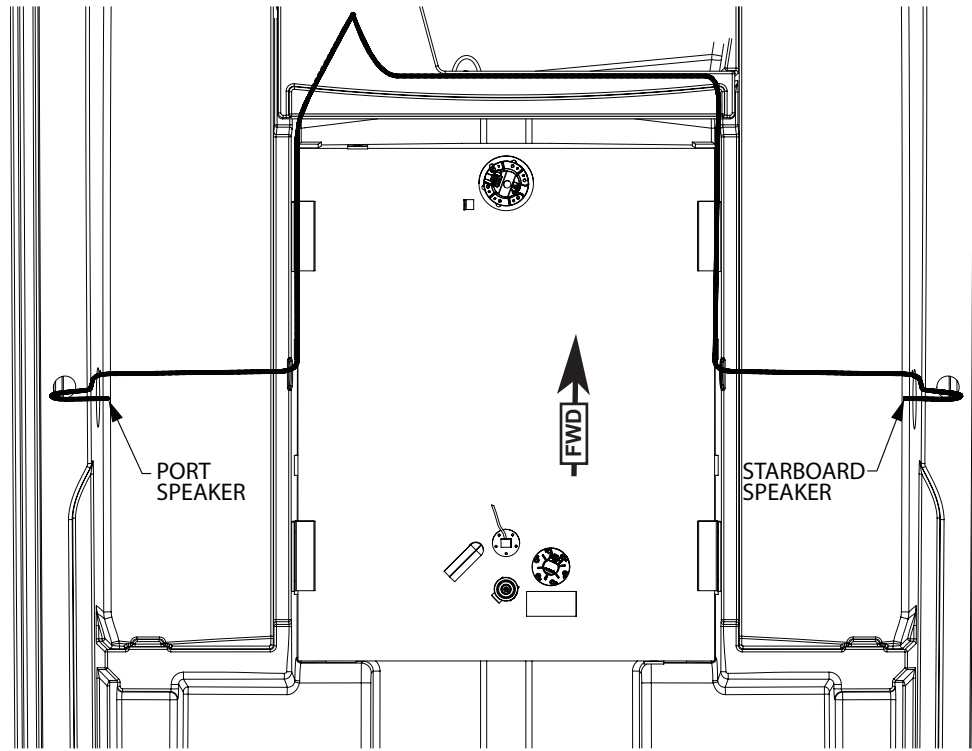

6040-07-801\_7\_F

Stereo Harness (Option)  
Figure 4.17.1

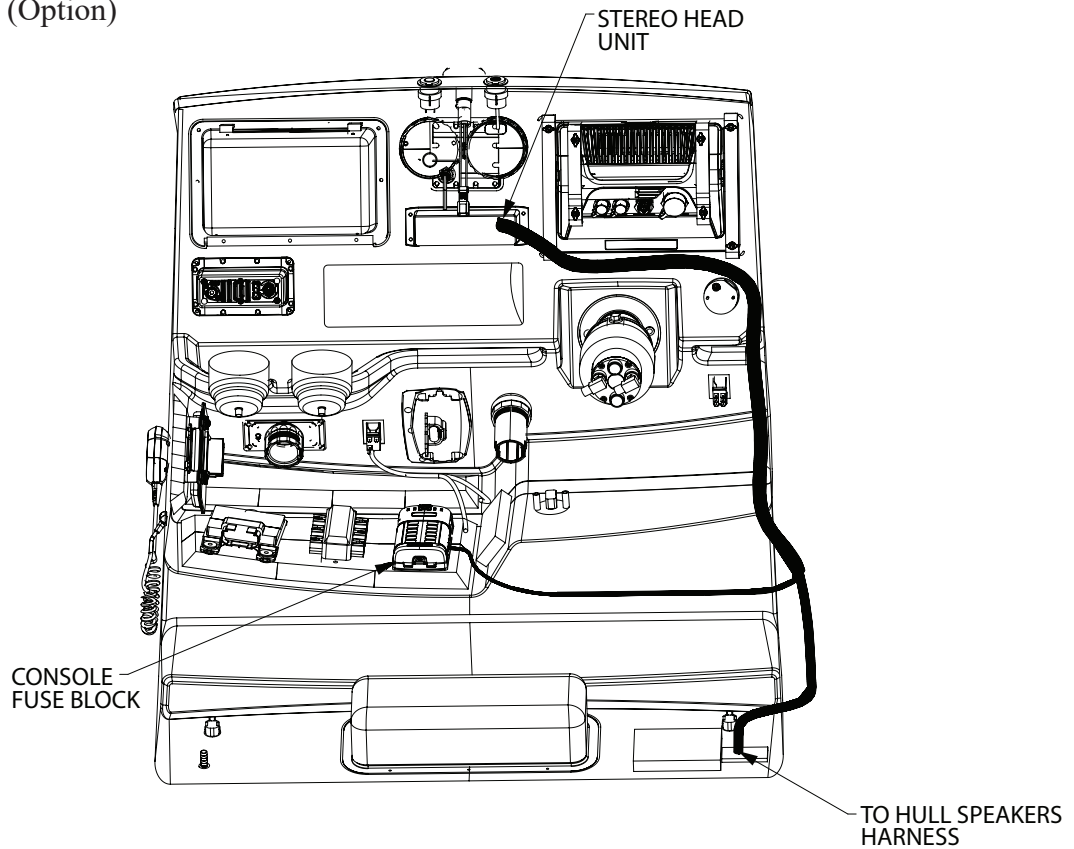

6040-07-801\_7\_F

Stereo Amplifier Power Harness (Option)

Figure 4.18.1

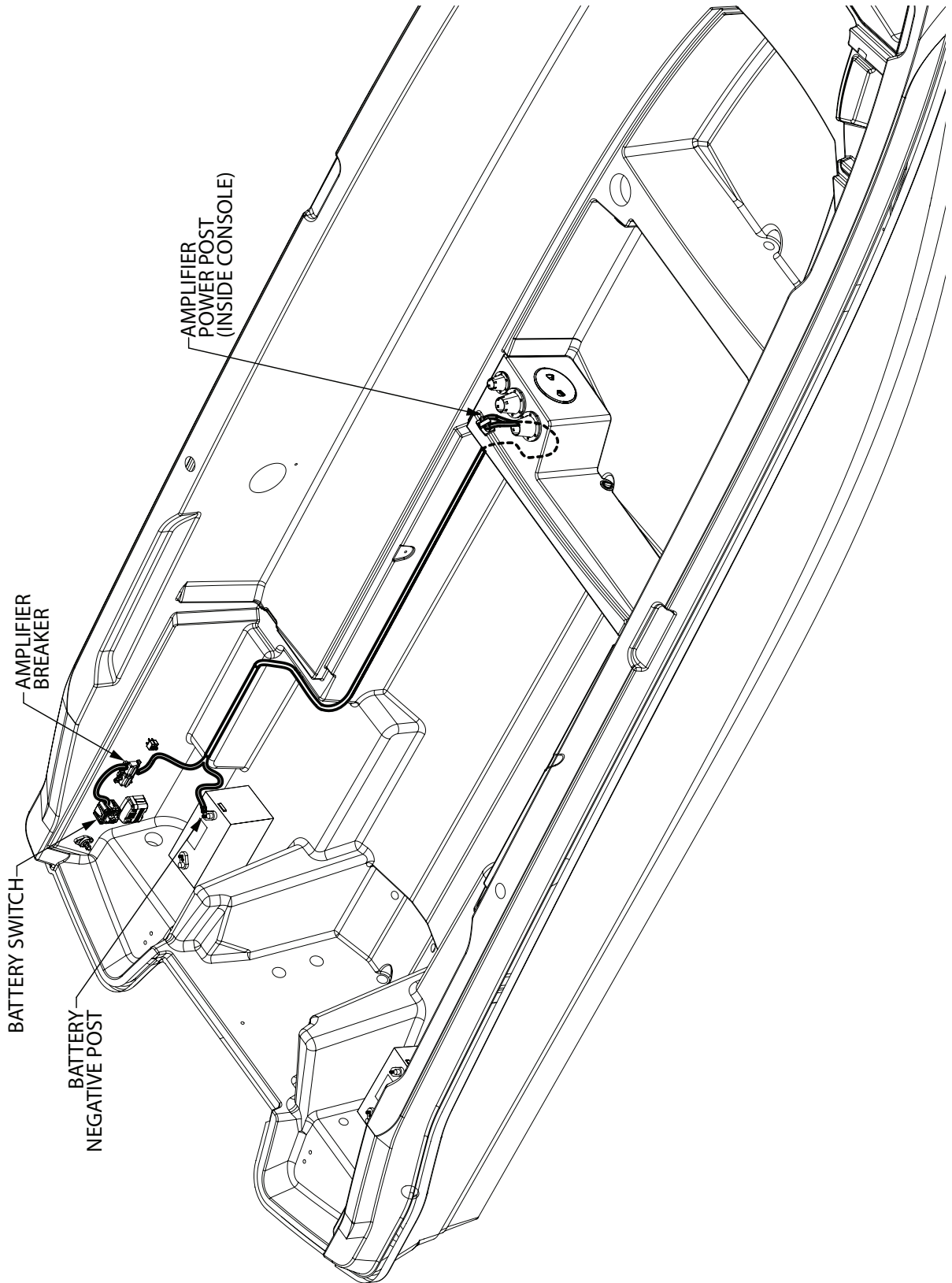

6040-07-801\_8\_F

Stereo with Amplifier Harness (Option)  
Figure 4.19.1

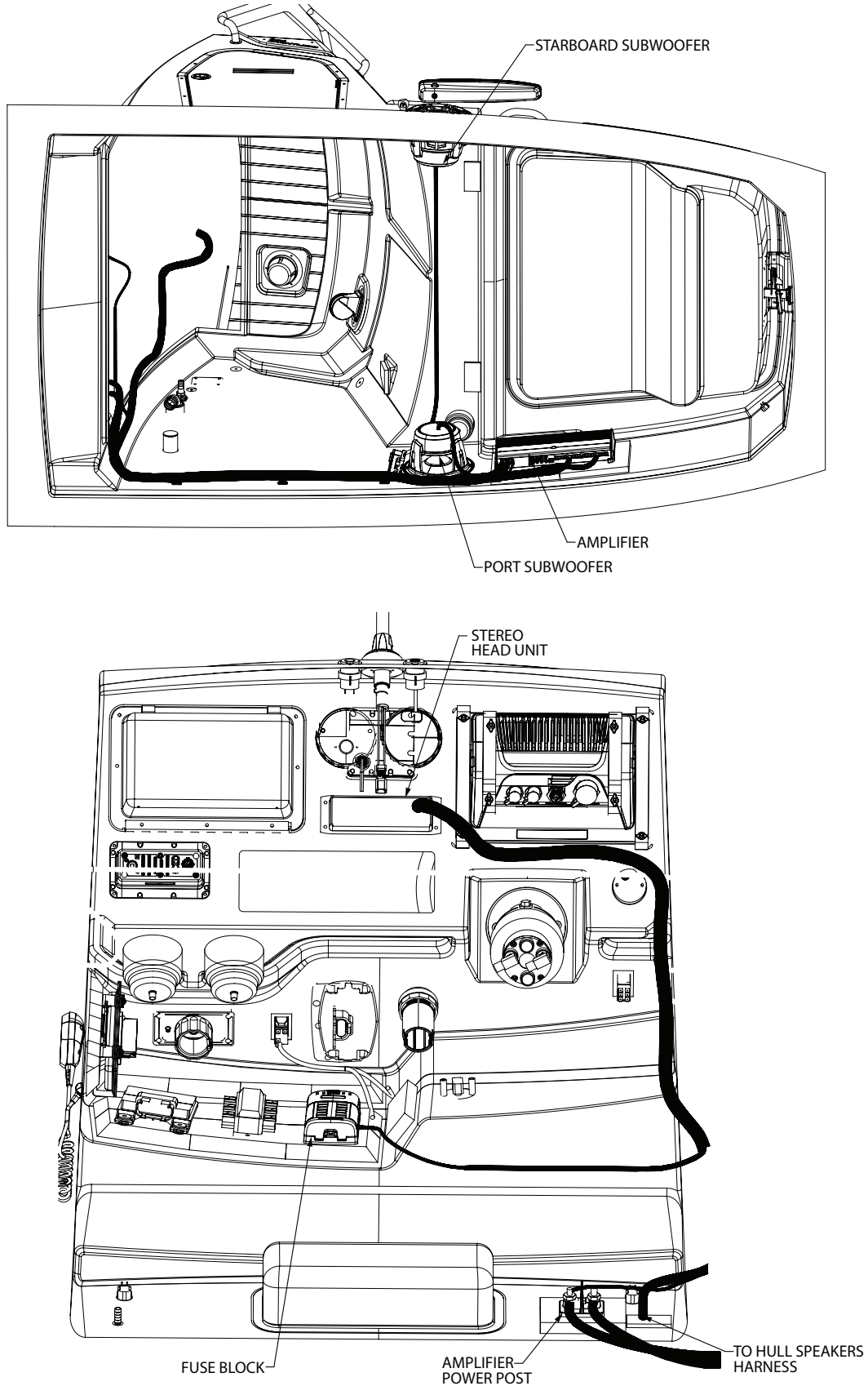

6040-07-801\_9\_F

Trolling Motor Harness (Option)  
Figure 4.20.1

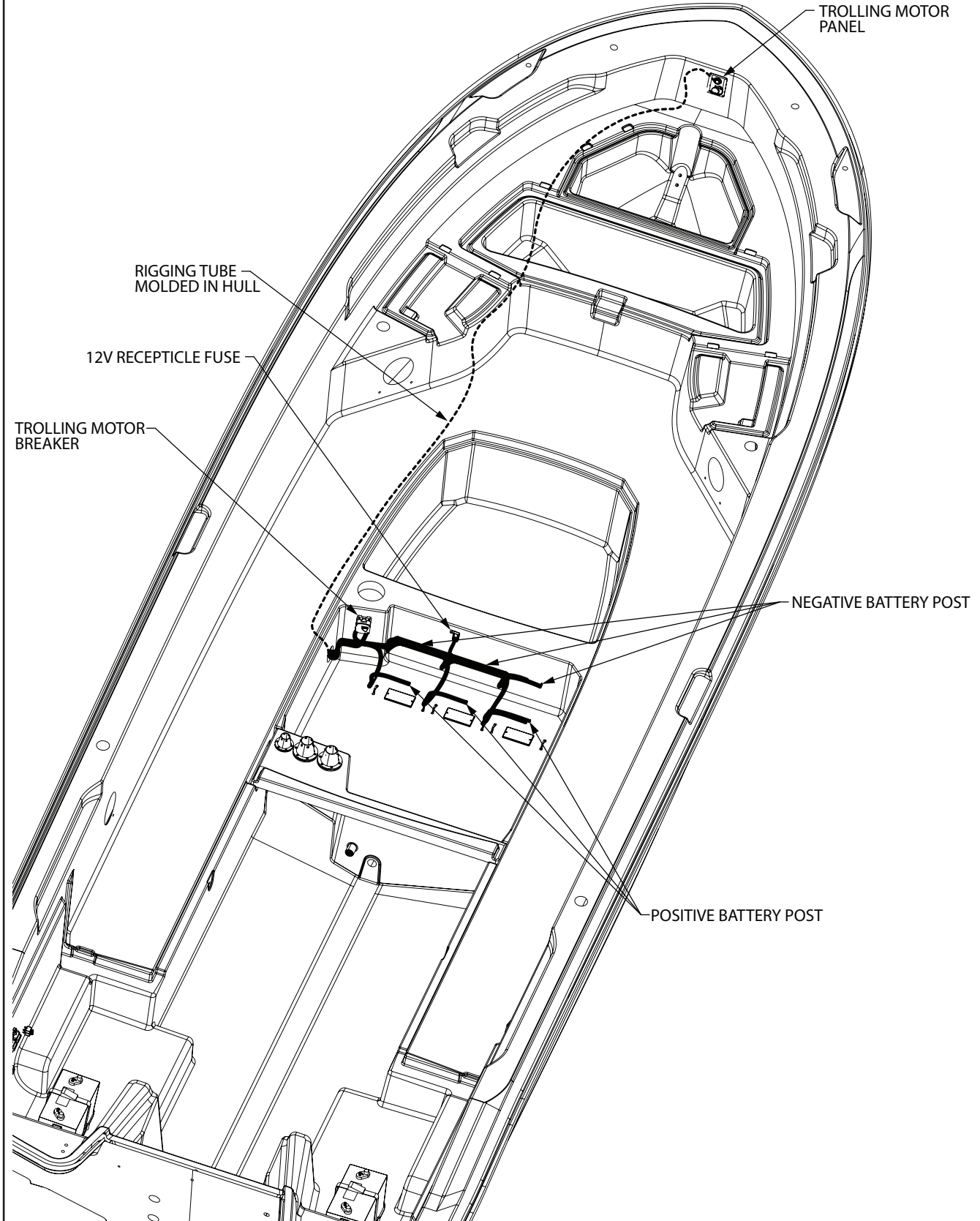

6040-07-801\_10\_F

Hardtop Harness (Option)  
Figure 4.21.1

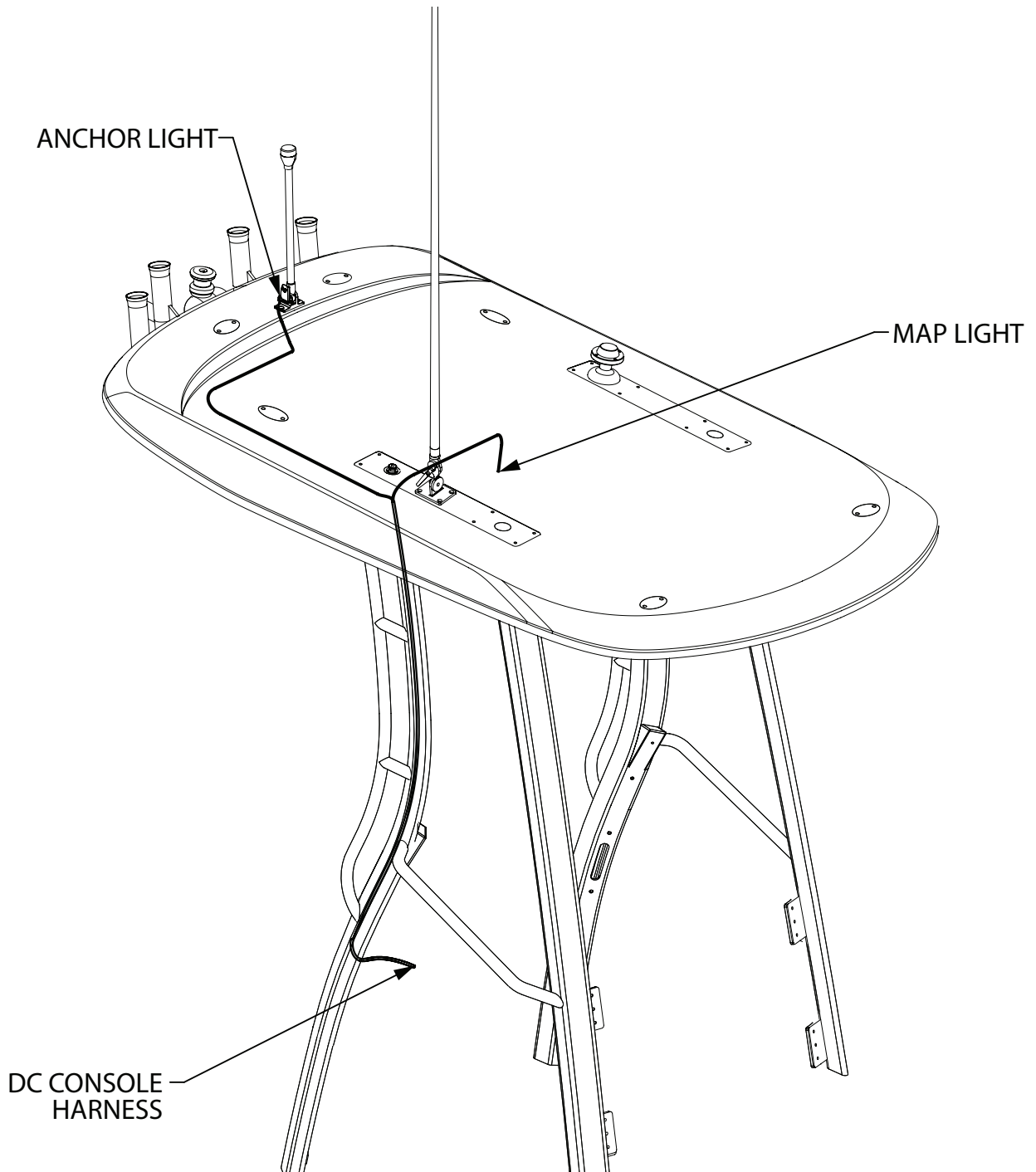

6040-07-801\_11\_F



T-Top Harness (Option)  
Figure 4.22.1

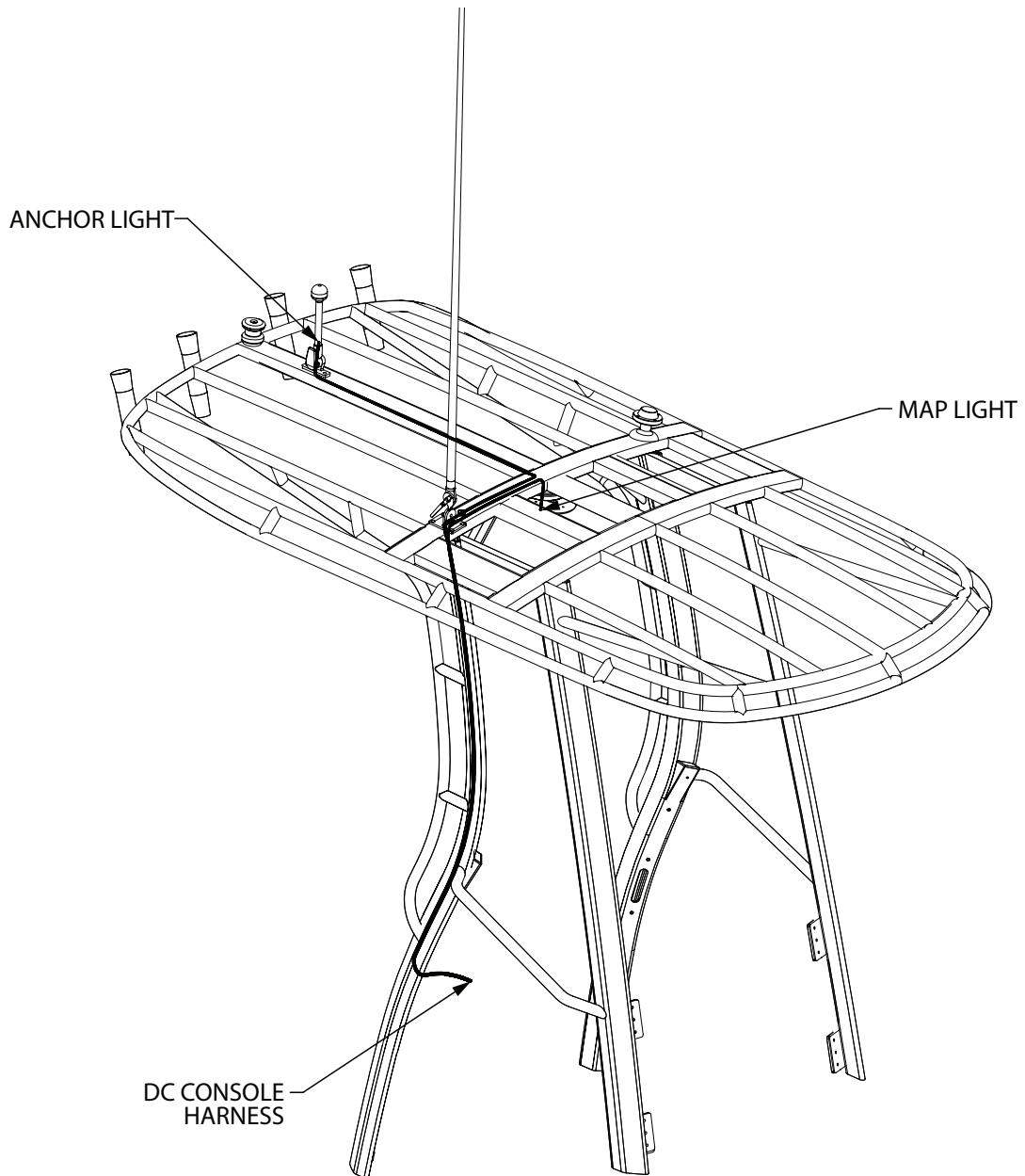

6040-07-801\_11\_F

DC Main and Battery  
Figure 4.23.1

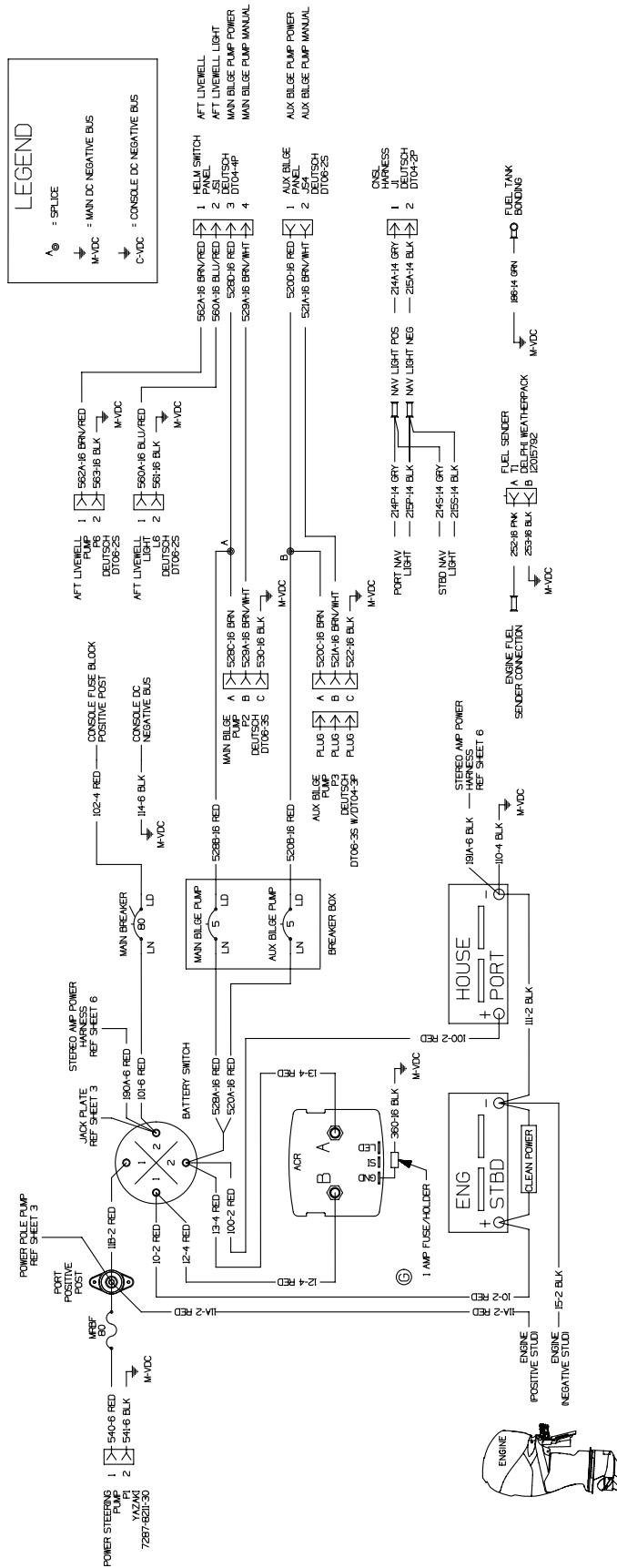

6040-07-401\_2\_H

DC Console Fuse Block  
Figure 4.24.1

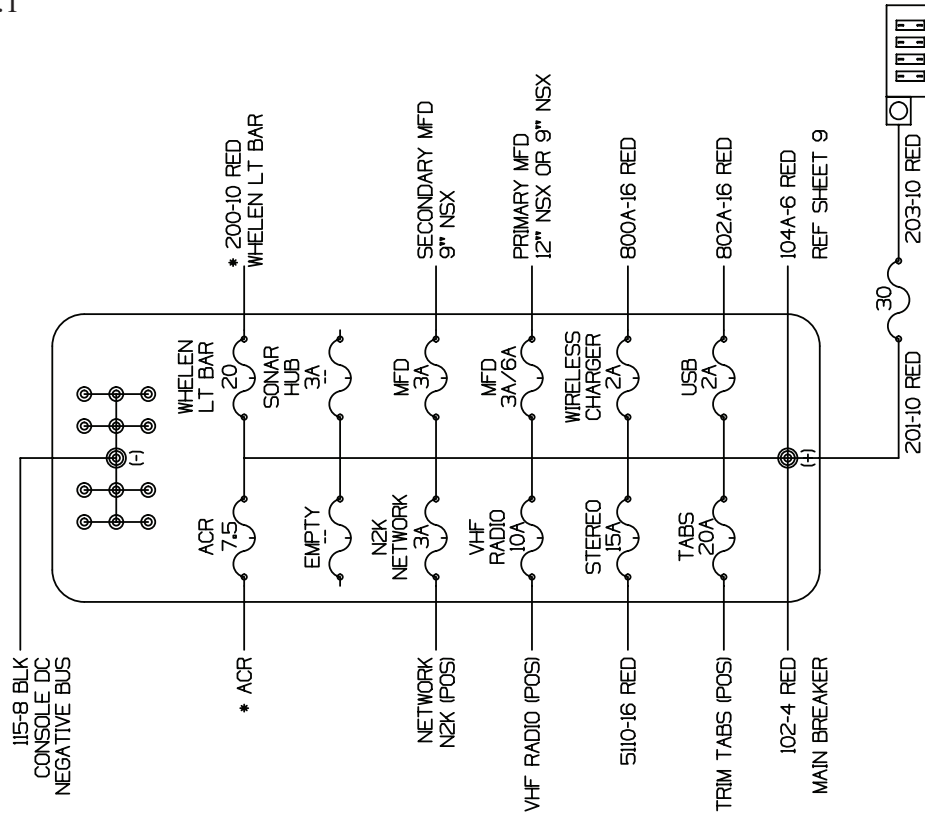

6040-07-401\_2\_H

DC Negative Bus  
Figure 4.24.2

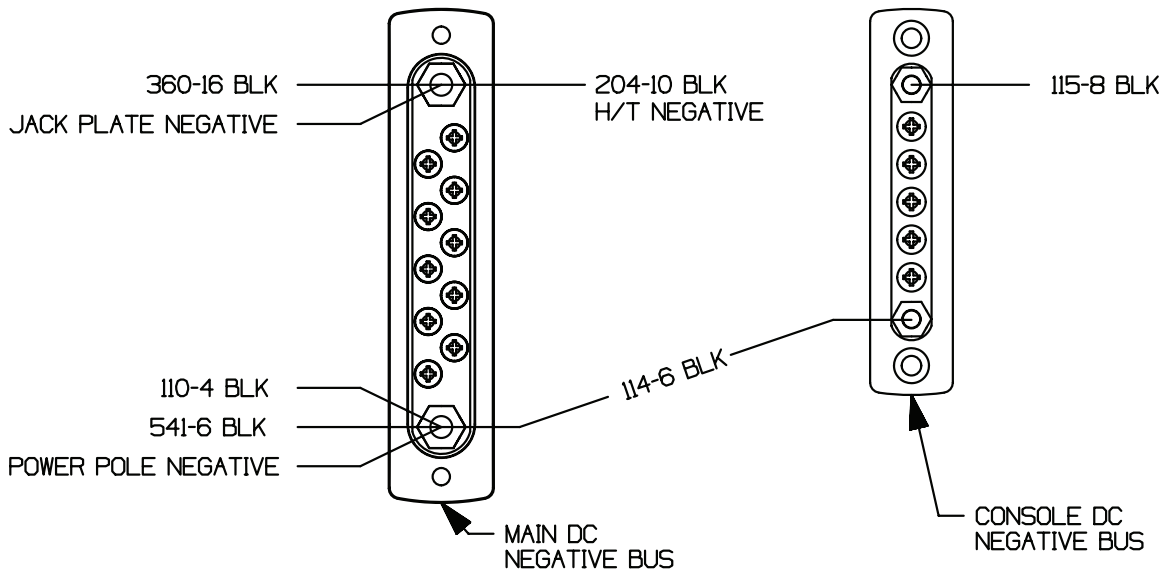

6040-07-401\_2\_H

DC Component Connections  
Figure 4.25.1

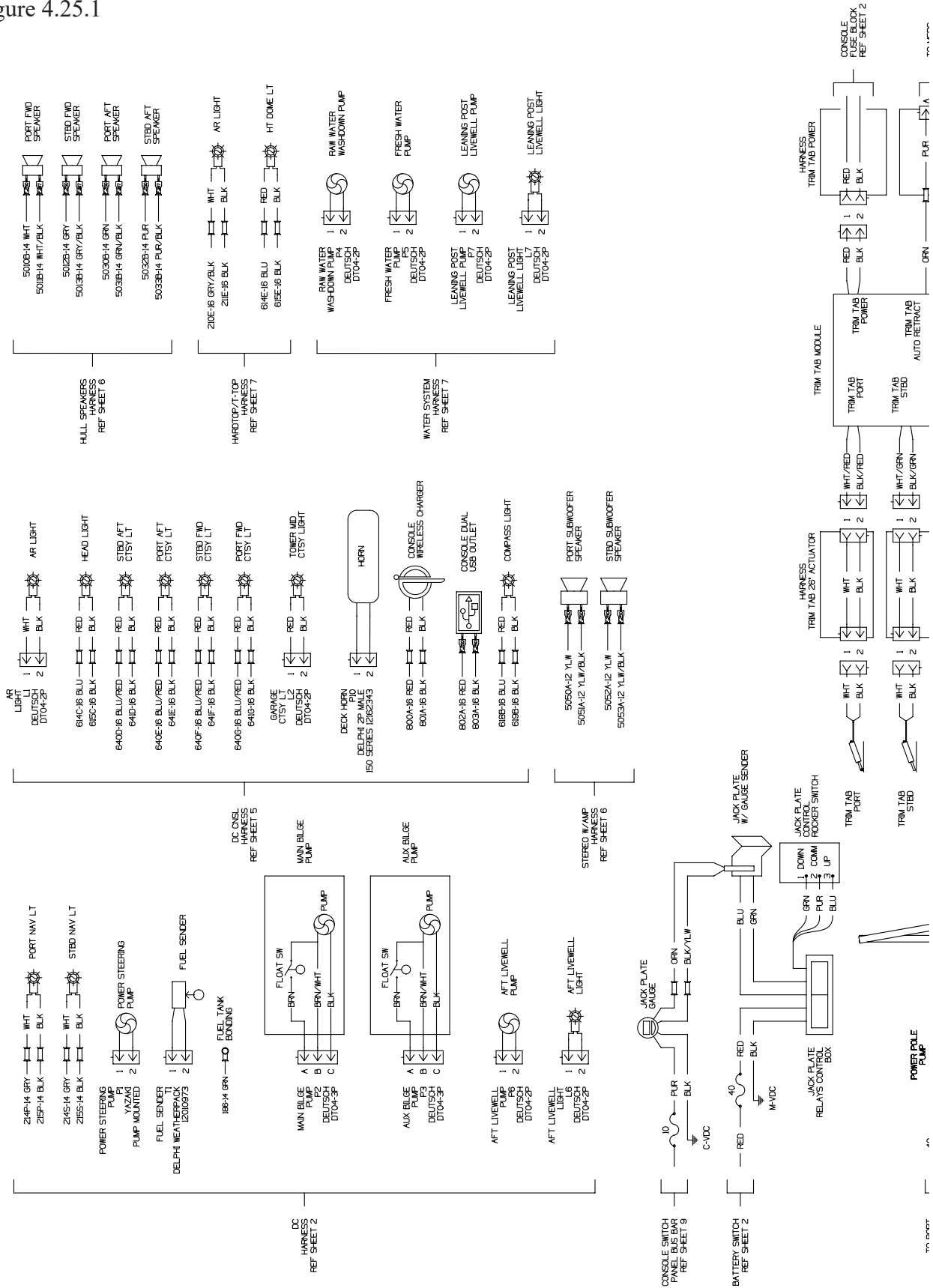

6040-07-401\_3\_H

Stereo System and Premium Audio (Option)  
Figure 4.26.1

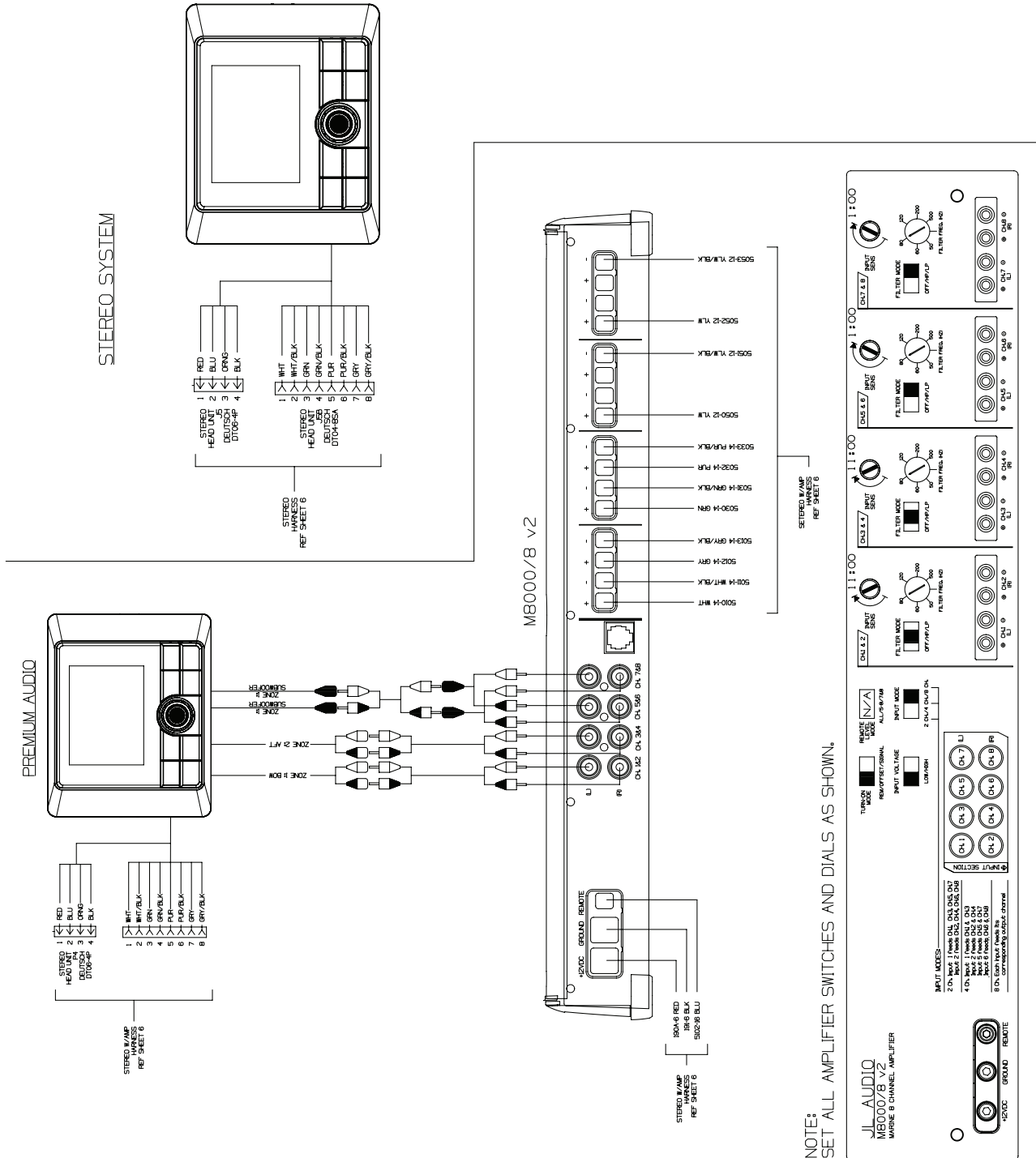

## Console Harness Figure 4.27.1

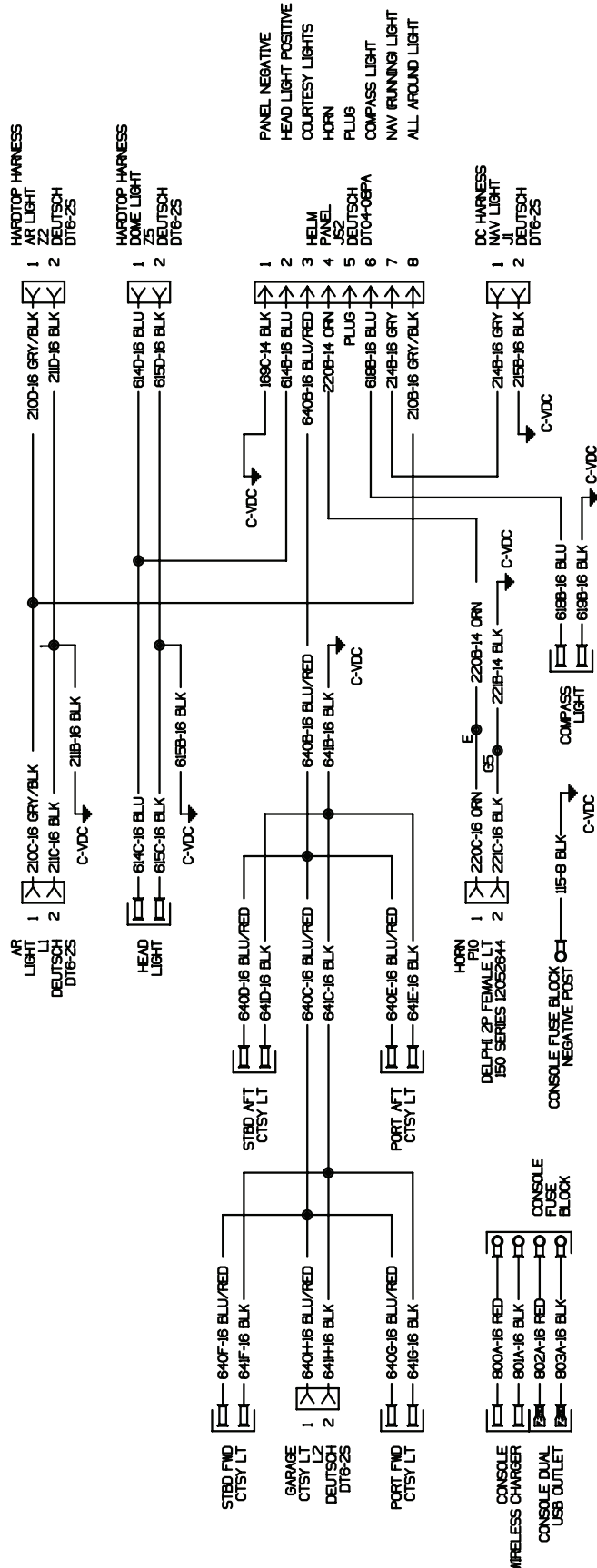

## Stereo Wiring without Amplifier Harness (Option)

Figure 4.28.1

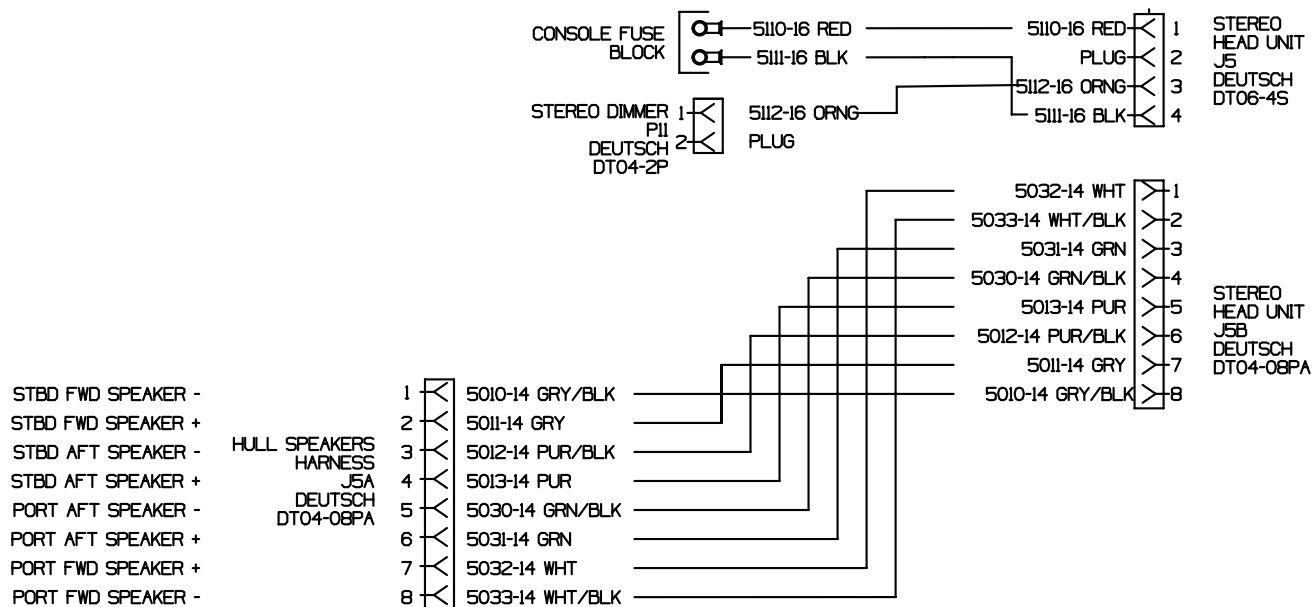

6040-07-401\_6\_H

## Stereo Speakers Harness (Option)

Figure 4.28.2

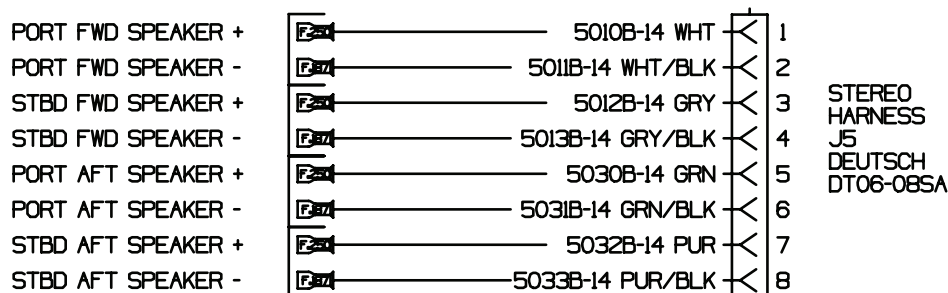

6040-07-401\_6\_H

## Stereo Wiring with Amplifier Harness (Option)

Figure 4.29.1

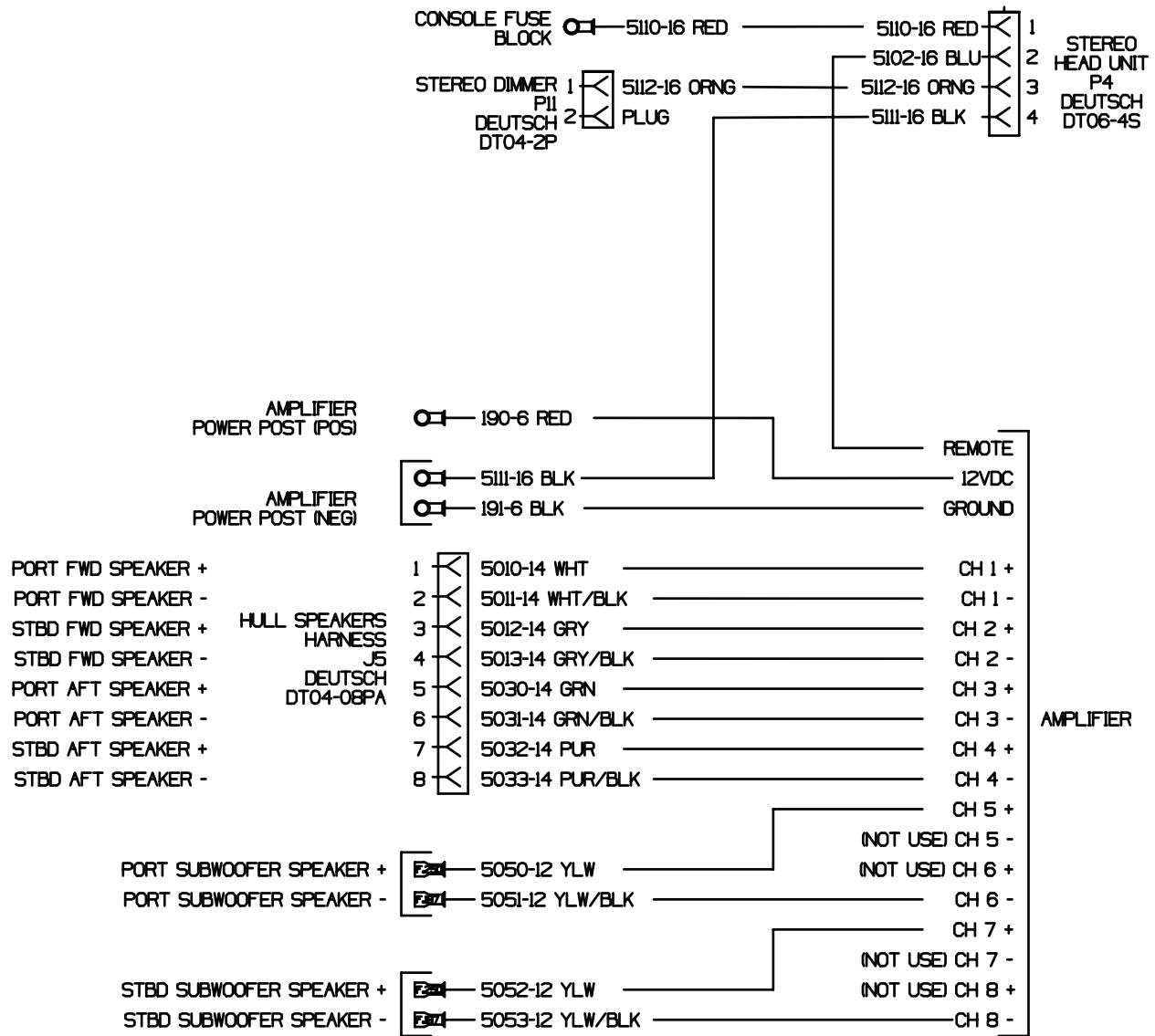

6040-07-401\_6\_H

## Stereo Amplifier Power Harness (Option)

Figure 4.29.2

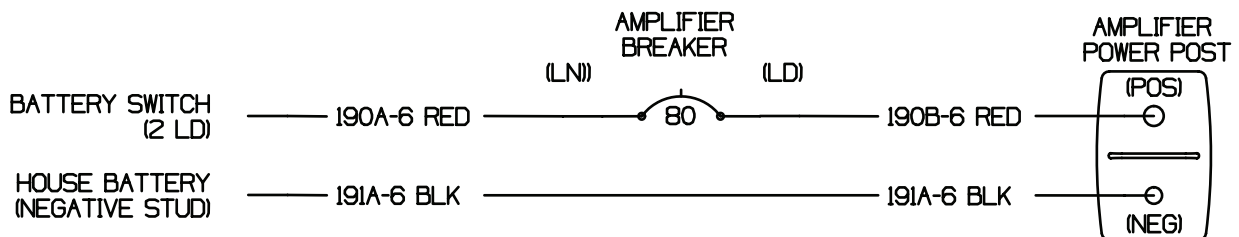

6040-07-401\_6\_H



**CE Auxiliary Bilge Pump (Option)**  
**Figure 4.30.1**

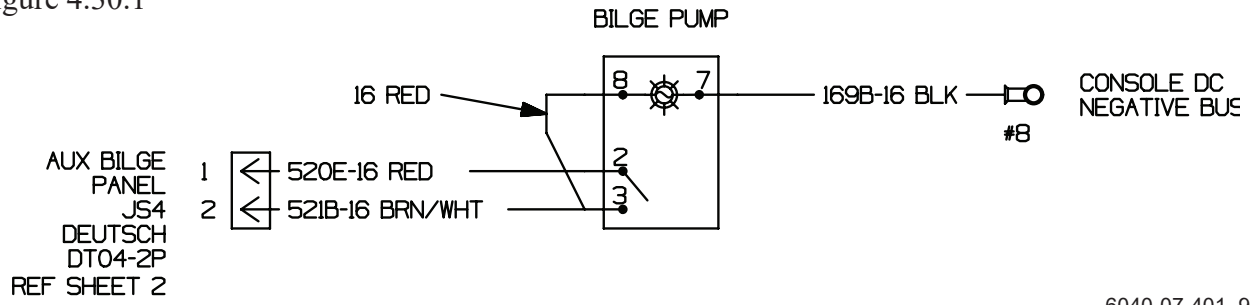

6040-07-401\_9\_H

**Water System (Option)**  
**Figure 4.30.2**

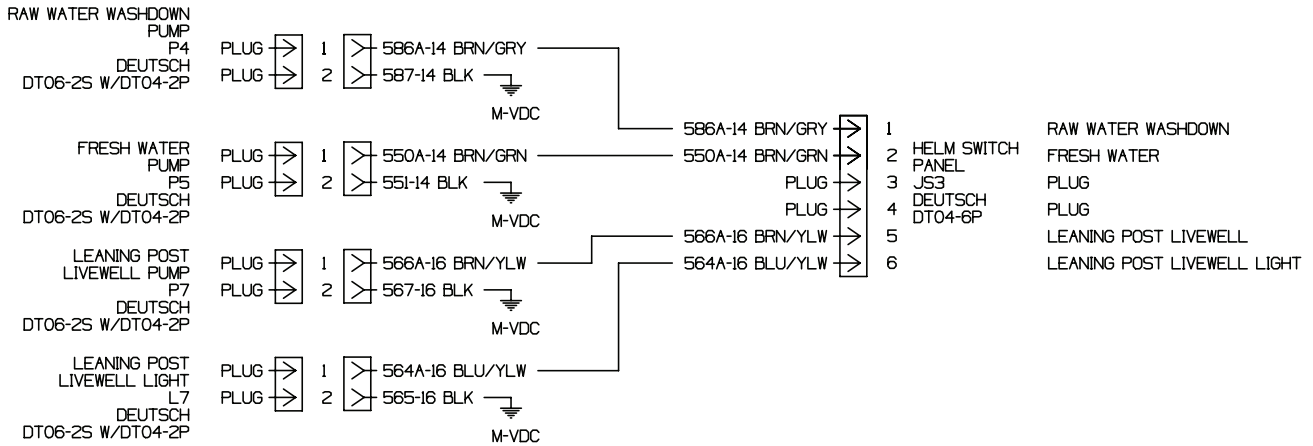

6040-07-401\_7\_H

**Hardtop and T-top Harness (Option)**  
**Figure 4.30.3**

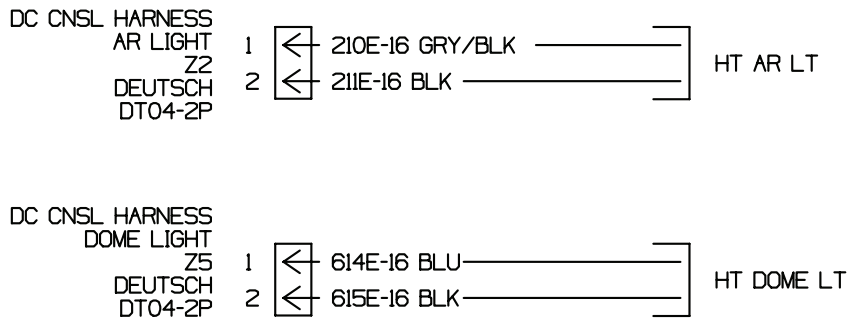

6040-07-401\_7\_H

Trolling Motor Harness (Option)  
Figure 4.31.1

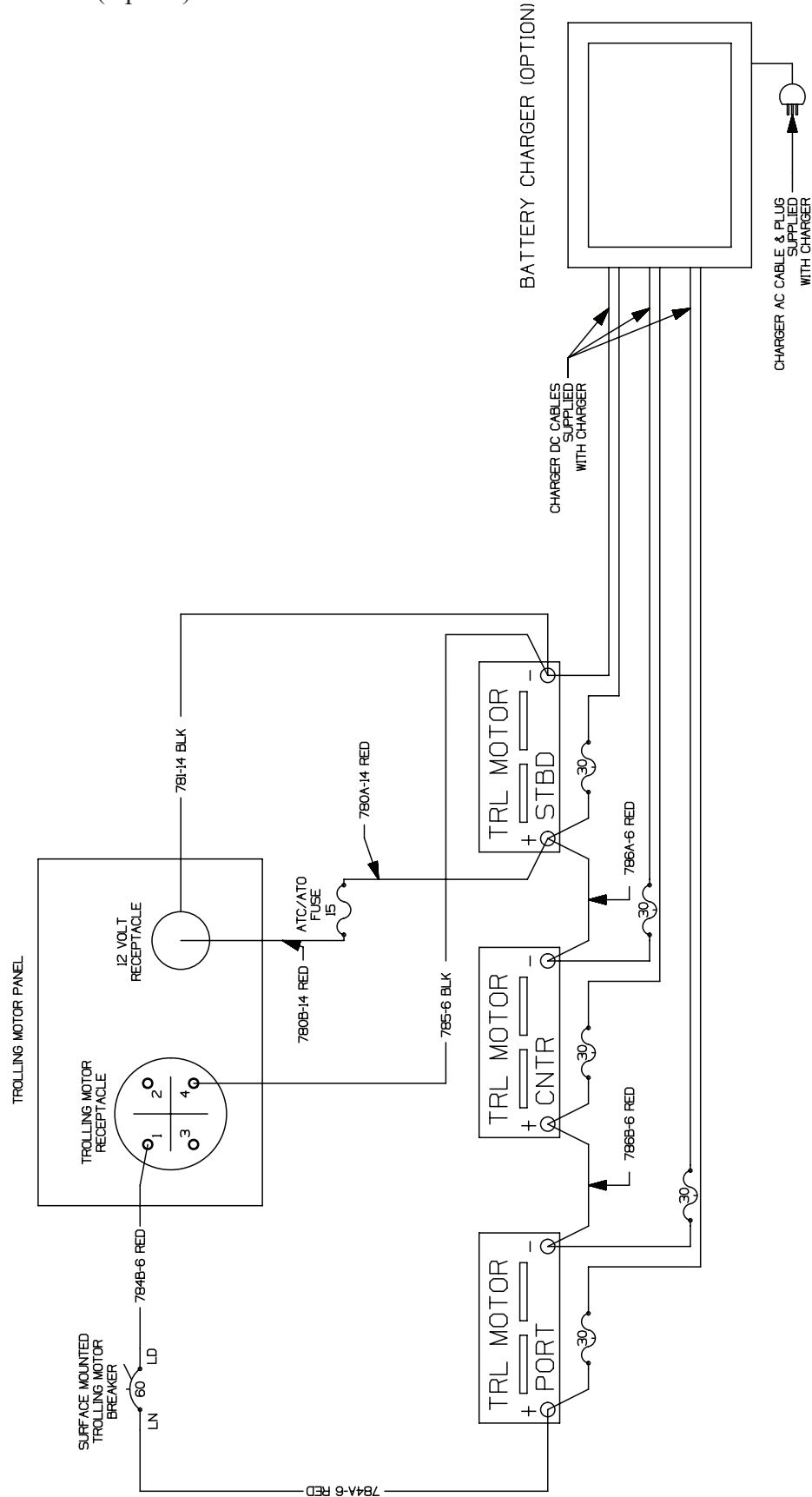

6040-07-401\_8\_H

Helm Panel  
Figure 4.32.1

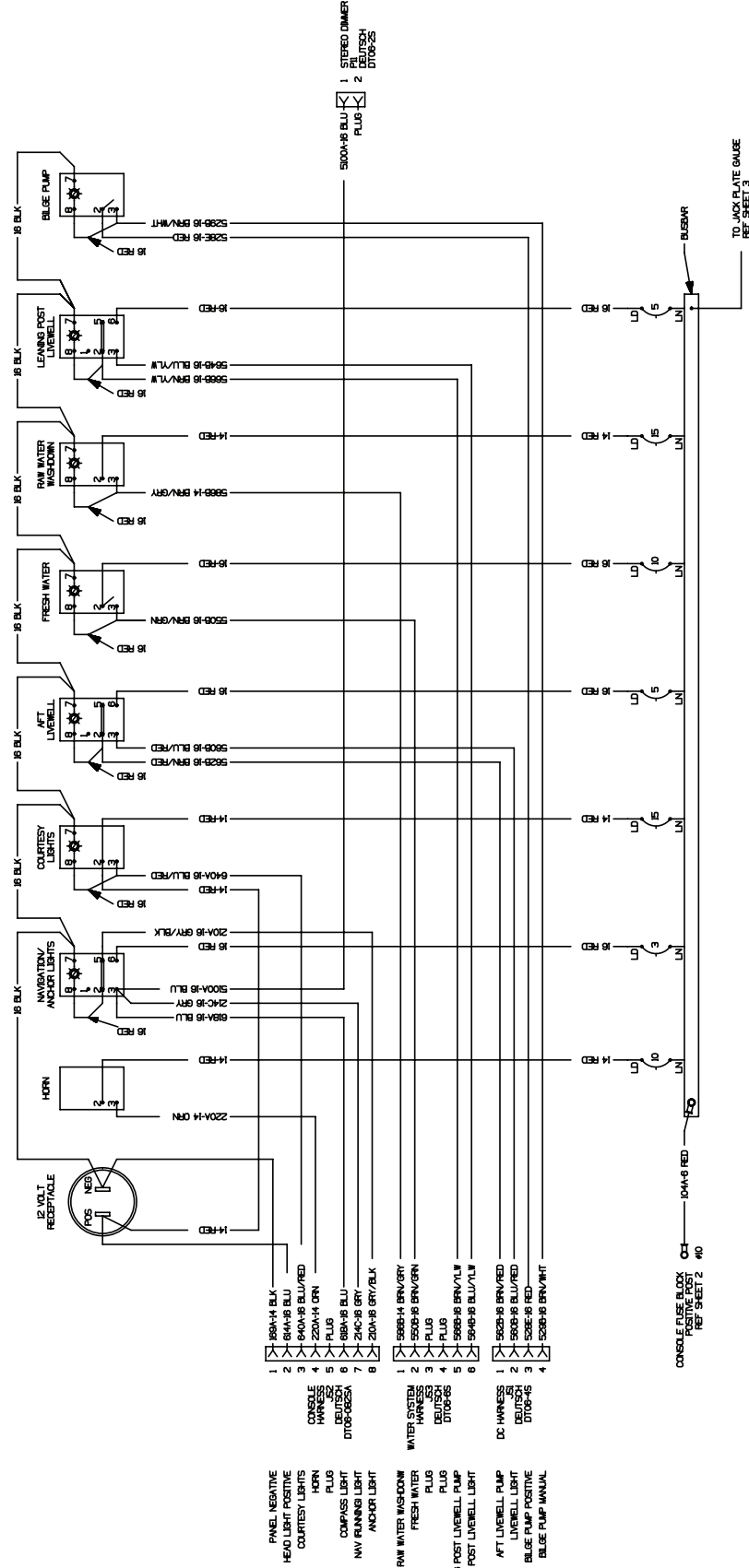

### Routine Care and Maintenance

#### NOTICE

**Refer to the individual manufacturers' manuals for important information regarding service, care and maintenance of your boat, equipment and components. Failure to do so may in some cases void the warranty.**

#### ⚠ DANGER

**When using solvents read all information from the solvent manufacturer regarding safety and handling of the material.**

**Wear proper protective equipment to ensure your personal safety.**

**Only use solvents in a well ventilated area and keep all solvents away from open flame and any other forms of ignition.**

Routine inspection, service and maintenance of your boat. Boat systems and components are vital to assure your safety, as well as prolonging the life of your boat. You should develop regular routines for inspecting and servicing your boat.

#### ⚠ WARNING

**Regularly inspect and test hardware, fittings, windshields, hatches, seams, etc. for proper seal. Reseal and/or readjust/tighten fittings, latches, etc. as needed.**

The interval between necessary service or maintenance is highly variable, depending on the environment in which your boat will be used. For example, corrosion of boat parts and components will occur far more rapidly in a salt water environment than on a boat which is used in fresh water.

This section provides only general guidelines for the care and cleaning of your boat. It is your responsibility to determine whether maintenance and care intervals need to be accelerated due to your boat usage and/or operating environment.

### Hull

Fresh water, saltwater and water temperature can all affect the types of growth that can occur on the boat's hull.

Any growth will affect the boat's performance and overall look. If it has been a while between inspections you might notice algae or slime growth on the hull. This can be cleaned with a coarse towel or soft bristle brush. The growth should be cleaned immediately after the boat has been removed from the water. If the growth is allowed to dry it will be much harder to remove.

Compounding may be necessary to remove more stubborn stains and chalking from the surface of your boat. If compounding is necessary it must be done after a thorough washing and prior to waxing. If the growth is more severe, you may need to enlist the services of a professional hull cleaning company. Contact your Boston Whaler® dealer for recommendations on a compatible rubbing compound or a professional hull cleaning company in your area.

### Aquatic Invasive Species (AIS)

#### NOTICE

**Waxing of the exterior surfaces is recommended to be done at least twice a year to protect the gel coat.**

Aquatic invasive species (AIS) are plants and animals that occur in waters in which they are not native and whose introduction causes or is likely to cause economic or environmental damage or harm to human health. AIS have a negative impact on the waterway, its native species, and recreational and commercial uses of the waterway.

As responsible boaters and citizens, each boat owner should do their part to prevent the spread of these aquatic hitchhikers. In many cases, it is also required by law. Check local regulations for any waterway where you will boat.

After each boating trip, follow these three simple steps before you leave the water access to stop the spread of AIS: Clean, Drain, and Dry. This is the boater's way to help protect the environment from

the damage that AIS can cause.

Rinse, scrub or wash, as appropriate, away from storm drains, ditches, or waterways.

Rinse watercraft, trailer, and equipment with hot water, when possible.

Flush motor according to owner's manual.

### **Drain**

Completely drain all water from the boat and its compartments, including but not limited to the bilge, wells, lockers, ballast tanks or bags, bait containers, engines, and outdrives.

### **Dry**

Allow the boat to completely dry before visiting any other bodies of water.

NOTE: Some localities may require inspection or decontamination before and/or after launching. Check state and local laws and regulations for requirements prior to traveling to go boating.

### **Clean**

Inspect and remove all aquatic plants, animals, mud, and debris from the boat, engine, trailer, anchor, and any watersports equipment.

### **Waxing Gel Coat Surfaces**

Waxing is necessary to provide added protection to the gel coat. Periodic cleaning and waxing ensures your boat will be protected and look good longer.

Do not wax over dirt. Make sure the surface of your boat has received a thorough washing and rinsing and is clean before waxing. If a rubbing compound has been necessary, make sure that any minor scratches or surface pitting is cleaned of compound residue. Use a good quality carnauba wax or a high quality wax designed for marine gel coat. Apply several coats.

### **Hull Maintenance**

If using a pressure washer to clean the hull and deck surfaces of your boat it is important that you use the wide fan nozzle only and move the spray head in a continuous motion. Do not concentrate the high pressure on a small area of the boat surface and never use the fine pinpoint nozzle as the concentrated stream can cause damage to the surface of your boat.

It is also recommended that you refrain from pressure washing the console as high pressure may compromise the integrity of the electronics and gauges as well as other equipment installed on your boat. Also avoid pressure washing any caulk seams.

When staining from build-up does occur, use only cleaning agents that are recommended for marine gel coat for use on those stubborn stains. Never use an abrasive cleaner to wash your boat's hull. Never use an abrasive pad to attempt to remove stubborn stains. Never use strong solvents to clean.

Never apply tape or any other type of adhesives directly to the painted surfaces on your boat.

Use care when covering your boat's painted surfaces as tarps and other such covers can trap dirt and cause chafing. It is best to use a frame of either aluminum or wood to keep the cover up and allow air to circulate.

### **Hull Blistering**

Due to the quality of the materials used in the hulls of Boston Whalers, blistering is rarely ever seen. Blistering is caused by water soluble materials in the hull laminate. The fiberglass and resin structure of your boat is porous. However, intrusion of water into the gel coat will take some time. The effect of osmotic pressure allows water to impregnate below the gel coat and substrate thus forming a blister.

There have been extensive university studies funded by the United States Coast Guard regarding the cause and effect of blistering in the gel coat of fiberglass boats. Fiberglass blisters can form anywhere from near surface layers of the gel coat to very deep into the fiberglass structure. The damage can range from cosmetic to catastrophic. The studies seemed to point toward long term immersion of the hull in warm water as a primary cause of hull blisters. Stress cracks on the hull below the waterline also contribute to the formation of hull blisters.

### **Prevention**

There are a variety of ways to prevent the formation of hull blistering. Epoxy coatings can be applied to the hull, followed by hull painting. An alkyd-urethane-silicone marine paint can also be used to aid in the prevention of hull blisters.

Reducing the amount of time that your boat stays in the water also helps prevent hull blisters from forming. Use of a trailer or boat lift will reduce the likelihood of hull blisters forming. Be sure to use a bunk type lift or trailer for storage of the boat out of water.

Contact a Boston Whaler dealer for more information on the prevention and treatment of hull blisters.

### Bottom Painting

#### **DANGER**

**There are risks and dangers inherent with the use of paints and solvents. Dispose properly of all rags, rollers and trays used for painting. Follow all the precautions and regulations listed by the manufacturer before and after painting.**

#### **NOTICE**

**If blisters are present in the hull, they need to be properly cleaned and dried out before any barrier protection can be applied.**

#### **CAUTION**

**Do not paint over sacrificial anodes. This action renders them useless and lead to deterioration of the underwater metal parts of your boat.**

**Some bottom paints contain metals that can cause corrosion of the outboard engine. Leave a minimum of 3/4" unpainted around all engine parts. Use only a paint specifically designed for aluminum engines as anti-fouling protection.**

If your boat will spend most of its time in the water, painting the bottom of your boat's hull is a good way to slow the formation of hull blisters and to keep bottom growth (fouling) under control. If you will be trailering the boat to and from the water, you might want to forgo the painting.

The following is an abbreviated section on bottom hull painting. A Boston Whaler dealer should have information on properly painting your boat's hull or recommendations on qualified hull painters.

### Bare Hull Painting

Preparation is the key to successful hull painting. Take extra care and time in preparation before proceeding to paint. Begin by scrubbing the surface thoroughly with a stiff brush using an all-purpose marine soap and water to remove loose dirt and contamination. Flush with fresh water to remove all soap residue.

The gelcoat will have to be dewaxed of mold release wax before sanding can begin, otherwise the wax will be dragged into the scratches and will reduce the adhesion properties of the paint.

Remove any mold release wax that may be present using fiberglass surface prep solvent and a scrub pad. Scrub only a few square feet at a time. Flush with fresh water. If the water beads up or separates, continue scrubbing the surface. When the water sheets off, the wax contaminate has been removed.

After the dewaxing is complete, application of a primer coat is recommended. Pay close attention to scratches, nicks and dings in the surface. If necessary, fill any repair areas with a watertight epoxy filler. After filler is cured, sand with 80 grit paper until smooth. Remove the sanding residue using a fiberglass solvent wash. The paint can be applied after sanding and cleaning is complete. Follow the paint manufacturer's recommendations for application.

#### **WARNING**

**Proper ventilation and capture of the dust created by sanding is essential. The dust created by sanding is toxic and should not be inhaled. A proper fitting respirator must be used. Do not use a paper filter mask.**

#### **WARNING**

**Bottom paint is designed to resist algae growth which means it has chemicals embedded in the paint that are harmful if ingested. Take all necessary precautions required before painting or repainting your boat's hull.**

### Bottom Painting a Pre-Painted Hull

If the hull bottom is already painted, you must be sure to test the paint's adhesion to the already painted surface. If the paints are incompatible, the new paint will not adhere to the hull bottom or the paint will "lift" the old paint. Never apply paint without first preparing the old painted surface following the paint manufacturer's recommendations.

Follow the paint manufacturer's recommendation for applying the paint. Humidity and weather will play a role in how and when the paint is applied. Several thin layers are better than one thick layer.

To determine the waterline, you will need to place the boat in water with a full load of fuel and gear. Mark the waterline and measure above the marked line 1" to 3" for placement of the tape line.

Make sure that there is enough paint left to cover areas that were not accessible, (slings, jack stands etc.) and paint accordingly. Follow the paint manufacturer's recommendation for do's and don'ts after the painting is complete.

#### **NOTICE**

**Masking tape is not recommended for the types of paint you will be using.**

#### **NOTICE**

**Painting your boat's hull will adversely affect the boat's speed and performance and may require re-propping if the maximum engine RPMs drop below the engine model/mfg recommended operating range.**

### Rubrails

The rubrail on your boat is constructed of an injected high density PVC vinyl material which laboratory tests have proven to be highly resistant to staining, fading and cracking.

As resilient as this material is, you still need to follow some basic maintenance precautions.

General maintenance requires a thorough cleaning with mild soap and water. Do not use any cleaning agents which contain chemicals.

Although the outer shell is tough and durable, there is a chance that it can be breached. Use care when docking or exposing the rubrail to conditions which may cause damage such as docking against heavily barnacle-encrusted pilings.

Some tears (cleanly sliced) can be repaired with a super glue type product.

Areas which have been torn or are affected by heavy abrasion will require the damaged section to be replaced. Please see your Boston Whaler dealer for this type of repair. Fiberglass and Non-Skid

To protect your deck and non-skid areas from the deteriorating affects of the sun, oxidation, water spots and pollution, use a good quality fiberglass and non-skid deck wax every two to three months.

When applied to your deck and non-skid areas, as recommended by the manufacturer, the wax forms a protective non-slick surface which will keep debris from sticking. Dirt, soot, bird droppings, and even fish blood will rinse right off.

### Fiberglass and Non-Skid

To protect your deck and non-skid areas from the deteriorating affects of the sun, oxidation, water spots and pollution, use a good quality fiberglass and non-skid deck wax every two to three months.

When applied to your deck and non-skid areas, as recommended by the manufacturer, the wax forms a protective non-slick surface which will keep debris from sticking. Dirt, soot, bird droppings, and even fish blood will rinse off.

### Stainless Steel

The cleaner your stainless trim and fittings can be kept, the greater the assurance of optimum corrosion resistance. Without proper care even the best stainless steel will corrode.

Stainless steel is strong and corrosion resistant, but still requires maintenance to keep its appearance. Frequent routine cleaning of your stainless steel with a mild soap and water solution and coating with a good grade cleaning wax will help maintain the finish.

- Wash with mild soap and lukewarm water.
- Dry thoroughly.
- Apply cleaning wax with a soft, dry cloth.
- Allow wax to dry, then polish and buff.

### NOTICE

**Never use abrasive cleaners, detergents or soft scrub type cleaners to wash your boats surfaces.**

**Never use abrasive pads, brushes or sponges to attempt to remove stubborn stains.**

**Never use strong solvents or detergents which contain chlorine.**

**Never use silver cleaners.**

Even the finest cleaning powders can scratch or burnish a mill-rolled surface. On polished finishes, rubbing or wiping should be done in the direction of the polish lines, not across them.

Crevice corrosion, a brownish coloring which occurs where two pieces of stainless hardware meet is caused by impurities in water and air. It can be easily cleaned with a grade marine polish using a sponge, cloth or small bristled brush (for nooks and crannies).

### Teak

The teak features on your boat are constructed of natural wood, are durable in all climates, and require little maintenance. Clean teak surfaces by regularly washing with soap and water using a soft brush or sponge. Do not use a steel brush or steel wool. Do not use a pressure washer. Do not use strong solvents or harsh cleaners on the caulking as they can damage or dissolve the caulk. Bleach can be used to treat darker spots on the wood surface. Use fine grain sandpaper to keep the surface smooth and blemish free. There are several maintenance options for teak:

#### Let-it-be (Recommended)

Left alone with the elements, teak changes to a silver-grey patina. To maintain, occasionally wash with soap and water. A light sanding every few years keeps the surface smooth; always sand with the wood grain.

### Oiling

Apply oil to retain or increase the darkness of the original wood. There are numerous products on the market that provide a variety of different characteristics. Refer to the manufacturer's instructions for proper application.

### Lacquer

A correctly applied lacquer ensures years of low-level maintenance and minimizes the risk of mold. Some lacquers can be applied with various grades of thinner to reduce shine. The wood will likely darken when lacquer is applied. Carefully research product information to ensure it's suitable for both teak and caulking.

REFER TO THE MANUFACTURER'S MANUAL IN YOUR OWNER'S PACKET FOR COMPLETE INSTRUCTIONS AND WARRANTY.

### SEATS

Always wash metallic parts with soap and water and rinse thoroughly with fresh water. Once dry, apply a light coating of lubricant to protect moving parts.

Check for loose or damaged hardware and tighten or replace as necessary.

### Aluminum

Preventative maintenance is essential to life of the metals on your boat. The presence of salt particles and moisture is the major cause of white spots, pitting and corrosion.

The use of harsh chemicals can also cause deterioration. Manufacturers and applicators of protective coatings will not warrant protective coatings on metals in the marine environment. Proper owner maintenance is required to reduce deterioration which will result in most cases by failure to wash down and wipe dry after each use and/or the use of abrasive, acidic or other improper cleaners.

Wash completely using a soft cloth and mild detergent to remove salt particles. Hosing alone will not dislodge all particles. Do not allow soap to dry as it may cause stains on coated surfaces. Make sure to wash and dry the full circumference of aluminum parts.



Apply an aluminum protectant at least twice each year, more frequently as conditions warrant. Neglect will cause pitting of the surface which cannot be reversed.

Inspect and repair or replace all damaged nylon bushings, washers or other hardware designed to prevent contact with dissimilar metals.

Whenever electrical or electronic changes are made to the boat, a qualified marine technician should check aluminum parts for stray currents. Make sure all electronic equipment is properly grounded with adequate sized wire.

### Standard Vinyl Cushions

Saltwater, salt residue, dirt and ultra-violet rays will take their toll on vinyl products causing them to lose their luster and texture. To clean standard cushions:

- Remove ordinary dirt and smudges with a mild soap and water solution. Dry with a soft, lint-free cloth or towel.
- More difficult stains can be cleaned using rubbing alcohol. Rinse cleaned area with fresh water and dry with a clean, soft, cloth or towel.
- Seemingly permanent stains like ballpoint ink can be cleaned with active solvents such as nail polish remover when applied with a soft cloth or damp sponge and rubbed. Rinse cleaned area with fresh water and dry with a clean, soft, cloth or towel.

### CAUTION

**Wear rubber gloves when using any solvents. Use caution when cleaning around buttons, stitching, and wooden or decorative trim as solvents could seriously damage such areas.**

REFER TO THE OWNER'S PACKET FOR COMPLETE INSTRUCTIONS AND WARRANTY INFORMATION.

### Cool Technology Vinyl Cushions (Option)

If this vessel is equipped with cool technology vinyl seat cushions, clean this material per the manufacturer's instructions at <https://spradling.group/en-sm>

### Water Exposure

Boat cushions are not waterproof and will absorb and hold water. Do not leave the cushions in standing water or exposed to heavy, prolonged rain. If cushions become waterlogged, remove the foam from the cushion, press out as much water as possible from the foam and allow to air dry. To prevent mildew, keep the vinyl dry and make sure that moisture does not accumulate between the cushions.

### Instrumentation Cleaning

When gauges are exposed to a saltwater environment, salt crystals may form on the bezel and plastic covers. Remove the salt crystals with a soft damp cloth. Clean with a mild household detergent or plastic cleaner.

Never use abrasives or rough, dirty cloths to clean plastic parts. A mild household detergent or plastic cleaner should be used. Wipe clean with a damp chamois.

FOR MORE INFORMATION, CONTACT MERCURY MARINE CUSTOMER SERVICE AT 920-929-5040.

### Canvas

## NOTICE

**Do not use detergents, bleach or solvents to clean your canvas.**

To keep your canvas and metal parts in good working condition and in good appearance, you will need to keep them clean.

The fabric should be cleaned regularly before substances such as dirt, pollen, etc. are allowed to accumulate on and become embedded in the fabric. The canvas can be cleaned without being removed from the installation.

Chafing, fiber wear from dirt and grit and deterioration from ultraviolet light can cause your canvas to degrade over time.

### Maintaining Appearance

After each use, especially if used in salt water areas, rinse the canvas completely with fresh cold water. To maintain canvas:

- Brush off any loose dirt, pollen, etc.
- Hose down with fresh cold water and clean with a mild solution of a natural soap in lukewarm water (maximum 100°F / 38°C).
- Allow the canvas to soak. Do not allow the soap to dry.
- Rinse thoroughly with fresh water.
- Let the canvas dry completely. Do not store any of the canvas pieces while wet.

The effects of ultraviolet light can sometimes be reduced by chemical treatment of canvas items.

Consult your Boston Whaler dealer or check your canvas manufacturer's manual before using any chemical treatments on your canvas.

### Stubborn Canvas Stains

Soak fabric for approximately twenty minutes in a mild solution consisting of no more than 1/2 cup (4 oz.) of bleach and 1/4 cup (2 oz.) of natural soap per gallon of lukewarm water (not to exceed 100° F / 38° C).

Rinse thoroughly in cold water several times. Allow the fabric to air dry completely.

### NOTICE

**Failure to remove all of the soap solution can cause deterioration of seams and prevent fabric from proper retreating.**

Retreat the fabric using an air curing product such as 303 High Tech Fabric Guard to ensure water and stain repellency.

All canvas should be stored flat or rolled in a clean, dry space.

### Canvas Zippers

### NOTICE

**Do not use petroleum based products, such as petroleum jelly, on the zippers or fasteners.**

Lubricate zippers and fasteners periodically with a

clear silicone spray. In the absence of silicone spray, a wax candle can be used to lubricate the zipper track.

Replace any missing fasteners or any fasteners showing signs of corrosion.

### Acrylic Windscreen

- Rinse windscreen thoroughly with clear water to remove any dust, dirt particles, salt water or environmental agents before applying cleaning products.

Use your bare hand, with plenty of water, to feel and dislodge any stuck-on dirt or foreign particles.

This should be done frequently to avoid build up of salt water, dirt and other environmental contaminants.

- Using a soft non-abrasive cloth, wash windows inside and out with a mild soap (Woolite, Joy, Palmolive, etc.) and water solution. Rinse completely with cool water.
- Do not use detergents.
- Blot dry with a soft cloth or chamois to prevent water spots.

The use of a polycarbonate protective cleaner/restorer is recommended to keep your acrylic scratch resistant, clean and minimize the deteriorating effects of sunlight.

### NOTICE

**Never use a dry cloth or duster or glass cleaning solutions on acrylic.**

**Do not use solvents such as acetone, silicone spray, benzine, carbon tetrachloride, fire extinguisher fluid, dry cleaning fluid, lacquer thinner, glass cleaning solution or harsh detergents on acrylic.**

**The above substances will attack the surface of the acrylic.**

### Powder Coating Touch-Up

If it is necessary to apply touch-up paint on areas of the finish that have been scratched or damaged the powder material supplier should be contacted for their recommendation of the proper touch-up material to use.

Single component acrylic enamel (spray enamel) touch-up paint is commonly used for repair of minor damage in the powder coated finish. In some cases a two-component catalyzed paint system may be required to achieve the desired repair. In all cases, perform a color and adhesion test in an inconspicuous area of the finish to assure compatibility before applying the paint to the damaged area.

### Touch-up Procedure

- Clean surface of dirt, oil, grease, etc.
- Sand lightly with 400 grit wet/dry abrasive paper.
- Remove sanding dust with a lint-free cloth dampened with mineral spirits.
- Temperature of surface and paint must be at room temperature (between 70 to 90 degrees is ideal).
- Apply paint to minor scratches by spraying a small amount of paint into the container's cap. Using a small brush, carefully apply the paint sparingly to the properly prepared surface. Do not apply heavy coat all at once. Apply several light coats allowing the paint to dry until tacky between each coat.

### NOTICE

**For the best results, use Orbit Industries touch-up paint, RAL 9010 Pure White.**

**Orbit Industries: 800-448-3885**

### NOTICE

**The visual, mechanical, chemical as well as corrosion protective and weather resistance properties of repaired areas ARE NOT equal to those of the original powder coating and are not suitable for long term performance.**

### NOTICE

**If painting over exposed or bare metal, a chemical pretreatment process and/or primer sealer is recommended.**

**Follow manufacturer's recommendations.**

### NOTICE

**It is highly recommended that you do not penetrate the powder coating on your boat by securing equipment or other objects onto the coated surface. If necessary, contact the manufacturer for repair recommendations.**

FOR MORE INFORMATION, CONTACT APEX POWDER COATING, INC CUSTOMER SERVICE AT 864-288-2739.

### Long Term Storage and Winterization

Long periods of storage, winter lay-up and/or non-use, common to boats, create unique problems. When preparing to store a boat for extended periods of two months or more it is best to make sure that the boat and its systems are properly conditioned for such extended periods of non-usage.

The guidelines presented on the following pages give basic instructions on winterizing your boat and boat systems. If inexperienced with the process of winterization it is best to hire the services of a professional.

In addition, always consult the owner's manuals of the various systems and equipment on your boat for the manufacturer's recommendations on winterizing and long term storage.

### Engine



#### CAUTION

**Never start or run your outboard (even momentarily) without having water circulating through the cooling water intake holes in the gear case. This will prevent damage to the water pump (running dry) or overheating of the engine.**

Protecting your engine's vital moving parts from corrosion and rust caused by freezing of trapped water or excessive condensation due to climatic changes is very important. Freezing water in the engine can cause extensive damage to the internal moving parts. Internal engine parts can also be affected by rust due to lack of proper lubrication. To protect your engine:

- Replace engine oil and filter, running the engine to drain out as much old oil as possible.
- Flush engine with fresh water using flush mufflers or similar device attached to raw water pickup.
- Let all water drain from engine.
- Fog engine while running. Spray until it stalls.
- Run fuel which has been treated with conditioner and stabilizer through engine.
- Replace lower unit gear oil. Check for moisture in old oil, a sign of deteriorating seals.
- Remove prop and grease shaft and threads.
- Treat all grease fittings with recommended lubricant.
- Lightly lubricate exterior of engine or polish with a good wax.
- Check engine mount bolts; ensure bolts are torqued to 55 ft/lbs.
- Follow all recommendations in engine manufacturer's operation manual.

### Fuel System

Tank(s), hoses, and fuel pumps should be treated to help prevent the formation of varnish and gum.

Temperature extremes will cause condensation to accumulate in an empty or partially filled fuel tank leading to fuel contamination and/or premature wear of your system.

Fill the tank completely (100 percent) full and add fuel stabilizer and conditioner, following the manufacturer's recommendations, to provide fuel stability and corrosion protection.

#### NOTICE

**Pay particular attention to the information provided in ethanol-blended fuel in Chapter 3 of this manual.**

### After Long Term Storage

At least annually, inspect your fuel system for leaks. You should check the fuel tank area below the floor for liquid fuel, or a strong odor of gasoline before each outing, but at least once a year you should open each access port to any of the fuel system components to inspect them for leakage. If any leakage or seeping of fuel around any fuel system fitting is found, or there is a strong odor of gasoline, Do not turn on or off any electrical appliances or attempt to start your boat; open all hatches to allow the compartment to ventilate, and call a qualified service/repair person for inspection and repair of the leak before using your boat.

### Electrical System

- Check all connections and tighten if necessary.
- Apply an anti-corrosion spray on all connections.

### Batteries

#### NOTICE

**Follow the manufacturer's recommendations for long term storage of your battery(s).**

Engine and house electrical systems on our boats have become increasingly more complex and are reliant on a good source of power. The house source of power typically comes from a battery bank comprised of two or three batteries in parallel. The charging source for the batteries while away from the dock is the engine; or if equipped a generator and the generator is on, battery chargers. As the engine/generator are providing a charge output to the house bank through the automatic charging relays (ACRs), keep in mind the following battery recommendations

#### Mixing Fresh, Used and Dead Batteries

The fresh battery will deliver current into a dead battery which has high resistance. This results in excessive heat in the used/dead battery, which can cause further damage, leakage, or rupture. A used battery will drain energy from the new one, reducing the total amount of battery power available.

#### Mixing Battery Types

Different battery types are designed for different purposes. Mixing an AGM battery with a lead acid battery will not improve performance. This results in reduced performance, may damage your devices, or cause battery leakage or rupture.

#### Mixing Battery Brands

Different battery brands may not have the same specifications like marine cranking amps (MCA) or cold cranking amps (CCA). This results in excessive heat, which may then cause damage, leakage or rupture in one of the batteries. We recommend using the same type of batteries throughout a boat.

#### Deck

Clean the deck with soap, hot water and a stiff brush to clean up any oil spills.

#### Drainage

It is important to raise the bow of the boat enough to allow for proper drainage of water from the deck and bilge area. Make sure all the drainage fittings

are clear and free of debris and plugs are removed. Store the engine in an upright position to promote adequate drainage of water.

#### Cover

When covering your boat it is best to use a frame of either aluminum or wood to keep the cover up. This allows air to circulate and discourages water from pooling on the cover.

#### NOTICE

**Do not use a bimini top in lieu of a cover. Damage and aging will occur while providing no protection for your boat.**

Vents along the entire length of the cover allows condensation to escape. Placing a series of foam pads between the hull and cover also aids in circulation and reduce condensation. To help keep your boat dry and mildew free, consider placing commercial odor and moisture absorbing products under the cover.

#### Trailer Storage

Repeatedly immersing the trailer in water during boat launching can cause a variety of problems. Water seeping into the wheel hubs will cause the grease to emulsify and can prematurely corrode the bearings. Check with the trailer manufacturer for scheduled maintenance of your trailer.

#### Environment

Antifreeze and other winterizing fluids can be toxic to aquatic life and cause harmful effects to plant life. Improper disposal of, or spillage of antifreeze and/or any winterization fluids can cause environmental problems when allowed to empty into waterways or on the ground. Furthermore, it is illegal, punishable at minimum by fines. Used antifreeze or any winterization fluids, should not be disposed of into sanitary sewers or publicly owned treatment plants. Persons who have any questions regarding recycling antifreeze or other toxic fluids should write or call their state's EPA office.

## Chapter 5 • Care and Maintenance

### Reinforcement Locations

This vessel has been manufactured with reinforcement in various locations throughout the deck. In the event you wish to add equipment that requires penetrating the deck with fasteners, Figure 5.11.1 illustrates the size and type of reinforcement materials. (see Figure 5.12.1) for reinforcement locations. The table below provides a description of the material and recommended fasteners to secure added equipment.

Reinforcement	Construction	Equipment Weight	Fastener Type*
Plywood	Standard boat building material	Light	Self-tapping screws
Trevira	Thick spun bound polyester fabric	Light	Sheet Metal screws
Aquaplas	High density plastic	Medium	Self-tapping screws
Phenolic	Fiberglass reinforced composite board	Heavy	Drill and tap

\* Drill and countersink a pilot hole to prevent damage to the gelcoat surface.

Reinforcement Dimensions  
Figure 5.11.1

1	1/2" phenolic 5.875" × 10.875"	23	3/8" phenolic 8.5" × 10"
2	1/2" phenolic 5.5" × 10.5"	24	3/8" phenolic 1.5" × 2"
3	1/2" phenolic 8" × 8"	25	1/2" plywood 3.375" × 10.75"
4	3/8" phenolic 5.5" × 9.5"	26	3/8" phenolic 2" × 6.5"
5	1/2" phenolic 3.5" × 14"	27	1/2" plywood 7.5" × 10"
6	3/8" phenolic 4.5" × 9.375"	28	1/2" plywood 7" × 7"
7	3/8" phenolic 4.875" × 12.75"	29	1/2" plywood 6.5" × 7.5"
8	3/8" phenolic 5" × 8"	30	1/2" plywood 5" × 7"
9	1/2" phenolic 2.5" × 8"	31	1/2" plywood 5" × 8"
10	1/2" phenolic 4.25" × 6"	32	1/2" plywood 8" × 10"
11	3/8" phenolic 3.75" × 9.5"	33	1/2" plywood 6" × 7"
12	1/2" phenolic 2.5" × 6"	34	1/2" plywood 6" × 8"
13	1/2" phenolic 2.5" × 6.5"	35	1/2" plywood 4" × 7"
14	3/8" phenolic 4" × 4"	36	1/2" plywood 10" × 10"
15	3/8" phenolic 6.5" × 6.5"	37	1/2" plywood 12.75" × 13.5"
16	1/2" phenolic 2" × 4"	38	3/8" phenolic 4" × 9"
17	1/2" phenolic 2.5" × 4.5"	39	3/8" phenolic 1.25" × 6"
18	3/8" phenolic 3.5" × 3.5"	40	1/2" plywood 6.75" × 11"
19	3/8" phenolic 2" × 5"	41	1/2" plywood 6.75" × 11"
20	1/4" plywood 1.25" × 7.5"	42	1/2" phenolic 14.75" × 15"
21	1/4" plywood 1.25" × 10.75"	43	1/2" phenolic 7.5" × 21"
22	3/8" phenolic 5" × 5.75"		

Reinforcement Locations  
Figure 5.12.1

**! CAUTION**  
Do not attempt to secure equipment in any location other than those that are illustrated.

